



(11) **EP 2 146 151 A1**

(12) **EUROPEAN PATENT APPLICATION**  
published in accordance with Art. 153(4) EPC

(43) Date of publication:  
**20.01.2010 Bulletin 2010/03**

(51) Int Cl.:  
**F24F 5/00 (2006.01)**

(21) Application number: **08738453.3**

(86) International application number:  
**PCT/JP2008/000841**

(22) Date of filing: **01.04.2008**

(87) International publication number:  
**WO 2008/126390 (23.10.2008 Gazette 2008/43)**

(84) Designated Contracting States:  
**AT BE BG CH CY CZ DE DK EE ES FI FR GB GR HR HU IE IS IT LI LT LU LV MC MT NL NO PL PT RO SE SI SK TR**  
Designated Extension States:  
**AL BA MK RS**

(72) Inventors:  
• **SUGIMOTO, Tomohiro**  
**Chuo-ku, Osaka 540-6207 (JP)**  
• **OGAWA, Masanori**  
**Chuo-ku, Osaka 540-6207 (JP)**

(30) Priority: **09.04.2007 JP 2007101528**

(74) Representative: **Fritsche, Rainer**  
**Eisenführ, Speiser & Partner**  
**Postfach 31 02 60**  
**80102 München (DE)**

(71) Applicant: **Panasonic Corporation**  
**Kadoma-shi**  
**Osaka 571-8501 (JP)**

(54) **ELECTRICAL COMPONENT BOX FOR AIR CONDITIONING APPARATUS AND AIR CONDITIONING APPARATUS PROVIDED WITH THE ELECTRICAL COMPONENT BOX**

(57) An electrical component box for an air conditioner that includes a compressor and a cooling fan separated from each other by a partition plate. The electrical component box includes a first control substrate having an exothermic element mounted thereon, a first substrate holder disposed above the partition plate to hold the first control substrate, a second control substrate having a non-exothermic element and disposed generally perpendicular to the first control substrate or generally horizontally, a second substrate holder for holding the second control substrate, and a set of radiating fins mounted on the first control substrate so as to protrude therefrom on a fan side with respect to the partition plate.

Fig. 1

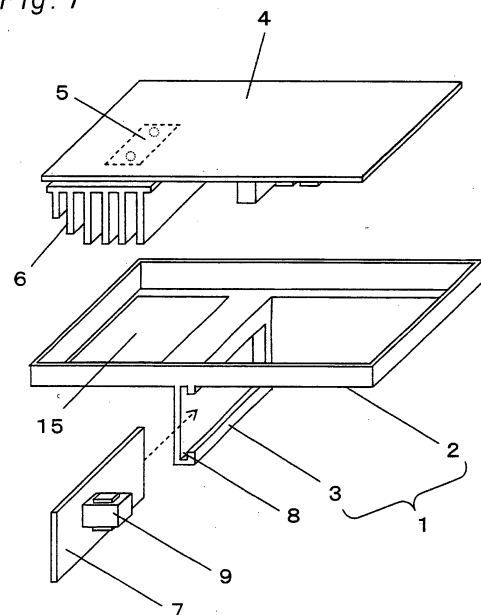

**EP 2 146 151 A1**

## Description

### Technical Field

**[0001]** The present invention relates to an air conditioner and, more particularly, to an electrical component box for the air conditioner.

### Background Art

**[0002]** A conventional air conditioner is used with an electrical component box having a control substrate, on which a plurality of electrical components are mounted, to control the air conditioner (see, for example, Patent Document 1).

**[0003]** Fig. 6 is an exploded perspective view depicting an example of a construction of an electrical component box as disclosed in Patent Document 1. As shown in Fig. 6, the electrical component box 21 for an air conditioner includes substrate holders 22, 23 each having electrical components such as, for example, an inverter and the like, a printed wiring board 27 mounted horizontally on the substrate holder 22 so as to cover an upper surface thereof, and a printed wiring board 30 mounted vertically on the substrate holder 23 so as to cover a rear surface thereof. The printed wiring board 27 includes a set of radiating fins 26 exposed on one side of the substrate holder 22 and having exothermic electronic elements 24, 25 mounted thereon that are cooled by a cooling fan, while the printed wiring board 30 includes a set of radiating fins 29 exposed on the rear surface side of the substrate holder 23 and having an exothermic electronic element 28 mounted thereon that is cooled by the cooling fan.

**[0004]** The substrate holders 22, 23 accommodate a reactor 31 therein such that an upper surface and a rear surface of the reactor 31 may be covered with the printed wiring board 27 and the printed wiring board 30, respectively.

**[0005]** An inverter control device for driving a motor has been also proposed to control an air conditioner (see, for example, Patent Document 2).

**[0006]** Fig. 7 is a block diagram of such an inverter control device. As shown in Fig. 7, a main circuit includes an AC power source 51, a diode bridge 52 for converting an AC power to a DC power, a reactor 61 having a small capacity less than 2mH, a capacitor 62 having a small capacity less than 100 $\mu$ F, an inverter 53 for converting a DC power to an AC power, and a motor 54 driven with the AC power converted by the inverter 53. On the other hand, a control circuit includes a motor voltage command preparing means 64 for preparing a voltage command value for each phase of the motor 54 depending on a speed command  $\omega^*$  for the motor 54 given from outside, a PN voltage detecting means 65 for detecting a DC voltage value applied to the inverter 53, and a PN voltage predicting means 69 for calculating a predicted DC voltage value at a timing when the inverter 53 actually outputs

a voltage. The control circuit also includes a PN voltage correcting means 66 for first deriving a PN voltage correction factor by dividing a previously set DC voltage reference value of the inverter 53 by the predicted DC voltage value calculated by the PN voltage predicting means 69, and for subsequently setting, when the detected DC voltage value is less than zero, a previously set maximum value of the PN voltage correction factor to the PN voltage correction factor. The control circuit further includes a motor voltage command correcting means 67 for correcting the voltage command value for each phase by multiplying the voltage command value for each phase, prepared by the motor voltage command preparing means 64, by the PN voltage correction factor outputted from the PN voltage correcting means 66, and a PWM control means 68 for producing a PWM signal for the inverter 53 so that a motor voltage command correction value obtained by the motor voltage command correcting means 67 may be applied to the motor 54.

**[0007]** By this construction, the use of the small-capacity capacitor and the small-capacity reactor realizes a small-sized, lightweight, and inexpensive inverter control device for drive of the motor, with which even if the motor drive becomes difficult or impossible due to considerable changes in inverter DC voltage, the inverter is operated to make the voltage applied to the motor substantially constant, thereby making it possible to ensure the motor drive.

- Patent Document 1: Japanese Laid-Open Patent Publication No. 11-63574
- Patent Document 2: Japanese Laid-Open Patent Publication No. 2005-304248

### Disclosure of the Invention

#### Problems to be Solved by the Invention

**[0008]** In the case of the conventional electrical component box for the air conditioner as described above, however, because the exothermic elements are separately mounted on the first printed wiring board and the second printed wiring board, two sets of radiating fins are required. Also, because the reactor is independently arranged, and the first printed wiring board and the second printed wiring board are arranged so as to cover the reactor, miniaturization of the whole electrical component box may be difficult.

**[0009]** The present invention has been developed to overcome the above-described disadvantages.

**[0010]** It is accordingly an objective of the present invention to provide an electrical component box that can be reduced in size.

#### Means to Solve the Problems

**[0011]** In accomplishing the above objective, the electrical component box for an air conditioner according to

the present invention includes a first control substrate having an exothermic element mounted thereon, a first substrate holder disposed above a partition plate, which partitions a compressor and a cooling fan from each other, to hold the first control substrate, a second control substrate having a non-exothermic element mounted thereon, a second substrate holder disposed generally perpendicular to the first substrate holder or generally horizontally on a compressor side with respect to the partition plate to hold the second control substrate, and a set of radiating fins mounted on the first control substrate so as to protrude therefrom on a fan side with respect to the partition plate.

#### Effects of the Invention

**[0012]** According to the present invention, not only can the size of the electrical component box for an air compressor be reduced, but the size of the air conditioner can also be reduced.

#### Brief Description of the Drawings

##### **[0013]**

Fig. 1. is an exploded perspective view depicting a construction of an electrical component box for an air conditioner according to a first embodiment of the present invention.

Fig. 2 is a front view of an outdoor unit provided with the electrical component box of Fig. 1.

Fig. 3 is an exploded perspective view depicting a construction of an electrical component box for an air conditioner according to a second embodiment of the present invention.

Fig. 4 is a front view of an outdoor unit provided with the electrical component box of Fig. 3.

Fig. 5 is a front view of an outdoor unit provided with an electrical component box according to a third embodiment of the present invention.

Fig. 6 is an exploded perspective view depicting a construction of a conventional electrical component box for an air conditioner.

Fig. 7 is a block diagram of a conventional inverter control device for drive of a motor.

#### Explanation of Reference Numerals

##### **[0014]**

1	Electrical component box
2	Substrate holder
3	Substrate holder
4	Control substrate
5	Exothermic component
6	Radiating fins
7	Control substrate
8	Slot

9	Reactor
10	Outdoor unit
11	Compressor
12	Cooling fan
5 13	Partition plate
14	Fan motor
15	Opening
16	Side surface of outdoor unit
17	Electrical component box
10 18	Fixing plate
101	Electrical component box
102	Substrate holder
103	Substrate holder

#### 15 Best Mode for Carrying out the Invention

**[0015]** A first invention includes a first control substrate having an exothermic element mounted thereon, a first substrate holder disposed above a partition plate, which partitions a compressor and a cooling fan from each other, to hold the first control substrate, a second control substrate having a non-exothermic element mounted thereon, a second substrate holder disposed generally perpendicular to the first substrate holder or generally horizontally on a compressor side with respect to the partition plate to hold the second control substrate, and a set of radiating fins mounted on the first control substrate so as to protrude therefrom on a fan side with respect to the partition plate. This construction can reduce the size of an electrical component box.

**[0016]** In a second invention, the second substrate holder provided in the first invention has a slot defined therein into which the second control substrate is inserted. By this construction, not only can the size of the electrical component box be reduced, but the second control substrate can also be easily attached.

**[0017]** In the first or second invention, a third invention further includes a reactor mounted on the second control substrate. This construction can reduce the size of the electrical component box.

**[0018]** A fourth invention is directed to an air conditioner including the electrical component box according to any one of the first to third inventions. This invention can reduce the size of the air conditioner. Embodiment 1.

**[0019]** Fig. 1 is an exploded perspective view depicting a construction of an electrical component box for an air conditioner according to a first embodiment of the present invention.

**[0020]** As shown in Fig. 1, the electrical component box 1 is integrally formed of a resinous material and includes a substrate holder 2 constituting a first substrate holder, and a substrate holder 3 constituting a second substrate holder and extending in a direction generally perpendicular to the substrate holder 2 (substantially vertically downwardly).

**[0021]** A control substrate 4 constituting a first control substrate includes a plurality of electrical components mounted thereon and including an exothermic element

5, and is mounted on the substrate holder 2. A set of radiating fins 6 are mounted on the control substrate 4 to radiate heat emitted from the exothermic element 5. It is noted here that the exothermic element is an element that gives rise to a considerable power loss and heat generation incidental thereto and, hence, requires radiating fins for cooling. Exothermic elements include a diode for use in a rectifying circuit that constitutes an inverter control device for a motor required to drive an air conditioner to convert an AC power to a DC power, as disclosed in Patent Document 2, an IGBT for use in an inverter circuit for converting a DC power to an AC power, and the like.

**[0022]** A control substrate 7 constituting a second control substrate includes a reactor 9 and a plurality of electrical elements mounted thereon and including no exothermic elements (electrical elements not producing much heat and requiring no radiating fins, or non-exothermic elements). This control substrate 7 is inserted into a slot 8 defined in the substrate holder 3. Because of this, the control substrate 4 and the control substrate 7 are arranged generally perpendicular to each other. By performing the control as proposed in Patent Document 2 in which an inverter control device for drive of a motor is disclosed, even the use of a small-capacity reactor can ensure the motor drive, i.e., the operation of the air conditioner. Accordingly, the reactor can be reduced in size and weight and, hence, the illustrated reactor 9 can be readily attached to the control substrate 7.

**[0023]** Fig. 2 is a front view of an outdoor unit 10 of an air conditioner provided with the electrical component box according to this embodiment. As shown in Fig. 2, the outdoor unit 10 accommodates a compressor 11 and a cooling fan 12 therein, and the compressor 11 and the cooling fan 12 are separated by a vertically extending partition plate 13. The electrical component box 1 is disposed above the partition plate 13 within the outdoor unit 10.

**[0024]** The control substrate 7 is disposed in a compressor side compartment with respect to the partition plate 13 so as to extend parallel to the partition plate 13.

**[0025]** The radiating fins 6 protrude downwardly through an opening 15 defined in the substrate holder 2 within a fan side compartment with respect to the partition plate 13. Accordingly, radiation from the radiating fins 6 is promoted by the cooling fan 12 driven by a fan motor 14.

**[0026]** It is noted here that the control substrate 4, the control substrate 7, the compressor 11, and the fan motor 14 are connected to one another by a wire harness or the like.

**[0027]** In the electrical component box 1 structured as described above, the control substrate 4 and the control substrate 7 are disposed generally perpendicular to each other, and the reactor 9 is mounted on the control substrate 7. This construction can reduce the size of the whole electrical component box, thereby making it possible to locate the electrical component box 1 at a position not interfering with the compressor 11 or the cooling fan

12.

**[0028]** Also, because the electrical component box 1 can be efficiently accommodated within a space delimited by the compressor 11, the partition plate 13, and a rear surface (not shown) and a side surface 16 of the outdoor unit 10, the outdoor unit 10 can be reduced in size.

**[0029]** Further, because the control substrate 7 is attached to the electrical component box 1 by inserting the former into the slot 8 in the latter, attachment of the control substrate 7 is easy. Embodiment 2.

**[0030]** Fig. 3 is an exploded perspective view depicting a construction of an electrical component box for an air conditioner according to a second embodiment of the present invention. In this embodiment and the first embodiment, like parts are designated by like reference numerals, and explanation thereof is omitted.

**[0031]** As shown in Fig. 3, the electrical component box 101 is integrally formed of a resinous material and includes a substrate holder 102 constituting a first substrate holder, and a substrate holder 103 constituting a second substrate holder and extending in a direction generally parallel to the substrate holder 102.

**[0032]** A control substrate 104 constituting a first control substrate includes a plurality of electrical components mounted thereon and including an exothermic element 5, and is mounted on the substrate holder 102. A set of radiating fins 6 are mounted on the control substrate 104 to radiate heat emitted from the exothermic element 5.

**[0033]** A control substrate 107 constituting a second control substrate includes a reactor 9 and a plurality of electrical elements mounted thereon and including no exothermic elements. This control substrate 107 is inserted into a slot 108 defined in the substrate holder 103. Because of this, the control substrate 104 and the control substrate 107 are both arranged generally horizontally. As described above, because the reactor 9 can be reduced in size and weight, it can be readily attached to the control substrate 107.

**[0034]** It is noted here that high lead elements such as, for example, capacitors, reactors, and the like are mounted on the control substrate 104 and the control substrate 107.

**[0035]** The control substrate 104 and the control substrate 107 are both attached to the electrical component box 101 such that an element surface of the former on which the lead elements are mounted and an element surface of the latter on which the lead elements are mounted are opposed to each other and, hence, all the lead elements mounted on the two control substrates 104, 107 are positioned so as not to be in contact with each other.

**[0036]** By way of example, in applications where a single-sided substrate is used for the control substrate 104, and surface-mount elements such as a microcomputer 117 and the like are mounted on the control substrate 104, a space is created on a surface (lead element surface) opposite to the surface on which the surface-mount

elements are mounted. By designing the control substrate 107 such that the high elements mounted thereon and including the reactor 9 are positioned in such a space, the control substrates can be efficiently accommodated in the electrical component box 101.

**[0037]** Fig. 4 is a front view of an outdoor unit 10 of an air conditioner provided with the electrical component box 101 according to this embodiment. As shown in Fig. 4, the outdoor unit 10 accommodates a compressor 11 and a cooling fan 12 therein, and the compressor 11 and the cooling fan 12 are separated by a vertically extending partition plate 13. The electrical component box 101 is disposed above the partition plate 13 within the outdoor unit 10.

**[0038]** The control substrate 107 is disposed in a compressor side compartment with respect to the partition plate 13. The radiating fins 6 protrude downwardly through an opening 15 defined in the substrate holder 102 within a fan side compartment with respect to the partition plate 13. Accordingly, radiation from the radiating fins 6 is promoted by the cooling fan 12 driven by a fan motor 14.

**[0039]** It is noted here that the control substrate 104, the control substrate 107, the compressor 11, and the fan motor 14 are connected to one another by a wire harness or the like.

**[0040]** In the electrical component box 101 structured as described above, the control substrate 104 and the control substrate 107 are disposed generally horizontally, and the reactor 9 is mounted on the control substrate 107. This construction can reduce the size of the whole electrical component box, thereby making it possible to locate the electrical component box 101 at a position not interfering with the compressor 11 or the cooling fan 12.

**[0041]** Also, because the electrical component box 101 can be efficiently accommodated within a space delimited by the compressor 11, the partition plate 13, and a rear surface (not shown) and a side surface 16 of the outdoor unit 10, the size of the outdoor unit 10 can be reduced.

**[0042]** Further, because the control substrate 107 is attached to the electrical component box by inserting the former into the slot 108 in the latter, attachment of the control substrate 107 is easy. Embodiment 3.

**[0043]** An electrical component box for an air conditioner according to a third embodiment of the present invention is explained hereinafter with reference to the drawings. In this embodiment and the first embodiment, like parts are designated by like reference numerals, and explanation thereof is omitted.

**[0044]** Fig. 5 is a front view of an outdoor unit 10 of an air conditioner provided with the electrical component box according to this embodiment.

**[0045]** In this embodiment as shown in Fig. 5, the electrical component box 17 constituting a first substrate holder and a fixing plate 18 constituting a second substrate holder are separated from each other. The electrical component box 17 is disposed above the partition

plate 13, while the fixing plate 18 is placed on the partition plate 13 on the side of the compressor 11.

**[0046]** By arranging the electrical component box 17 above the partition plate 13 and arranging a control substrate 7 on a side surface of the partition plate 13 in the aforementioned manner, not only can the size of the electrical component box 17 be reduced, but the electrical component box 17 and the control substrate 7 can also be efficiently accommodated within a space delimited by the compressor 11, the partition plate 13, and a rear surface (not shown) and a side surface 16 of the outdoor unit 10, thereby making it possible to reduce the size of the outdoor unit 10.

#### 15 Industrial Applicability

**[0047]** As described hereinabove, because the electrical component box according to the present invention can be reduced in size, it can be effectively utilized as an electrical component box for an air conditioner.

#### Claims

- 25 1. An electrical component box for an air conditioner that includes a compressor and a cooling fan separated from each other by a partition plate, said electrical component box comprising:
  - 30 a first control substrate having an exothermic element mounted thereon;
  - a first substrate holder disposed above the partition plate to hold the first control substrate;
  - a second control substrate having a non-exothermic element mounted thereon;
  - 35 a second substrate holder disposed generally perpendicular to the first substrate holder or generally horizontally on a compressor side with respect to the partition plate to hold the second control substrate; and
  - 40 a set of radiating fins mounted on the first control substrate so as to protrude therefrom on a fan side with respect to the partition plate.
- 45 2. The electrical component box for an air conditioner according to claim 1, wherein the second substrate holder has a slot defined therein into which the second control substrate is inserted.
- 50 3. The electrical component box for an air conditioner according to claim 1 or 2, further comprising a reactor mounted on the second control substrate.
- 55 4. An air conditioner comprising the electrical component box according to any one of claims 1 to 3.

Fig. 1

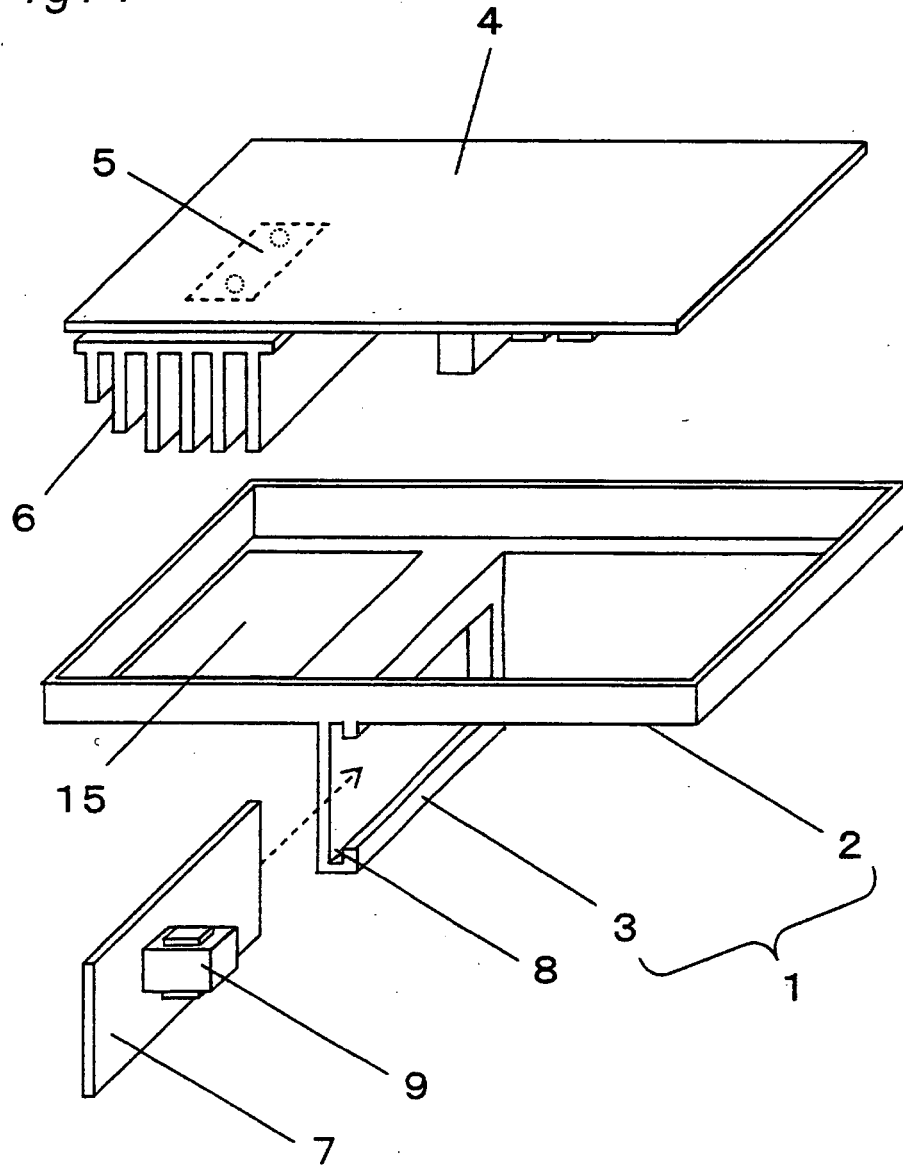

Fig. 2

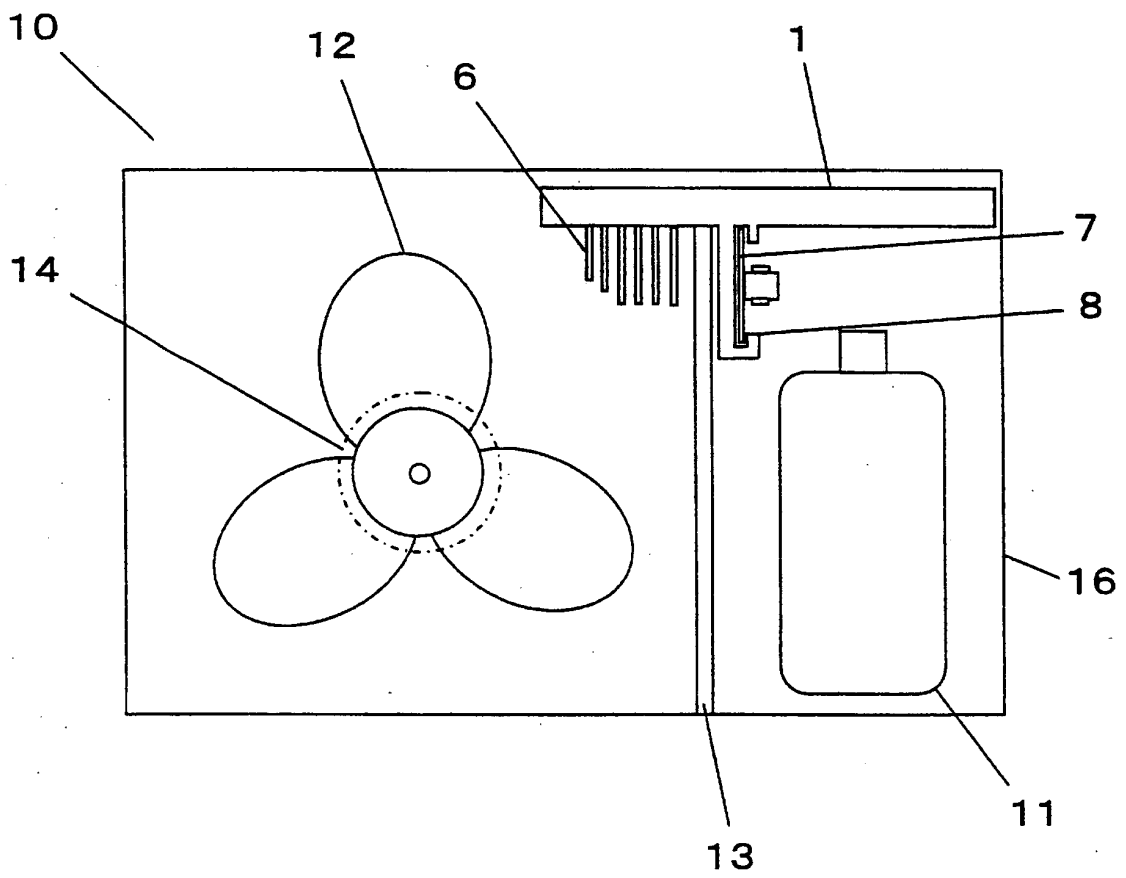

Fig. 3

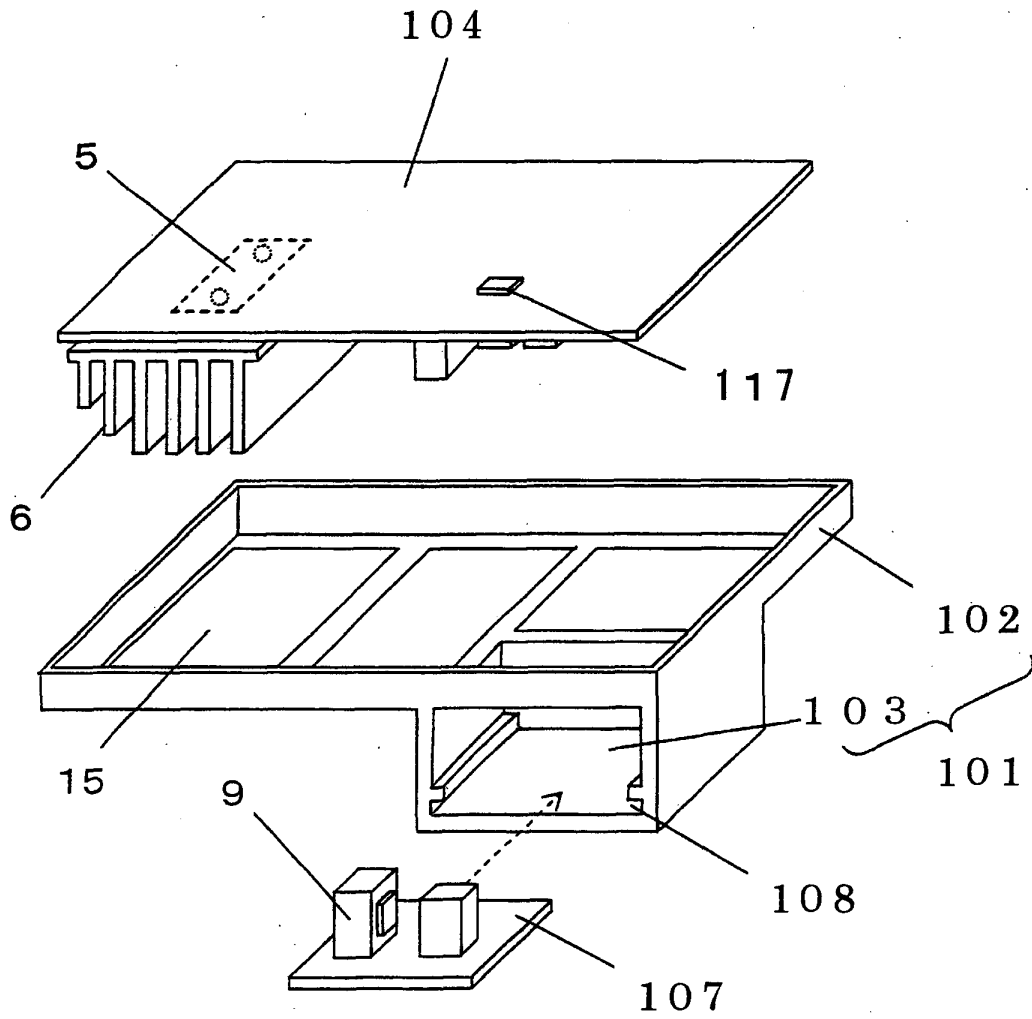

Fig. 4

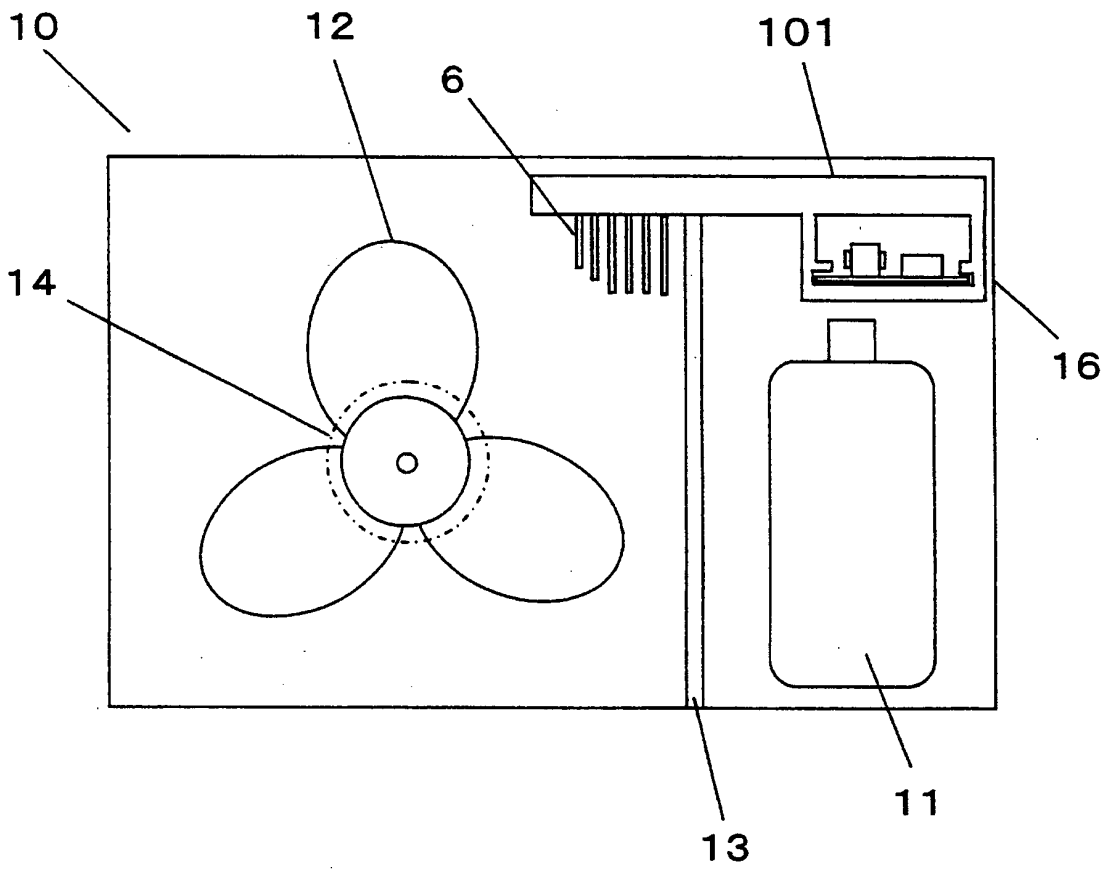

Fig. 5

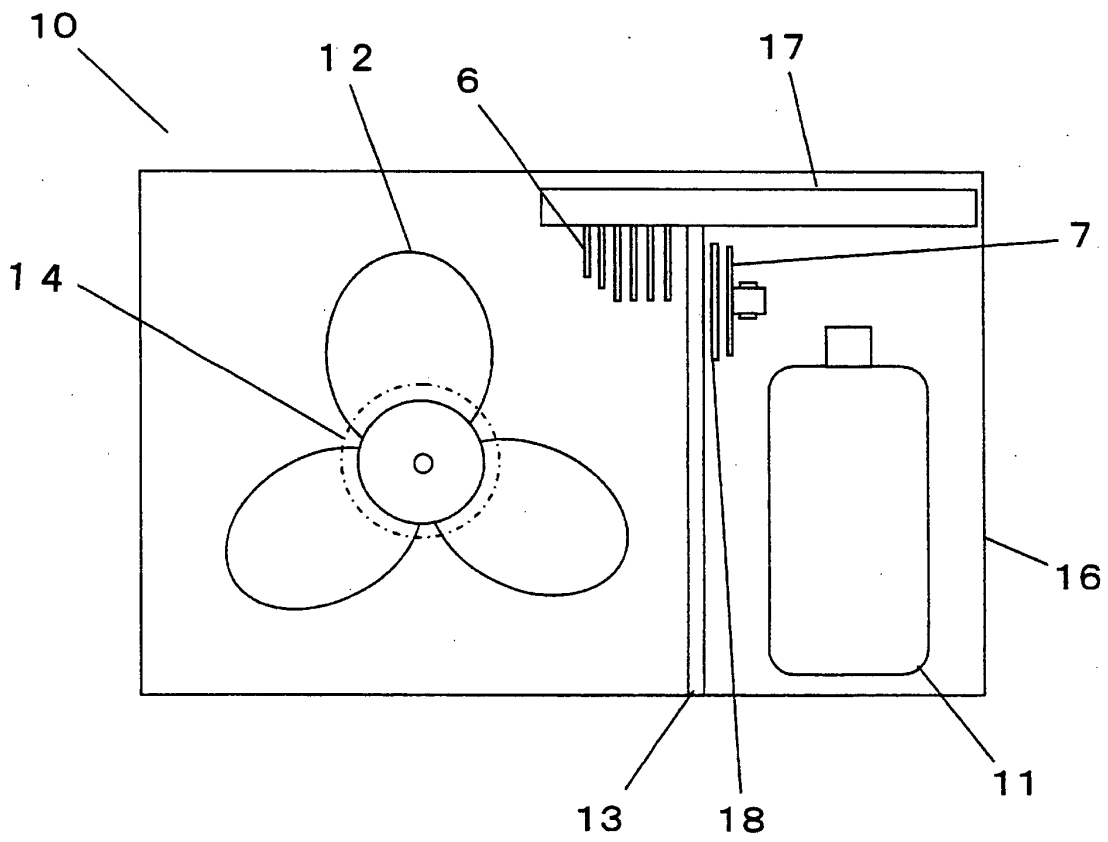

Fig. 6

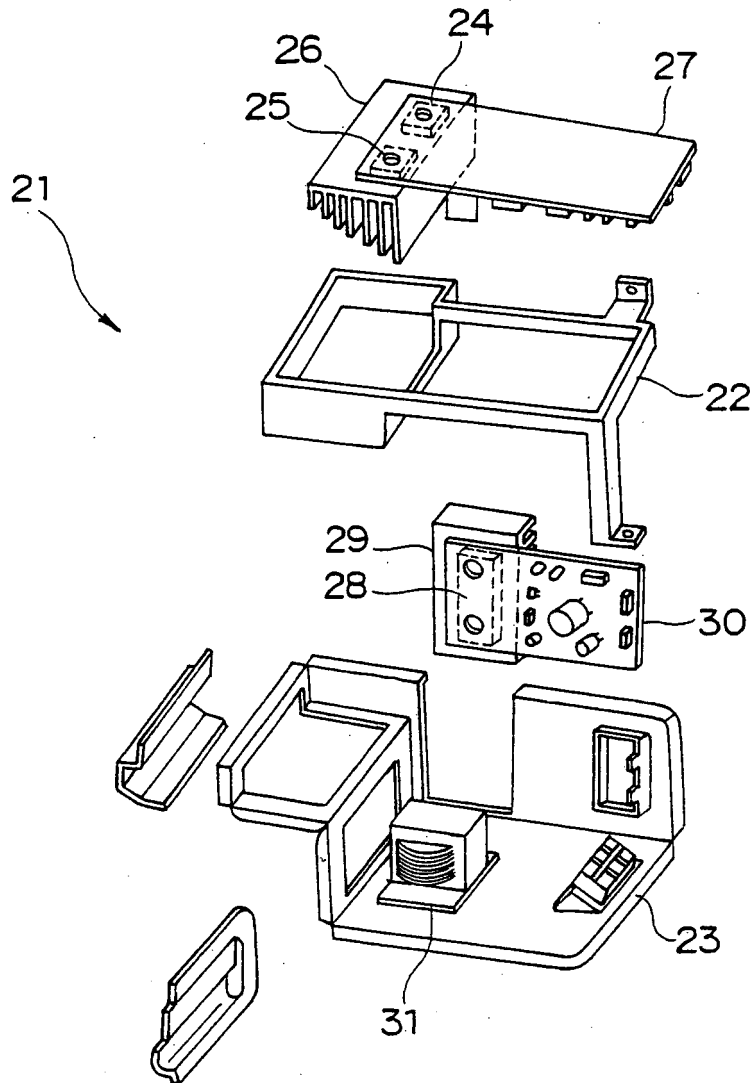
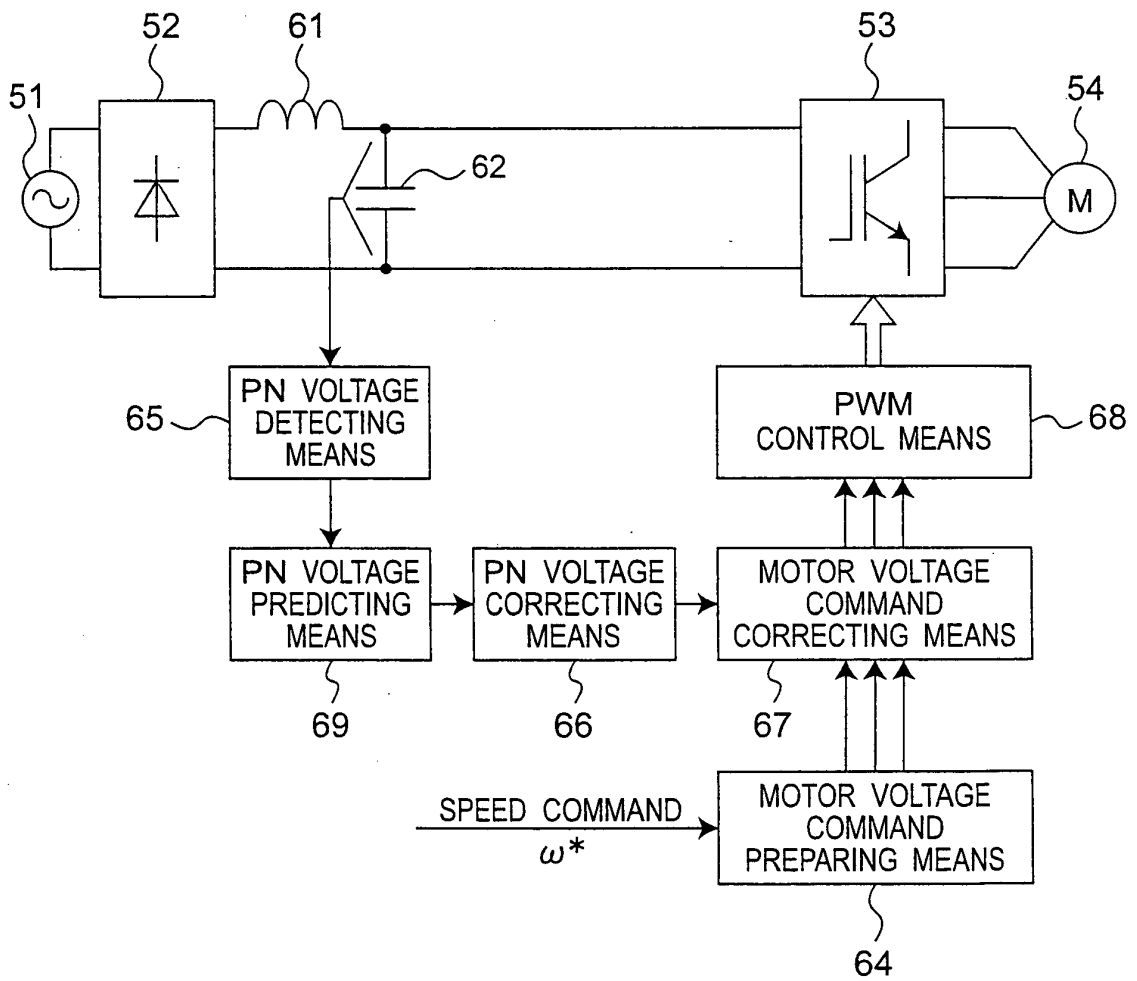

Fig.7



## INTERNATIONAL SEARCH REPORT

International application No.

PCT/JP2008/000841

A. CLASSIFICATION OF SUBJECT MATTER F24F5/00(2006.01) i		
According to International Patent Classification (IPC) or to both national classification and IPC		
B. FIELDS SEARCHED		
Minimum documentation searched (classification system followed by classification symbols) F24F5/00		
Documentation searched other than minimum documentation to the extent that such documents are included in the fields searched Jitsuyo Shinan Koho 1922-1996 Jitsuyo Shinan Toroku Koho 1996-2008 Kokai Jitsuyo Shinan Koho 1971-2008 Toroku Jitsuyo Shinan Koho 1994-2008		
Electronic data base consulted during the international search (name of data base and, where practicable, search terms used)		
C. DOCUMENTS CONSIDERED TO BE RELEVANT		
Category*	Citation of document, with indication, where appropriate, of the relevant passages	Relevant to claim No.
Y	JP 11-63574 A (Mitsubishi Electric Corp.), 05 March, 1999 (05.03.99), Par. Nos. [0015], [0016]; Fig. 1 (Family: none)	1-4
Y	JP 2001-317767 A (Mitsubishi Electric Corp.), 16 November, 2001 (16.11.01), Par. No. [0011]; Fig. 1 (Family: none)	1-4
Y	JP 2000-74422 A (Toshiba Corp.), 14 March, 2000 (14.03.00), Par. No. [0025]; Fig. 8 (Family: none)	2-4
<input type="checkbox"/> Further documents are listed in the continuation of Box C.		<input type="checkbox"/> See patent family annex.
* Special categories of cited documents:		
"A" document defining the general state of the art which is not considered to be of particular relevance	"T" later document published after the international filing date or priority date and not in conflict with the application but cited to understand the principle or theory underlying the invention	
"E" earlier application or patent but published on or after the international filing date	"X" document of particular relevance; the claimed invention cannot be considered novel or cannot be considered to involve an inventive step when the document is taken alone	
"L" document which may throw doubts on priority claim(s) or which is cited to establish the publication date of another citation or other special reason (as specified)	"Y" document of particular relevance; the claimed invention cannot be considered to involve an inventive step when the document is combined with one or more other such documents, such combination being obvious to a person skilled in the art	
"O" document referring to an oral disclosure, use, exhibition or other means	"&" document member of the same patent family	
"P" document published prior to the international filing date but later than the priority date claimed		
Date of the actual completion of the international search 09 June, 2008 (09.06.08)	Date of mailing of the international search report 24 June, 2008 (24.06.08)	
Name and mailing address of the ISA/ Japanese Patent Office	Authorized officer	
Facsimile No.	Telephone No.	

**REFERENCES CITED IN THE DESCRIPTION**

*This list of references cited by the applicant is for the reader's convenience only. It does not form part of the European patent document. Even though great care has been taken in compiling the references, errors or omissions cannot be excluded and the EPO disclaims all liability in this regard.*

**Patent documents cited in the description**

- JP 11063574 A [0007]
- JP 2005304248 A [0007]