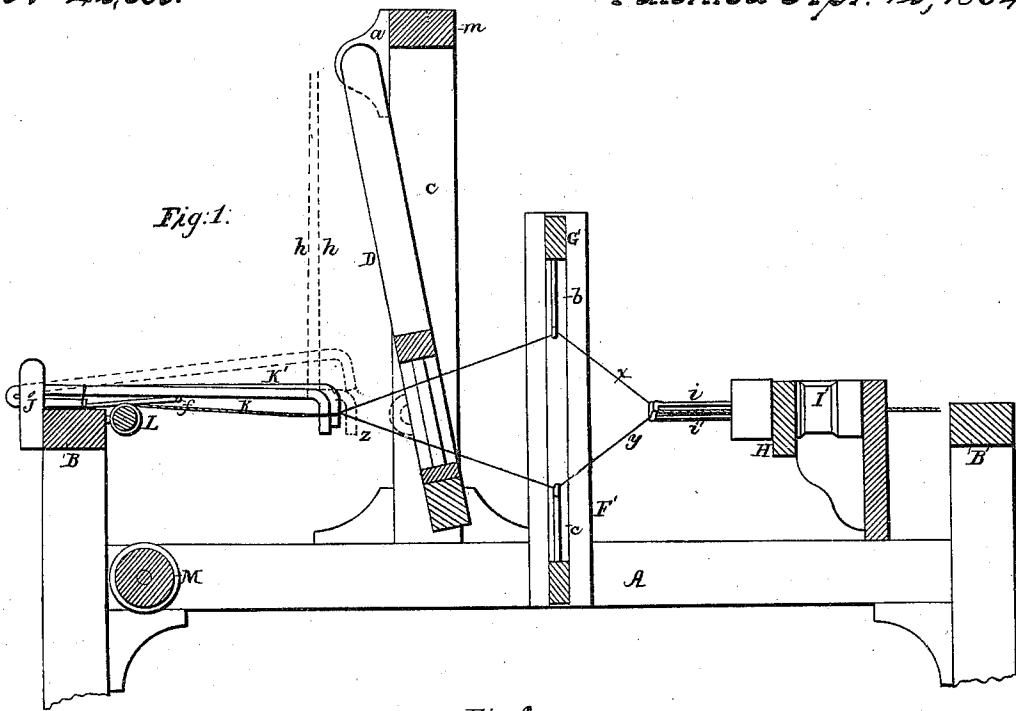


*L. D. Valetton.*

*Loom for Weaving Fringes &c.*

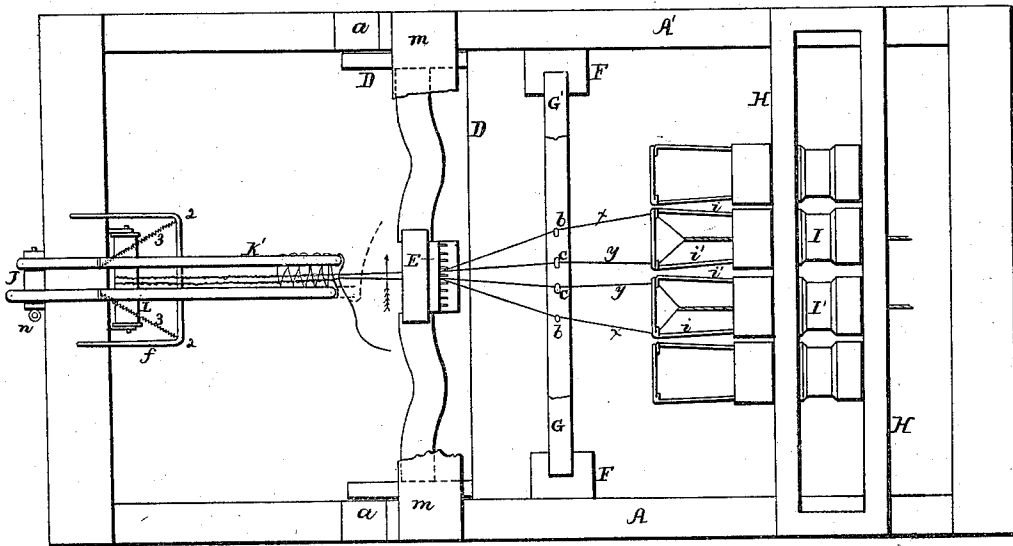
*№ 42,335.*

*Patented Apr. 12, 1864.*

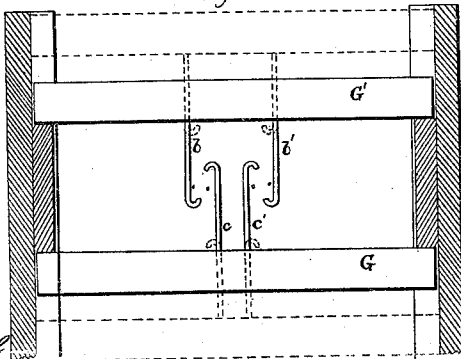


*Fig. 1.*

*Fig. 2.*

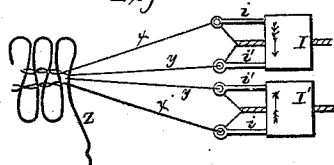


*Fig. 3.*

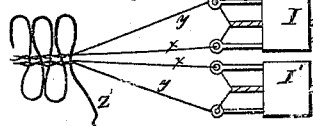


*Witnesses;*  
*Charles Foster*  
*W. Albert Steel*

*Fig. 4.*



*Fig. 5.*



*Inventor;*

*L. D. Valetton*  
*Atty.*  
*Wm. Rowson*

# UNITED STATES PATENT OFFICE.

LOUIS D. VALETTON, OF PHILADELPHIA, PENNSYLVANIA, ASSIGNOR TO  
H. W. HENSEL, OF SAME PLACE.

## IMPROVEMENT IN LOOMS FOR WEAVING TRIMMINGS.

Specification forming part of Letters Patent No. 42,335, dated April 12, 1864.

*To all whom it may concern:*

Be it known that I, LOUIS D. VALETTON, of the city and county of Philadelphia, State of Pennsylvania, have invented certain Improvements in Looms for Weaving Braids or Trimmings; and I do hereby declare the following to be a full, clear, and exact description of the same, reference being had to the accompanying drawings, and to the letters of reference marked thereon.

My invention relates to a mode of producing braids or trimmings having a succession of loops on one or both sides; and my invention consists in the employment of one or more rods, or their equivalents, arranged and operated in conjunction with the warp and weft threads, substantially as described hereinafter.

My invention further consists in the employment of hooked rods arranged and operated in conjunction with certain spindles, hereinafter described, for distending the warp-threads.

In order to enable others skilled in the art to make and use my invention, I will now proceed to describe its construction and operation.

On reference to the accompanying drawings, which form a part of this specification, Figure 1 is a sectional elevation of part of a loom with my improvements; Fig. 2, a plan view; Fig 3, a detached sectional view, and Figs. 4 and 5 diagrams showing the progressive formation of the trimmings.

Similar letters refer to similar parts throughout the several views.

A and A' are portions of the two side frames of a loom, each frame having an upright, C, and the two frames being connected together by the breast-beam B, warp-beam B', cross-bar *m*, and other stays, which it has not been deemed necessary to illustrate and describe.

To the verticals C and C' are secured suitable plates or brackets *a*, and to these is hung the lathe D, having a reed, E, of a character suitable for the fabric to be produced.

In the vertical guides F F', secured to the side beams, A A', slide the bars G and G', to which a vertical reciprocating motion is imparted from any operating part of the loom by suitable appliances, and from the under

side of the bar G' and the upper side of the bar G project the hooked rods *b* and *b'* and *c* and *c'*.

In a stationary frame, H, at the rear of the loom, turn the spindles I and I', to which an intermittent revolving motion is imparted by any suitable mechanism. From the ends of each spindle project two rods, *i* and *i'*, each rod having at the end an eye, the use of which will be described hereinafter. Two rods, K and K', are loosely connected by a pin, *n*, to a slotted bracket, J, secured to the breast-beam, the outer end of each rod being bent down at right angles, as shown in Fig. 1. A cord or cords, *h*, are secured to each rod, and these cords are so operated from any working part of the loom as to be the medium of imparting the movements described hereinafter to the rods K and K'. From the breast-beam B projects a bent rod, *f*, upon which the rods K and K' rest, and to each corner, 2, of this rod is secured one end of a spring, 3, the other end of which is attached to one of the rods K. A roller, L, turns in brackets projecting from the inside of the breast-beam, and below this roller revolves the take-up roller M. Each pair of threads *x* and *y* of the four threads, which constitute the warp in the present instance, is twisted together, and each of the doubled threads is conducted from the spool or bobbin, upon which the supply is wound, through one of the spindles, I, in front of which the two threads are separated, the thread *x* passing through the eye of the rod *i* and the thread *y* through the eye of the rod *i'*. The threads from each spindle pass from the rods *i* through the reeds E, and thence over the roller L to the take-up roller M. The weft-thread *x* is shown by red lines in the drawings, and is carried by a shuttle similar to those used in ordinary coach-lace looms.

Operation: In the drawings, a portion of trimming is represented as having been formed, the weft-thread *x* passing from the shuttle between the warp-threads *x* and *y*, and round the end of the rod K' to the fabric, the end of the rod K being in a loop of the trimming, as best seen in Fig. 2. The bars G are also represented as being at the limit of their outward motion, the warp-threads *x* having been caught by the hooked rods *b* and the threads *y* by the hooked rods *c*. To continue the operation of the loom,

the lathe is carried forward so as to beat up the weft, after which the bars G and G' are brought to the position shown in Fig. 3, so that the threads *x* and *y* are released and occupy the position shown in Fig. 4. The spindles I and I' are now turned one-half of a revolution in the direction of their arrows, so that the two threads *x* and *y* from each spindle shall be twisted at the rear of the weft-thread in the manner shown in Fig. 5, the weft-thread being thus interlocked with the warp-thread. The rod K is now raised by the cord *h*, and as it escapes from the loop it is thrown forward by the action of the spring 3 to the position shown in red lines, Fig. 1, so that when the said rod, at the next movement, drops to the position shown by dotted lines its bent end shall be in the rear of the weft-thread *z*. The lathe is then moved back and the warp-threads distended, the thread *x* being depressed and the thread *y* elevated, owing to the change in the position of the threads effected by the partial revolution of the spindles I and I'. The shuttle now passes between the warp-threads in the direction pointed out by the arrow, Fig. 2, folding the thread round the end of the rod K and carrying it to the position shown by dotted lines, Fig. 2. The lathe now beats up the weft-thread, the bars G again assume the position shown in Fig. 3, and the warp-threads are twisted as before. The rod K' is now raised by the cord *h* and thrown forward by the spring 3 to the position shown by red lines, Fig. 1, so that it shall descend with its bent end in the rear of the weft-thread, which is drawn round it by the next movement of the shuttle. As the lathe again beats up the weft, the roller M takes up sufficient of the work to carry the rods K back to the position shown in Figs. 1 and 2, so that when they are released from the loops the springs 3 shall throw them toward the lathe, as before. It will be seen that each time the weft thread is carried round the end of one of the rods K, and secured by the twisting of the warp-threads and beating up of the latter, a loop of the weft-thread is formed on one side of the warp, a similar loop being

formed on the other side, when the weft-thread is carried round the end of the other rod, the continuation of these loops, secured by the warp-threads, forming the trimming seen in Fig. 4. It will also be seen that by using one rod, K, on one side of the warp and allowing the weft-thread to be drawn close to the warp on the opposite side the trimming will be formed with loops on one side only.

Instead of two rods, K, one only may be used for forming loops on both sides of the fabric by causing the rod to be so operated that it will move from one side of the warp to the other.

The pattern of the fabric may be varied by using additional shuttles and by the employment of additional warp threads of different colors.

In many cases the revolving spindles I and hooks *b* and *c* may be dispensed with and the ordinary harness and treadles used. When, however, the warp-threads are twisted to secure the weft, the ordinary harness cannot be employed, and without the hooks *b* and *c* it would be necessary to arrange the rods *i* so far apart in order to distend the warp sufficiently for the shuttle to pass, that a limited number only of spindles could be used in the space which they must occupy.

I claim as my invention and desire to secure by Letters Patent—

1. One or more rods, K and K', or their equivalents, arranged and operating in conjunction with the warp and weft threads of a loom, substantially as and for the purpose set forth.

2. The hooked rods *b* and *c*, arranged and operating in conjunction with the spindles I, for distending the warp-threads, substantially as described.

In testimony whereof I have signed my name to this specification in the presence of two subscribing witnesses.

LOUIS D. VALETTON.

Witnesses:

HENRY HOWSON,  
JOHN WHITE.