



(72) KATAEV, Vladimir Alexandrovich, RU

(72) ANISIMOV, Sergey Nicolaevich, RU

(71) STINS COMAN CORPORATION, RU

(51) Int.Cl.⁶ G06F 19/00

(30) 1999/02/10 (RU 99102249) RU

(54) **METHODE ET SYSTEME UTILISANT UN DISPOSITIF DE JEU**

(54) **METHOD AND SYSTEM USING A GAME-PLAYING DEVICE**

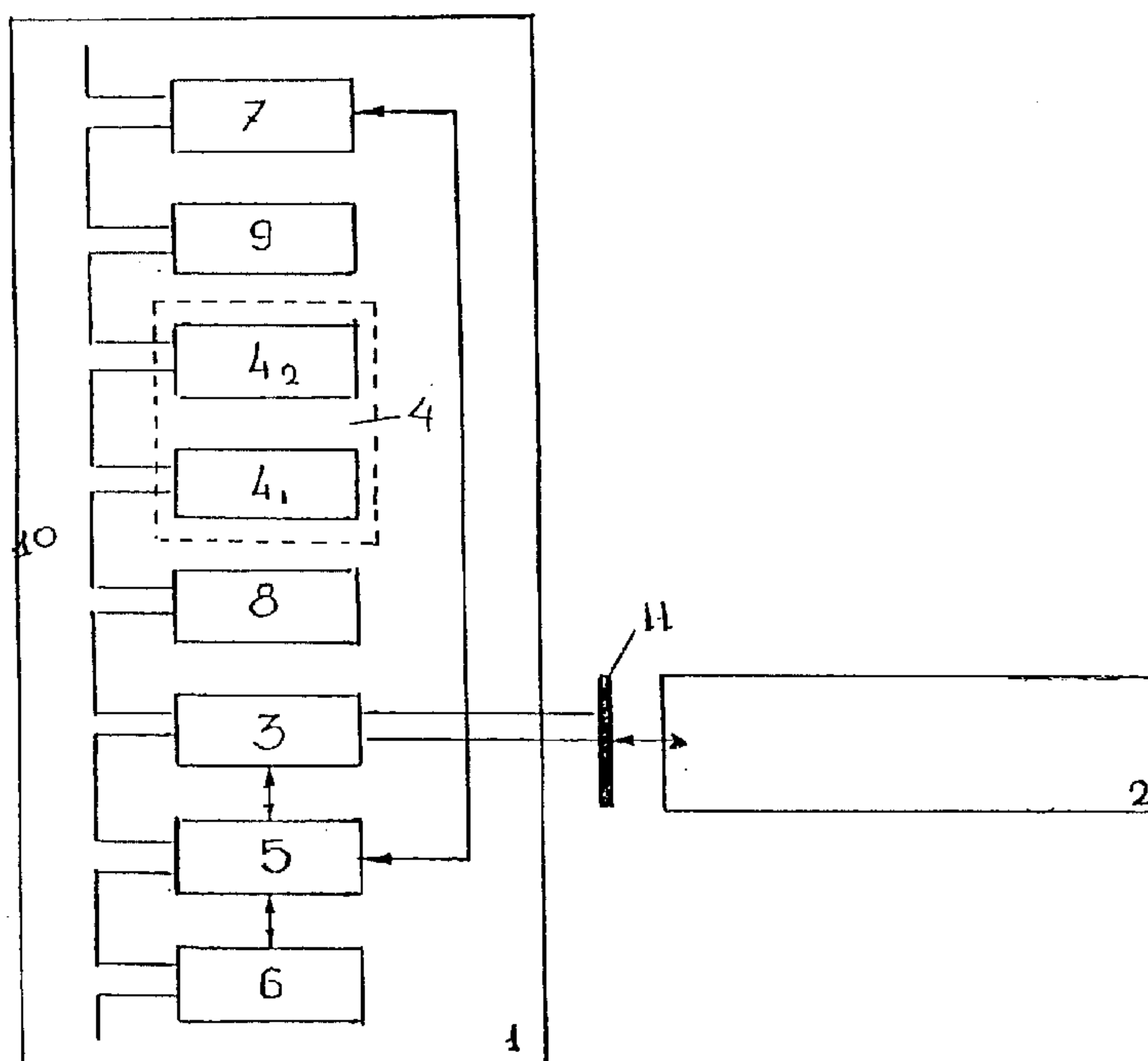

(57) Disclosed is a system and a method which enable playing a game or any part thereof and running various operations connected to the game or its stages, as well as running various operations not directly connected to the game. In these system and method, a stand-alone, portable game-playing device enabling the running of operations and/or games is incorporated with a data carrier for reading and recording of the information. The game-playing device may include data carrier authentication tools, a processing unit, a display, a data and commands input device, operation and/or game identification code reading tools, a micro-controller for running the operations and/or game play, memory, and buses connected with the processing unit, display, data and commands input device. In use, the data carrier is authenticated by means of the game-playing device. The possibility of operation and/or play is then determined using that game-playing device and data carrier and the operation and/or game is run by means of the stand-alone, portable game-playing device. The possibility of operation and/or play by means of the game-playing device is determined by reading identification codes from the data carrier, and transferring these codes to the micro-controller of the game-playing device for their identification. If the codes permit, the operation and/or game is then run. It is a particular feature of the invention that a game playing machine and associated card can be used for totally unrelated operations, such as a reader and identification card for access to a secure location, and so on.

ABSTRACT

Disclosed is a system and a method which enable playing a game or any part thereof and running various operations connected to the game or its stages, as well as running various operations not directly connected to the game. In these system and method, a stand-alone, portable game-playing device enabling the running of operations and/or games is incorporated with a data carrier for reading and recording of the information. The game-playing device may include data carrier authentication tools, a processing unit, a display, a data and commands input device, operation and/or game identification code reading tools, a micro-controller for running the operations and/or game play, memory, and buses connected with the processing unit, display, data and commands input device. In use, the data carrier is authenticated by means of the game-playing device. The possibility of operation and/or play is then determined using that game-playing device and data carrier and the operation and/or game is run by means of the stand-alone, portable game-playing device. The possibility of operation and/or play by means of the game-playing device is determined by reading identification codes from the data carrier, and transferring these codes to the micro-controller of the game-playing device for their identification. If the codes permit, the operation and/or game is then run. It is a particular feature of the invention that a game playing machine and associated card can be used for totally unrelated operations, such as a reader and identification card for access to a secure location, and so on.

330-99AP.doc D-7 27.4.1999

METHOD AND SYSTEM USING A GAME-PLAYING DEVICE

5 The present invention relates to games, stages of games and/or other operations performed by game-playing devices and data carriers. Game playing and/or other operations are performed by means of a game-playing device, which operates in an off-line mode, independently of a host station. The device can utilize "smart" or ordinary data carriers for recording results of operations and games, as well as data carriers incorporating game programs and other programs to be carried out by the game-playing device.

10

BACKGROUND OF THE INVENTION

A game method using a portable credit card and a system for implementation thereof are known from prior art, wherein a credit card is authenticated and the possibility of playing is verified. The game is subsequently played by means of a stand-alone, portable game-playing device. The results of the game are recorded on the credit card by means of the game-playing device which is constructed as an off-line functioning device. A "smart" memory card is used as the credit card. (RU 2100840)

20 Though this method and system are user-friendly, they do not enable selection of a game or game stage, or exertion of influence on the course of the game.

25 Closest to the proposed invention is a system and game-playing device using a debit card. The game method consists of authenticating the debit card by means of the game-playing device, the game-playing device being equipped with the device enabling reading and recording of the information contained in the memory of the debit card, which is made as a smart card. The possibility of playing is determined by reading the initial credit information from the smart card. If the result is positive, the game is played, following which the resulting data are recorded in the smart card memory (RU 2105586).

30 The known method, system and game-playing device enable the user to play the game either partially or completely, and to record the results of the game as a whole or any part thereof in the smart card memory.

However, the described method, system and game-playing device have a limited application

area, allowing only the playing of the game and the recording of its results, or the results of any stage of the game, for submission to a competent institution in order to receive a prize.

SUMMARY OF THE INVENTION

5 The present invention enables playing a game or any part thereof, and running various operations connected to the game or its stages, as well as running various operations not directly connected to the game. These operations can include operations related to obtaining additional information about the cardholder, and operations totally unconnected to the game, such as identification of the cardholder or a competent institution for predefined tasks. The
10 present invention also permits using a stand-alone, portable game-playing device for reading game programs and/or operating programs from the data carrier and running said programs or, alternatively, selecting a game or operation from the memory of the game-playing device or of the data carrier.

15 The present invention enables determination of the possibility of operation and/or game play and control of the region of sale and/or manufacture of the game-playing device and the data carrier used, as well as statistically pre-determining the percentage of winning games.

Furthermore, the invention enables encryption of the data entered into the data carrier,
20 whenever necessary, recording the operation program from the memory of the game-playing device to the data carrier, or reading and recording the information from another data carrier to the memory of the game-playing device or the data carrier, by means of the reading-and-recording tools.

25 The objective of the proposed system of operations and/or game playing is attained by incorporating a stand-alone, portable game-playing device enabling the running of operations and/or games, with a data carrier for reading and recording of the information. The game-playing device includes data carrier authentication tools, a processing unit, a display, a data and commands input device, operation and/or game identification code reading tools, a
30 micro-controller for running the operations and/or game play, memory, and buses connected with the processing unit, display, data and commands input device.

The objective of the proposed method of operations and/or game playing by means of the data carrier is attained by authenticating the above data carrier by means of the game-playing

device, determining the possibility of operation and/or play using that game-playing device and data carrier, and running the operation and/or game by means of the stand-alone, portable game-playing device. The possibility of operation and/or play by means of the game-playing device is determined by reading identification codes from the data carrier, and transferring
5 these codes to the micro-controller of the game-playing device for their identification. If the codes permit, the operation and/or game is then run. It is a particular feature of the invention that a game playing machine and associated card can be used for totally unrelated operations, such as a reader and identification card for access to a secure location, and so on.

10

BRIEF DESCRIPTION OF THE DRAWINGS

The proposed method, system and stand-alone game-playing device are illustrated in the
15 following Figures:

Figure 1 shows the functional design of one embodiment of the proposed system for implementing the game method by means of a data carrier.

20 Figure 2 shows one embodiment of a stand-alone, portable game-playing device according to the invention.

DETAILED DESCRIPTION OF THE INVENTION

The present invention relates to a method and system for performing operations and/or playing electronic games on a portable game-playing device. The present method is characterized by the combination of game related operations and non-game related operations which can be performed by a single device which, in the past, was restricted solely to game playing functions. In addition, the present method provides regional access codes and game selection codes which limit the data carriers which can be utilized in particular game-playing devices, or restrict the games which can be played using a particular data carrier. Furthermore, the present invention permits the manufacturer to pre-select the statistical distribution of wins and losses during playing of each game in the game-playing device.

The present invention enables the independent playing of games, in any convenient location, without any technical control and/or management tools, and without requiring connection to a central data base or other main control system, and without addressing any host processor for running the game. In addition, the device can be utilized as an independent verification device for identifying cardholders in various situations. It also enables receipt of prizes from a competent institution or authority.

Referring now to Fig. 1, there is shown a schematic illustration of the functional design of one embodiment of the system of the present invention, including an electronic game-playing device 1 intended for running the operation and/or game. A data carrier 2 can be inserted into device 1 for inputting a program to be run by the device, and/or for recording or reading results of an operation or game performed by the device. By means of game-playing device 1, a user or leaseholder of the device 1 can play games, or run any other operations which the user of the device wishes to perform, utilizing data carrier 2.

Data carrier 2 can be any card which can carry data required for playing a game or performing the desired operations, including, but not limited to, a conventional credit card, debit card, "smart" card, or any other card or element on which points, or wins and losses, or results of other operations, can be indicated by the game-playing device for later reading, or which serves to identify the cardholder or a characteristic of the cardholder. It can contain a microprocessor 12 connected with the interface chain 16 and the memory blocks 13, 14, and 15 and equipped with the operation or game program.

Data carrier 2 can be disposable, i.e., for one-time use, or it can be usable a number of times, by entering new data onto a used data carrier. If the user intends to play a game for cash or to run any money-related operation, the data carrier can comprise a smart payment card or a special-purpose chip with a microprocessor system protected from any unauthorized access,
5 such as that described in US 5,179,517.

The data carrier can be used in the game-playing device both as the game playing means and as the device for reading and recording of information, including that from the keypad of the game-playing device. Moreover, the data carrier can be used for storing information relating
10 to a game, any stage thereof, game results or other data necessary for the cardholder. Thus, it will be appreciated that there can be two combinations according to the present invention - in one case, the game-playing device is programmed in advance to run all the desired operations and games, and the data carrier is a passive data carrier to be read from or written to by the game-playing device. In the second case, the game-playing device is essentially a "dumb"
15 device with a memory, and all the programs and required data are stored on the data carrier, for transfer to the game-playing device memory at the time of use. In the latter case, a competent institution or authority, such as the data carrier manufacturer, the person selling the data carrier, a bank, a secure area for which identification by means of the device and data carrier are required, etc., enters information pertaining to the identity or credit of the data
20 carrier holder into the data carrier. Preferably, this information is protected from any unauthorized access. It will be appreciated that alternatively a combination of the two is possible, where some programs are pre-recorded in the device, and others are stored on the data carrier for later use by the device. Thus, the game-playing device of the present invention is multi-purpose, and can be programmed to carry out any sort of program, as selected by the
25 user, which utilizes a data card, and combines operation and game playing capability in a single device, which was avoided in the past due to security concerns.

According to the present invention, it is possible to use a card originally intended for other purposes, such as a conventional credit or debit card, a smart card, etc., as a data carrier 2.
30 Such a card can be used in the proposed method if its memory capacity allows storage of the information required for this method, and the protection of the information is adequate for the game-playing device.

In addition, the data carrier carries data for specific operations to be carried out by the

particular game-playing device. Thus, the data carrier can serve as a club membership card, identifying the cardholder as an authorized member when inserted into the game-playing device; it can be a driver's license or other license, which can be verified, as by a policeman, using the game-playing device; it can be a secure entry card, permitting entry of the cardholder into a hotel room, parking lot, apartment building, when the locking mechanism include a game-playing device as card reader; it can serve to identify the holder of a safety deposit box; or it can include any other data which can be read or written on the card by means of a game-playing device.

10 It is a particular feature of the invention that the game-playing device of the present invention can be used to play games during the time it is not being used to perform other operations. Thus, for example, a hotel guest, after using the data carrier to enter his room, can use the data carrier to play an electronic game while in his room.

15 Referring again to Fig. 1, game-playing device 1 contains a data carrier authentication device 3, for determining whether a data carrier entered into the device is authentic and is authorized to run the selected program on that particular device. It also contains a processing unit 4, for running the various games and operations. According to one embodiment of the invention, processing unit 4 includes a control processor 4₁ and a separate display processor 4₂, as
20 described below. A data and commands input unit 6 is provided, including an interface, such as a keypad, for permitting the user to input commands to the device. A reader 5 for recording and reading of information, including operation and/or game identification codes, to and from the data carrier is connected with the data and commands input unit. A display 7 is provided, which can be a single display, or a number of separate displays, for providing visual output
25 for the user, or to display a game. The device further includes a micro-controller 8, and a memory 9. All these elements are interconnected by means of the game-playing device buses 10.

Figure 2 illustrates schematically one embodiment of a stand-alone, portable game-playing device 20 useful in the present invention. Game-playing device 20 includes a keyboard or keypad 11 forming part of the data and commands input unit (not shown), and display panels 7₁ and 7₂ (the machine can be equipped with several display panels). It also includes a slot 12 for input of a data carrier. The game-playing device also can be equipped with a few devices for recording and reading of information from the data carrier (not shown in Figure 2)

connected with the data and commands input unit and buses of the game-playing device.

Operation of the device according to the present invention is as follows. The operation and/or game is begun by connecting the data carrier 2 with the game-playing device 1 by inserting
5 the data carrier 2 into the slot 12. The data carrier authentication device 3, depending upon its construction, verifies the inserted data carrier independently, or by transferring authentication information to micro-controller 8 and processing unit 4, in any of a number of possible ways.

The data carrier authentication device 3 can verify the data carrier by reading authentication
10 data on the card, by means of reader 5, or by means of the processing unit 4 program tools. The results can be shown on the display board 7₁ of the display 7. Alternatively, the data carrier can be authenticated by conventional tools used in ATMs (Automated Teller Machines). Thus, the system can incorporate an authentication program verifying a secret access code stored in the data carrier by the game-playing device. According to one
15 embodiment, when the secret access code in the data carrier is identified as the code stored in the game-playing device, the operation will be run, or the game will be played. Or, authentication can be performed by reading an authentication program from the data carrier to memory 9 of the game-playing device, followed by a verification procedure by the game-playing device by means of the above program. This can include, for example,
20 providing an algorithm on the data carrier including a list of operations which must be carried out by the game-playing device. If all the operations can be carried out successfully, the data carrier is authenticated.

The results of the determination whether the data carrier is authentic can be displayed via the
25 game-playing device. Words indicating that the user can proceed to the next step can be shown on the display screen, an audio indication can be provided, or even a tactile indication, such as vibration of part of the game-playing device.

It is a particular feature of the present invention that the data carrier authentication device not
30 only can determine whether the data carrier is authentic (and not forged), but also can determine whether the particular data carrier is permitted to operate the specific game-playing device into which it has been inserted, and which games it is authorized to play. Thus, following authentication of the data carrier by means of the game-playing device, the possibility of operation and/or play is determined. This can be accomplished in any suitable

manner, such as by storing a regional code or a plurality of game codes in the data carrier and in the memory of the game-playing device and, only if the codes on the particular data carrier are identified visually or by the specific game-playing device when the codes are compared will operation be permitted. Such game codes can prescribe game conditions, such as
5 limitations of the minimum credit required to play the game, maximum winnings or losses available on the card, restrictions having to do with age of the cardholder, such as games not suitable for minors, and so on. These codes can be entered into the game-playing device and/or the data carrier at the time of manufacture or sale, or by a competent institution in the framework of recording the available funds to the memory of the data carrier. The
10 game-playing device may contain a data carrier regional or other code reading device including a software module.

The results of the operation and/or game play can be recorded in the data carrier for later use, such as collection of a prize from the competent institution, or authorization of passage, or
15 recording a traffic violation, etc., depending upon the particular operations programmed into that game-playing device.

Should the sign read from the data carrier be a game sign, the game-playing device runs the game according to the procedures described in the prototype, i.e., a player may play a game
20 by means of the game-playing device via the data and commands input block and the display. When necessary, he can record the game result to the data carrier by means of reader 5.

If the cardholder intends to play a cash game, information on his credit standing stored on the data carrier can be read and displayed by means of the reader 5. For example, the user may
25 use keypad 11, or other user interface, to enter a code, or select the credit standing operation. In this case, the information is read by means of the reading program run by the micro-controller 8 from memory 9 in the game-playing device 1. The display 7 indicates the amount of credit available for the user. If this amount is sufficient to play the game, the micro-controller 8 starts running the game, by contacting the processing unit 4. Alternatively,
30 display 7 can indicate a list of operations and/or games available on the game-playing device, and the user can select the operation and/or game he wants by means of the keypad 11.

According to one embodiment of the invention, credit-related information can be read from one data carrier 2, while information on the results of the game can be recorded into the

memory of another data carrier. Such a system is applicable if the player has not yet spent all initial credit, as recorded in the memory of one data carrier, such as a smart card, and applies to the competent institution for additional credit without this smart card at hand. In such a case, the new data on the credit, the game or game stages program, the operation program, the results of the game or its stages, the games played, and the other information, which the user or the owner chooses to store in the data carrier, will be read from the memory of another data carrier to the memory of the game-playing device. Once the game is over, the total result, with allowance made for both credit values, is recorded into the memory of either data carrier.

10 For this purpose, the game-playing device can contain an additional reader (not shown in the Figures) connected with the buses of the game-playing device. In this case, the micro-controller 8 shall provide for the operation with all data carriers.

Game stages are performed similarly. By means of the data and commands input block, the user may prescribe the desired mode for micro-controller 8 by means of block 6, e.g., he may run one or a number of stages under certain conditions. The game-playing device subsequently plays the game stages or the whole game under these conditions, and records the results to the data carrier 2. Alternatively, subsequent stages of a game can be played using a second data carrier, if desired.

20

It is a particular feature of the invention that the game-playing device or the data carrier can be programmed to provide a selected statistical distribution of game results, i.e., wins and losses. This feature can be used in a promotional campaign, for example, where a first batch of devices or data carriers can provide an 80% probability of winning, to generate interest in playing, a second batch can reduce the probability to 50%, once many players have been attracted to the games, and a third stage can be reduced again to a 30% likelihood of winning. Each batch can include a different code, which is identified by the data carrier authentication device, in order to permit playing with that data carrier and/or game-playing device. These and other conditions, such as colors on the display, heights of bids in games of chance, etc. can be pre-set during programming.

30

If desired, in order to protect the information stored in the memory of the data carrier 2 from any unauthorized access, any conventional information protection tools can be used.

Micro-controller 8 controls the operation of various units of the game-playing device connected thereto without changing the information passing through the micro-controller. It can also contain a subprogram for verifying the data carrier. In the proposed game-playing device, micro-controller 8 controls the data and commands input block, the reader 5, the display and the processing unit.

The display processor 4₂ uses a program or programs of interaction with the data and commands input block 6, and the programs enabling display of the course and result of the game on the display 7. Moreover, display processor 4₂ can display signs or list of signs of the operations read from the data carrier 2 by the reader 5. Thus, display processor 4₂ is connected with control processor 4₁, micro-controller 8, data and commands input block 6, and display 7. The specific configuration of these programs depends on the configuration of the blocks 6 and 7 (e.g., keypad and LCD display, or keyboard and ELT monitor, or any other combination of these or other input-output tools available) on the one hand, and on the specific features of the programs used in the selected operations and/or games, on the other hand. These specific features may relate to specific images sent to the display 7 (such as a drawing of playing cards, or sounds accompanying various game situations).

Another possibility according to the present invention is that the device can be programmed so that a number of players can play simultaneously on a single device. In one case, each player has a data carrier which is inserted into the game-playing device for authentication and transfer of points. The device now acts like a croupier, for example, for games of chance. Each player plays, in turn, and the appropriate points are recorded on the card of the winner and deleted from the cards of the losers. According to another possibility, a number of card readers can be provided in the game-playing device, one for each data carrier.

Alternatively, a special interface can be provided to permit coupling between two or more devices. In this case, two or more player can play, one against the other, while each player plays on his own device. In this case, only the results and winning or losing points are transferred between devices and recorded on the respective data carriers.

Should the user wish to perform other operations (apart from the game or its stages), he acts as follows:

Using the display and the data carrier 2, the reader 5 is able to read a list of operations or types of games which can be run by the game-playing device and the data carrier 2.

In this case, the user may select an operation and a relevant command by means of the data and commands input block 6. Since the game-playing device is based on conventional processing and program tools, the operations which do not relate to games or their stages are run by means of conventional operation programs.

A number of non-limiting examples of programs the game-playing device can run are as follows. It will be appreciated that these include both those used for game playing and those for other operations.

- identification of the data holder, perhaps with the addition of a photograph;
- verification of solvency of the holder of the data carrier;
- determination of the extent of credit;
- 15 - determination of a regional code of the data carrier;
- determination of a regional code of the game-playing device;
- reading of the operation program;
- authorization of a portable data carrier;
- authorization of a competent institution or authority;
- 20 - recording of information from the memory of the game-playing device to the data carrier;
- recording of the information to the data carrier by means of the keypad or other interface of the data and commands input block;
- reading information stored in the data carrier;
- reading at least one game program from the data carrier;
- 25 - recording a game or game stage results;
- playing a game for a cash prize;
- playing a game for points;
- authorization of entry into a secure location;
- determination whether the cardholder holds a certain license;
- 30 - determination whether the cardholder is a member of a certain organization.

Alternatively, any other suitable operations can be run by the game-playing device and data carrier.

Thus, the system of the present invention enables running certain operations related not only

to reading and recording the results of the game or any stage thereof, but to reading and recording various information packages pertaining to the cardholder or a competent institution or an independent unit, by means of a data and commands input station and tools for recording the information in the data carrier.

5

Moreover, the present invention enables the user to re-record the program of certain data carrier-related operations from the data carrier (i.e., from card to card, or from card to device), such as verification of solvency by means of a certain program, determination of the extent of credit, selection of the game and/or game stage stored in the memory of the game-playing
10 device processing unit and/or in the memory of the data carrier.

While the invention has been described hereinabove with respect to insertion of a data carrier into a slot in a game-playing device for reading of the data carrier, it will be appreciated that physical contact between the device and the data carrier are not required. Rather, any
15 conventional means of transferring data between the game-playing device and the data carrier can be utilized, including infrared and other methods which require no physical contact.

It will be appreciated by those skilled in the art that the invention is not limited to what has been shown and described hereinabove by way of example. Rather, the scope of the invention is limited solely by the claims which follow.

CLAIMS

1. A method of operating a game-playing device by means of a data carrier comprising the steps of:

- 5 providing a stand-alone, portable game-playing device capable of selectably running an operation and running a game;
authenticating said data carrier by means of the game-playing device; and
determining the possibility of running a selected operation or game on the game-playing device.

10

2. The method according to claim 1, further comprising the step of running the operation or game on the stand-alone, portable game-playing device.

3. The method according to claim 1, wherein the step of determining the possibility of
15 running the operation or game includes reading operation or game identifying signs from the data carrier, followed by transfer of the read identifying signs to a micro-controller in the game-playing device for their identification.

4. The method according to claim 1, wherein the step of determining the possibility of
20 running the operation or game includes reading operation or game identifying signs from the game-playing device, followed by comparing the identifying signs in the game-playing device with identifying signs in the data carrier.

5. The method according to claim 1, wherein the step of authenticating the data carrier
25 includes reading operation or game identifying signs from the data carrier, followed by transfer of the read identifying signs to a micro-controller in the game-playing device for their identification.

6. The method according to claim 1, wherein the step of authenticating the data carrier
30 includes reading operation or game identifying signs from the game-playing device, followed by comparing the identifying signs in the game-playing device with identifying signs in the data carrier.

7. The method as per any of Claims 3 to 6, wherein result of said step of comparing is

displayed via the game-playing device.

8. The method as per Claim 1, wherein the results of the operation or game are recorded into the data carrier.

5

9. The method as per any of Claims 3-6, wherein a list of operations is used as identifying signs.

10. The method as per Claim 1, wherein the step of authenticating includes verifying a secret access code stored in the data carrier.

10

11. The method as per Claim 1, wherein the step of authenticating includes running a verification program stored in the memory of the game-playing device.

15 12. The method as per Claim 1, wherein the step of authenticating includes reading a verification program from the data carrier and verifying the data carrier by the game-playing device by means of this program.

20 13. An electronic game-playing device associated with a data carrier and arranged to selectably run a non-game operation.

25 14. A system for playing a game comprising:
a stand-alone, portable electronic game-playing device capable of selectably performing a non-game playing operation; and
a data carrier for storing and/or recording data of a game or operation.

25

30 15. The system according to claim 14, wherein said game-playing device includes:
data carrier authentication tools;
a processing unit;
a display;
a data and command input block;
a micro-controller; and
a memory;
all coupled by buses.

30

16. The system according to claim 15, wherein said game-playing device further includes a data carrier reader connected with said buses.
- 5 17. The system as per Claim 16, wherein said data carrier reader is adapted to read identifying signs and operation and game programs on said data carrier.
18. The system as per Claim 16, wherein said reader is adapted to read a regional code from said data carrier.
- 10 19. The system as per any of Claims 16 to 18, wherein said reader is capable of recording data on said data carrier.
- 15 20. The system as per Claim 14, wherein said data carrier includes a microprocessor connected with an interface chain and memory units and equipped with an operation and/or game program.
21. The system as per Claim 20, wherein said data carrier further includes a data carrier verification program.
- 20 22. The system as per Claim 21, wherein said verification program includes a data carrier authentication subprogram.
- 25 23. The system as per any of Claims 14 to 22, wherein the data carrier comprises a smart debit card.
24. The system as per any of Claims 14 to 22, wherein the data carrier comprises a chip.
25. An electronic game-playing device comprising:
- 30 a processing unit capable of selectably running an operation or a game;
a data and command input block;
a display device;
data carrier authentication tools;
a micro-controller;

an operation and/or game identifying signs reader; and
a memory;
all connected by buses of the game-playing device.

5 26. The game-playing device as per Claim 25, wherein the operation and/or game identifying signs reader is capable of recording the information to the data carrier.

27. The game-playing device as per Claim 25, wherein said reader is connected to said data carrier authentication tools.

10

28. The game-playing device as per Claim 25, further comprising means for comparing regional codes in the game-playing device and the data carrier.

15 29. The game-playing device as per Claim 25, further comprising means for recording information from the game-playing device into the memory of the data carrier.

30. The game-playing device as per Claim 25, further comprising means for reading information stored in the data carrier.

20 31. The game-playing device as per Claim 25, further comprising means for reading the game program from the data carrier to the game-playing device.

