

**(12) STANDARD PATENT**  
**(19) AUSTRALIAN PATENT OFFICE**

(11) Application No. **AU 2003252012 B2**

(54) Title  
**Zoom lens system**

(51) International Patent Classification(s)  
**G02B 15/00** (2006.01)                      **G02B 15/173** (2006.01)  
**G02B 15/16** (2006.01)                      **G02B 27/64** (2006.01)

(21) Application No: **2003252012**                      (22) Date of Filing: **2003.07.18**

(87) WIPO No: **WO04/010199**

(30) Priority Data

(31) Number	(32) Date	(33) Country
<b>60/397,882</b>	<b>2002.07.22</b>	<b>US</b>

(43) Publication Date: **2004.02.09**

(43) Publication Journal Date: **2004.03.18**

(44) Accepted Journal Date: **2006.08.17**

(71) Applicant(s)  
**Panavision, Inc.**

(72) Inventor(s)  
**Caldwell, James Brian;Neil, Iain A.;Yamanashi, Takanori;Betensky, Ellis I.**

(74) Agent / Attorney  
**Spruson & Ferguson, Level 35 St Martins Tower 31 Market Street, Sydney, NSW, 2000**

(56) Related Art  
**US5835272**  
**US5771123**  
**US3192829**  
**US4971428**  
**US5790309**  
**US5721641**  
**US4033674**  
**US6157494**  
**US3970366**

(19) World Intellectual Property  
Organization  
International Bureau



(43) International Publication Date  
29 January 2004 (29.01.2004)

PCT

(10) International Publication Number  
WO 2004/010199 A2

- (51) International Patent Classification<sup>7</sup>: **G02B 15/00**
- (21) International Application Number:  
PCT/US2003/022418
- (22) International Filing Date: 18 July 2003 (18.07.2003)
- (25) Filing Language: English
- (26) Publication Language: English
- (30) Priority Data:  
60/397,882 22 July 2002 (22.07.2002) US
- (71) Applicant: **PANAVISION, INC.** [US/US]; 6219 DeSoto Avenue, Woodland Hills, CA 91367 (US).
- (72) Inventors: **BETENSKY, Ellis, I.**; 602-1465 Brenton Street, Halifax, Nova Scotia, B3J 3T3 (CA). **CALDWELL, James, Brian**; 1835 East Hallandale Beach Boulevard, Apt. 489, Hallandale Beach, FL 33009 (US). **NEIL, Iain, A.**; 4372 Park Vicente, Calabasas, CA 91302 (US). **YAMANASHI, Takanori**; 6333 Canoga Avenue, Woodland Hills, CA 91367 (US).
- (74) Agents: **KUBOTA, Glenn, M.** et al.; Morrison & Foerster LLP, Suite 3500, 555 West Fifth Street, Los Angeles, CA 90013-1024 (US).
- (81) Designated States (*national*): AE, AG, AL, AM, AT, AU, AZ, BA, BB, BG, BR, BY, BZ, CA, CH, CN, CO, CR, CU, CZ, DE, DK, DM, DZ, EC, EE, ES, FI, GB, GD, GE, GH, GM, HR, HU, ID, IL, IN, IS, JP, KE, KG, KP, KR, KZ, LC, LK, LR, LS, LT, LU, LV, MA, MD, MG, MK, MN, MW, MX, MZ, NI, NO, NZ, OM, PG, PH, PL, PT, RO, RU, SC, SD, SE, SG, SK, SL, SY, TJ, TM, TN, TR, TT, TZ, UA, UG, UZ, VC, VN, YU, ZA, ZM, ZW.
- (84) Designated States (*regional*): ARIPO patent (GH, GM, KE, LS, MW, MZ, SD, SL, SZ, TZ, UG, ZM, ZW), Eurasian patent (AM, AZ, BY, KG, KZ, MD, RU, TJ, TM), European patent (AT, BE, BG, CH, CY, CZ, DE, DK, EE, ES, FI, FR, GB, GR, HU, IE, IT, LU, MC, NL, PT, RO, SE, SI, SK, TR), OAPI patent (BF, BJ, CF, CG, CI, CM, GA, GN, GQ, GW, ML, MR, NE, SN, TD, TG).
- Published:**  
— *without international search report and to be republished upon receipt of that report*
- For two-letter codes and other abbreviations, refer to the "Guidance Notes on Codes and Abbreviations" appearing at the beginning of each regular issue of the PCT Gazette.*



WO 2004/010199 A2

(54) Title: ZOOM LENS SYSTEM

(57) Abstract: A zoom lens system is disclosed. The zoom lens system forms a final image of an object and a first intermediate real image between the object and the final image. The zoom lens system includes a first optical unit located between the object and the first intermediate real image. The first optical unit comprises at least one optical subunit which is moved to change the size (magnification) of the first intermediate real image. The zoom lens system also includes a second optical unit located between the first intermediate real image and the final image, at least a portion of which is moved to change the size (magnification) of the final image. The zoom lens system provides a wide zoom range of focal lengths with continuous zooming between the focal lengths and optional image stabilization.

## PATENT APPLICATION IN THE U.S. PATENT AND TRADEMARK OFFICE

for

**ZOOM LENS SYSTEM****Background of the Invention**

## 1. Field of the Invention

This invention relates to optical lens systems for cameras and other optical devices, and, in particular, to high performance zoom lens systems that produce a high quality  
5 image over a full zoom range of focal lengths and are capable of being provided with an extremely large zoom ratio.

## 2. Description of Related Art

**General Background of the Invention.** The use of zoom lens systems for all types of photography, such as broadcast television, high definition television ("HDTV"),  
10 advanced television ("ATV"), video camcorders, film cinematography and still photography has become increasingly popular. As the use of zoom lens systems has increased, the demand for wider ranges of zooming capability, i.e. large zoom ratios, has also increased. For example, the zoom lens systems used in broadcast television have steadily increased in zoom ratio capability over the years to a maximum of about 101 to 1 at present but there is a demand for a still larger  
15 zoom ratio. While the focal length range of a conventional zoom lens system may be increased by the use of a drop-in extender or other multiplier, such as a broadcast television zoom lens system with a focal length range of 8.9mm to 900mm being increased to 17.8mm to 1800mm to increase the telephoto capability, this does not change the zoom ratio of about 101 to 1. Moreover, for broadcast television zoom lens systems there are somewhat different requirements  
20 for "studio" (indoor) or "outside broadcast" (outdoor) use concerning the focal length range and acceptable "f" numbers, whereby it has become conventional practice to employ two different

zoom lens systems for indoor and outdoor broadcast television uses to maximize the capabilities for both types of uses.

Further, in addition to the demand and desirability of using zoom lens systems with wider ranges of focal lengths, such lenses must retain superior optical characteristics and performance that previously has been accomplished only by using separate objective lenses of different fixed focal lengths or zoom lens systems with a limited zoom ratio. As the zoom ratio increases, the difficulty in providing a high performance optical system with superior characteristics and performance also increases. Even most previously available zoom lens systems of a limited zoom range have one or more undesirable limitations such as the inability to focus adequately over the entire focal length range, the inability to focus on close objects, the lack of adequate optical performance over the entire focal length range and focus distance, the cost, the large size for the limited zoom range achieved and the like.

Still further, as the zoom range of a lens system increases, generally the length and weight increases whereby the difficulty in maintaining the lens and camera steady also increases. Therefore image stabilization also becomes an issue for the design of a practical zoom lens system having a large focal length range and zoom ratio.

Moreover, as the focal length range of a zoom lens system increases, generally the focusing problems also increase. Although close focusing at long focal lengths of the zoom range is not absolutely necessary, it is required at lesser focal lengths. In the past, continuous focusing over a considerable conjugate range from infinity to objects at a very short distance such as about 8 feet or less has been difficult to achieve. Further, the problem of "breathing" of the final image (where the perceived size changes as the focus distance is changed) at shorter focal lengths must be minimized to avoid, for example, one person disappearing from the scene as the focus is changed to another person at a different distance from the lens. These focus performance requirements, including maintaining the quality of the final image, tend to increase substantially the weight and cost of the zoom lens system unless the size can be minimized and performance maximized by the overall lens design, including glass selection.

**Background Information Concerning Zooming.** As discussed above, zoom lens systems with a wide-range of focal lengths are very desirable in numerous photographic applications, including broadcast television, cinematography and video and still photography. One standard zoom lens system used in these applications has a four-group PN(P or N)P

structure, where P stands for a group of at least one lens element wherein the lens group has positive power, N stands for a group of at least one lens element wherein the lens group has negative power, and the groups are identified consecutively from the object space toward the image space, as is conventional. The front positive group is often called the focusing group because it can be moved for focusing the zoom lens system at any focal length position without the need to refocus for any other focal length of the zoom lens. The second negative group is the variator, and it induces significant magnification change during zooming. The third group, which can in general have either positive or negative power, is the compensator, and it is movable to insure that the image plane remains stationary. It also can provide some of the magnification change to effect zooming. The final positive fourth group is often called the prime lens group because it forms a sharp image.

This basic zoom lens system is suitable for zoom ratios of 50:1 or even more. As the zoom ratio is extended to about 100:1, however, the variator is required to change its object magnification to such an extent during zooming that aberrations become impracticably large and difficult to correct. In addition, at such large zoom ratios there is a very large change in entrance pupil location during zooming, and this tends to make the front group very large and difficult to correct. Another problem derives from the fact that, to reduce the aberration change that results from a large change of magnification, it is desirable that the variator have reduced optical powers. Weaker optical power, however, also increases the lens travel and length of the optical system. For a narrow field-of-view this would not be a problem, but, for a wide field-of-view, large motions lead to an increase in the principal ray heights at the rear portion of the lens system. Since the requirements for either the front or the rear of the lens system can be satisfied, but not simultaneously, this results in no ideal place for the aperture stop. If the stop is placed near the front of the lens, the front lens element diameters, and resultant aberrations, are reduced, and if the aperture stop is placed nearer to the rear part of the lens system, the rear lens diameters and resultant aberrations are decreased.

US 3,970,366 discloses a highly variable magnification zoom lens system in which a first zoom lens is connected from an object side and then a second zoom lens is connected from behind said first zoom lens. Therein, a first diaphragm for determining the relative aperture of the total zoom lens system is provided between said first zoom lens and the second zoom lens.

It is therefore desirable to provide a zoom lens system with a wide zoom range of focal lengths and high performance characteristics for both indoor and outdoor use. It is further desirable to provide a zoom lens system with a ratio of about 300 to 1 and a zoom range, for example, from about 7mm to 2100mm focal length, with continuous zooming between the focal lengths. It is further desirable to provide a high performance zoom lens system with an optical system having a front zoom lens group for forming an intermediate image and a rear zoom lens group to magnify that image to thereby produce an extremely large zoom ratio. It is further desirable to provide such a zoom lens system with optical image stabilisation. It is further desirable to provide such a zoom lens system with a focusing lens group capable of precise focusing over the entire focal length range of the zoom ratio.

It is the object of the present invention to substantially overcome or at least ameliorate one or more of the disadvantages of the prior art.

15

#### SUMMARY OF THE INVENTION

Accordingly, the present invention provides a zoom lens system for forming a final image of an object, said system having an object side and an image side and forming a first intermediate real image between the object and the final image, said system characterised by, in order from the object side to the image side;

a first optical unit including at least two lens elements and located between the object and the first intermediate real image, said unit comprising at least one optical subunit which is moved to change the size (magnification) of the first intermediate real image; and

a second optical unit including at least two lens elements and located between the first intermediate real image and the final image, at least a portion of which is moved to change the size (magnification) of the final image.

The preferred embodiment of the invention provides a compound zoom lens system that consists of two separate zoom lens portions wherein the front zoom lens portion forms an intermediate image, and the rear zoom lens portion is a relay that transfers the intermediate image formed by the front zoom lens portion to the final image. The total zoom ratio of the complete compound zoom lens system is equal to the zoom ratio of the front zoom lens multiplied by the zoom ratio of the relay. Thus, if the zoom ratio of the front zoom lens portion is 20:1 and the zoom ratio of the relay is 15:1, then



employed in the system and some of the possible embodiments of the invention, with Figs. 1-3 illustrating a system having about a 300:1 zoom ratio, Figs. 4A and 4B having about a 130:1 zoom ratio and Figs. 5A and 5B having about a 13:1 zoom ratio in an ultra wide angle lens system;

5 Figs. 6A and 6B are optical diagrams of another embodiment of the zoom lens system of the present invention using three moving zoom lens groups, with the three zoom groups positioned for a short focal length in Fig. 6A and for a long focal length in Fig. 6B;

Figs. 7A and 7B are optical diagrams of another embodiment of the zoom lens system of the present invention using four moving zoom lens groups, with the four zoom groups  
10 positioned for a short focal length in Fig. 7A and for a long focal length in Fig. 7B;

Figs. 8A and 8B are optical diagrams of another embodiment of the zoom lens system of the present invention using four moving zoom lens groups, with the four zoom groups positioned for a short focal length in Fig. 8A and for a long focal length in Fig. 8B;

Figs. 9A and 9B are optical diagrams of another embodiment of the zoom lens  
15 system of the present invention using three moving zoom lens groups, with the three zoom groups positioned for a short focal length in Fig. 9A and for a long focal length in Fig. 9B;

Figs. 10-62 are figures that all relate to a single embodiment of the zoom lens system of the present invention that has a zoom ratio of about 300:1, with Fig. 10 being an optical diagram of the entire lens system, Figs. 11-30 comprising optical diagrams of the lens  
20 system in 20 different representative positions of the movable lens elements, Figs. 31-34 comprising optical diagrams of only the lens elements of the focus unit in four of the representative positions, Figs. 35 and 36 illustrating only the front two zoom lens groups in two of the representative positions, Figs. 37 and 38 illustrating only the rear zoom lens group in two of the representative positions, Figs. 39-58 comprising ray aberration diagrams for the same  
25 20 representative positions of all of the lens elements illustrated in Figs. 11-30, respectively, Fig. 59 comprising a graph of the focus cam movement relative to the focus distances from minimum (bottom) to infinity (top), Fig. 60 comprising graphs of the three zoom cam movements relative to the system focal lengths, Fig. 61 comprising a graph of the "f" numbers of the system at the final image relative to the system focal lengths, and Fig. 62 comprising a graph  
30 of the stop diameters relative to the system focal lengths;

Figs. 63 and 64 are an optical diagram and ray aberration graphs, respectively, for another embodiment of the zoom lens system of this invention incorporating a binary (diffractive) surface;

5 Figs. 65 and 66 are an optical diagram and ray aberration graphs, respectively, for still another embodiment of the zoom lens system of this invention incorporating a binary (diffractive) surface; and Figs. 67-70 are figures that relate to a still further embodiment of the invention having a zoom ratio of about 400:1 with Figs. 67 and 68 being optical diagrams at focal lengths of 7.47mm and 2983mm, respectively, and Figs. 69 and 70 being ray aberration graphs at focal lengths of 7.47mm and 2983mm, respectively;

10 Figs. 71 and 72A-72D are optical diagrams for an example of still another embodiment of the zoom lens system of this invention incorporating a mirror for folding the lens for added compactness, with Figs. 72A-72D showing the folded lens in a flat (unfolded) orientation for clarity, and illustrating various positions of the zoom groups;

Figs. 73A-73C are optical diagrams for an example of an infrared (IR)  
15 embodiment of the zoom lens system of this invention, illustrating various positions of the zoom groups; and Figs. 74-76 are ray aberration graphs corresponding to the position of the zoom groups shown in Figs. 73A-73C, respectively.

## DETAILED DESCRIPTION OF PREFERRED EMBODIMENTS

In the following description of preferred embodiments, reference is made to the  
20 accompanying drawings, which form a part hereof, and in which is shown by way of illustration specific embodiments in which the invention may be practiced. It is to be understood that other embodiments may be utilized and structural changes may be made without departing from the scope of the preferred embodiments of the present invention.

In accordance with its general aspects, the invention provides a zoom lens system  
25 for forming a final image of an object, said system forming a first intermediate real image between the object and the final image, said system comprising:

(a) a first optical unit (e.g., lens elements 8 through 15 in Figure 10) located between the object and the first intermediate real image, said unit comprising at least one optical subunit which is moved to change the size (magnification) of the first intermediate real image

(e.g., lens elements 8 through 11 are the primary source of magnification change for the first optical unit in Figure 10); and

(b) a second optical unit (e.g., lens elements 26 through 33 in Figure 10) located between the first intermediate real image and the final image at least a portion of which (e.g., one or more optical subunits or the entire second optical unit) is moved to change the size (magnification) of the final image (e.g., in Figure 10, lens elements 26 through 28 of the second optical unit are moved to change the size of the final image).

Preferably, the zoom lens system includes one or more optical subunits in either or both of the first and second optical units which is moved to hold the axial position of the final image substantially stationary as the focal length of the system is changed (e.g., lens elements 12 through 15 are the primary source of this function in Figure 10). Such a subunit, however, may not be needed in all cases, e.g., if the overall optical system has an axially movable sensor.

Preferably, in addition to the first and second optical units, the zoom lens system comprises a focus unit (e.g., lens elements 1 through 7 in Figure 10), a pupil imaging unit (e.g., lens elements 16 through 25 in Figure 10), and/or an image stabilization unit (e.g., lens elements 34 through 39 in Figure 10).

Preferably, the focus unit is (1) positioned in front of the first optical unit, (2) comprises two optical subunits that are movable along the zoom lens system's optical axis (e.g., lens element 2 and elements 3 and 4 in Figure 10), and/or (3) comprises seven or less lens elements.

Preferably, the image stabilization unit comprises (1) at least one lens element that is laterally movable off the system's optical axis (e.g., lens elements 34 through 36 in Figure 10), and/or (2) at least one lens element that is movable along the optical axis (e.g., lens elements 37 through 39 in Figure 10). The light passing through the system is preferably substantially collimated between said laterally and axially movable lens elements of the image stabilization unit.

In addition to the first intermediate real image, the zoom lens systems of the invention can form additional intermediate real images between the object and the final image. The systems can include additional optical units besides the first and second units for changing the sizes (magnifications) of those additional intermediate real images.

Preferably, the first intermediate real image is formed in an air space between the optical elements of the zoom lens system (e.g., the lens elements, prisms, folding mirrors or the like used in the system) and does not pass through any surface of an optical element during zooming. When more than one intermediate real image is formed, this is also preferably true for all of the intermediate images.

The first optical unit in combination with other units of the system can have the form of a conventional zoom lens. Similarly, the second optical unit in combination with other units of the system can have a conventional zoom lens form. The overall system can thus be viewed as a "compounding" of two conventional zoom lenses with, in accordance with the invention, control of pupil imaging between the compounded zoom lenses.

The overall system can also be viewed as a front zoom lens which forms an intermediate image and a relay system which receives the intermediate image and changes its magnification to form the final image.

These approaches for describing the zoom lens systems of the invention are used herein in the detailed discussions of various aspects of the invention. Although these approaches provide a convenient way of describing the invention, it is to be understood that the invention is not limited to these descriptions and various embodiments and applications of the invention may not be completely amenable to such descriptions.

In accordance with other aspects, the invention provides a zoom lens system for forming a final image of an object, said system having a range of focal lengths between a maximum focal length and a minimum focal length and forming at least a first intermediate real image between the object and the final image for all focal lengths within said range, said system comprising:

(a) a first lens unit having a focal length that is changed to change the size (magnification) of the first intermediate real image, said first lens unit being located between the object and the first intermediate real image for all focal lengths within said range; and

(b) a second lens unit for changing the size (magnification) of the final image, said second lens unit being located between the first intermediate real image and the final image for all focal lengths within said range.

In accordance with additional aspects, the invention provides a zoom lens system which comprises a variable focal length front lens unit which forms an intermediate real image

and a variable magnification rear lens unit which forms an image (preferably, a real image) of the intermediate image.

In accordance with further aspects, the invention provides a compound zoom lens system that collects radiation from an object space and delivers the radiation to a final image in image space, said system comprising multiple zoom lens portions including a first zoom lens portion forming an intermediate image of the radiation from the object space and a last zoom lens portion forming the final image in the image space.

In accordance with still further aspects, the invention provides a zoom lens system for forming a final image of an object, said system having an optical axis, a front lens surface, an aperture stop, and a chief ray which crosses the optical axis at the aperture stop, said system comprising first and second lens units that are moved to change the focal length of the system, wherein:

(a) between the front lens surface and the final image, the chief ray crosses the optical axis at at least one other location besides said aperture stop for all focal lengths of the system; and

(b) the system forms an intermediate real image that is located between the first and second lens units for all focal lengths of the system.

**Description of Some Zooming Principles and Systems of the Invention.** There are some unique aspects to a compound zoom lens system (i.e., a front zoom/zoom relay system) that enables an extraordinarily high degree of optical correction to be achieved. Imagine for a moment a simplified scenario in which the complete zooming motion takes place in stages. In the first stage the relay is initially set at a short focal length position that provides a small magnification of the intermediate image. The object conjugate of the relay will then have a small numerical aperture NA and its image conjugate will have a large numerical aperture NA. (As conventionally defined, the numerical aperture "NA" is equal to the sine of the vertex angle of the largest cone of meridional rays that can enter or leave an optical system or element, multiplied by the refractive index of the medium in which the vertex of the cone is located; and in the lens system optical prescriptions set forth below the "f" number equals the inverse of twice NA, i.e.  $f = 1 / 2 \times NA$ ). Since the NA in object space for the relay is equal to the NA in image space for the front zoom lens portion, then it is clear that in this first stage, the front zoom lens portion need only be well corrected for a small NA.

In the second stage, the front zoom lens portion is stationary at its long focal length position, and the relay then zooms to magnify the intermediate image to a greater and greater extent. As the focal length of the system increases during this second stage, the image NA of the relay becomes smaller and the object NA of the relay becomes larger. Hence, the image NA of the front zoom lens portion must also become larger. However, at the same time, the radial part of the intermediate image that is actually used becomes smaller and smaller as the system focal length gets larger.

Thus, the front zoom lens portion need not be corrected for a simultaneously large intermediate image size and a large relative aperture (NA). Rather, it needs to be corrected for a large intermediate image size at a small aperture, and for a small intermediate image size at a large aperture. This makes the design of the front zoom lens portion considerably easier than the design of a traditional zoom lens system having the same zoom ratio as the front zoom lens system of the present invention.

Likewise, the relay need only be corrected for a large image NA and large object size at the small magnification end of its focal lengths. At the other end of its zoom range of focal lengths, the object size is small and the image NA is also small.

As discussed above, in addition to a front zoom lens portion and a relay, the zoom lens systems of the invention preferably also include a pupil imaging unit. This unit serves to image the exit pupil of the front zoom lens portion into the entrance pupil of the relay. By selecting the appropriate powers, not only can the lens diameters, and attendant aberrations, of the relay be minimized, but control of the exit pupil position of the system can be improved.

As also discussed above, the intermediate image formed by the front zoom lens portion is preferably located at a position where it does not pass through any lens surfaces as the system is zoomed from its minimum to its maximum focal lengths. By being between the front zoom lens portion and the rear relay, the intermediate image is automatically behind the axially moving lens unit or units that provide zooming in the front zoom lens portion and in front of any axially moving lens units that provide zooming in the rear zoom portion. Since in certain embodiments of the invention the intermediate image can move during zooming, the locations for the lens surfaces on either side of the intermediate image, whether those surfaces are fixed or moving, are preferably chosen so that notwithstanding the motion of the intermediate image, the surfaces remain spaced from the intermediate image throughout the zoom range of the system.

Various of the foregoing features of the invention are illustrated in Figures 1-3 for a PNPP - PNPP compound zoom lens system with a zoom ratio of about 300:1. As indicated in Figure 1, this compound zoom lens system has a front zoom lens portion with a zoom ratio of about 20:1 and a rear zoom lens portion (relay) with a zoom ratio of about 15:1. The groups and their positive or negative power signs are also indicated in Figure 1. In this compound zoom lens system, the relay is stationary as the front zoom lens portion is operated from its shortest focal length position (shown in Figure 1) to its longest focal length position (shown in Figure 2). Once the front zoom lens portion reaches its long focal length position, the relay begins to vary the magnification of the intermediate image to further increase the focal length of the compound system. Figure 3 shows the system in its maximum focal length condition, in which the front zoom lens portion is at its maximum focal length position and the rear zoom (relay) lens portion is in its maximum magnification position.

Figures 1 and 2 show the small NA at the intermediate image plane and large NA at the final image plane that occurs during the initial phase of zooming from short to long. The size of the intermediate image is large during this phase, as shown in the figures. Figure 3 shows that the NA becomes larger at the intermediate image and smaller at the final image at the longest focal length position.

Note that in this example there are 8 zoom lens groups, but only 4 of them are independently movable for zooming. The 1st, 4th, 5th, and 8th groups are all stationary with respect to the final image. During focusing, however, one or more of these groups can be made to move.

The scenario sketched out here is for exemplary purposes. In practice, the zooming motion need not be clearly divided into two stages, and as a result the relay or a part of it can move during the initial zooming stages and not just near the long end of the focal lengths.

The example of Figs. 1-3 described above has a PNPP - PNPP construction in which the dash "-" signifies the end of the front zoom lens portion. Both the front zoom lens portion and rear zoom lens portion have variator and compensator zooming groups. One advantage of this configuration is that the intermediate image can be made absolutely stationary if desired. Rendering the image stationary will prevent it from passing through any optical surface that might reveal surface flaws and dust images that will appear at the final image. Using a four-group construction in the rear zoom lens portion also permits better control of the exit

pupil position, which may be important for matching the telecentricity requirements of certain image sensors.

If movement of the intermediate image can be tolerated, then it is possible to eliminate one of the compensators. Removal of the rear compensator is preferred in this case because it only moves when the beam diameters are relatively small. The resulting construction will then be a PNPP - PNP configuration.

For both of these configurations care must be taken to match the exit pupil of the front zoom lens portion with the entrance pupil of the relay. For this purpose, an eyepiece-like group is beneficial for converting the diverging beams emanating from the intermediate image into approximately parallel beams entering a normal PNP- or PNPP- type zoom lens system corrected for infinite conjugates.

One aspect of high-speed (large aperture) ultra-wide-range of focal lengths compound zoom lens systems of this type is that the intermediate image and all of its image faults are highly magnified by the zoom groups in the relay at the long focal length position. This places stringent requirements on the correction of secondary color aberrations in the front zoom lens portion and especially the focusing group. In order to accomplish this correction, it is necessary to use at least one, and more likely several, fluor-crown glass elements. As an alternative, calcium fluoride or binary (diffractive) surfaces could also be used for this purpose.

A variety of binary (diffractive) surfaces (diffractive elements) can be used in the practice of the invention. For example, for certain applications, one or more diffractive optical elements of the type disclosed in U.S. Patent No. 6,507,437, assigned to Canon, can be used, either alone or in combination with other approaches for correcting chromatic aberrations.

One big advantage of using a PNPP - PNPP or PNPP - PNP configuration over existing zoom lens systems is that both the front zoom lens portion and the rear zoom lens portion (relay) system can have very large zoom ratios. It is quite reasonable to have a zoom ratio of 20:1 or more for either the front zoom lens portion or the rear zoom lens portion in this case, so that a total zoom ratio of 400:1 or more is possible. However, if such a large zoom ratio is not required, it is possible to simplify the system significantly by instead using a relay with an NP configuration having two moving groups. Such a relay is very useful for large aperture applications with a total zoom ratio in the relay of about 3:1 to about 10:1. An example of a compound zoom lens system with a zoom ratio of about 130:1 having an about 20:1 zoom ratio

PNPP front zoom lens portion and an about 6.5:1 zoom ratio relay is shown in Figs. 4A and 4B. Fig. 4A illustrates the minimum focal length of about 7mm and Fig. 4B illustrates the maximum focal length of about 900mm. One disadvantage of this configuration is that the rearmost lens group is not stationary; hence it must be designed to withstand a considerable change of magnification at large apertures, which makes it somewhat difficult to design.

An even further simplified construction consisting of an NP front zoom lens portion and an NP rear zoom lens portion (relay) can also be designed, although the maximum zoom ratio in this case will be lowered. Clearly, the technique can be generalized to include a large number of combinations of various zoom lens arrangements for the front zoom lens portion and for the rear zoom lens portion. For example, a high zoom ratio, ultra wide angle zoom lens system can be constructed by using an NP, NPP or NPNP ultra wide angle front zoom lens portion having a zoom ratio of about 2:1 with an NP rear zoom lens portion (relay) having a zoom ratio of about 6.5:1. The result would be a compound zoom lens system with a zoom ratio of about 13:1 with a maximum full field of view of up to 100 degrees or more. Figs. 5A and 5B illustrate a 4.4mm-57.2mm,  $f/3$ - $f/7$  compound zoom lens system with a zoom ratio of about 13:1 for a 2/3" sensor. The full-field angle at the wide-angle end of this compound zoom lens system is more than 102 degrees. Clearly, a PNPP-type rear zoom lens portion (relay) similar to the one used in Figs. 1-3 could be used with this same ultra wide angle front zoom lens portion to yield an ultra wide angle compound zoom lens system with a zoom ratio of about 30:1.

The existence of an intermediate image is common to all of these configurations, and this offers some unique opportunities for aberration correction that are not typically available in zoom lens system types of the prior art. For example, aspheric surfaces placed on elements located near the intermediate image can have a strong impact on distortion and other field aberrations without disturbing the spherical aberration correction. Advantages of placing an aspheric surface in this area include that the tolerances are generous because the beam diameters are small, and the elements themselves are small. This means that the cost of using aspheric surfaces in this region is minimal.

**Detailed Description of the Preferred Embodiments.** As described above in the section entitled "Description of Some Zooming Principles and Systems of the Invention", each of the herein disclosed embodiments of the present invention includes a front zoom lens portion and a rear zoom lens portion thereby forming a compound zoom lens system. An

intermediate image is formed after the front zoom lens portion whereby the rear zoom lens portion functions as a zoom relay to magnify the intermediate image so as to produce the magnified final image for capturing by film or any other kind of light detector or capture device, such as a charge coupled device (CCD), in a camera. For purposes of this application, the term "camera" is used generically to describe any kind of light detecting or capturing device that may be placed after the lens system of the present invention, including a still, video or movie capture device, whether containing film, videotape, optical disk, CMOS, CCD or another storage medium, or an eyepiece or the human eye. Any such "camera" may include additional lens elements. At present it is contemplated that the front zoom lens portion will be comprised of two moving zoom lens groups and the rear zoom lens portion will be comprised of either one or two moving zoom lens groups, but it is to be understood that more or fewer moving zoom lens groups may be used without departing from the present invention. Also, at present it is contemplated that only one intermediate image will be formed in the entire compound zoom lens system but other embodiments of the present invention may form more than one intermediate image.

In addition to the front and rear zoom lens portions, the compound zoom lens system of the present invention preferably includes a focus lens group. It is preferred that the focus lens group be positioned at the front of the lens system, as shown by each of the embodiments disclosed herein, although it is possible to accomplish some and maybe all of the focusing elsewhere in the compound zoom lens system in other embodiments of the invention.

When a single intermediate image is formed in this compound zoom lens system, the final image is upside down and reversed left-to-right from the conventional orientation produced by an objective lens and therefore the image orientation must be accommodated by the camera. For a video camera using a single chip for the detector, it is possible to merely rotate the chip 180 degrees about the optical axis so that the chip reads the final image as though it is conventionally oriented. Another solution to the orientation problem for a video camera is to reverse the order in which the data is scanned, i.e. instead of from left-to-right and top-to-bottom the data can be read right-to-left and bottom-to-top to achieve the conventional orientation. Still another solution to the orientation problem for a video camera that uses a "frame store" feature to store an entire frame on a memory chip before it is transmitted for use is to merely transmit the stored frame from the frame store memory in the reverse order. For a movie film camera, the

entire camera with the film magazine may be turned upside down to, as a result, run the film upwardly for correcting the image orientation. Another solution for the orientation of the image in a movie film camera used in the conventional manner and employing the present zoom lens system is to use digital compositing wherein the film is digitally scanned and then, for example, after digital manipulation the image is imposed on new film in the conventional orientation. The use of a prism in or in connection with the lens system of this invention will also correct the orientation of the final image. For this approach, care must be taken so that the prism will not cause excessive deterioration of the quality of the final image, especially for high performance applications of the present lens system.

Due to the compound zoom arrangement of the zoom lens system of the present invention, the body of the compound lens system will often be of substantial length and therefore any deflection or vibration of the lens system relative to the camera may cause unacceptable deflection or vibration of the final image in the camera. Thus, at least for compound zoom lens systems of the present invention having large zoom ratios, long focal lengths and/or substantial length, it is contemplated that an image stabilization arrangement will be employed. While electronic image stabilization may be appropriate for some video camera applications, for higher performance zoom lens system applications it is preferred that an optical image stabilization arrangement be included in the body of the compound zoom lens system and preferably near the camera end of the lens system, such as is included in the embodiment of Figs. 10-62 described below.

Although it is more desirable to design and construct the compound zoom lens system of this invention as an integral unit for maximum performance, it is also possible to use two or more separable components to achieve the basic features. For example, a conventional zoom lens or a modified form thereof may be used as the front zoom lens portion and then the rear zoom lens portion may be comprised of a separate attachment that relays and varies the magnification of (e.g. zooms) the image formed by the front zoom lens portion, which image becomes the "intermediate" image, to form the final image. Thus, the front zoom lens portion will provide one zoom ratio and the rear attachment zoom portion will provide another zoom ratio. However, for such a combination, the pupil imaging should be controlled to obtain a final image of acceptable optical quality. Other such combinations of conventional and/or modified

lens portions may also be used to provide the compound zoom lens system of the present invention.

Figs. 6A through 9B illustrate optical diagrams for four different embodiments of the zoom lens system of the present invention. At the far right of each of the Figs. 6A-9B the two rectangular blocks represent the prism blocks for a conventional 3 CCD 2/3" detector, which is part of the video camera and therefore not part of the zoom lens system.

The following tables list the lens system optical prescriptions, the variable thickness positions for various surfaces, and the focal lengths and magnifications for various surface groups for each of those four embodiments. For simplicity and clarity in view of the large number of surfaces and the small scale of the optical diagrams that include all of the elements, only some of the surfaces in Figs. 6A through 9B that correspond to the surfaces set forth in the lens system optical prescriptions are identified. A more detailed explanation of the tables is provided following the tables.

## TABLES FOR FIGS. 6A &amp; 6B

## LENS SYSTEM OPTICAL PRESCRIPTION

Surface	Radius	Thickness	Glass Index	Glass Dispersion
OBJECT	Infinity	Infinity		
S1	925.010	10.000	1.90135	31.5
S2	280.601	20.595		
S3	626.503	19.748	1.49699	81.6
S4	-2050.828	0.300		
S5	-2871.294	12.027	1.49699	81.6
S6	-624.468	0.300		
S7	266.779	14.079	1.49699	81.6
S8	497.283	0.300		
S9	351.230	16.228	1.49699	81.6
S10	1246.212	0.300		
S11*	185.443	25.083	1.49699	81.6
S12	839.856	Variable		
S13	301.162	5.346	1.77249	49.6
S14*	71.693	15.360		
S15	-3690.461	2.000	1.77249	49.6
S16	100.162	27.480		
S17	-70.544	5.456	1.80400	46.6
S18	-3458.086	8.858	1.92286	18.9
S19	-125.683	Variable		
S20	-257.845	12.063	1.49699	81.6
S21	-78.411	0.127		
S22	149.706	13.001	1.49699	81.6
S23	-98.095	2.000	1.80349	30.4
S24	-266.962	0.100		
S25	114.669	6.712	1.49699	81.6
S26	485.498	Variable		
STOP	Infinity	24.165		
S28*	-41.960	2.000	1.60311	60.7
S29	40.078	31.156	1.69894	30.1
S30	83.406	12.225		
S31	-64.844	2.590	1.60311	60.7
S32	912.611	13.001	1.69894	30.1
S33	-52.224	24.076		
S34	99.845	2.313	1.49699	81.6
S35	167.386	15.000		
S36	155.608	14.122	1.49699	81.6
S37	-47.886	9.568	1.87399	35.3
S38	-67.571	0.018		
S39	381.504	2.000	1.87399	35.3
S40	49.653	11.590	1.43875	95.0
S41	-583.112	43.970		
S42*	50.132	14.235	1.43875	95.0
S43	482.784	Variable		
S44	-23.147	2.000	1.69100	54.8
S45*	32.021	1.889		
S46	52.655	21.412	1.84666	23.8
S47	-380.467	Variable		
S48	102.416	11.302	1.49699	81.6
S49	-50.958	0.405		
S50*	34.098	13.134	1.49699	81.6
S51	43.222	1.521		
S52	58.738	10.784	1.49699	81.6
S53	-35.052	2.000	1.74319	49.3
S54	43.422	1.334		
S55	57.389	10.079	1.49699	81.6
S56	-38.685	0.658		
S57	-35.272	3.772	1.78472	25.7
S58	-56.940	0.500		
S59	166.529	4.833	1.69100	54.8

S60	-100.192	0.250		
S61	83.273	5.608	1.69100	54.8
S62	808.144	Variable		
S63	Infinity	13.200	1.51680	64.1
S64	Infinity	2.000		
S65	Infinity	33.000	1.60859	46.4
S66	Infinity	5.000		
IMAGE	Infinity			

Note: Maximum image diameter = 11.0mm

\* Surface profiles of aspheric surfaces S11, S14, S28, S42, S45 and S50 are governed by the following conventional equation:

$$Z = \frac{(CURV)Y^2}{1+(1-(1+K)(CURV)^2Y^2)^{1/2}} + (A)Y^4 + (B)Y^6 + (C)Y^8 + (D)Y^{10}$$

where: CURV = 1/ (Radius of Surface)  
 Y = Aperture height, measured perpendicular to optical axis

K, A, B, C, D = Coefficients  
 Z = Position of surface profile for a given Y value, as measured along the optical axis from the pole (i.e. axial vertex) of the surface.

The coefficients for the surface S11 are:

K= -0.2197954  
 A= 9.0593667e-009  
 B= 1.7844857e-013  
 C= 1.5060271e-017  
 D= -9.7397917e-023

The coefficients for the surface S42 are:

K= -0.0460624  
 A= -2.6257869e-007  
 B= -2.5945471e-010  
 C= 2.4316558e-013  
 D= -1.2995378e-016

The coefficients for the surface S14 are:

K= 0.7048333  
 A= -3.0463508e-007  
 B= -1.1451797e-010  
 C= 3.4844023e-014  
 D= -2.2107339e-017

The coefficients for the surface S45 are:

K= 0.0  
 A= -1.1056187e-005  
 B= 2.8606310e-008  
 C= -1.2655154e-010  
 D= 2.2826095e-013

The coefficients for the surface S28 are:

K= -0.9252575  
 A= -1.8743376e-007  
 B= -1.0562170e-009  
 C= 2.8892387e-012  
 D= -3.6671423e-015

The coefficients for the surface S50 are:

K= 0.0  
 A= -1.8976230e-006  
 B= 1.2489903e-009  
 C= -2.3703340e-012  
 D= 3.0161146e-015

	VARIABLE THICKNESS POSITIONS AND DATA							
	P1	P2	P3	P4	P5	P6	P7	P8
EFL	7.257	9.008	16.013	36.022	82.023	174.970	399.652	900.099
F/No.	1.450	1.450	1.450	1.450	1.450	2.000	4.000	5.000
S12	1.000	23.202	72.004	118.539	150.121	162.578	162.380	162.474
S19	243.711	218.457	160.764	96.265	43.111	0.500	57.093	0.500
S26	1.000	4.080	12.979	30.924	52.631	82.760	26.357	82.523
S43	142.978	142.908	142.764	142.760	142.409	140.110	89.130	81.860
S47	8.255	8.273	8.377	8.434	8.540	4.765	3.198	5.165
S62	19.000	19.000	19.000	19.000	19.000	25.160	77.703	83.508

Surface Groups	Focal Lengths
S1 - S12	266.611
S13 - S19	-46.300
S20 - S26	91.566
S27 - S43	55.841
S44 - S47	-32.720
S48 - S62	42.594

## Surface Group Magnifications

Surfaces	P1 M'	P1 MP'	P2 M'	P2 MP'	P3 M'	P3 MP'	P4 M'	P4 MP'
S1 - S12	0.000	0.754	0.000	0.672	0.000	0.492	0.000	0.320
S13 - S19	-0.238	7.670	-0.268	7.215	-0.374	6.275	-0.599	5.828
S20 - S26	-0.350	0.876	-0.385	0.843	-0.495	0.746	-0.699	0.550
S27 - S43	0.871	-1.159	0.870	-1.159	0.854	-1.159	0.844	-1.159
S44 - S47	0.321	-2.846	0.322	-2.829	0.325	-2.794	0.327	-2.793
S48 - S62	-1.170	-0.304	-1.170	-0.305	-1.170	-0.308	-1.170	-0.308

Surfaces	P1 M'	P5 MP'	P6 M'	P6 MP'	P7 M'	P7 MP'	P8 M'	P8 MP'
S1 - S12	0.000	0.195	0.000	0.123	0.000	0.163	0.000	0.124
S13 - S19	-1.012	7.410	-1.390	-119.200	-1.382	4.682	-1.386	-141.400
S20 - S26	-0.945	0.312	-1.275	-0.017	-0.715	0.599	-1.279	-0.014
S27 - S43	0.834	-1.159	0.833	-1.159	0.774	-1.159	0.826	-1.159
S44 - S47	0.330	-2.712	0.338	-2.278	0.769	-0.501	0.856	-0.451
S48 - S62	-1.170	-0.313	-1.315	-0.361	-2.549	-0.731	-2.693	-0.727

Where, P1 M' is lens group magnification of lens group which equals (entrance marginal ray angle)/(exit marginal ray angle) and, P1 MP' is lens group magnification which equals entrance principal ray angle/exit principal ray angle and so on, upto P8 M' and P8 MP'; the first two characters representing position number, for example P1 M' and P1 MP' are for position 1.

## TABLES FOR FIGS. 7A &amp; 7B

## LENS SYSTEM OPTICAL PRESCRIPTION

Surface	Radius	Thickness	Glass Index	Glass Dispersion
OBJECT	Infinity	Infinity		
S1	1273.174	10.255	1.80099	35.0
S2	475.265	1.538		
S3	510.054	10.255	1.80099	35.0
S4	279.310	14.066		
S5	459.720	19.331	1.49699	81.6
S6	21434.630	0.308		
S7	800.941	10.451	1.49699	81.6
S8	27454.520	0.308		
S9	309.779	13.334	1.49699	81.6
S10	634.103	0.308		
S11	361.606	17.818	1.49699	81.6
S12	2023.306	0.308		
S13*	172.930	25.353	1.49699	81.6
S14	568.502	Variable		
S15	330.425	2.070	1.77249	49.6
S16*	73.838	18.829		
S17	726.741	2.051	1.77249	49.6
S18	102.189	25.577		
S19*	-73.683	6.352	1.77249	49.6
S20*	359.798	9.948	1.80809	22.8
S21	-116.821	Variable		
S22	-176.211	5.797	1.49699	81.6
S23	-69.609	0.003		
S24	144.415	20.317	1.49699	81.6
S25	-85.878	2.051	1.80349	30.4
S26	-282.651	0.000		
S27	85.718	6.142	1.49699	81.6
S28	157.754	Variable		
STOP	Infinity	22.498		
S30*	-34.201	2.051	1.60729	59.4
S31	42.409	2.743	1.69894	30.1
S32	101.162	4.085		
S33	-82.300	3.589	1.60311	60.7
S34	-90.892	3.444	1.69894	30.1
S35	-39.457	6.472		
S36	51.200	7.178	1.49699	81.6
S37	55.671	15.382		
S38	67.546	6.750	1.49699	81.6
S39	-47.804	3.076	1.87399	35.3
S40	-74.620	0.018		
S41	95.357	3.076	1.87399	35.3
S42	35.060	30.000	1.43875	95.0
S43	-130.232	68.459		
S44	Infinity	2.051		
S45	Infinity	2.051	1.77249	49.6
S46	-341.189	8.763		
S47*	-30.765	4.102	1.78469	26.3
S48	-36.525	21.109	1.51680	64.2
S49	-30.389	0.308		
S50	-160.796	14.522	1.51680	64.2
S51	-66.413	0.308		
S52	461.095	8.390	1.51680	64.2
S53	-109.832	7.208		
S54*	247.113	3.076	1.84666	23.8
S55	57.348	10.868	1.49699	81.6
S56	-56.360	0.289		
S57	-73.106	5.307	1.63853	55.4
S58	-44.690	Variable		
S59	-28.736	3.076	1.83400	37.2

S60	115.838	2.771		
S61	-31.347	2.871	1.83480	42.7
S62	-73.220	2.468		
S63	-57.858	7.254	1.84665	23.9
S64	-24.994	0.005		
S65	-29.067	2.871	1.80400	46.6
S66	-49.737	Variable		
S67	507.291	2.051	1.74319	49.3
S68	104.703	7.178	1.49699	81.6
S69	-76.662	Variable		
S70*	69.871	8.624	1.49699	81.6
S71	-663.734	8.908		
S72	-155.686	3.076	1.84665	23.9
S73	-1137.705	0.202		
S74	54.109	8.050	1.49699	81.6
S75	-73.493	0.393		
S76	-66.184	2.871	1.74319	49.3
S77	-99.535	19.484		
S78	Infinity	13.537	1.51633	64.1
S79	Infinity	2.051		
S80	Infinity	33.841	1.60859	46.4
S81	Infinity	5.019		
IMAGE	Infinity			

Note: Maximum image diameter = 11.0mm

\* Surface profiles of aspheric surfaces S13, S16, S19, S20, S30, S47, S54 and S70 are governed by the following conventional equation:

$$Z = \frac{(\text{CURV})Y^2}{1+(1-(1+K)(\text{CURV})^2Y^2)^{1/2}} + (A)Y^4 + (B)Y^6 + (C)Y^8 + (D)Y^{10} + (E)Y^{12} + (F)Y^{14} + (G)Y^{16}$$

where: CURV = 1/ (Radius of Surface)

Y = Aperture height, measured perpendicular to optical axis

K, A, B, C, D, E, F, G = Coefficients

Z = Position of surface profile for a given Y value, as measured along the optical axis from the pole (i.e. axial vertex) of the surface.

The coefficients for the surface S13 are:

K= -0.1600976  
 A= 6.9210418e-009  
 B= 2.2313210e-013  
 C= 1.1852054e-017  
 D= -2.0918949e-021  
 E= 2.2579263e-025  
 F= 8.1799420e-030  
 G= -1.2582071e-033

The coefficients for the surface S20 are:

K= 0.0  
 A= 3.4619978e-008  
 B= 4.2692157e-011  
 C= -7.0823340e-014  
 D= -2.3957687e-017  
 E= 5.4513203e-020  
 F= -1.4597367e-023  
 G= -4.1263059e-027

The coefficients for the surface S54 are:

K= 0.0  
 A= -2.743254e-006  
 B= -2.133804e-009  
 C= 1.668568e-011  
 D= -1.9544629e014  
 E= 0.0  
 F= 0.0  
 G= 0.0

The coefficients for the surface S16 are:

K= 0.9059289  
 A= -4.3564263e-007  
 B= -1.3760665e-010  
 C= 1.1349273e-014  
 D= -3.8588303e-017  
 E= 1.5211558e-020  
 F= -5.1726796e-025  
 G= -2.0900671e-027

The coefficients for the surface S30 are:

K= -0.8025959  
 A= -3.8556154e-007  
 B= -5.4410316e-010  
 C= 7.0427510e-012  
 D= -8.5740313e-015  
 E= -5.2635786e-017  
 F= 1.0608042e-019  
 G= 7.5783088e-023

The coefficients for the surface S70 are:

K= -2.3  
 A= 3.877213e-007  
 B= 4.916800e-010  
 C= -1.461192e-012  
 D= -3.258352e-017  
 E= 4.664784e-018  
 F= -4.216175e-021  
 G= 0.0

The coefficients for the surface S19 are:

K= 0.0  
 A= -6.5866466e-008  
 B= -3.2305127e-011  
 C= -3.5095033e-014  
 D= 4.0315700e-017  
 E= -6.1913043e-021  
 F= -2.4403843e-023  
 G= 9.0865109e-027

The coefficients for the surface S47 are:

K= 0.0  
 A= -1.2184510e-005  
 B= 1.2115245e-007  
 C= -3.0828524e-010  
 D= -5.7252449e-014  
 E= 0.0  
 F= 0.0  
 G= 0.0

VARIABLE THICKNESS POSITIONS AND DATA							
	P1	P2	P3	P4	P5	P6	P7
EFL	7.257	12.152	35.981	82.040	145.068	736.934	2088.142
F/No.	1.450	1.450	1.450	1.450	1.450	7.200	12.500
S14	1.026	51.867	122.026	160.824	167.824	157.900	167.823
S21	262.564	202.199	103.948	49.493	0.000	34.351	0.000
S28	1.563	11.088	39.178	55.576	97.329	72.903	97.329
S58	8.616	8.616	8.616	8.616	8.616	99.467	105.316
S66	111.358	111.358	111.358	111.358	111.358	53.699	0.000
S69	38.387	38.387	38.387	38.387	38.387	5.195	53.100

Surface Groups	Focal Lengths
S1 - S14	283.564
S15 - S21	-52.598
S22 - S28	102.619
S29 - S58	51.668
S59 - S66	-29.319
S67 - S69	178.034
S70 - S77	70.650

Surface Group Magnifications

Surfaces	P1 M'	P1 MP'	P2 M'	P2 MP'	P3 M'	P3 MP'	P4 M'	P4 MP'
S1 - S14	0.000	0.740	0.000	0.564	0.000	0.318	0.000	0.179
S15 - S21	-0.260	7.365	-0.347	6.511	-0.644	6.193	-1.207	7.342
S22 - S28	-0.369	0.833	-0.462	0.740	-0.736	0.466	-0.896	0.306
S29 - S58	-2.392	-0.356	-2.392	-0.356	-2.392	-0.356	-2.392	-0.356
S59 - S66	-0.282	25.995	-0.282	25.995	-0.282	25.993	-0.282	25.994
S67 - S69	14680.000	0.231	14680.000	0.231	14680.000	0.231	14680.000	0.231
S70 - S77	0.000	0.447	0.000	0.447	0.000	0.447	0.000	0.447

Surfaces	P5 M'	P5 MP'	P6 M'	P6 MP'	P7 M'	P7 MP'
S1 - S14	0.000	0.117	0.000	0.174	0.000	0.117
S15 - S21	-1.468	-19.350	-1.150	14.886	-1.468	-19.350
S22 - S28	-1.303	-0.101	-1.065	0.137	-1.303	-0.101
S29 - S58	-2.392	-0.356	-2.392	-0.356	-2.392	-0.356
S59 - S66	-0.282	25.994	-2.227	0.319	-4.006	0.300
S67 - S69	14680.000	0.231	271.410	2.365	81.569	1.386
S70 - S77	0.000	0.447	-0.001	-0.374	-0.005	-1.131

Where, P1 M' is lens group magnification of lens group which equals (entrance marginal ray angle)/(exit marginal ray angle) and, P1 MP' is lens group magnification which equals entrance principal ray angle/exit principal ray angle and so on, upto P7 M' and P7 MP'; the first two characters representing position number, for example P1 M' and P1 MP' are for position 1.

## TABLES FOR FIGS. 8A &amp; 8B

## LENS SYSTEM OPTICAL PRESCRIPTION

Surface	Radius	Thickness	Glass Index	Glass Dispersion
OBJECT	Infinity	Infinity		
S1	-763.589	10.000	1.80099	35.0
S2	408.783	15.991		
S3	1218.452	22.500	1.49699	81.6
S4	-948.218	0.100		
S5	4440.119	19.600	1.49699	81.6
S6	-478.965	0.100		
S7	355.717	24.300	1.49699	81.6
S8	-1197.673	0.100		
S9	168.455	28.500	1.49699	81.6
S10	686.627	Variable		
S11	240.261	2.650	1.77249	49.6
S12*	58.196	12.668		
S13	307.706	2.900	1.77249	49.6
S14	100.924	19.233		
S15	-70.095	3.050	1.77249	49.6
S16	236.075	14.100	1.84666	23.8
S17	-126.479	Variable		
S18	-420.335	9.200	1.49699	81.6
S19	-81.355	0.126		
S20	155.733	15.650	1.49699	81.6
S21	-98.523	2.750	1.80099	35.0
S22	-285.204	10.687		
S23	76.070	7.900	1.49699	81.6
S24	118.043	Variable		
STOP	Infinity	6.800		
S26*	-35.243	6.500	1.60674	45.1
S27	55.360	0.106		
S28	55.900	4.050	1.75519	27.5
S29	155.439	4.934		
S30	-63.039	5.050	1.80518	25.4
S31	-39.609	2.240		
S32	56.818	10.900	1.45599	90.3
S33	-43.388	2.150	1.80099	35.0
S34	-61.503	2.158		
S35	107.501	2.100	1.80099	35.0
S36	29.896	11.600	1.49699	81.6
S37	166.103	78.890		
S38	59.002	9.670	1.83741	25.4
S39	-405.826	20.924		
S40	-22.134	19.750	1.80099	35.0
S41	-33.299	5.803		
S42	-129.563	12.646	1.49699	81.6
S43	-52.914	0.152		
S44	59.828	5.419	1.49699	81.6
S45	-209.080	0.100		
S46	37.693	6.143	1.74099	52.7
S47	177.702	Variable		
S48	-106.846	1.600	1.83480	42.7
S49	21.576	6.448		
S50	-27.697	6.650	1.80099	35.0
S51	7367.260	0.829		
S52	129.249	5.126	1.84583	24.0
S53	-46.358	Variable		
S54	538.505	1.500	1.80099	35.0
S55	95.344	11.395	1.60300	65.5
S56	-60.650	Variable		
S57	87.009	5.185	1.48749	70.2
S58	-165.647	1.434		
S59	-85.357	1.500	1.80518	25.4

S60	-1236.715	0.100		
S61	50.007	7.563	1.69472	54.5
S62	549.061	18.000		
S63	Infinity	13.537	1.51633	64.1
S64	Infinity	2.051		
S65	Infinity	33.841	1.60859	46.4
S66	Infinity	Variable		
IMAGE	Infinity			

Note: Maximum image diameter = 11.0mm

\* Surface profiles of aspheric surfaces S12 and S26 are governed by the following conventional equation:

$$Z = \frac{(\text{CURV})Y^2}{1+(1-(1+K)(\text{CURV})^2Y^2)^{1/2}} + (A)Y^4 + (B)Y^6 + (C)Y^8 + (D)Y^{10}$$

where: CURV = 1/ (Radius of Surface)  
 Y = Aperture height, measured perpendicular to optical axis

K, A, B, C, D = Coefficients  
 Z = Position of surface profile for a given Y value, as measured along the optical axis from the pole (i.e. axial vertex) of the surface.

The coefficients for the surface S12 are:

- K= 0.0
- A= -1.3820532e-007
- B= -2.7133115e-011
- C= -9.2535195e-015
- D= 3.3313103e-018

The coefficients for the surface S26 are:

- K= -0.5520119
- A= -1.0148386e-006
- B= -5.9646048e-011
- C= -1.3030573e-013
- D= 3.2918363e-016

VARIABLE THICKNESS POSITIONS AND DATA							
	P1	P2	P3	P4	P5	P6	P7
EFL	7.274	12.145	36.011	82.004	144.947	738.776	2095.406
F/No.	1.450	1.450	1.450	1.450	1.450	9.400	14.100
S10	3.154	50.878	126.861	163.460	167.963	167.403	168.654
S17	271.009	213.056	113.646	61.255	10.607	68.828	3.277
S24	2.350	12.345	35.982	51.876	97.922	40.276	104.616
S47	4.633	5.482	4.658	5.264	6.015	53.226	73.878
S53	105.364	104.868	105.482	104.798	103.775	14.725	2.050
S56	1.550	1.550	1.550	1.550	1.550	43.752	35.462
S66	4.969	4.799	4.853	4.815	5.202	4.818	5.114

Surface Groups	Focal Lengths
S1 - S10	262.599
S11 - S17	-50.895
S18 - S24	98.756
S25 - S47	37.686
S48 - S53	-25.559
S54 - S56	106.555
S57 - S62	81.336

## Surface Group Magnifications

Surfaces	P1 M'	P1 MP'	P2 M'	P2 MP'	P3 M'	P3 MP'	P4 M'	P4 MP'
S1 - S10	0.000	0.805	0.000	0.626	0.000	0.337	0.000	0.191
S11 - S17	-0.248	7.962	-0.323	7.245	-0.625	7.155	-1.136	9.531
S18 - S24	-0.349	0.734	-0.431	0.633	-0.680	0.394	-0.831	0.233
S25 - S47	-1.752	-0.293	-1.612	-0.293	-1.683	-0.293	-1.613	-0.293
S48 - S53	-0.505	5.934	-0.574	4.957	-0.532	5.900	-0.571	5.176
S54 - S56	-1.558	1.108	-1.529	1.487	-1.539	1.120	-1.533	1.378
S57 - S62	0.233	1.240	0.235	3.217	0.234	1.263	0.234	2.205

Surfaces	P5 M'	P5 MP'	P6 M'	P6 MP'	P7 M'	P7 MP'
S1 - S10	0.000	0.130	0.000	0.184	0.000	0.120
S11 - S17	-1.263	-8.111	-1.246	6.886	-1.285	-6.384
S18 - S24	-1.324	-0.233	-0.748	0.350	-1.444	-0.301
S25 - S47	-1.813	-0.293	-1.890	-0.293	-2.412	-0.293
S48 - S53	-0.496	4.492	-3.524	0.483	-4.060	0.347
S54 - S56	-1.600	1.750	-1.939	2.244	-1.904	1.880
S57 - S62	0.230	-29.370	0.234	-0.833	0.231	-1.610

Where, P1 M' is lens group magnification of lens group which equals (entrance marginal ray angle)/(exit marginal ray angle) and, P1 MP' is lens group magnification which equals entrance principal ray angle/exit principal ray angle and so on, upto P7 M' and P7 MP'; the first two characters representing position number, for example P1 M' and P1 MP' are for position 1.

TABLES FOR FIGS. 9A & 9B  
LENS SYSTEM OPTICAL PRESCRIPTION

Surface	Radius	Thickness	Glass Index	Glass Dispersion
OBJECT	Infinity	Variable		
S1	Infinity	50.000		
S2	-621.758	5.169	1.69350	53.2
S3	457.301	Variable		
S4	-2452.883	4.799	1.80518	25.4
S5	599.599	Variable		
S6	911.220	25.082	1.45599	90.3
S7	-497.020	0.100		
S8	-2000.000	0.000		
S9	1000.000	0.000		
S10	2062.549	12.736	1.49699	81.6
S11	-1165.481	Variable		
S12	963.440	19.740	1.49699	81.6
S13	-560.694	0.200		
S14	382.994	19.312	1.49699	81.6
S15	-17187.180	0.200		
S16	191.959	26.185	1.43875	95.0
S17	702.850	0.000		
S18	324.818	Variable		
S19	130.133	3.120	1.77249	49.6
S20*	40.551	15.089		
S21	87.300	2.500	1.77249	49.6
S22	70.260	14.709		
S23	-76.831	2.730	1.77249	49.6
S24	108.868	11.313	1.84666	23.8
S25	-166.114	Variable		
S26	2466.515	12.326	1.49699	81.6
S27	-72.273	0.200		
S28	114.639	17.864	1.49699	81.6
S29	-80.007	3.100	1.80099	35.0
S30	-402.245	0.200		
S31	56.927	6.364	1.48749	70.2
S32	83.100	Variable		
STOP	Infinity	6.855		
S34*	-32.543	2.000	1.60311	60.7
S35	-178.894	11.407		
S36	-41.737	3.274	1.84666	23.8
S37	-32.963	0.200		
S38	49.510	12.747	1.49699	81.6
S39	-39.721	2.400	1.80099	35.0
S40	-53.729	0.200		
S41	-163.422	1.850	1.80439	39.6
S42	26.111	9.221	1.49699	81.6
S43	-156.748	58.646		
S44	44.245	2.533	1.80439	39.6
S45	1686.200	39.233		
S46	-21.116	6.938	1.77249	49.6
S47	-21.969	14.095		
S48	92.954	2.220	1.60300	65.5
S49	-59.449	0.200		
S50	20.331	2.228	1.62229	53.2
S51	47.914	Variable		
S52	-116.378	0.950	1.83480	42.7
S53	34.369	3.756		
S54	-16.771	0.950	1.81600	46.6
S55	-36.990	1.142		
S56	-21.552	17.886	1.78469	26.3
S57	-26.412	Variable		
S58	-293.612	4.856	1.60311	60.7
S59	-78.391	0.200		

S60	272.204	5.642	1.49699	81.6
S61	-126.344	0.200		
S62	124.541	7.681	1.49699	81.6
S63	-102.092	2.500	1.80518	25.4
S64	-874.268	0.200		
S65	400.000	0.000		
S66	38.596	8.430	1.45599	90.3
S67	211.910	6.207		
S68	Infinity	0.500		
S69	123.725	2.000	1.81600	46.6
S70	39.478	7.176		
S71	-84.356	2.000	1.74099	52.7
S72	36.196	18.326	1.84666	23.8
S73	210.724	0.984		
S74	Infinity	7.645		
S75	105.952	3.999	1.49699	81.6
S76	-91.250	0.200		
S77	46.317	5.948	1.60300	65.5
S78	-69.543	1.500	1.84666	23.8
S79	166.511	22.000		
S80	Infinity	13.200	1.51633	64.1
S81	Infinity	2.000		
S82	Infinity	33.000	1.60859	46.4
S83	Infinity	0.000		
S84	Infinity	0.000		
IMAGE	Infinity			

Note: Maximum image diameter = 11.0mm

\* Surface profiles of aspheric surfaces S20 and S34 are governed by the following conventional equation:

$$Z = \frac{(\text{CURV})Y^2}{1+(1 - (1+K)(\text{CURV})^2Y^2)^{1/2}} + (A)Y^4 + (B)Y^6 + (C)Y^8 + (D)Y^{10}$$

where: CURV = 1/ (Radius of Surface)

Y = Aperture height, measured perpendicular to optical axis

K, A, B, C, D = Coefficients

Z = Position of surface profile for a given Y value, as measured along the optical axis from the pole (i.e. axial vertex) of the surface.

The coefficients for the surface S20 are:

K= -0.3254663  
 A= -3.65160e-007  
 B= -1.14704e-010  
 C= -5.60564e-014  
 D= -5.86283e-018

The coefficients for the surface S34 are:

K= 0.348034  
 A= 1.350560e-006  
 B= 2.453070e-009  
 C= -2.820340e-012  
 D= 4.745430e-015

VARIABLE THICKNESS POSITIONS AND DATA						
	P1	P2	P3	P4	P5	P6
EFL	7.278	7.278	7.278	8.817	12.199	18.641
F/No.	1.749	1.749	1.749	1.749	1.749	1.749
SO	Infinity	5322.600	2499.900	Infinity	Infinity	Infinity
S3	17.233	50.424	82.285	17.233	17.233	17.233
S5	3.856	8.913	13.211	3.856	3.856	3.856
S11	74.605	36.357	0.200	74.605	74.605	74.605
S18	0.200	0.200	0.200	26.070	64.733	106.272
S25	300.191	300.191	300.191	272.377	230.274	183.410
S32	1.334	1.334	1.334	3.266	6.708	12.035
S51	1.647	1.647	1.647	1.647	1.647	1.647
S57	80.778	80.778	80.778	80.778	80.778	80.778

VARIABLE THICKNESS POSITIONS AND DATA						
	P7	P8	P9	P10	P11	P12
EFL	32.734	60.449	94.190	123.985	206.250	284.791
F/No.	1.749	1.749	1.890	2.020	2.160	2.700
SO	Infinity	Infinity	Infinity	Infinity	Infinity	Infinity
S3	17.233	17.233	17.233	17.233	17.233	17.233
S5	3.856	3.856	3.856	3.856	3.856	3.856
S11	74.605	74.605	74.605	74.605	74.605	74.605
S18	148.849	183.007	201.036	209.783	216.511	215.851
S25	132.062	85.948	57.616	42.322	21.856	15.570
S32	20.806	32.763	43.065	49.609	63.170	70.310
S51	1.647	1.647	2.130	3.050	8.806	15.438
S57	80.778	80.778	80.294	79.375	73.618	66.987

VARIABLE THICKNESS POSITIONS AND DATA					
	P13	P14	P15	P16	P17
EFL	717.193	2092.160	2092.160	2092.160	2092.160
F/No.	5.200	13.750	13.750	13.750	17.490
SO	Infinity	Infinity	8708.000	4050.000	2499.900
S3	17.233	17.233	37.759	59.403	82.285
S5	3.856	3.856	7.178	10.305	13.211
S11	74.605	74.605	50.757	25.988	0.200
S18	211.275	208.261	208.261	208.261	208.261
S25	5.736	0.200	0.200	0.200	0.200
S32	84.680	93.262	93.262	93.262	93.262
S51	39.946	82.225	82.225	82.225	82.225
S57	42.480	0.200	0.200	0.200	0.200

Surface Groups	Focal Lengths
S2 - S3	-379.209
S4 - S5	-597.975
S6 - S11	484.131
S12 - S18	229.394
S2 - S18	262.190
S19 - S25	-49.050
S26 - S32	79.931
S33 - S51	41.254
S52 - S57	-26.810
S58 - S79	70.920

Surface Group Magnifications

Surfaces	P1 M'	P1 MP'	P2 M'	P2 MP'	P3 M'	P3 MP'	P4 M'	P4 MP'
S2 - S3	0.000	1.732	0.066	1.710	0.129	1.696	0.000	1.971
S4 - S5	0.599	1.754	0.594	1.563	0.59	1.425	0.599	2.388
S6 - S11	2.150	0.529	2.229	0.608	2.304	0.682	2.150	0.374
S12 - S18	-0.537	0.642	-0.537	0.642	-0.537	0.642	-0.537	0.53
S2 - S18	0.000	1.030	-0.047	1.043	-0.094	1.058	0.000	0.934
S19 - S25	-0.185	8.447	-0.185	8.447	-0.185	8.447	-0.206	7.952
S26 - S32	-0.252	0.756	-0.252	0.756	-0.252	0.756	-0.252	0.731
S33 - S51	-1.446	-0.378	-1.446	-0.378	-1.446	-0.378	-1.442	-0.378
S52 - S57	-0.673	6.392	-0.673	6.392	-0.673	6.392	-0.676	6.392
S58 - S79	-0.611	0.966	-0.611	0.966	-0.611	0.966	-0.611	0.966

Surfaces	P5 M'	P5 MP'	P6 M'	P6 MP'	P37 M'	P7 MP'	P8 M'	P8 MP'
S2 - S3	0.000	2.695	0.000	6.440	0.000	-4.655	0.000	-1.279
S4 - S5	0.599	-24.64	0.599	-0.414	0.599	0.216	0.599	0.403
S6 - S11	2.150	-0.033	2.150	-1.271	2.150	-127.8	2.150	4.484
S12 - S18	-0.537	0.365	-0.537	0.187	-0.537	0.004	-0.537	-0.147
S2 - S18	0.000	0.788	0.000	0.633	0.000	0.473	0.000	0.341
S19 - S25	-0.245	7.233	-0.31	6.531	-0.424	6.046	-0.601	6.421
S26 - S32	-0.319	0.688	-0.386	0.622	-0.496	0.512	-0.646	0.362
S33 - S51	-1.445	-0.378	-1.448	-0.378	-1.448	-0.378	-1.449	-0.378
S52 - S57	-0.673	6.392	-0.671	6.392	-0.671	6.392	-0.67	6.392
S58 - S79	-0.611	0.966	-0.612	0.966	-0.612	0.966	-0.612	0.966

Surfaces	P9 M'	P9 MP'	P10 M'	P10MP'	P11 M'	P11MP'	P12 M'	P12MP'
S2 - S3	0.000	-0.736	0.000	-0.549	0.000	-0.387	0.000	-0.365
S4 - S5	0.599	0.468	0.599	0.496	0.599	0.522	0.599	0.526
S6 - S11	2.150	3.296	2.150	2.964	2.150	2.701	2.150	2.668
S12 - S18	-0.537	-0.234	-0.537	-0.279	-0.537	-0.330	-0.537	-0.338
S2 - S18	0.000	0.265	0.000	0.225	0.000	0.180	0.000	0.173
S19 - S25	-0.771	8.327	-0.894	11.79	-0.983	-18.95	-1.004	-14.68
S26 - S32	-0.770	0.233	-0.846	0.152	-1.064	-0.084	-1.092	-0.107
S33 - S51	-1.431	-0.378	-1.406	-0.378	-1.344	-0.378	-1.359	-0.378
S52 - S57	-0.692	5.731	-0.728	4.790	-0.916	2.531	-1.194	1.491
S58 - S79	-0.611	1.263	-0.611	2.227	-0.611	-2.992	-0.610	-1.604

Surfaces	P13M'	P13MP'	P14M'	P14MP'	P15M'	P15MP'	P16M'	P16MP'
S2 - S3	0.000	-0.351	0.000	-0.348	0.041	-0.294	0.085	-0.24
S4 - S5	0.599	0.529	0.599	0.529	0.596	0.529	0.593	0.529
S6 - S11	2.150	2.646	2.150	2.642	2.199	2.691	2.250	2.742
S12 - S18	-0.537	-0.344	-0.537	-0.345	-0.537	-0.345	-0.537	-0.345
S2 - S18	0.000	0.169	0.000	0.168	-0.029	0.145	-0.061	0.12
S19 - S25	-0.919	-5.386	-0.870	-3.955	-0.869	-3.955	-0.869	-3.955
S26 - S32	-1.351	-0.287	-1.561	-0.395	-1.561	-0.395	-1.561	-0.395
S33 - S51	-1.719	-0.378	-2.606	-0.378	-2.61	-0.378	-2.612	-0.378
S52 - S57	-2.093	0.631	-3.758	0.316	-3.685	0.316	-3.626	0.316
S58 - S79	-0.613	-1.659	-0.600	-7.955	-0.610	-7.955	-0.619	-7.955

Surfaces	P17M'	P17MP'
S2 - S3	0.129	-0.183
S4 - S5	0.590	0.528
S6 - S11	2.304	2.795
S12 - S18	-0.537	-0.345
S2 - S18	-0.094	0.093
S19 - S25	-0.869	-3.955
S26 - S32	-1.561	-0.395
S33 - S51	-2.612	-0.378
S52 - S57	-3.629	0.316
S58 - S79	-0.618	-7.955

Where, P1 M' is lens group magnification of lens group which equals (entrance marginal ray angle)/(exit marginal ray angle) and, P1 MP' is lens group magnification which equals entrance principal ray angle/exit principal ray angle and so on, upto P17 M' and P17 MP'; the first two characters representing position number, for example P1 M' and P1 MP' are for position 1.

The group of elements defined by surfaces 69 through 73 is translated in a direction perpendicular to the optical axis to compensate for image vibration

In the lens system optical prescriptions provided above for each of the four embodiments, each surface of a lens element identified in the left hand column ("Surface"), the radius of that surface in the second column ("Radius"), the thickness on the optical axis between that surface and the next surface, whether glass or air, in the third column ("Thickness"), the refractive indices of the glass lens elements set forth in the fourth column ("Glass Index"), and the dispersion values for the lens elements ("Glass Dispersion") set forth in the fifth column. The surface numbers in the first column "Surface" represent the surfaces numbered from left-to-right in the Figs. in the conventional manner, namely from object space to image space.

In the left hand or "Surface" column of each lens system optical prescription provided above, the object to be imaged (e.g., photographed) is identified as "OBJECT", the adjustable iris or stop is identified as "STOP", and the final image is identified as "IMAGE". The adjustable spaces between lens elements, such as on either side of movable zoom groups, are identified as "Variable" in the third or Thickness column of the lens system optical prescription. The EFL, Radius and Thickness dimensions are given in millimeters with the Thickness being the distance after that surface on the optical axis. When two surfaces of adjacent elements have the same radius and are coincident, as in a doublet or triplet, only one surface is identified in the first or "Surf" column.

For each of the four embodiments, Aspheric Coefficients for each of the aspheric surfaces are provided following the table of optical prescriptions.

In addition, for each of the four embodiments, tables of the variable thickness positions for various surfaces in each lens system optical prescription are provided which identify positions in the format "Px" for various surfaces (corresponding to entries in the Surface column of the optical prescription tables). The effective focal length (EFL) and the "f" number (F/No.) are also provided for each position.

Now each of the four embodiments of Figs. 6A-9B will be described briefly to identify some of their differences. The embodiment of Figs. 6A and 6B has an effective focal length range of about 7.25mm to 900mm, which provides a zoom ratio of about 125:1, while using three movable zoom lens groups, namely, Zoom 1, Zoom 2, and Zoom 3, with a focus lens group Focus at the object space end of the lens. The Zoom 3 group actually is comprised of two groups of elements that have a small amount of movement between surfaces S47 and S48 (compare Figs. 6A and 6B). The embodiment of Figs. 7A and 7B has an effective focal length

range of about 7.27mm to 2088mm, which provides a zoom ratio of about 287:1, with four movable zoom lens groups (Zoom 1, 2, 3 and 4) and a focus lens group. The embodiment of Figs. 8A and 8B has an effective focal length range of about 7.27mm to 2095mm, which also provides a zoom range of about 287:1, with four moving zoom lens groups and a focus lens group, which is very similar to the performance of the lens embodiment of Figs. 7A and 7B. Similarly, the embodiment of Figs. 9A and 9B has an effective focal length range of about 7.27mm to 2092mm, which also provides a zoom ratio of about 287:1, but uses only three moving zoom lens groups. Each of these four embodiments includes plural aspheric surfaces with the embodiments of the Figs. 8A-8B and 9A-9B having only two such surfaces while the embodiment of Figs. 7A-7B includes eight such surfaces, as indicated in the lens system optical prescriptions. The embodiment of Figs. 9A and 9B also includes optical image stabilization lens elements near the camera end of the lens system similar to those included in the embodiment of Figs. 10-62, which will be described below.

**Detailed Description of the Embodiment of Figs. 10-62.** As noted above in the section entitled "Brief Description of the Drawings," Figs. 10-62 all relate to a single embodiment of the present invention that is directly and immediately applicable to the broadcast television market, although other markets are also available and various other embodiments and modifications of the invention may be more applicable to other markets. This embodiment of the compound zoom lens system of this invention has a zoom range of approximately 7 mm to 2100 mm in focal length, thereby providing a zoom ratio of about 300:1, which is more than three times the zoom ratio presently available in broadcast television zoom lens systems. Referring more particularly to the optical diagram of Fig. 10, the zoom lens system ZL is comprised of a focus lens group FG, a front zoom group FZG and a rear zoom group RZG. For the description of this embodiment, the lens system's stop is used as a divider between the "front" and "rear" of the lens. In terms of the terminology used in the "Description of Various Features of the Invention and the Disclosed Embodiments" set forth above, the focus lens group FG is the focus unit, the front zoom group FZG is the first optical unit, and the rear zoom group RZG includes a pupil imaging unit and an image stabilization unit, as well as the second optical unit.

The focus group FG is comprised of seven lens elements 1-7 with the front lens element 1 being stationary whereby the lens may be sealed at the front by fixing and sealing element 1 to the lens barrel (not shown). Lens element 2 comprises a first focus group FG1 and

lens elements 3 and 4 comprise a second focus group FG2, both of which groups are independently movable for achieving the desired focus at each focal length. Elements 5-7 of the focus group FG are stationary.

The front zoom group FZG has a first zoom group ZG1 comprised of lens  
5 elements 8-11 and a second zoom group ZG2 comprised of lens elements 12-15, both of which zoom groups are independently movable. An iris or aperture stop STOP is positioned between the second zoom group ZG2 and a first group RG1 that forms the front portion of the rear zoom group RZG.

First group RG1 is comprised of lens elements 16-25, which remain stationary.  
10 The intermediate image is formed between lens elements 22 and 23 in the first group RG1. Although all of the lens elements 16-25 of this first group RG1 remain stationary at all times, the intermediate image moves along the optical axis between lens elements 22 and 23 at the longer focal lengths without touching either of those elements during the zooming of the lens system between the maximum and minimum focal lengths. The next lens group of the rear zoom group  
15 RZG is a third zoom group ZG3 comprised of lens elements 26-28 that are movable axially. Next within the rear zoom group RZG is a second group RG2 comprised of lens elements 29-33, which are stationary. The next elements in the rear zoom group RZG comprise a stabilization group SG having a radial decentralization group SG1 with lens elements 34-36 and an axially adjustable group SG2 with lens elements 37-39. The three zoom groups ZG1, ZG2 and ZG3 are  
20 independently movable along the optical axis for developing the full range of the focal lengths of about 7mm to 2100mm. Finally, although they are not part of the zoom lens system per se, Fig. 10 also illustrates two prism blocks 40 and 41 that emulate the conventional three CCD 2/3" detectors of a video camera for completing the optical diagram from object space to the final  
25 image.

25 The first or decentralization stabilization group SG1 is movable radially from the system's optical axis in any direction by about 0.5 mm or more in response to sensed vibrations of the lens to maintain the final image at the image plane in a stabilized location. The sensing of vibrations and the movement of group SG1 may be accomplished by any conventional means such as an accelerometer, a processor and a motor controlled by the processor in a closed loop  
30 system on a continuous basis. The second or axial stabilization group SG2 is axially movable for axial adjustment of about 1.25 mm or more in either direction for back focus adjustment. The

second stabilization group SG2 may also be moved axially forward a greater amount for extended close focus at short focal lengths of the lens. The light rays between the first stabilization group SG1 and the second stabilization group SG2, i.e. between lens elements 36 and 37, are substantially collimated whereby the movements of those two groups for  
5 accomplishing stabilization, extending the close focus and adjusting the back focus do not cause any significant deterioration of the final image.

The decentralization stabilization group SG1 may also be used for creating special effects by causing the lens group SG1 to move radially in a shaking pattern to thereby simulate the shaking caused, for example, by an earthquake, a moving vehicle or explosions in a war  
10 movie. Such special effects can also be produced by moving the lens group SG2 axially in an oscillatory fashion, which slightly defocuses the picture. Radial movement of SG1 can also be combined with axial movement of SG2 to create a different special effect.

The complete lens design of the zoom lens system ZL for the embodiment of Figs. 10-62 is set forth below in the tables generally entitled "Tables for Figs. 10 thru 62." The  
15 Lens System Optical Prescription table is similar to the foregoing lens prescriptions for the zoom lenses of Figs. 6A-9B. A more detailed explanation of the tables is provided following the tables.

## TABLES FOR FIGS. 10 thru 62

## LENS SYSTEM OPTICAL PRESCRIPTION

Surface	Radius	Thickness	Glass Name	Manufacturer	Semi Aperture
OBJECT	Infinity	Variable			
S1	Infinity	50.000			142.85
S2	-553.385	5.200	SLAL13	OHARA	111.77
S3	436.730	Variable			103.81
S4	-1545.910	4.900	STIH6	OHARA	102.97
S5	682.341	Variable			101.63
S6	1644.762	19.482	SFPL52	OHARA	101.59
S7	-467.261	0.730			101.38
S8	-2000.000	0.000			99.83
S9	4000.000	0.000			99.22
S10	1463.863	12.601	SFPL51	OHARA	98.87
S11	-1094.948	Variable			98.22
S12	1092.461	20.386	SFPL51	OHARA	100.60
S13	-480.155	0.730			101.05
S14	362.425	21.232	SFPL51	OHARA	101.85
S15	-14624.000	0.730			101.37
S16	181.063	24.150	SFPL53	OHARA	97.84
S17	477.885	0.000			96.42
S18	324.818	Variable			95.12
S19	208.678	3.120	SLAH66	OHARA	38.27
S20*	40.147	6.111			32.19
S21	67.136	3.150	SLAH59	OHARA	32.03
S22	56.870	14.527			30.64
S23	-98.690	2.730	SLAH66	OHARA	30.54
S24	90.992	12.506	STIH53	OHARA	33.74
S25	-174.619	Variable			34.43
S26	764.771	14.926	SFPL52	OHARA	36.34
S27	-66.842	0.400			36.91
S28	133.738	17.704	SFPL51	OHARA	36.84
S29	-69.988	3.100	SLAM66	OHARA	36.62
S30	-1580.221	0.400			36.97
S31	65.214	9.613	SNSL36	OHARA	37.33
S32	129.561	Variable			36.67
STOP	Infinity	8.811			20.27
S34*	-36.392	2.044	SBSM14	OHARA	20.44
S35	-425.016	6.131			21.70
S36	-43.308	5.233	STIH53	OHARA	21.88
S37	-33.861	0.200			22.78
S38	47.203	13.980	SFPL51	OHARA	22.84
S39	-41.565	2.400	SLAM66	OHARA	22.59
S40	-56.845	0.200			22.47
S41	-109.533	1.950	SLAH63	OHARA	21.13
S42	31.532	10.159	SFPL51	OHARA	19.56
S43	-173.403	45.721			19.51
S44	47.891	4.513	SLAH53	OHARA	15.23
S45	-2514.287	41.843			14.84
S46	-23.807	9.483	SLAH59	OHARA	8.45
S47	-24.610	12.719			9.87
S48	61.223	3.114	SFPL51	OHARA	8.86
S49	-45.071	0.150			8.71
S50	24.918	3.242	SBSM9	OHARA	8.83
S51	-516.606	Variable			8.67
S52	-72.073	1.059	SLAL54	OHARA	7.15
S53	23.513	2.783			6.65
S54	-18.951	0.900	SLAH59	OHARA	6.54
S55	-57.174	1.347			6.84
S56	-21.150	21.292	SLAH60	OHARA	6.98

S57	-31.181	Variable			12.67
S58	-138.459	4.401	SBAL22	OHARA	23.12
S59	-75.648	0.300			23.54
S60	606.713	5.842	SFPL51	OHARA	23.89
S61	-96.488	0.300			23.97
S62	113.288	7.382	SFPL51	OHARA	23.55
S63	-97.742	2.500	STIH6	OHARA	23.30
S64	-366.723	0.300			23.05
S65	400.000	0.000			22.80
S66	38.760	8.585	SFPL52	OHARA	21.88
S67	269.438	5.901			21.07
S68	115.000	0.450			18.30
S69	94.072	1.770	SLAL54	OHARA	18.00
S70	35.982	7.000			16.65
S71	-90.502	2.010	SLAL8	OHARA	16.35
S72	29.972	6.150	STIH53	OHARA	16.01
S73	82.308	2.725			15.75
S74	79.000	9.670			15.78
S75	76.232	6.100	SPHM52	OHARA	15.87
S76	-75.003	0.761			15.66
S77	45.420	7.170	SFSL5	OHARA	14.38
S78	-45.317	1.500	STIH53	OHARA	13.58
S79	348.342	18.544			12.98
S80	Infinity	13.200	SBSL7	OHARA	10.30
S81	Infinity	2.000			9.00
S82	Infinity	33.000	BAF52	SCHOTT	8.70
S83	Infinity	0.000			5.69
S84	Infinity	0.000			
IMAGE	Infinity	0.000			

Note: Maximum image diameter = 11.0mm

\* Surface profiles of aspheric surfaces S20 and S34 are governed by the following conventional equation:

$$Z = \frac{(\text{CURV})Y^2}{1+(1-(1+K)(\text{CURV})^2Y^2)^{1/2}} + (A)Y^4 + (B)Y^6 + (C)Y^8 + (D)Y^{10}$$

where: CURV = 1/ (Radius of Surface)

Y = Aperture height, measured perpendicular to optical axis

K, A, B, C, D = Coefficients

Z = Position of surface profile for a given Y value, as measured along the optical axis from the pole (i.e. axial vertex) of the surface.

The coefficients for the surface S20 are:

K=	-0.3564030
A=	-8.06827e-07
B=	-2.15109e-10
C=	-6.36649e-14
D=	-3.89379e-18

The coefficients for the surface S34 are:

K=	0.4304790
A=	9.57697e-07
B=	1.31318e-09
C=	-1.45592e-12
D=	3.19536e-15

	VARIABLE THICKNESS POSITIONS AND DATA						
	P1	P2	P3	P4	P5	P6	P7
EFL	7.391	8.820	12.231	19.219	32.730	64.634	-93.220
F/No.	1.949	1.949	1.949	1.949	1.949	1.949	2.010
S0	Infinity	Infinity	5322.630	2499.896	Infinity	5322.630	Infinity
S3	19.882	19.882	49.699	78.333	19.882	49.699	19.882
S5	5.690	5.690	10.880	15.384	5.690	10.879	5.690
S11	71.522	71.522	36.516	3.376	71.522	36.516	71.522
S18	1.350	26.428	67.051	110.745	155.094	189.151	203.856
S25	319.660	292.522	247.857	197.854	142.790	92.653	65.474
S32	9.625	11.684	15.727	22.036	32.751	48.830	61.304

S51	1.498	1.498	1.498	1.498	1.498	1.498	2.823
S57	63.257	63.257	63.257	63.257	63.257	63.257	61.933

VARIABLE THICKNESS POSITIONS AND DATA							
	P8	P9	P10	P11	P12	P13	P14
EFL	145.184	206.228	490.401	717.511	2065.045	-3694.934	-920.968
F/No.	2.090	2.360	2.840	5.600	13.064	13.064	13.064
S0	5322.630	Infinity	5322.630	Infinity	Infinity	8708.002	4050.000
S3	49.699	19.882	49.699	19.882	19.882	38.428	57.882
S5	10.879	5.690	10.879	5.690	5.690	9.057	12.294
S11	36.516	71.522	36.516	71.522	71.522	49.608	26.917
S18	210.392	215.814	218.877	223.339	224.980	224.980	224.980
S25	50.046	33.074	24.338	10.235	1.719	1.719	1.719
S32	70.197	81.746	87.419	97.063	103.934	103.934	103.934
S51	4.711	9.572	14.559	31.080	63.536	63.536	63.536
S57	60.044	55.183	50.196	33.675	1.220	1.220	1.220

VARIABLE THICKNESS POSITIONS AND DATA						
	P15	P16	P17	P18	P19	P20
EFL	-509.031	-1739.084	-387.928	7.227	114.357	377.554
F/No.	16.750	5.600	5.600	1.949	2.010	2.360
S0	2499.896	5322.630	2499.896	2499.896	2499.896	2499.896
S3	78.333	49.699	78.333	78.333	78.333	78.333
S5	15.384	10.879	15.384	15.384	15.384	15.384
S11	3.376	36.516	3.376	3.376	3.376	3.376
S18	224.980	223.339	223.339	1.350	203.856	215.814
S25	1.719	10.235	10.235	319.660	65.474	33.074
S32	103.934	97.063	97.063	9.625	61.304	81.746
S51	63.536	31.080	31.080	1.498	2.823	9.572
S57	1.220	33.675	33.675	63.257	61.933	55.183

Surface Groups	Focal Lengths
S2 - S3	-349.648
S4 - S5	-581.962
S6 - S7	798.201
S10 - S11	1258.758
S12 - S13	672.072
S14 - S15	709.848
S16 - S17	646.676
S19 - S20	-64.565
S21 - S22	-526.211
S23 - S25	-554.999
S26 - S27	135.208
S28 - S30	113230.702
S31 - S32	240.348
S34 - S35	-65.863
S36 - S37	144.623
S38 - S40	60.255
S41 - S43	-70.987
S44 - S45	58.010
S46 - S47	205.873
S48 - S49	52.593
S50 - S51	38.634
S52 - S53	-27.000
S54 - S55	-34.933
S56 - S57	-2495.053
S58 - S59	284.851

S60 - S61	167.476
S62 - S64	292.466
S66 - S67	97.878
S69 - S70	-90.217
S71 - S73	-72.295
S75 - S76	61.902
S77 - S79	1261.227
S80 - S81	Infinity
S82 - S83	Infinity

The Lens System Optical Prescription table comprises the "Listing" for the lens specification and numerically lists each lens "SURFACE" in the left-hand column, but also includes dummy surfaces used in the design such as dummy surfaces S1, S8, S9, S18, S65, S74 and S84. The second column "Radius" lists the radius of the respective surfaces with a negative radius indicating that the center of curvature is to the left. The third column "Thickness" lists the thickness of the lens element or space from that surface to the next surface on the optical axis. The fourth column "Glass Name" lists the type of glass and the fifth column "Manufacturer" lists the manufacturer of each glass material. The fifth column "Semi Aperture" provides a measurement of half the aperture diameter for each lens element.

In the left-hand column the legend "OBJECT" means the object to be imaged (e.g., photographed), the legend "STOP" means the iris or stop, and the legend "IMAGE" means the final image. Each of the surfaces is identified by a numeral preceded by "S" to distinguish the surfaces from the numerals that identify the lens elements set forth on the subsequent pages comprising the 39 glass lens elements described above with respect to Fig. 10 and prisms 40 and 41 of the detector.

It should be noted that each of the thickness dimensions set forth in the third column of the table listing the surfaces is the element thickness or air space along the optical axis for the zoom lens system ZL set to the shortest focal lens (7.39 mm EFL) and focused at infinity. The air spaces adjacent the moving lens groups obviously will change in "thickness" for other focal lengths and focus distances.

For each aspheric surface, Aspheric Coefficients are provided following the table of optical prescriptions.

Figs. 11-30 illustrate 20 representative positions for the zoom lens system of Fig. 10. These 20 positions are listed in the following Table of Lens Positions:

TABLE OF LENS POSITIONS

Paraxial EFL (mm) @ Infinity Focus	"F" No.	Focus Distance (mm) To Object*				
		INF.	8758	5372	4100	2550
7.3909	1.95	1				18
8.8200	1.95	2				
12.1938	1.95			3		
18.6371	1.95					4
32.7300	1.95	5				
60.2959	1.95			6		
93.2199	2.01	7				19
127.2902	2.09			8		
206.2278	2.36	9				20
297.4279	2.84			10		
717.5114	5.60	11		16		17
2065.0447	13.06	12	13		14	15#

- 5 \* The Focus Distance is measured to the Object from the first refractive surface of the zoom lens system.  
# The "F" No. equals 16.75 at this position.

The twenty (20) positions were selected as representative of extreme positions of focal length and focus distance, as well as intermediate positions, for establishing the representative performances of the zoom lens system ZL of Fig. 10. In other words, position 1 is at the minimum paraxial focal length (wide angle) of about 7.4mm and focused at infinity whereas position 18 is focused at 2550 mm (about eight feet) for the same focal length. Similarly, position 12 represents the longest paraxial focal length of about 2065 mm at infinity focus whereas position 15 represents the focus at 2550 mm at the same paraxial focal length.

15 The paraxial EFL in the first column is at infinity focus. The "F" numbers are at any given focus and at full aperture. The 12 different focal lengths provide representative focal lengths over the full range of the zoom lens system ZL. Also, it should be noted that the actual field of view as a result of distortion and the available physical overtravel of the zoom groups beyond data in the lens system optical prescription set forth below produces an apparent focal length range of

substantially 7.0mm to 2100mm, i.e. a zoom ratio of about 300:1, with the distortion primarily influencing the reduction in the minimum paraxial EFL and the overtravel primarily influencing the increase in the maximum paraxial EFL. At 2100mm EFL with focus set at eight feet, the magnification is about 1.33:1.00 (object to image size). The nominal lens design for the  
5 embodiment of Figs. 10-62 as reflected in the lens optical prescription tables for Figs. 10-62 is given at 77° F (25° C, 298 K) and standard atmospheric pressure (760mm Hg).

Referring now to Figs. 11-30, the twenty positions 1-20 set forth in the foregoing lens system optical prescription and the preceding TABLE OF LENS POSITIONS are shown in that order. For example, Fig. 11 is an optical diagram of the lens elements in Position 1, namely,  
10 a paraxial effective focal length (EFL) of 7.391 mm and focused at infinity, wherein the first and second focus groups FG1 and FG2 are closely separated, the first and second zoom groups ZG1 and ZG2 are widely separated, and the third zoom group ZG3 is in its most forward position. On the other hand, Fig. 25 is the optical diagram representing Position 15 with the largest focal length and shortest focus distance, wherein the first and second focus groups FG1 and FG2 are  
15 both in their rearmost position, the first and second zoom groups ZG1 and ZG2 are in a closely spaced position but intermediately spaced between adjacent lens groups, and the third zoom group ZG3 is in the rearmost position.

Figs. 31-34 are enlarged optical diagrams of only the seven focus group FG elements 1-7 and illustrate representative Positions 1, 18, 12 and 15, respectively. It should be  
20 noted that while the lens element positions in Figs. 32 and 34 are the same, representing the focus distance of 2550 mm, the ray tracings are different because of the difference in the paraxial focal lengths from the minimum of about 7.4 mm in Fig. 32 to the maximum of about 2065 mm in Fig. 34.

Figs. 35 and 36 are enlarged optical diagrams illustrating the last lens element 7  
25 of the focus group FG and the first and second zoom groups ZG1 and ZG2 in Positions 1 and 12, respectively, for the minimum and maximum paraxial focal lengths, respectively. Similarly, Figs. 37 and 38 represent the rear zoom group RZG with the third zoom group ZG3 in the forwardmost and rearmost Positions 1 and 12 representing the minimum and maximum paraxial focal length positions, all respectively.

30 Referring now to Figs. 39-58, the ray aberration graphs for Positions 1-20, respectively, are shown in a conventional manner by five separate graphs with the maximum

field height at the top and zero field height at the bottom and for five wavelengths, as listed thereon. As will readily appear to those skilled in the art, these performance curves establish that in all 20 positions the zoom lens system performs exceptionally well for current broadcast television NTSC quality and exceptionally well for HDTV broadcast television quality. While  
5 Fig. 50 representing Position 12, illustrates wide variations in the ray aberrations at this focal length and focused at infinity, the performance is satisfactory because the modulation transfer function is close to the diffraction limit. Similarly, Figs. 52 and 53, representing Positions 14 and 15, respectively, illustrate widely varying ray aberrations but are still acceptable relative to diffraction limits for these close focus and long focal length positions.

10 Referring now to Fig. 59, the cam graph for the first and second focus groups FG1 and FG2 are shown (left and right, respectively) for the full range of focus travel thereof from infinity to close focus, with object space being to the left. The first and second focus groups FG1 and FG2 move separately and not at precisely the same rate, even though the solid cam lines in Fig. 59 look nearly parallel. The crosshatched portions at the top and bottom of Fig. 59 allow for  
15 temperature changes, manufacturing tolerances and fabrication adjustments. Similarly, Fig. 60 illustrates the cam graphs for the three zoom groups ZG1, ZG2 and ZG3 from left to right, respectively, and it is readily apparent that all three zoom groups move independently, although coordinated to achieve the desired focal lengths continuously over the entire range. Fig. 61 is a graph of the "f" number of the open stop relative to the paraxial effective focal length. Similarly,  
20 Fig. 62 is a graph of the full aperture full stop diameter relative to the paraxial effective focal length throughout the full range thereof.

**Detailed Description of Other Embodiments.** Figs. 63 and 64 illustrate an example of another embodiment of the present invention. This embodiment of the zoom lens system is very similar to the embodiment of Figs. 8A and 8B, except that a binary (diffractive)  
25 surface is provided. Specifically, a binary surface is provided on the front surface (surface No. 3 in the prescription) of the second lens element. The lens system optical prescription is set forth below in the tables generally entitled "Tables for Figs. 63 and 64." A more detailed explanation of the tables is provided following the tables.

## TABLES FOR FIGS. 63 and 64

## LENS SYSTEM OPTICAL PRESCRIPTION

Surface	Radius	Thickness	Glass Name
OBJECT	Infinity	Infinity	
S1	-731.222	10.000	LASF32
S2	390.798	15.991	
S3#	827.075	22.500	BK7
S4	-1021.418	0.100	
S5	1257.463	19.600	BK7
S6	-780.160	0.100	
S7	436.979	24.300	BK7
S8	-835.454	0.100	
S9	170.301	28.500	BK7
S10	655.827	Variable	
S11	278.083	2.650	S-LAH66
S12*	60.022	12.668	
S13	277.706	2.900	S-LAH66
S14	98.325	19.233	
S15	-70.105	3.050	S-LAH66
S16	234.965	14.100	S-TIH53
S17	-127.001	Variable	
S18	-404.763	9.200	S-FPL51
S19	-80.933	0.126	
S20	157.360	15.650	S-FPL51
S21	-99.532	2.750	S-LAM66
S22	-284.625	10.687	
S23	76.300	7.900	S-FPL51
S24	118.669	Variable	
STOP	Infinity	6.800	
S26*	-34.999	6.500	BAF4
S27	54.435	0.106	
S28	55.347	4.050	S-TIH4
S29	158.504	4.934	
S30	-64.093	5.050	S-TIH6
S31	-39.812	2.240	
S32	56.945	10.900	S-FPL52
S33	-43.914	2.150	S-LAM66
S34	-61.923	2.158	
S35	106.356	2.100	S-LAM66
S36	30.350	11.600	S-FPL51
S37	151.277	78.890	
S38	57.056	9.670	SF6
S39	-603.641	20.924	
S40	-22.693	19.750	S-LAM66
S41	-34.224	5.803	
S42	-129.563	12.646	S-FPL51
S43	-52.914	0.152	
S44	59.828	5.419	S-FPL51
S45	-209.080	0.100	
S46	37.693	6.143	S-LAL61
S47	177.702	Variable	
S48	-106.846	1.600	S-LAH55
S49	21.576	6.448	
S50	-27.697	6.650	S-LAM66
S51	7367.260	0.829	
S52	129.249	5.126	S-TIH53
S53	-46.358	Variable	
S54	538.505	1.500	S-LAM66
S55	95.344	11.395	S-PHM53

S56	-60.650	Variable	
S57	87.009	5.185	S-FSL5
S58	-165.647	1.434	
S59	-85.357	1.500	S-TIH6
S60	-1236.715	0.100	
S61	50.067	7.563	S-LAL14
S62	539.692	18.000	
S63	Infinity	13.537	S-BSL7
S64	Infinity	2.051	
S65	Infinity	33.841	BAF52
S66	Infinity	Variable	
IMAGE	Infinity		

Note: Maximum image diameter = 11.0mm

\* Surface profiles of aspheric surfaces S12 and S26 are governed by the following conventional equation:

$$Z = \frac{(\text{CURV})Y^2}{1+(1-(1+K)(\text{CURV})^2Y^2)^{1/2}} + (A)Y^4 + (B)Y^6 + (C)Y^8 + (D)Y^{10}$$

where: CURV = 1/ (Radius of Surface)  
 Y = Aperture height, measured perpendicular to optical axis

K, A, B, C, D = Coefficients  
 Z = Position of surface profile for a given Y value, as measured along the optical axis from the pole (i.e. axial vertex) of the surface.

The coefficients for the surface S12 are:		The coefficients for the surface S26 are:	
K=	0.01925737	K=	-0.5574845
A=	-1.3531387e-007	A=	-1.0833227e-006
B=	-1.5274225e-011	B=	-9.1904879e-011
C=	-2.0209982e-014	C=	-1.4775967e-013
D=	5.4753514e-018	D=	6.5701323e-016

# Surface profile of binary surface S3 is governed by the following conventional equation:

$$\text{Added Phase} = A_1p^2 + A_2p^4 + A_3p^6 + A_4p^8 + A_5p^{10}$$

where: A<sub>1</sub>, A<sub>2</sub>, A<sub>3</sub>, A<sub>4</sub> and A<sub>5</sub> are coefficients and p is the normalized radial coordinate at the surface.  
 The normalizing factor is set at unity and the p's become simply radial coordinates.

A1=	-0.14123699
A2=	-8.7028052e-007
A3=	-1.2255122e-010
A4=	5.9987370e-015
A5=	-1.2234791e-019

VARIABLE THICKNESS POSITIONS AND DATA							
	P1	P2	P3	P4	P5	P6	P7
EFL	7.264	12.117	35.980	81.979	145.198	729.922	2100.036
F/No.	1.450	1.450	1.450	1.450	1.450	9.400	14.100
S10	3.154	50.878	126.861	163.460	167.963	167.403	168.654
S17	271.009	213.056	113.646	61.255	10.607	68.828	3.277
S24	2.350	12.345	35.982	51.876	97.922	40.276	104.616
S47	4.632	5.482	4.658	5.264	6.015	53.226	73.878
S53	105.364	104.868	105.482	104.798	103.775	14.725	2.050
S56	1.550	1.550	1.550	1.550	1.550	43.752	35.462
S66	4.969	4.799	4.853	4.815	5.202	4.818	5.114

The prescription of binary surface 3 is included following the lens system optical prescription table listed above. The binary surface 3 adds phase to the wavefront. By providing binary surface 3, the second through fifth lens elements 2, 3, 4 and 5 in the focus portion of the lens can be made from relatively inexpensive glass, such as BK7, rather than expensive optical glass  
5 having abnormal dispersion characteristics, such as SFPL 51. While it is advantageous to include this binary surface 3 near the front of the lens system where the axial beam diameters are largest, it will readily appear to those skilled in the art that the binary (diffractive) surface may be provided elsewhere and that more than one such surface may be provided. Other methods of aberration correction may also be used advantageously. It should be noted that this embodiment  
10 also incorporates two aspheric surfaces 12 and 26.

Fig. 63 shows the zoom lens system with the zoom groups positioned at the longest focal length and the focus group focused at infinity. Similarly, the ray aberration graphs of Fig. 64 are at infinity focus and maximum focal length. It should be noted that the use of a binary surface in this embodiment is a modification that may be used in any of the embodiments  
15 of the invention disclosed herein or future variations of the invention.

Figs. 65 and 66 illustrate an example of another embodiment of the present invention. This embodiment of the zoom lens system of the present invention is very similar to the embodiment of Figs. 10-62, except that a binary (diffractive) surface is provided. Specifically, the binary surface is provided on the front surface (surface No. 6 in the  
20 prescription) of the third lens element from the left. As described above with respect to Figs. 10-62, that third lens element is the first (front) of two lens elements comprising the second focus group FG2, which is movable axially for accomplishing the focusing together with the movable first focus group FG1 comprised of only the second lens element. The lens system optical prescription for the embodiment of Figs. 65 and 66 is set forth below in the tables generally  
25 entitled "Tables for Figs. 65 and 66."

## TABLES FOR FIGS. 65 and 66

## LENS SYSTEM OPTICAL PRESCRIPTION

Surface	Radius	Thickness	Glass Name
OBJECT	Infinity	Variable	
S1	Infinity	50.000	
S2	-617.930	5.200	S-LAM60
S3	425.207	Variable	
S4	-2291.780	4.900	S-TIH6
S5	545.459	Variable	
S6#	961.467	19.482	BK7
S7	-607.161	0.730	
S8	1355.262	12.601	BK7
S9	-1118.653	Variable	
S10	986.310	20.386	S-FPL51
S11	-502.874	0.730	
S12	343.826	21.232	S-FPL51
S13	64586.450	0.730	
S14	181.736	24.150	S-FPL53
S15	476.848	Variable	
S16	208.678	3.120	S-LAH66
S17*	40.147	6.111	
S18	67.136	3.150	S-LAH59
S19	56.870	14.527	
S20	-98.690	2.730	S-LAH66
S21	90.992	12.506	S-TIH53
S22	-174.619	Variable	
S23	764.771	14.926	S-FPL52
S24	-66.842	0.400	
S25	133.738	17.704	S-FPL51
S26	-69.988	3.100	S-LAM66
S27	-1580.221	0.400	
S28	65.214	9.613	S-NSL36
S29	129.561	Variable	
STOP	Infinity	8.811	
S31*	-36.392	2.044	S-BSM14
S32	-425.016	6.131	
S33	-43.308	5.233	S-TIH53
S34	-33.861	0.200	
S35	47.203	13.980	S-FPL51
S36	-41.565	2.400	S-LAM66
S37	-56.845	0.200	
S38	-109.533	1.950	S-LAH63
S39	31.532	10.159	S-FPL51
S40	-173.403	45.721	
S41	47.891	4.513	S-LAH53
S42	-2514.287	41.843	
S43	-23.807	9.483	S-LAH59
S44	-24.610	12.719	
S45	61.223	3.114	S-FPL51
S46	-45.071	0.150	
S47	24.918	3.242	S-BSM9
S48	-516.606	Variable	
S49	-72.073	1.059	S-LAL54
S50	23.513	2.783	
S51	-18.951	0.900	S-LAH59
S52	-57.174	1.347	
S53	-21.150	21.292	S-LAH60
S54	-31.181	Variable	
S55	-138.459	4.401	S-BAL22

S56	-75.648	0.300	
S57	606.713	5.842	S-FPL51
S58	-96.488	0.300	
S59	113.288	7.382	S-FPL51
S60	-97.742	2.500	S-TIH6
S61	-366.723	0.300	
S62	400.000	0.000	
S63	38.760	8.585	S-FPL52
S64	269.438	5.901	
S65	115.000	0.450	
S66	94.072	1.770	S-LAL54
S67	35.982	7.000	
S68	-90.502	2.010	S-LAL8
S69	29.972	6.150	S-TIH53
S70	82.308	2.725	
S71	79.000	9.670	
S72	76.232	6.100	S-PHM52
S73	-75.003	0.761	
S74	45.420	7.170	S-FSL5
S75	-45.317	1.500	S-TIH53
S76	348.342	18.544	
S77	Infinity	13.200	S-BSL7
S78	Infinity	2.000	
S79	Infinity	33.000	BAF52
S80	Infinity	0.000	
S81	Infinity	0.000	
IMAGE	Infinity		

Note: Maximum image diameter = 11.3mm

\* Surface profiles of aspheric surfaces S17 and S31 are governed by the following conventional equation:

$$Z = \frac{(\text{CURV})Y^2}{1+(1 - (1+K)(\text{CURV})^2Y^2)^{1/2}} + (A)Y^4 + (B)Y^6 + (C)Y^8 + (D)Y^{10}$$

where: CURV = 1/ (Radius of Surface)  
 Y = Aperture height, measured perpendicular to optical axis

K, A, B, C, D = Coefficients  
 Z = Position of surface profile for a given Y value, as measured along the optical axis from the pole (i.e. axial vertex) of the surface.

The coefficients for the surface S17 are:	The coefficients for the surface S31 are:
K= -0.3564029	K= 0.4304792
A= -8.6827410e-007	A= 9.5769727e-007
B= -2.1510889e-010	B= 1.3131850e-009
C= -6.3664850e-014	C= -1.4559220e-012
D= -3.8937870e-018	D= 3.1953640e-015

# Surface profile of binary surface S6 is governed by the following conventional equation:

$$\text{Added Phase} = A_1p^2 + A_2p^4 + A_3p^6 + A_4p^8 + A_5p^{10}$$

where: A<sub>1</sub>, A<sub>2</sub>, A<sub>3</sub>, A<sub>4</sub> and A<sub>5</sub> are coefficients and p is the normalized radial coordinate at the surface.  
 The normalizing factor is set at unity and the p's become simply radial coordinates.

A1=	-0.038094023
A2=	-2.7327913e-006
A3=	5.0795942e-010
A4=	-5.0245151e-014
A5=	1.5103625e-018

VARIABLE THICKNESS POSITIONS AND DATA							
	P1	P2	P3	P4	P5	P6	P7
EFL	7.428	12.285	19.009	32.781	65.564	93.100	144.823
F/No.	1.949	1.949	1.949	1.949	1.949	2.010	2.090
S0	Infinity	5322.630	2499.896	Infinity	5322.630	Infinity	5322.630
S3	18.151	48.521	79.959	18.151	48.521	18.151	48.521
S5	6.399	10.135	15.000	6.399	10.135	6.399	10.135
S9	71.409	37.303	1.000	71.409	37.303	71.409	37.303
S15	1.350	67.051	110.745	155.094	189.151	203.856	210.392
S22	319.660	247.857	197.854	142.790	92.653	65.474	50.046
S29	9.625	15.727	22.036	32.751	48.830	61.304	70.197
S48	1.498	1.498	1.498	1.498	1.498	2.823	4.711
S54	63.257	63.257	63.257	63.257	63.257	61.933	60.044

VARIABLE THICKNESS POSITIONS AND DATA						
	P8	P9	P10	P11	P12	P13
EFL	206.030	486.383	715.335	2050.042	4776.501	1890.393
F/No.	2.360	2.840	5.600	14.500	14.500	5.600
S0	Infinity	5322.630	Infinity	Infinity	8708.002	5322.630
S3	18.151	48.521	18.151	18.151	37.472	48.521
S5	6.399	10.135	6.399	6.399	8.770	10.135
S9	71.409	37.303	71.409	71.409	49.718	37.303
S15	215.814	218.878	223.339	224.980	224.980	223.339
S22	33.074	24.338	10.235	1.719	1.719	10.235
S29	81.746	87.419	97.063	103.934	103.934	97.063
S48	9.572	14.559	31.080	63.536	63.536	31.080
S54	55.183	50.196	33.675	1.220	1.220	33.675

The prescription of binary surface 6 is included following the lens system optical prescription table listed above. The addition of binary surface 6 to the basic lens system optical prescription of the embodiment of Figs. 10-62 allows the substitution of less expensive glass, such as BK7, for the fluor-crown glass of lens elements 3 and 4 (third and fourth from the left in Fig 65). Although other small changes are also made in the prescription, the zoom lens system of Figs. 65 and 66 has the same number of lens elements and the same number of moving groups for focusing and zoom as the embodiment of Figs. 10-62. Fig. 65 shows the zoom lens system with the zoom groups positioned at the longest focal length and the focus groups focused at infinity. Similarly, the ray aberration graphs of Fig. 66 are at infinity focus and the longest focal length.

Figs. 67-70 illustrate an example of another embodiment of the present invention. This embodiment of the zoom lens system of the present invention has a zoom ratio of about 400:1. Specifically, this embodiment has a zoom range of focal lengths of about 7.47mm (the position shown in Fig. 67) to about 2983mm (the position shown in Fig. 68). As with the embodiment of Figs. 10-62, this embodiment has three moving zoom lens groups ZG1, ZG2 and ZG3, with two of them in the front zoom lens portion and one in the rear zoom lens portion. The ray aberration graphs of Figs. 69 and 70 are at paraxial effective focal lengths (EFL) of 7.47mm and 2983mm, respectively, and illustrate that this embodiment performs well, considering the extremely wide range of focal lengths and large zoom ratio which is similar to the performance characteristics of the embodiment of Figs. 10-62. The optical diagrams of Figs. 67 and 68 and the ray aberration graphs of Figs. 69 and 70 are shown at infinity focus.

The lens system optical prescription of Figs. 67-70 is set forth below in the tables generally entitled "Tables for Figs. 67 thru 70." The following data in the lens system optical prescription is set forth in the same manner and the legends have the same meanings as in the preceding lens system optical prescriptions.

## TABLES FOR FIGS. 67 thru 70

## LENS SYSTEM OPTICAL PRESCRIPTION

Surface	Radius	Thickness	Glass Name
OBJECT	Infinity	Variable	
S1	1018.780	15.000	LAH78
S2	277.432	28.775	
S3	523.118	37.500	S-FPL51
S4	-634.022	1.500	
S5	323.390	30.000	S-FPL51
S6#	-2096.922	-0.001	
S7*	177.503	27.000	S-FPL51
S8	667.737	Variable	
S9	363.133	6.000	TAF1
S10*	84.560	23.084	
S11	-1731.870	4.500	TAF1
S12	117.736	21.933	
S13	-68.241	4.672	TAF1
S14	1396.861	11.280	PBH71
S15	-123.171	Variable	
S16	-351.922	21.562	S-FPL51
S17	-87.960	0.750	
S18	670.190	25.507	LAK21
S19	-96.809	4.500	FD6
S20	-253.794	18.318	
S21	112.307	6.052	FCS
S22	345.143	Variable	
STOP	Infinity	6.066	
S24*	-49.612	4.500	PSK53A
S25	45.951	6.491	FD15
S26	149.306	8.138	
S27	-53.675	2.556	PSK53A
S28	-436.714	15.264	FD8
S29	-53.001	30.067	
S30	96.369	40.439	S-FPL51
S31	-47.937	4.500	S-LAH75
S32	-65.887	0.018	
S33	314.723	4.500	S-LAH75
S34	44.980	33.625	S-FPL53
S35	-197.211	62.647	
S36*	59.624	15.000	S-FPL53
S37	-45862.250	62.567	
S38	Infinity	2.000	
S39	-250.000	2.000	S-LAH66
S40	38.600	21.997	
S41	-42.668	3.012	PBH23W
S42	78.619	20.849	S-LAL8
S43	-54.572	0.250	
S44	701.714	11.340	S-LAL8
S45	-96.232	0.250	
S46	153.694	14.173	S-LAL8
S47	-120.652	0.250	
S48	57.764	24.753	S-LAM2
S49	-654.450	3.706	PBH6W
S50	36.175	17.533	
S51	126.517	2.500	PBH53W
S52	123.911	5.000	S-BSM14
S53	-269.378	0.200	
S54	119.317	5.000	S-BSM18
S55	249.395	Variable	
S56	77.473	2.500	S-LAH60
S57	24.795	8.736	

S58	-17.880	2.000	S-LAH55
S59	-73.667	1.561	
S60	-68.965	7.000	PBH53W
S61	-23.620	0.200	
S62	-39.257	2.000	S-LAH65
S63	-73.267	Variable	
S64*	40.900	24.089	S-BAL42
S65*	-82.736	0.200	
S66	68.814	3.000	PBH53W
S67	33.834	Variable	
S68	47.963	12.055	S-BSL7
S69	-38.097	8.000	PBH6W
S70	-61.203	Variable	
S71	Infinity	11.874	S-BSL7
S72	Infinity	14.000	
IMAGE	Infinity		

Note: Maximum image diameter = 11.0mm

\* Surface profiles of aspheric surfaces S7, S10, S24, S36, S64 and S65 are governed by the following conventional equation:

$$Z = \frac{(CURV)Y^2}{1+(1-(1+K)(CURV)^2Y^2)^{1/2}} + (A)Y^4 + (B)Y^6 + (C)Y^8 + (D)Y^{10} + (E)Y^{12}$$

where: CURV = 1/ (Radius of Surface)  
 Y = Aperture height, measured perpendicular to optical axis

K, A, B, C, D, E = Coefficients  
 Z = Position of surface profile for a given Y value, as measured along the optical axis from the pole (i.e. axial vertex) of the surface.

The coefficients for the surface S7 are:

K= -0.01834396  
 A= 4.6192051e-009  
 B= 2.9277175e-013  
 C= -5.3760139e-018  
 D= 4.4429222e-022  
 E= 0

The coefficients for the surface S10 are:

K= 0.1385814  
 A= -6.1078514e-008  
 B= -1.7110958e-012  
 C= -1.4298682e-015  
 D= -7.3308393e-019  
 E= 0

The coefficients for the surface S24 are:

K= -0.1283323  
 A= -2.7157663e-007  
 B= 1.4568941e-010  
 C= -1.4055959e-012  
 D= 9.7130719e-016  
 E= 0

The coefficients for the surface S36 are:

K= 0.009973727  
 A= 3.3999271e-008  
 B= 1.4717268e-010  
 C= -1.0665963e-013  
 D= 6.8463872e-017  
 E= 0

The coefficients for the surface S64 are:

K= -4.594951  
 A= 5.9382510e-006  
 B= -4.3333569e-009  
 C= -2.6412286e-013  
 D= 5.0607811e-015  
 E= -3.8443669e-018

The coefficients for the surface S65 are:

K= -0.2743554  
 A= 1.2036084e-006  
 B= 3.8383867e-009  
 C= -1.5101902e-011  
 D= 2.3291313e-014  
 E= -1.3549754e-017

# Surface profile of binary surface S6 is governed by the following conventional equation:

$$\text{Added Phase} = A_1p^2 + A_2p^4 + A_3p^6 + A_4p^8 + A_5p^{10} + A_6p^{12}$$

where: A<sub>1</sub>, A<sub>2</sub>, A<sub>3</sub>, A<sub>4</sub>, A<sub>5</sub> and A<sub>6</sub> are coefficients and p is the normalized radial coordinate at the surface. The normalizing factor is set at unity and the p's become simply radial coordinates.

A1= -0.0183497  
 A2= 0.1385814  
 A3= -0.1283323  
 A4= 0.0099737  
 A5= -4.5949510  
 A6= -0.2743554

VARIABLE THICKNESS POSITIONS AND DATA							
	P1	P2	P3	P4	P5	P6	P7
EFL	7.471	11.746	18.475	29.059	45.676	649.701	2981.989
F/No.	1.600	1.600	1.600	1.600	1.600	6.000	18.000
S0	Infinity	Infinity	Infinity	Infinity	Infinity	Infinity	Infinity
S8	3.884	47.335	81.309	107.642	127.477	147.901	156.198
S15	243.496	190.547	145.303	105.453	68.586	39.080	0.104
S22	5.292	14.777	26.064	39.600	56.513	65.772	96.339
S55	1.000	1.000	1.000	1.000	1.000	98.702	111.239
S63	117.540	117.540	117.540	117.540	117.540	30.129	0.368
S67	42.175	42.175	42.175	42.175	42.175	20.670	63.421
S70	14.512	14.512	14.512	14.512	14.512	25.727	0.199

**Detailed Description of Folded Lens Embodiment.** Fig. 71 is an optical diagram illustrating an example of still another embodiment of the present invention incorporating one or more mirrors for folding the lens for added compactness. The example of Fig. 71 is similar to the previously-described embodiments, with three general zoom groups identified as 50, 52 and 54. An intermediate image is located at 56. The focus group 66 is movable during focusing, but is stationary when the lens is at a constant focus. The aperture stop is located at 84. Unique to the folded zoom lens embodiment of Fig. 71 is a mirror 64 located between the front and rear zoom groups 52 and 54 for "folding" or bending the radiation rays. The embodiment of Fig. 71 may be employed in any camera, but is particularly suited for small cameras such as point-and-shoot handheld cameras because the folded design enables the lens to fit into a smaller space. Fig. 71 illustrates an SLR embodiment containing a reflex mirror 60 and an eyelens 62 for enabling a user to see the image while the reflex mirror 60 is in the position indicated in Fig. 71.

Embodiments of the present invention are particularly suited to folding because mirror 64 may be placed within the intermediate image space 58 in any area that does not interfere with the movement of the zoom groups 52 and 54. In contrast, conventional compact zoom lenses have lens elements that must retract into the body of the camera, which eliminates most or all of the air gaps within the lens and precludes the insertion of a mirror. In the example of Fig. 71, the mirror 64 is located on the image side of the intermediate image 56. However, in other embodiments, the mirror 64 may be located on the object side of the intermediate image 56. It should be understood that other embodiments of the present invention may have multiple folds (mirrors), and that the mirrors need not be oriented at 45 degrees with respect to the optical axis.

The folded lens illustrated in the example of Fig. 71 enables several useful design possibilities and advantages. As mentioned above, the fold in the lens enables the zoom lens to take up less space. Furthermore, the folded zoom lens enables some or all of the lens elements to reside within the body of the camera, further improving compactness. In one embodiment, even the focus lens group 66 may reside entirely within the body of the camera, protecting the lens and making the camera even more compact. In addition, the folded zoom lens enables compact cameras to achieve a zoom ratio of about 10:1 or higher, compared to a maximum of about 4:1 in conventional compact cameras. Moreover, conventional SLR cameras require a bulky

pentaprism for flipping the image, and thus compact cameras typically avoid through-the-lens viewing. However, because of the intermediate image 56 and mirrors 64 and 60 in the present invention, the final image is already properly oriented without the need for a bulky pentaprism, and through-the-lens viewing is made possible even in cameras of a compact size.

5           The exemplary folded zoom lens of Fig. 71 provides an EFL of about 12mm to 120mm, a zoom ratio of about 10:1, an "f" number range of about  $f/3$  to  $f/5$  at full aperture and a maximum field of view angle in object space of about 84.1 degrees to 10.3 degrees, and receives radiation within a waveband of at least 486nm to 588nm. The image generated by the embodiment of Fig. 71 is about 12mm in height by about 18mm in width with a diagonal  
10          dimension of about 21.65mm, which is about half the size of the image in a conventional 35mm still photography camera.

          Figs. 72A-72D are optical diagrams illustrating the folded zoom lens example embodiment of Fig. 71 at other zoom positions, with the folded lens shown in a flat (unfolded) orientation for clarity and the zoom groups in various exemplary positions. As in Fig. 71, the  
15          focus lens group 66 in the example of Figs. 72A-72D is movable for focusing and stationary at a constant focus, and the mirror 64 and eyelens 62 are also stationary. The aperture stop is located at 84 and is movable during zooming. The zoom lens example of Figs. 72A-72D is actually comprised of eight moving zoom groups 68, 70, 72, 74, 76, 78, 80 and 82, although it should be understood that other embodiments of the folded zoom lens may include more or fewer zoom  
20          groups. The folded zoom lens example of Figs. 72A-72D utilizes all spherical surfaces, but it should be understood that other embodiments may employ aspheres and/or binary (diffractive) surfaces.

**Detailed Description of Infrared Embodiment.** Figs. 73A-73C are optical diagrams for an example of an infrared (IR) embodiment of the zoom lens system of the present  
25          invention, illustrating various positions of the zoom groups. The intermediate image is located at 86. The focus group 88 is movable during focusing, but is stationary at a constant focus. The final image plane is located at 90, and the aperture stop is located at 92. The embodiment of Figs. 73A-73C may be employed in low light and surveillance cameras because the zoom lens system is designed for infrared wavelengths. The example of Figs. 73A-73C provides an EFL of  
30          6.68mm to 1201.2mm, an "f" number range of  $f/2.00$  to  $f/5.84$ , an image diagonal of 8.0 mm, a maximum field of view angle in object space of 64.5 degrees to 0.388 degrees, and a vertex

length of 902.28mm. There is a -4.93% distortion at the 6.68mm focal length position and +0.34% distortion at the 1201.2mm focal length position. This distortion increases the effective zoom ratio to 190:1. There are a total of nine elements in the example of Figs. 73A-73C, with six elements (94, 96, 98, 100, 102 and 104) in the zoom kernel 106, and three elements (108, 110  
5 and 112) in the zoom relay 114. Note that the "zoom kernel," as referred to herein, represents all of the elements from object space to the intermediate image, while the "zoom relay," as referred to herein, represents all of the elements from the intermediate image to the final image.

The lens system optical prescription for the IR embodiment of Figs. 73A-73C is set forth below in the tables generally entitled "Tables for Figs. 73A, 73B and 73C." The  
10 following data in the lens system optical prescription is set forth in the same manner and the legends have the same meanings as in the preceding lens system optical prescriptions.

TABLES FOR FIGS. 73A, 73B and 73C

LENS SYSTEM OPTICAL PRESCRIPTION

Surface	Radius	Thickness	Refractive Material
OBJECT	Infinity	Infinity	
S1	Infinity	25.000	
S2*	341.091	15.000	GERMANIUM
S3#	442.256	14.496	
S4	628.089	15.000	ZNSE
S5	817.176	Variable	
S6*	191.321	5.000	GERMANIUM
S7	101.374	Variable	
S8	-108.986	5.000	GERMANIUM
S9	-133.542	Variable	
S10*	132.195	10.000	GERMANIUM
S11	215.451	106.451	
S12*	44.406	7.000	GERMANIUM
S13*	47.364	Variable	
S14*	-146.583	5.000	GERMANIUM
S15*	-103.306	Variable	
S16*	-48.015	6.000	ZNSE
S17*	-54.690	Variable	
S18*	-134.510	5.000	GERMANIUM
S19*	-96.541	Variable	
STOP	Infinity	74.251	
IMAGE	Infinity		

Note: Maximum image diameter = 8.0mm

\* Surface profiles of aspheric surfaces S2, S6, S10, S12, S13, S14, S15, S16, S17, S18 and S19 are governed by the following conventional equation:

$$Z = \frac{(\text{CURV})Y^2}{1+(1 - (1+K)(\text{CURV})^2Y^2)^{1/2}} + (A)Y^4 + (B)Y^6 + (C)Y^8 + (D)Y^{10} + (E)Y^{12} + (F)Y^{14} + (G)Y^{16}$$

where: CURV = 1/ (Radius of Surface)  
Y = Aperture height, measured perpendicular to optical axis

A, B, C, D, E, F, G = Coefficients  
Z = Position of surface profile for a given Y value, as measured along the optical axis from the pole (i.e. axial vertex) of the surface.

The coefficients for the surface S2 are:

K= -0.3170663  
A= 7.1675212e-010  
B= 4.6490286e-015  
C= 3.1509558e-020  
D= -3.0230207e-026  
E= 1.8711604e-043  
F= 7.2023035e-034  
G= -1.6899714e-038

The coefficients for the surface S6 are:

K= 0.0000000  
A= 8.8834511e-009  
B= -1.1017434e-012  
C= 4.2407818e-016  
D= -4.5843672e-020  
E= 0  
F= 0  
G= 0

The coefficients for the surface S10 are:

K= 0.0000000  
A= -4.1468720e-008  
B= -1.1864804e-012  
C= 1.0375271e-016  
D= 1.4819552e-020  
E= 0  
F= 0  
G= 0

The coefficients for the surface S12 are:

K= 0.1424633  
A= -1.3741884e-008  
B= 2.0574529e-010  
C= 2.2356569e-013  
D= -9.2592205e-016  
E= 0  
F= 0  
G= 0

The coefficients for the surface S13 are:

K= 0.1341907  
 A= 2.5853953e-007  
 B= 6.3040925e-010  
 C= -8.9182471e-013  
 D= -2.1087914e-016  
 E= 0  
 F= 0  
 G= 0

The coefficients for the surface S14 are:

K= 0.0000000  
 A= -2.3627230e-006  
 B= -3.2069853e-009  
 C= 1.9995538e-012  
 D= -4.1873811e-015  
 E= -4.5598387e-018  
 F= 1.5355757e-021  
 G= 2.7742963e-025

The coefficients for the surface S15 are:

K= 0.0000000  
 A= -1.9992749e-006  
 B= -2.7451965e-009  
 C= 2.5915567e-012  
 D= -5.4747396e-015  
 E= 1.0432409e-018  
 F= -9.7041838e-023  
 G= 3.5844261e-025

The coefficients for the surface S16 are:

K= 0.0000000  
 A= -5.5264489e-007  
 B= -3.4855834e-011  
 C= -1.5605019e-013  
 D= 8.4346229e-016  
 E= -2.6930213e-019  
 F= 7.0886850e-022  
 G= -4.8763355e-025

The coefficients for the surface S17 are:

K= 0.0000000  
 A= -1.9256081e-007  
 B= 9.7560057e-012  
 C= -3.1406997e-013  
 D= 4.6996712e-016  
 E= 4.3471337e-019  
 F= -3.7957715e-022  
 G= -2.4875152e-026

The coefficients for the surface S18 are:

K= 0.0000000  
 A= 4.5197079e-007  
 B= -4.7688707e-010  
 C= -2.2771179e-013  
 D= -7.3812375e-016  
 E= 6.1621050e-019  
 F= -2.9782920e-023  
 G= -2.8295343e-026

The coefficients for the surface S19 are:

K= 0.0000000  
 A= 3.9066750e-007  
 B= -2.6768710e-010  
 C= -3.7378469e-013  
 D= -4.0450877e-016  
 E= 3.9230103e-019  
 F= -3.7514135e-023  
 G= -8.0738327e-027

# Surface profile of binary surface S3 is governed by the following conventional equation:

$$\text{Added Phase} = A_1p^2 + A_2p^4 + A_3p^6 + A_4p^8 + A_5p^{10}$$

where:  $A_1, A_2, A_3, A_4$  and  $A_5$  are coefficients and  $p$  is the normalized radial coordinate at the surface.  
 The normalizing factor is set at unity and the  $p$ 's become simply radial coordinates.

A1= -0.0085882326  
 A2= -1.2587653e-008  
 A3= -5.4668365e-013  
 A4= 8.4183658e-018  
 A5= 1.3774055e-022

VARIABLE THICKNESS POSITIONS AND DATA						
	P1	P2	P3	P4	P5	P6
EFL	6.677	7.583	9.331	11.805	14.069	23.805
F/No.	2.000	2.000	2.000	2.000	2.000	2.000
S5	5.000	25.000	55.000	85.000	105.000	155.000
S7	239.848	216.543	180.384	143.845	119.259	58.715
S9	72.916	76.220	82.379	88.919	93.504	104.048
S13	276.674	276.674	276.674	276.674	276.674	276.674
S15	5.030	5.030	5.030	5.030	5.030	5.030
S17	29.517	29.517	29.517	29.517	29.517	29.517
S19	5.000	5.000	5.000	5.000	5.000	5.000

VARIABLE THICKNESS POSITIONS AND DATA					
P7	P8	P9	P10	P11	P12

EFL	48.419	84.275	133.455	175.637	231.172	304.215
F/No.	2.000	2.000	2.000	2.300	2.900	3.400
S5	205.000	231.305	243.545	243.545	243.545	243.545
S7	16.543	30.757	72.218	72.218	72.218	72.218
S9	96.221	55.701	2.000	2.000	2.000	2.000
S13	276.674	276.674	276.674	248.444	220.313	187.659
S15	5.030	5.030	5.030	42.180	79.972	109.931
S17	29.517	29.517	29.517	22.953	12.626	5.000
S19	5.000	5.000	5.000	2.644	3.310	13.631

VARIABLE THICKNESS POSITIONS AND DATA					
	P13	P14	P15	P16	P17
EFL	400.368	526.915	693.449	912.675	1201.182
F/No.	3.500	3.800	4.600	5.300	5.840
S5	243.545	243.545	243.545	243.545	243.545
S7	72.218	72.218	72.218	72.218	72.218
S9	2.000	2.000	2.000	2.000	2.000
S13	146.432	112.380	97.552	94.304	95.940
S15	114.831	95.642	67.311	40.305	16.014
S17	10.137	19.763	26.212	25.615	18.454
S19	44.821	88.436	125.146	155.997	185.814

Figs. 74-76 are ray aberration graphs corresponding to the position of the zoom groups shown in Figs. 73A-73C, respectively. The ray aberration graphs of Figs. 74-76 are at paraxial effective focal lengths (EFL) of 6.68mm, 133.46mm, and 1201.18mm, respectively, and a wavelength range of 8-12 microns. The optical diagrams of Figs. 73A-73C and the ray  
5 aberration graphs of Figs. 74-76 are shown at infinity focus.

Although the present invention has been fully described in connection with embodiments thereof with reference to the accompanying drawings, it is to be noted that various changes and modifications will become apparent to those skilled in the art. Such changes and modifications are to be understood as being included within the scope of the present invention as  
10 defined by the appended claims.

The claims defining the invention are as follows:

1. A zoom lens system for forming a final image of an object, said system having an object side and an image side and forming a first intermediate real image between the object and the final image, said system characterized by, in order from the object side to the image side:  
5 a first optical unit including at least two lens elements and located between the object and the first intermediate real image, said unit comprising at least one optical subunit which is moved to change the size (magnification) of the first intermediate real image;  
10 and  
15 a second optical unit including at least two lens elements and located between the first intermediate real image and the final image, at least a portion of which is moved to change the size (magnification) of the final image.  
20
2. The zoom lens system as recited in claim 1, the second optical unit comprising at least one optical subunit, and at least one of the optical subunits is movable to hold an axial position of the final image substantially stationary as the focal length of the system is  
25 changed.
3. The zoom lens system as recited in claim 1, wherein the second optical unit comprises at least one optical subunit and at least one of the optical subunits in  
30 each of the first and second optical units moves continuously as the focal length of the system is changed.

4. The zoom lens system as recited in claim 1, wherein the second optical unit comprises at least one optical subunit and at least one of the optical subunits in one of the first and second optical units is at least temporarily stationary while at least one of the optical subunits in the other of the first and second optical units moves as the focal length of the system is changed.
5. The zoom lens system as recited in claim 1, wherein:
- (a) the second optical unit comprises at least one optical subunit; and
  - (b) a change in the focal length of the system includes at least one first motion and at least one second motion wherein:
    - (i) the first motion can precede or follow the second motion;
    - (ii) for the first motion, at least one optical subunit of the first optical unit moves without movement of any optical subunit of the second optical unit; and
    - (iii) for the second motion, at least one optical subunit of the second optical unit moves without movement of any optical subunit of the first optical unit.
6. The zoom lens system as recited in claim 5, wherein a change in the focal length of the system includes only a single first motion and a single second motion.
7. The zoom lens system as recited in claim 1, further comprising a focus unit on the object side of the first

optical unit for focusing at least one of the intermediate and final images.

- 5 8. The zoom lens system as recited in claim 1, wherein the first optical unit comprises an aperture stop and the system further comprises a pupil imaging unit located between the first and second optical units for imaging an exit pupil of the first optical unit to form an entrance pupil of the second optical unit.
- 10 9. The zoom lens system as recited in claim 1, wherein the second optical unit comprises an aperture stop and the system further comprises a pupil imaging unit located between the first and second optical units for imaging an entrance pupil of the second optical unit to form an exit pupil of the first optical unit.
- 15 10. The zoom lens system as recited in claim 1, further comprising an image stabilization unit on the image side of the second optical unit for stabilizing the final image.
- 20 11. The zoom lens system as recited in claim 7, the focus unit comprising two optical subunits that are movable along the optical axis of the zoom lens system.
- 25 12. The zoom lens system as recited in claim 11, wherein the optical axis is straight.
- 30 13. The zoom lens system as recited in claim 7, the focus unit comprising seven or fewer lens elements.

14. The zoom lens system as recited in claim 10, the image stabilisation unit comprising at least one lens element that is laterally movable off the optical axis of the zoom lens system.

5

15. The zoom lens system as recited in claim 10, the image stabilisation unit comprising at least one lens element that is axially movable along the optical axis of the zoom lens system.

10

16. The zoom lens system as recited in claim 10, the image stabilisation unit comprising at least one laterally movable lens element that is laterally movable off the optical axis of the zoom lens system and at least one axially movable lens element that is axially movable along the optical axis, the at least one laterally movable lens element separated from the at least one axially movable lens element by an air gap, wherein radiation from the object and passing through the air gap is substantially collimated.

15

17. The zoom lens system as recited in claim 14, wherein radiation from the object and passing through the system is substantially collimated as it leaves the at least one laterally movable lens element.

20

18. The zoom lens system as recited in claim 15, wherein radiation from the object and passing through the system is substantially collimated as it enters the at least one axially movable lens element.

25

19. The zoom lens system as recited in claim 1, wherein one or more additional intermediate real images are formed between the object and the final image.
- 5 20. The zoom lens system as recited in claim 19, further comprising one or more additional optical units for changing the size (magnification) of the one or more additional intermediate real images.
- 10 21. The zoom lens system as recited in claim 1, wherein the first intermediate real image is formed in an air space between optical elements in the zoom lens system and remains in the air space during zooming.
- 15 22. The zoom lens system as recited in claim 19, wherein the one or more additional intermediate real images are formed in one or more air spaces between optical elements in the zoom lens system and remain in the one or more air spaces during zooming.
- 20 23. The zoom lens system of claim 1, wherein the system comprises at least one aspheric optical surface.
24. The zoom lens system of claim 1, wherein the system  
25 comprises at least one diffractive optical surface.
25. The zoom lens system of claim 1, wherein the system comprises at least one aspheric optical surface and at least one diffractive optical surface.

2003252012 19 Jul 2006

26. A zoom lens system for forming a final image of an object, said system being substantially as hereinbefore described with reference to any one embodiment, as that embodiment is depicted in the accompanying drawings.

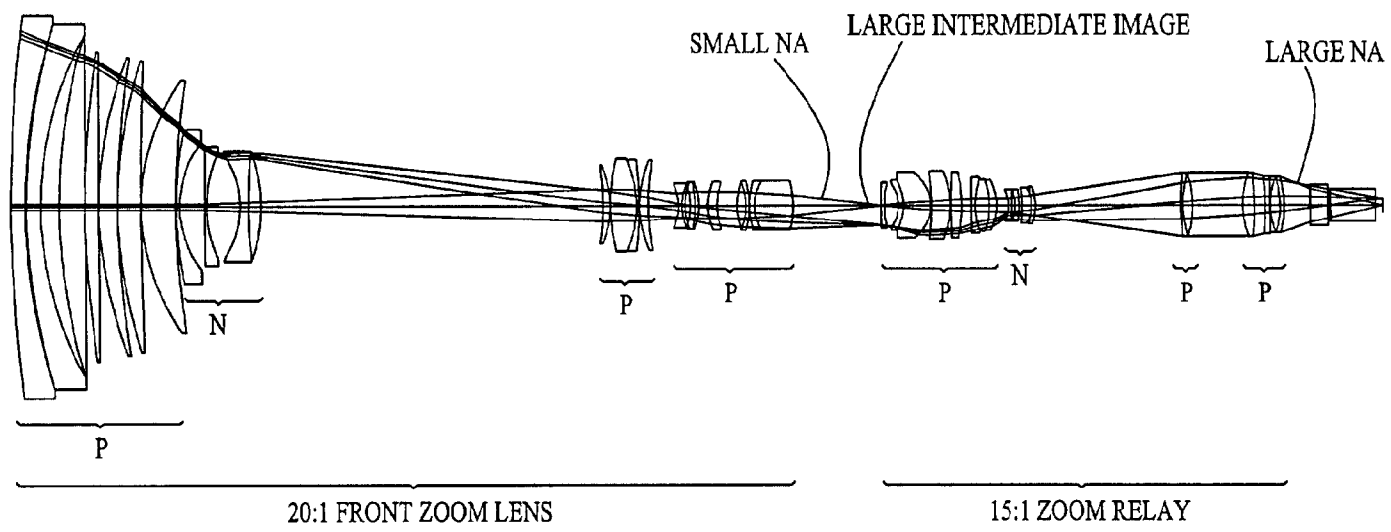
5

**Dated 18 July 2006**

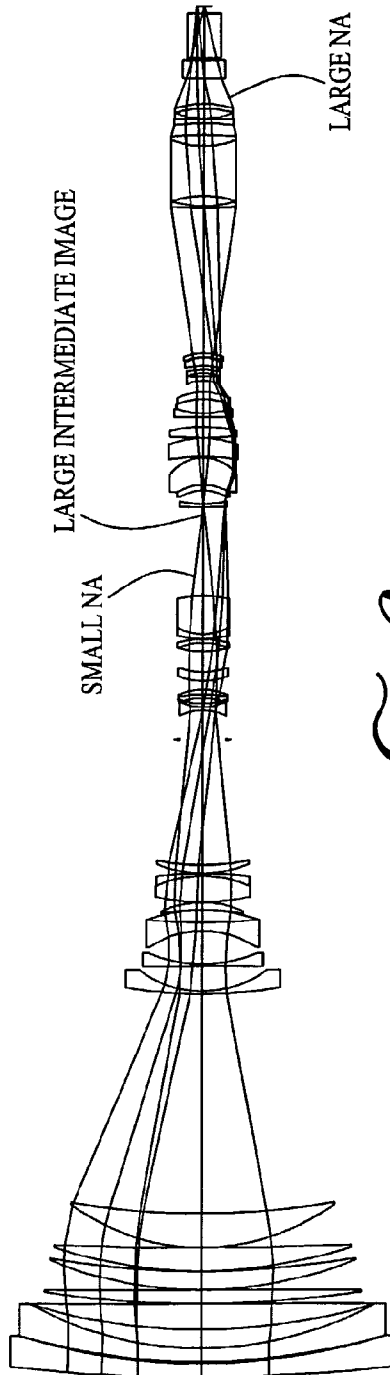
**Panavision, Inc.**

**Patent Attorneys for the Applicant/Nominated Person**

**SPRUSON & FERGUSON**



*FIG. 1*



*FIG. 2*

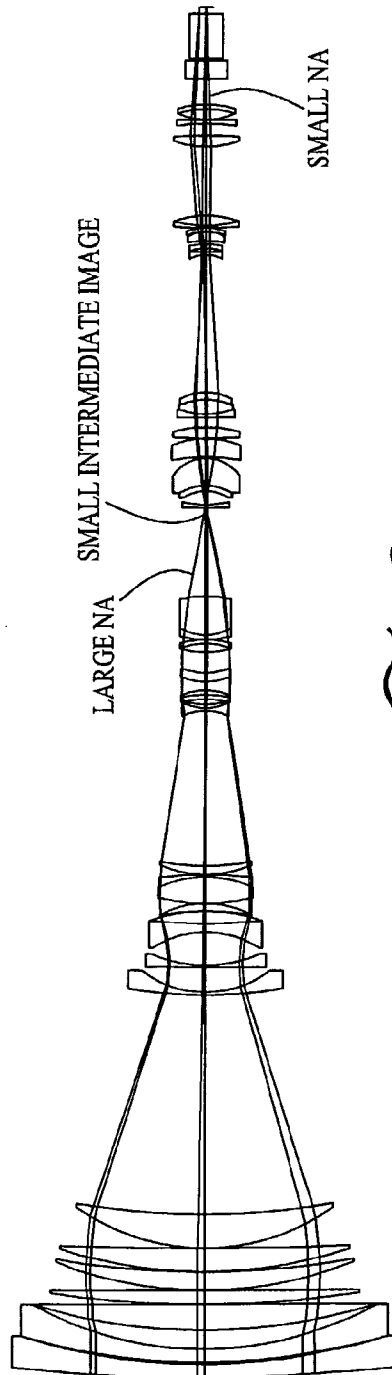
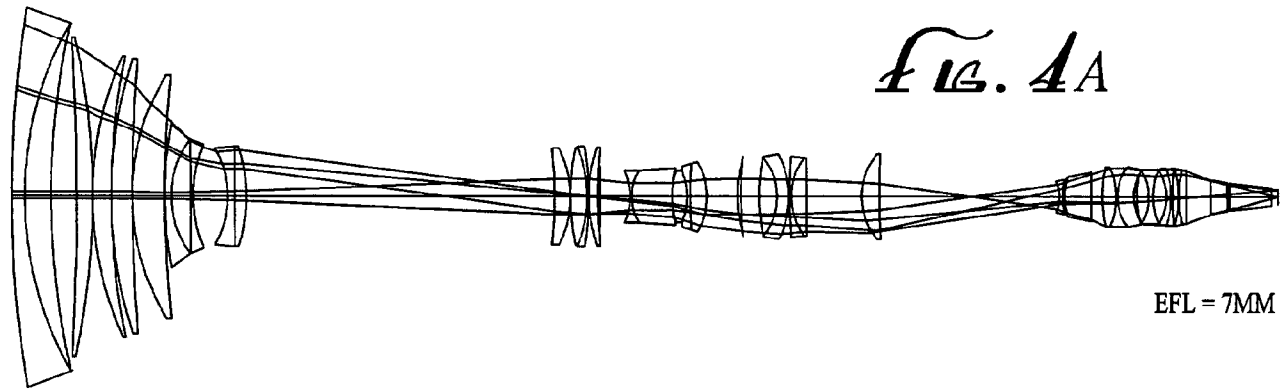


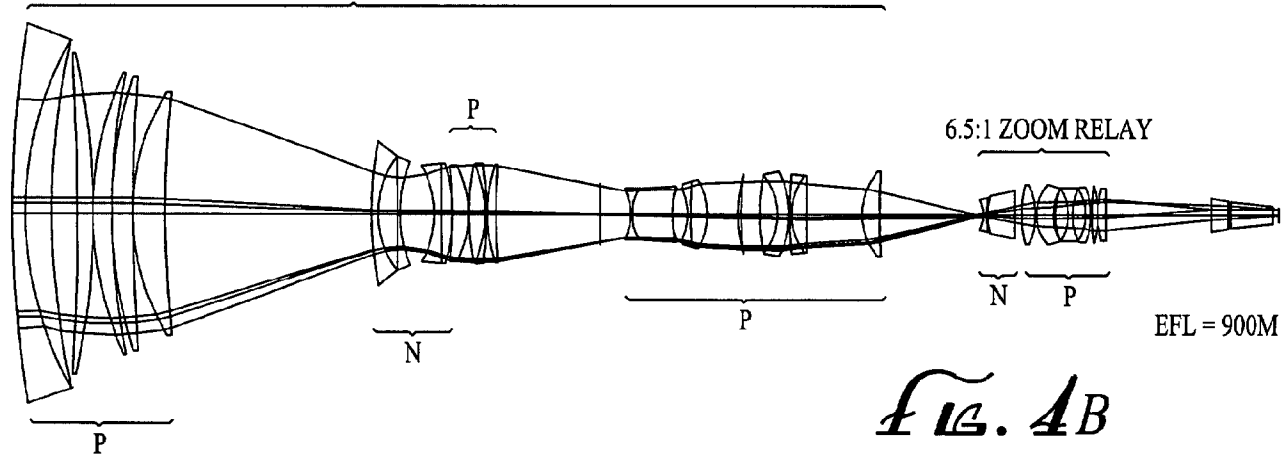
FIG. 3



*Fig. 4A*

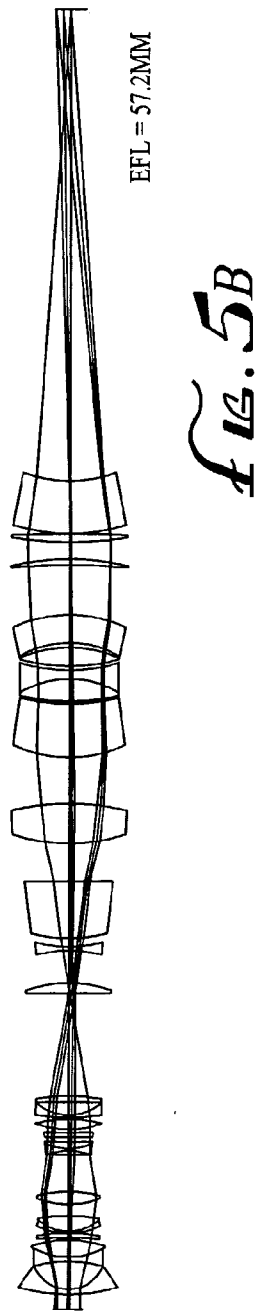
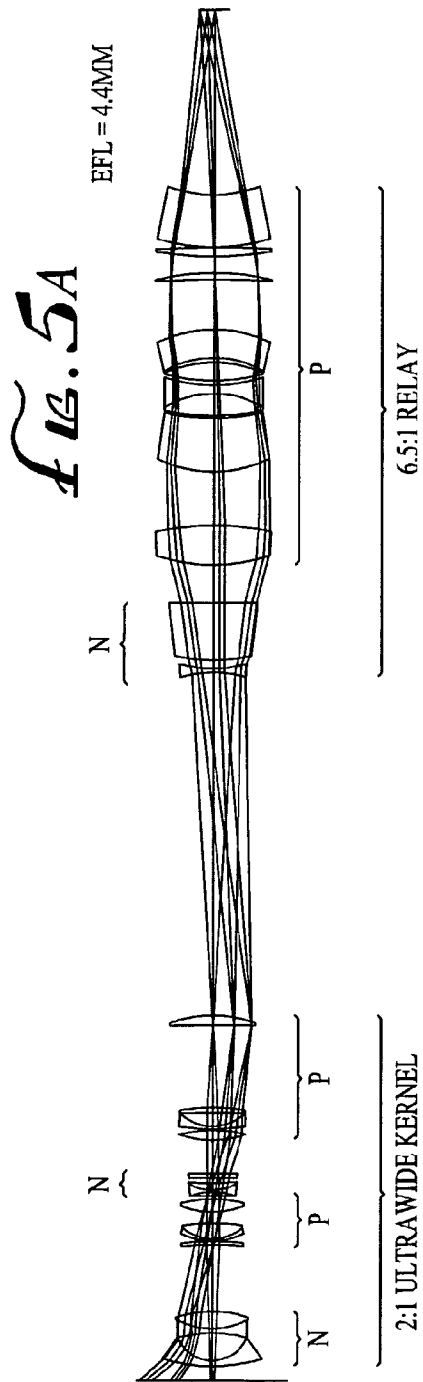
EFL = 7MM

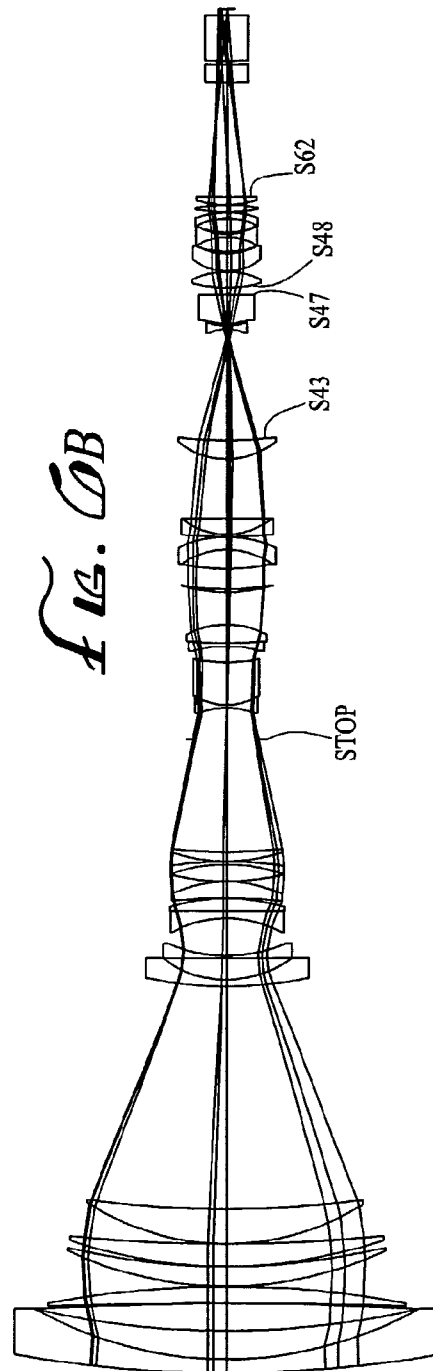
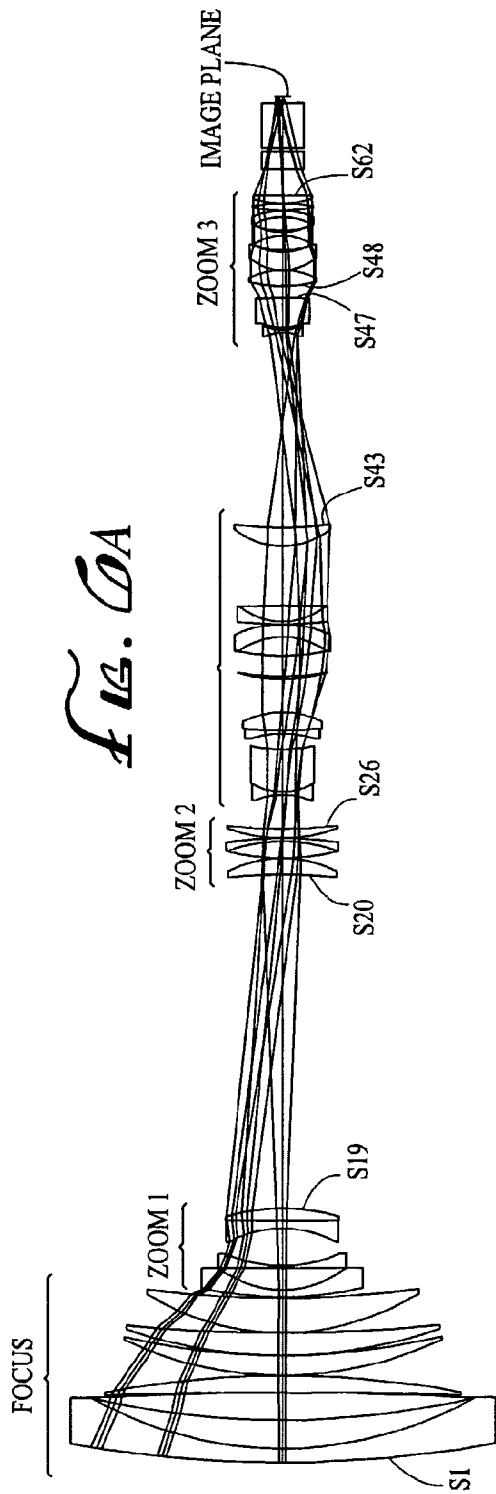
20:1 FRONT ZOOM LENS

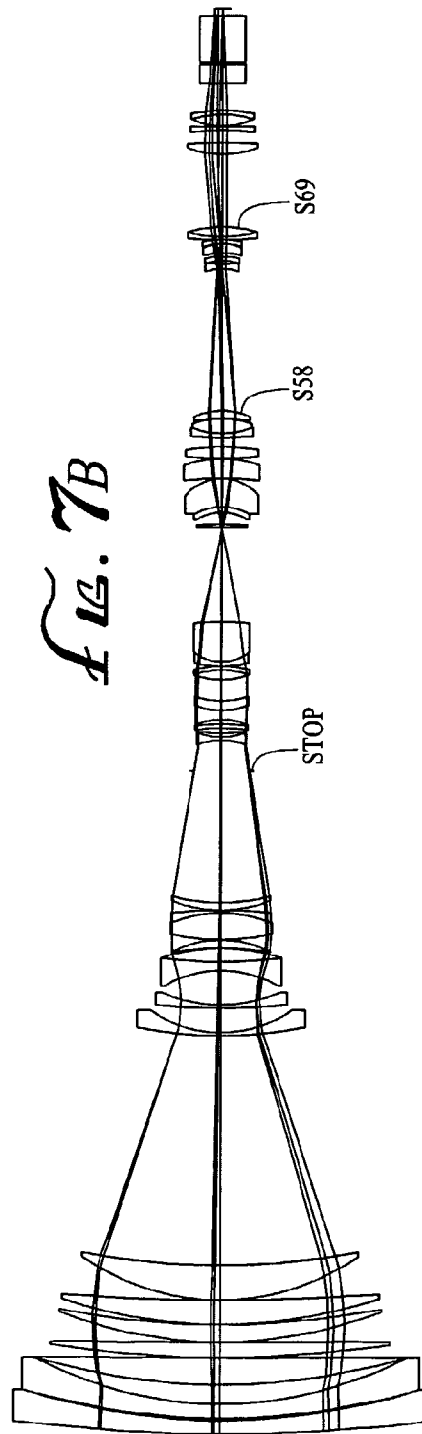
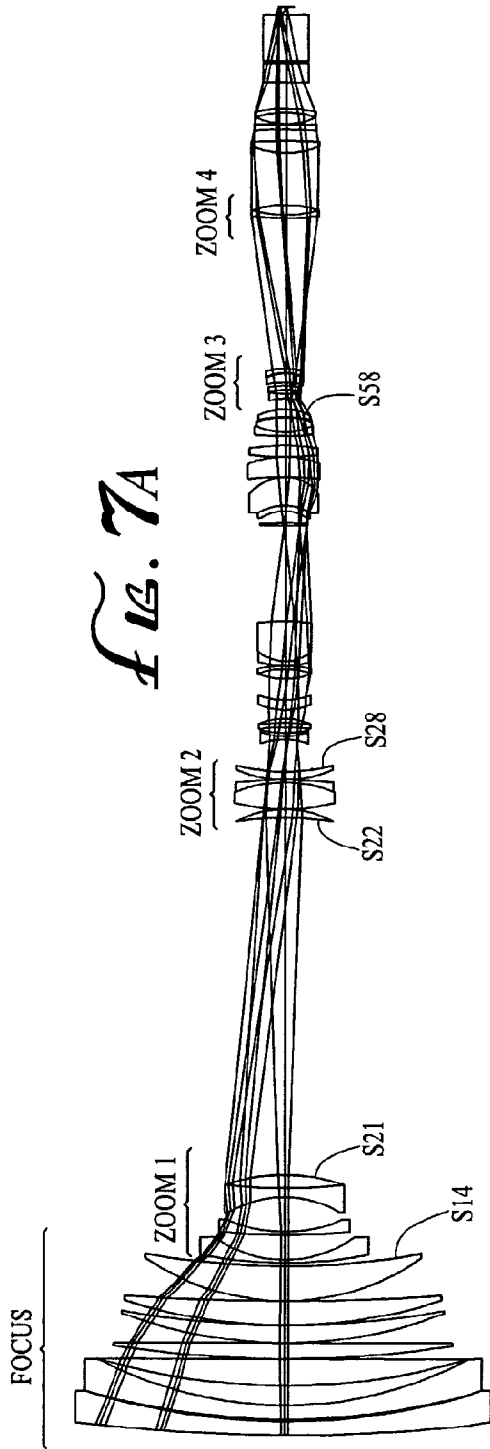


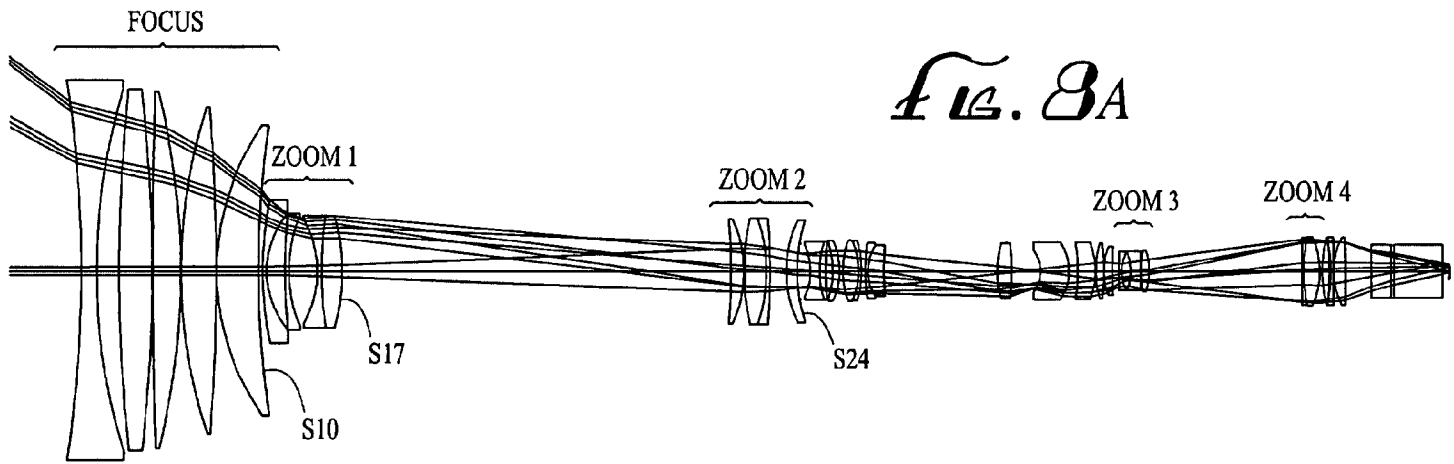
*Fig. 4B*

EFL = 900M

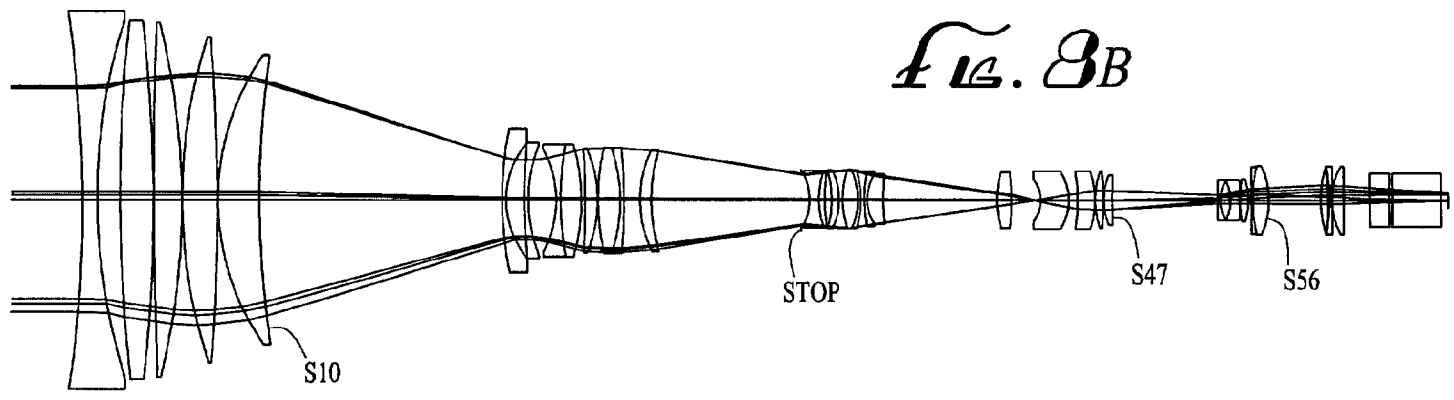




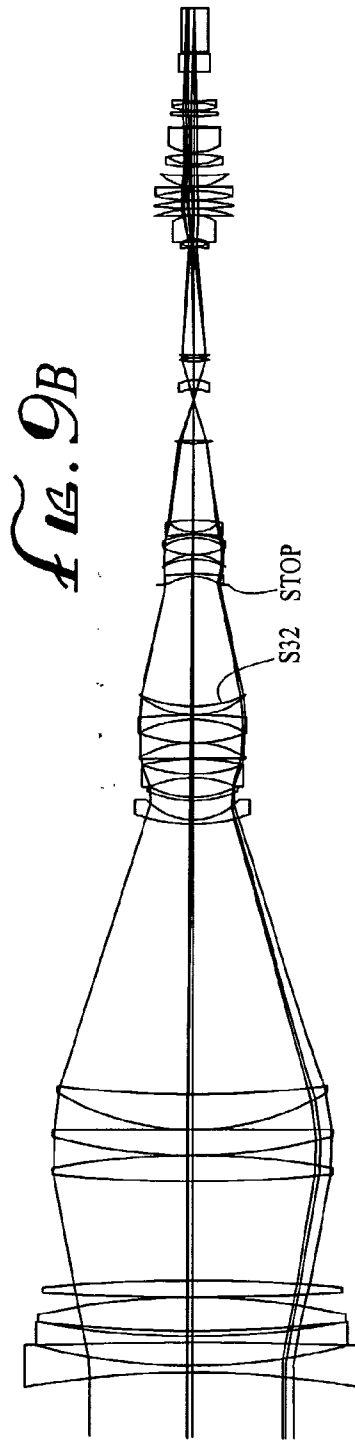
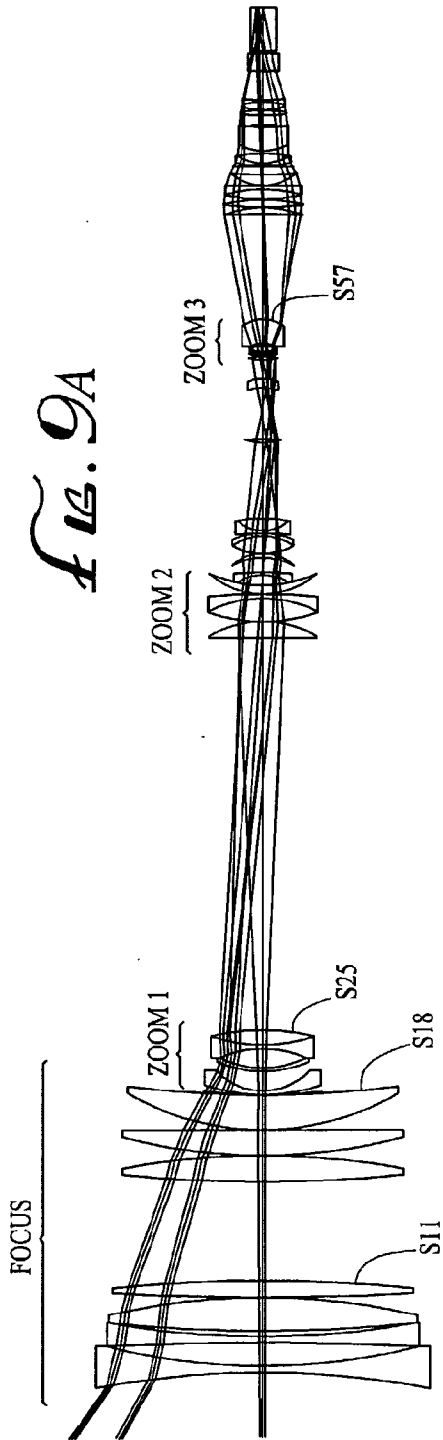


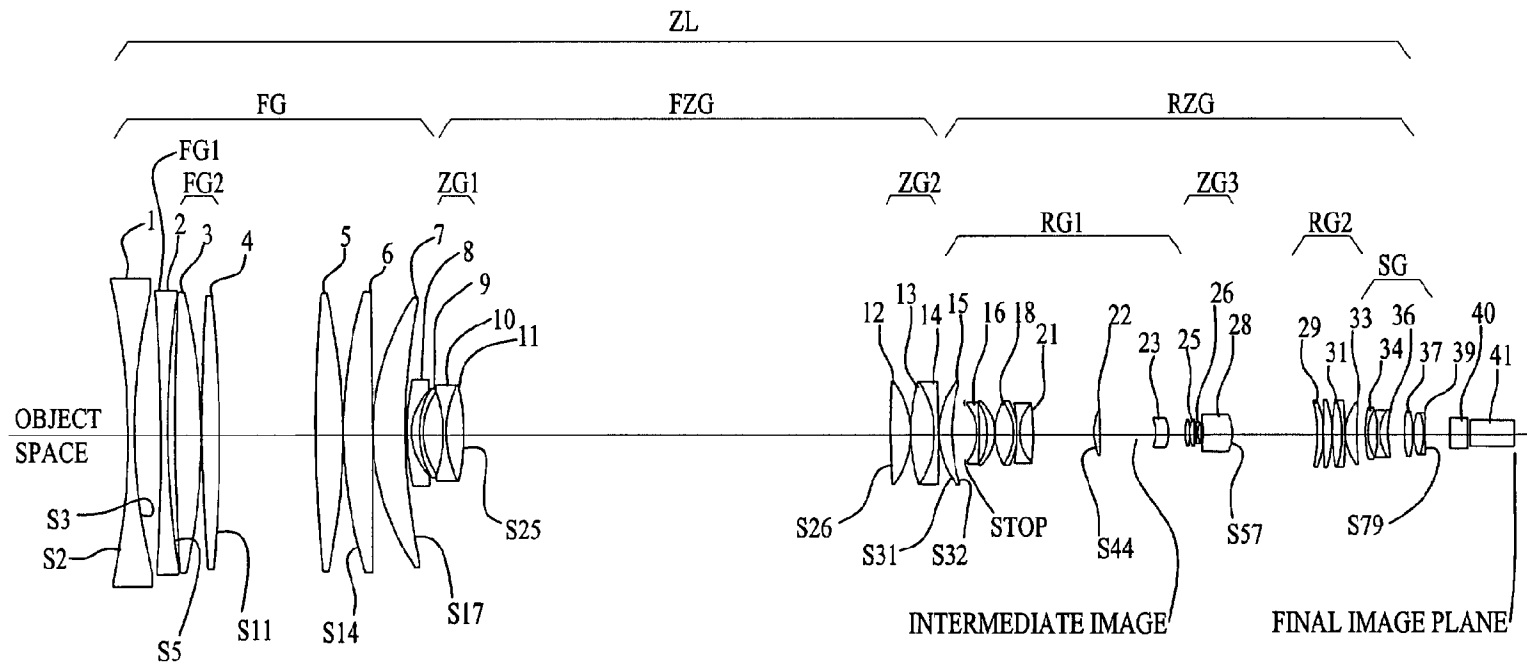


*Fig. 3A*



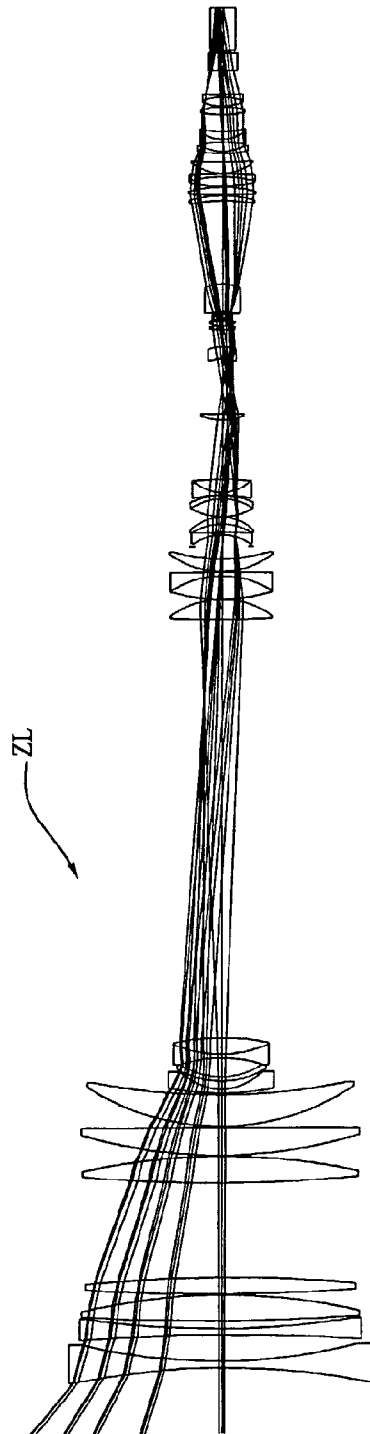
*Fig. 3B*





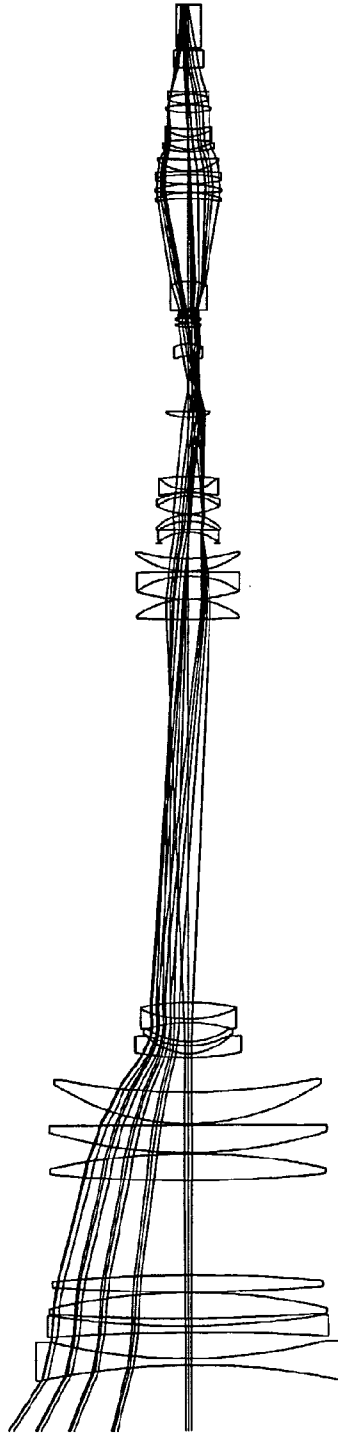
*Fig. 10*

POSITION 1



*FIG. 11*

POSITION 2



*FIG. 12*

POSITION 3

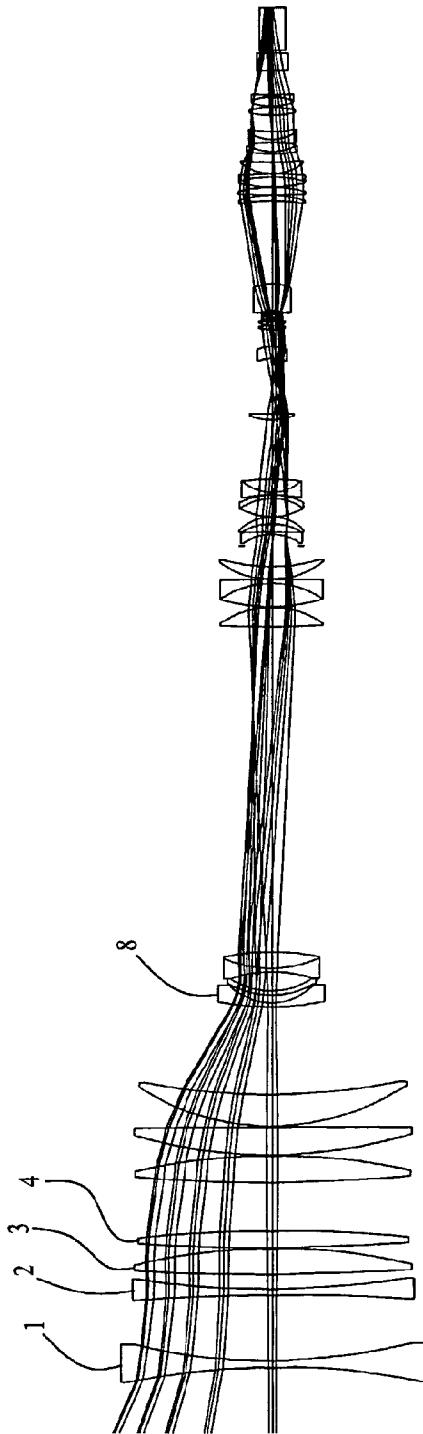


FIG. 13



POSITION 5

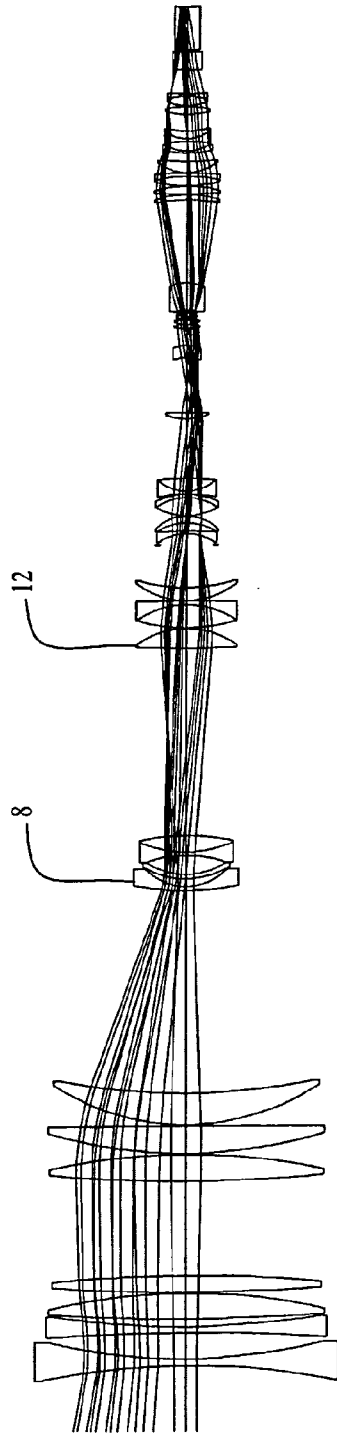


FIG. 15

POSITION 6

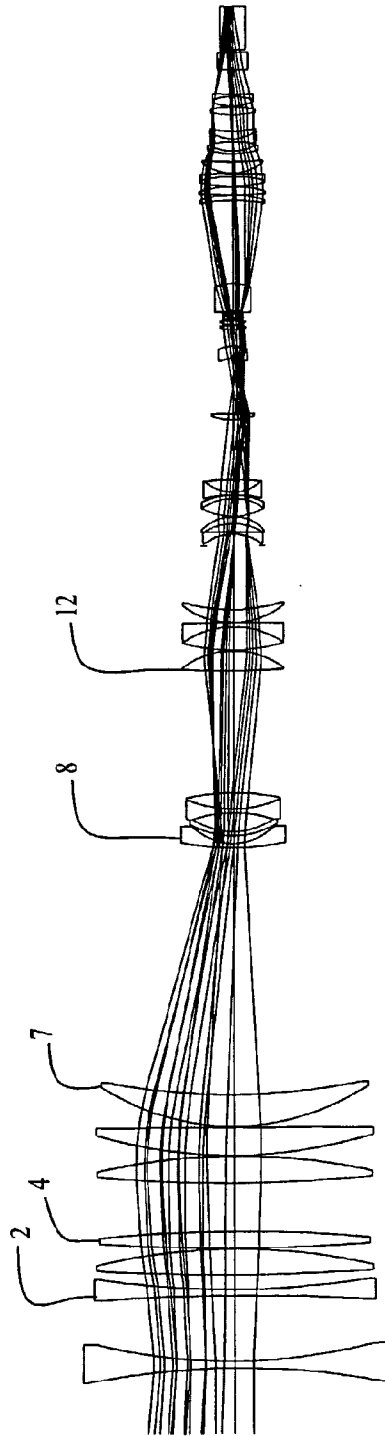


FIG. 10

POSITION 7

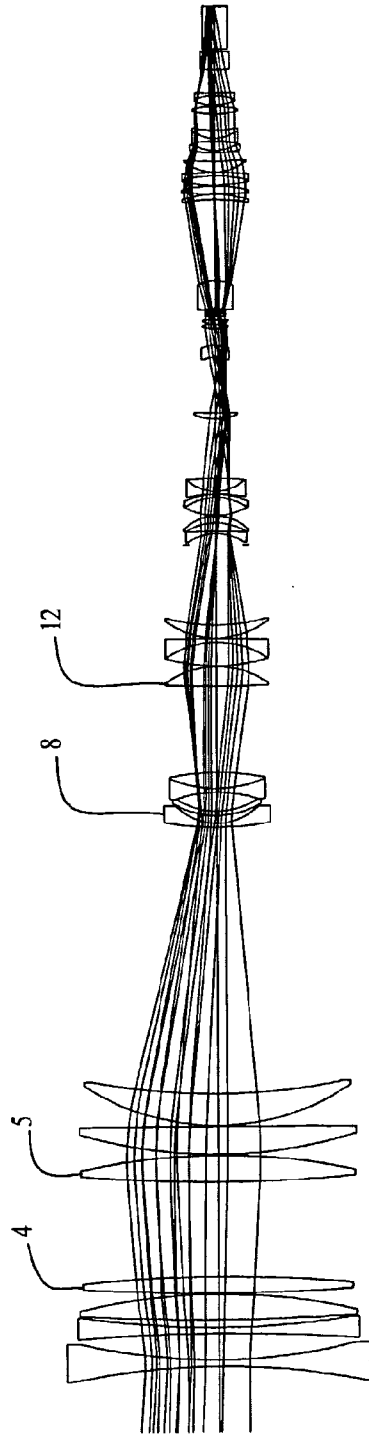


FIG. 17

POSITION 8

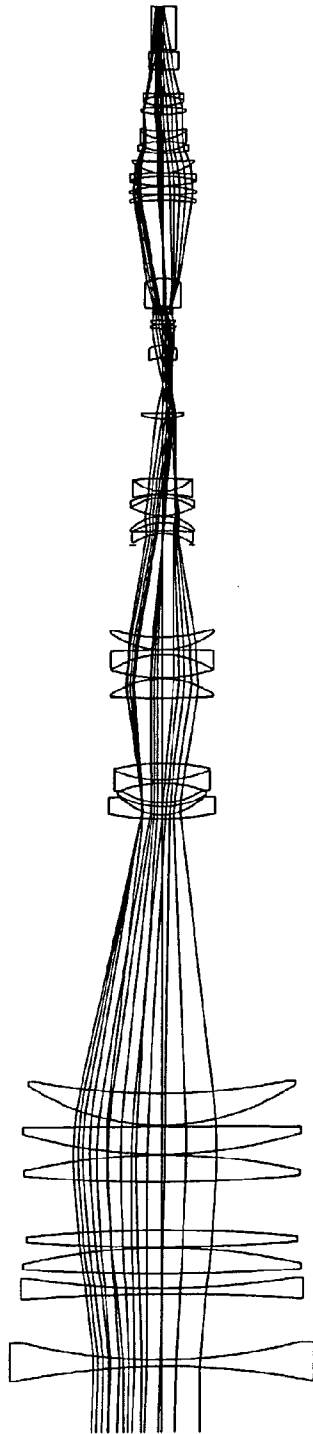


FIG. 18

POSITION 9

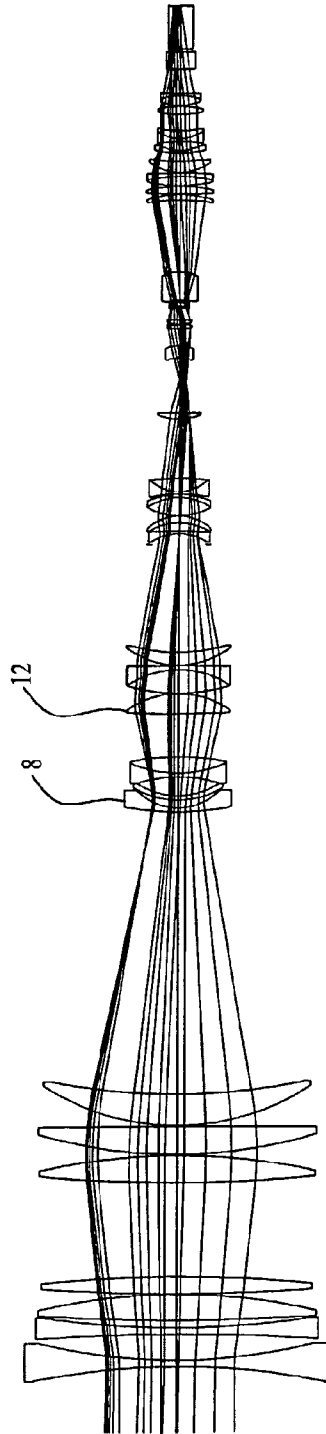


FIG. 19

POSITION 10

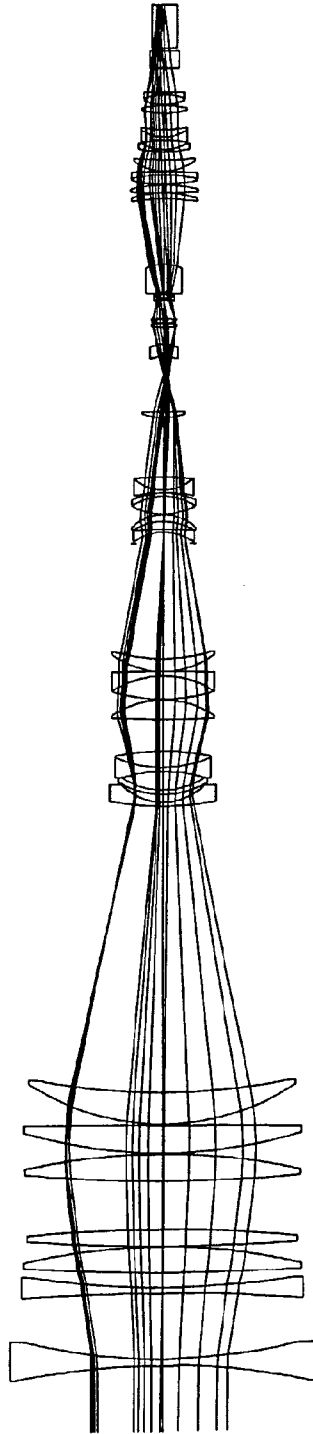
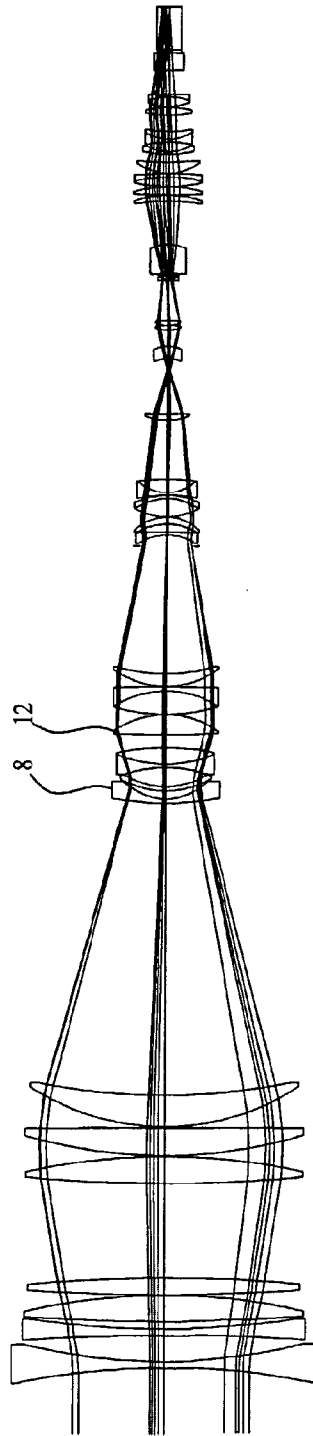


FIG. 20

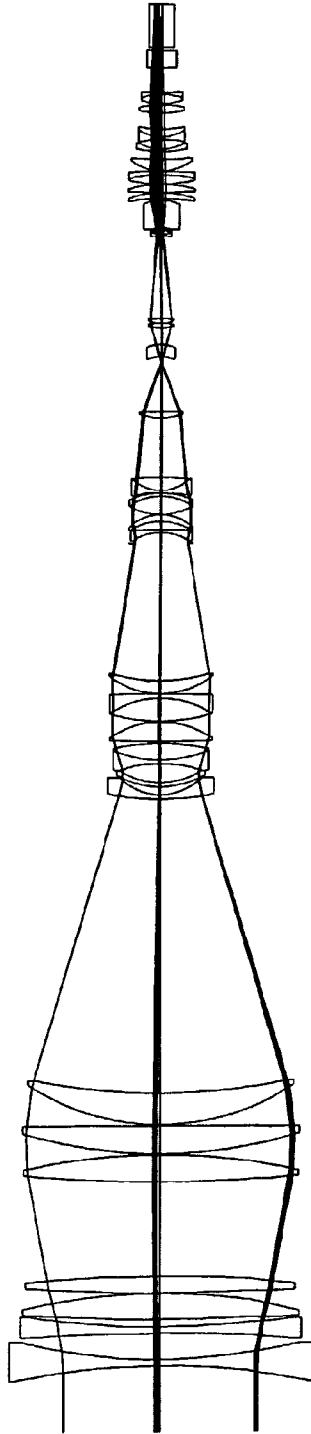
POSITION 11



*FIG. 21*

22/76

POSITION 12



*FIG. 22*



POSITION 14

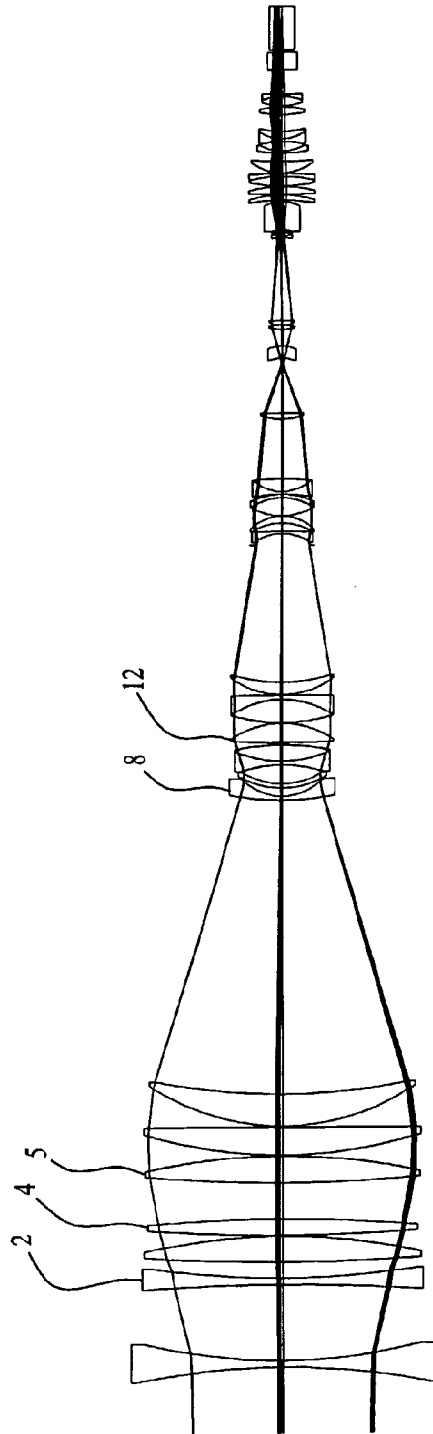


FIG. 2A

POSITION 15

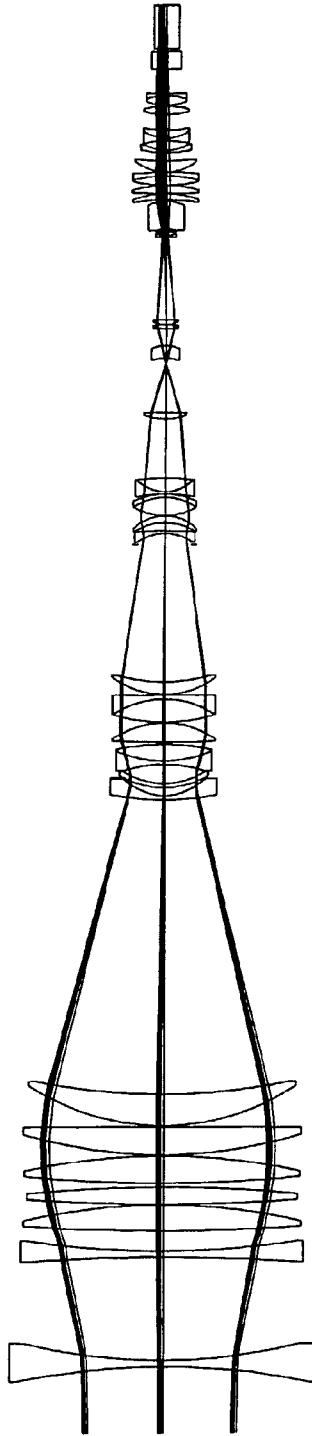


FIG. 25

POSITION 16

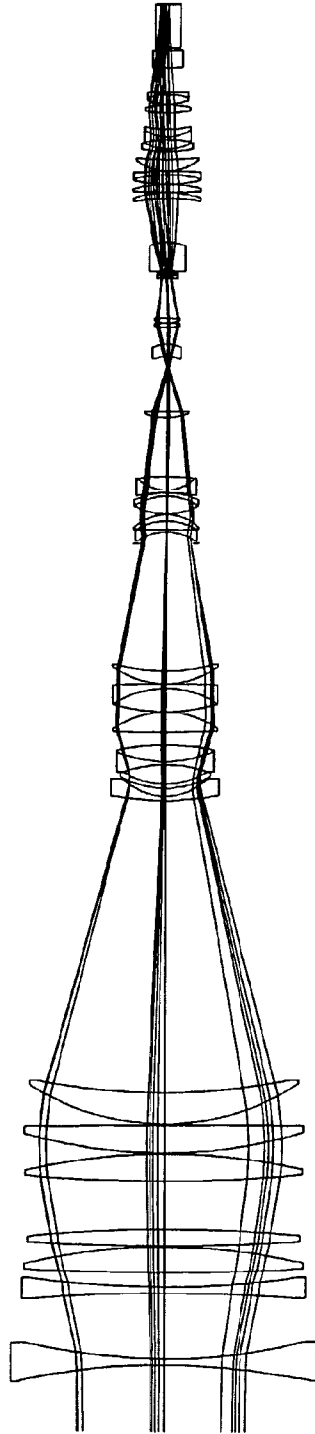


FIG. 20

27/76

POSITION 17

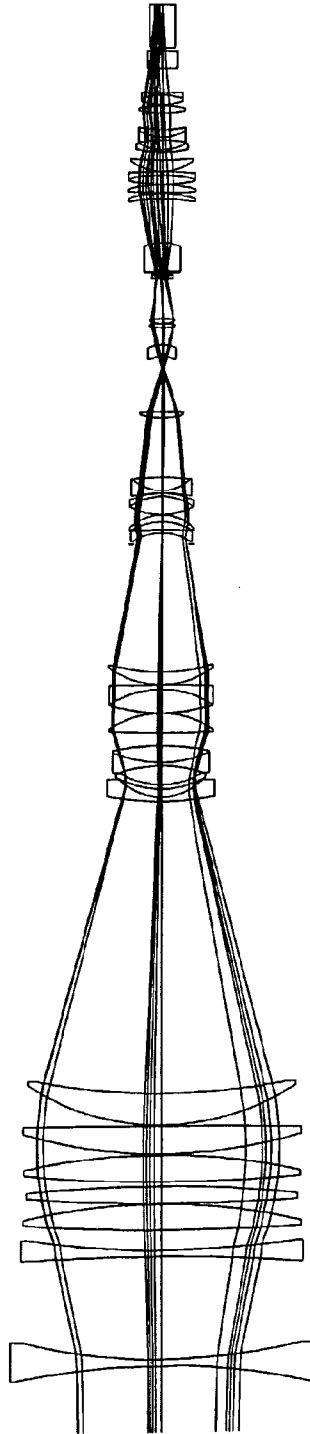


FIG. 27

POSITION 18

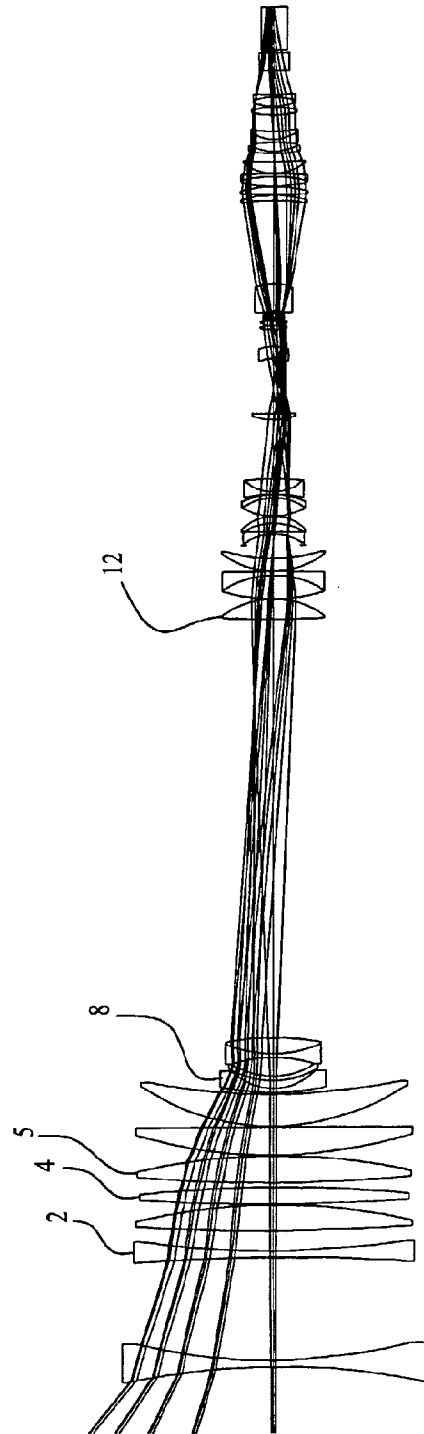


FIG. 28

POSITION 19

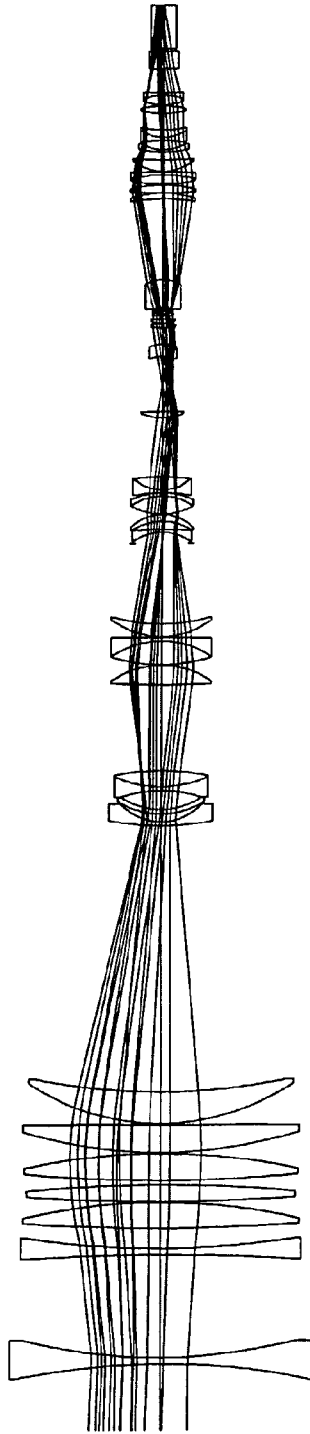


FIG. 29

POSITION 20

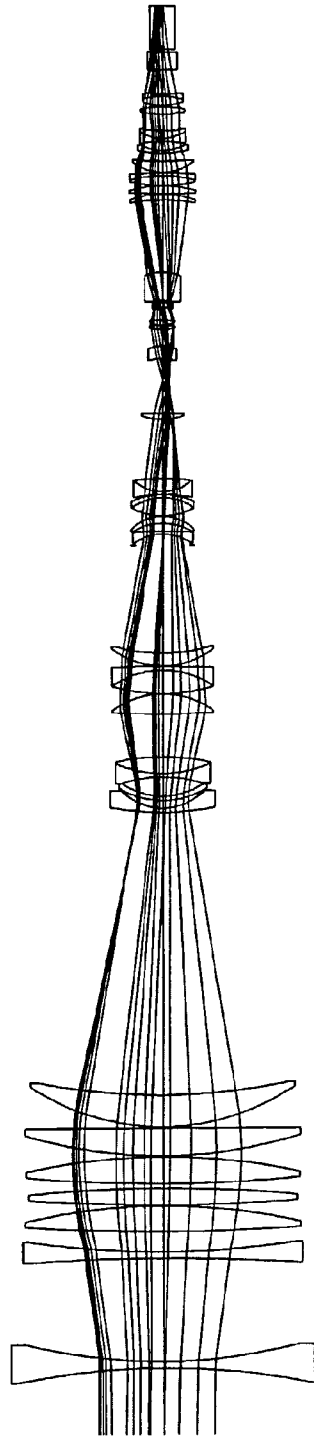
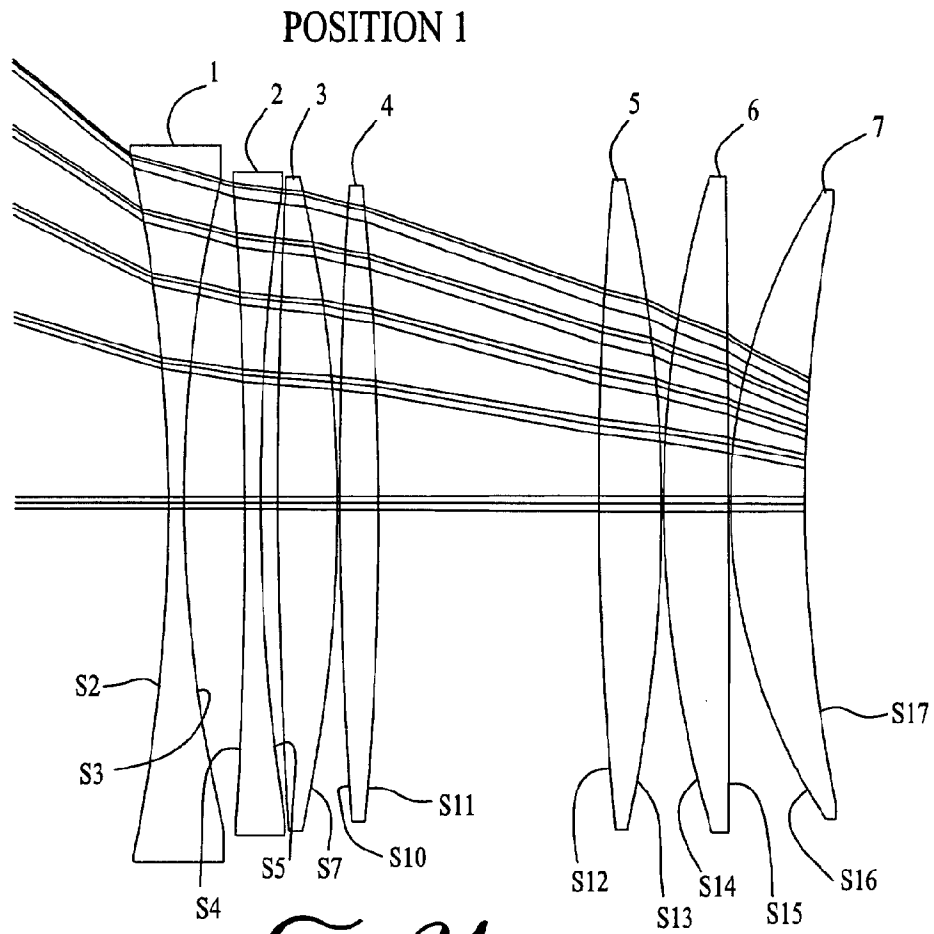
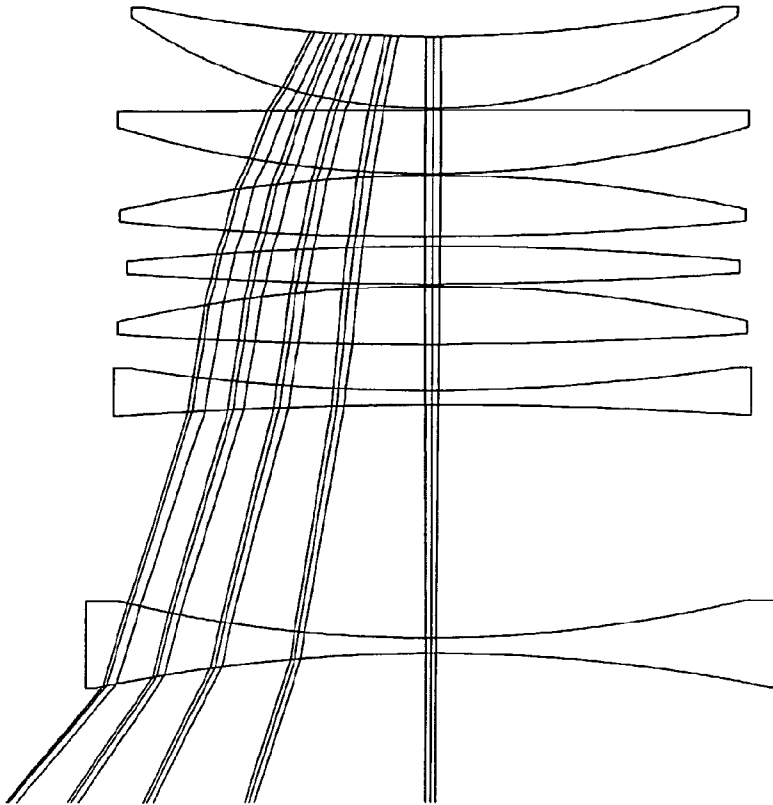


FIG. 30



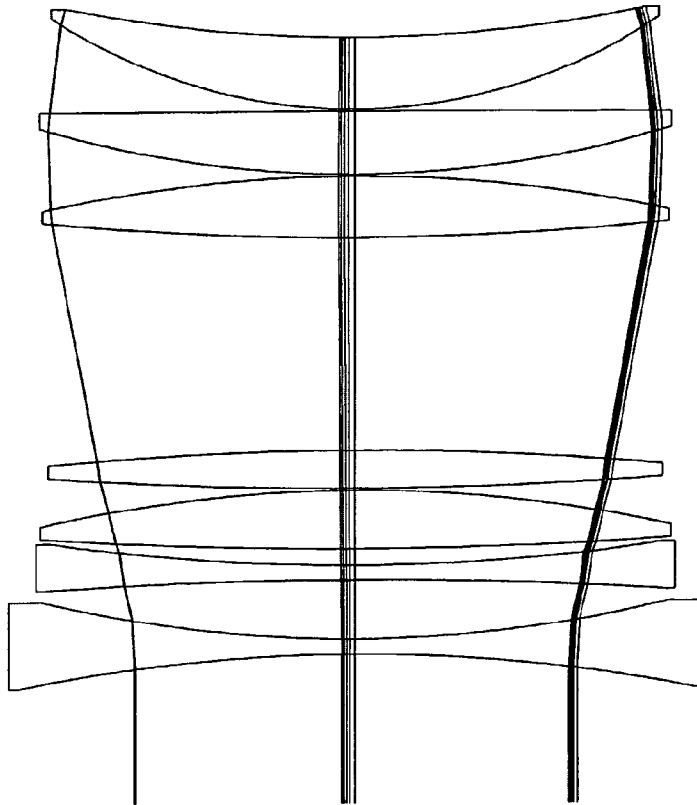
*FIG. 31*

POSITION 18



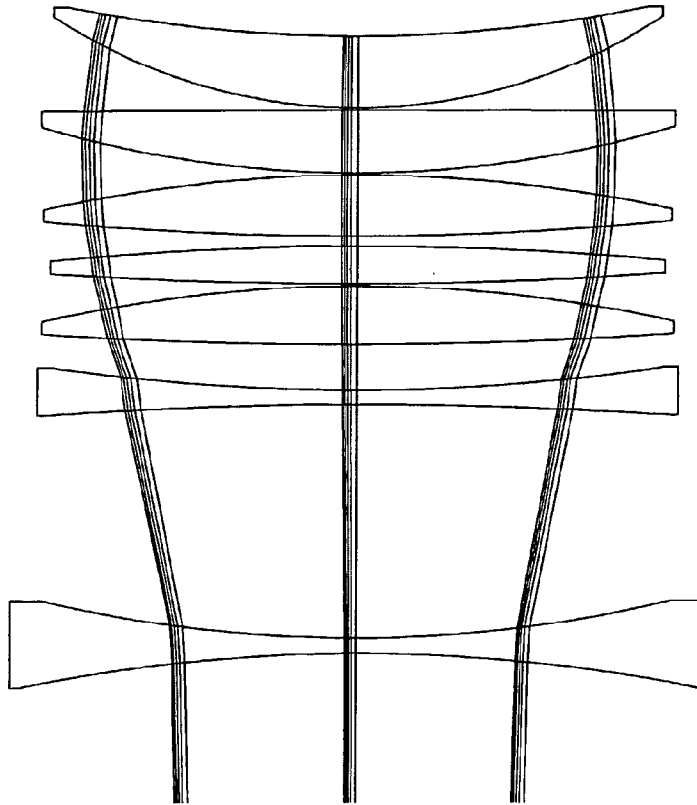
*FIG. 32*

POSITION 12

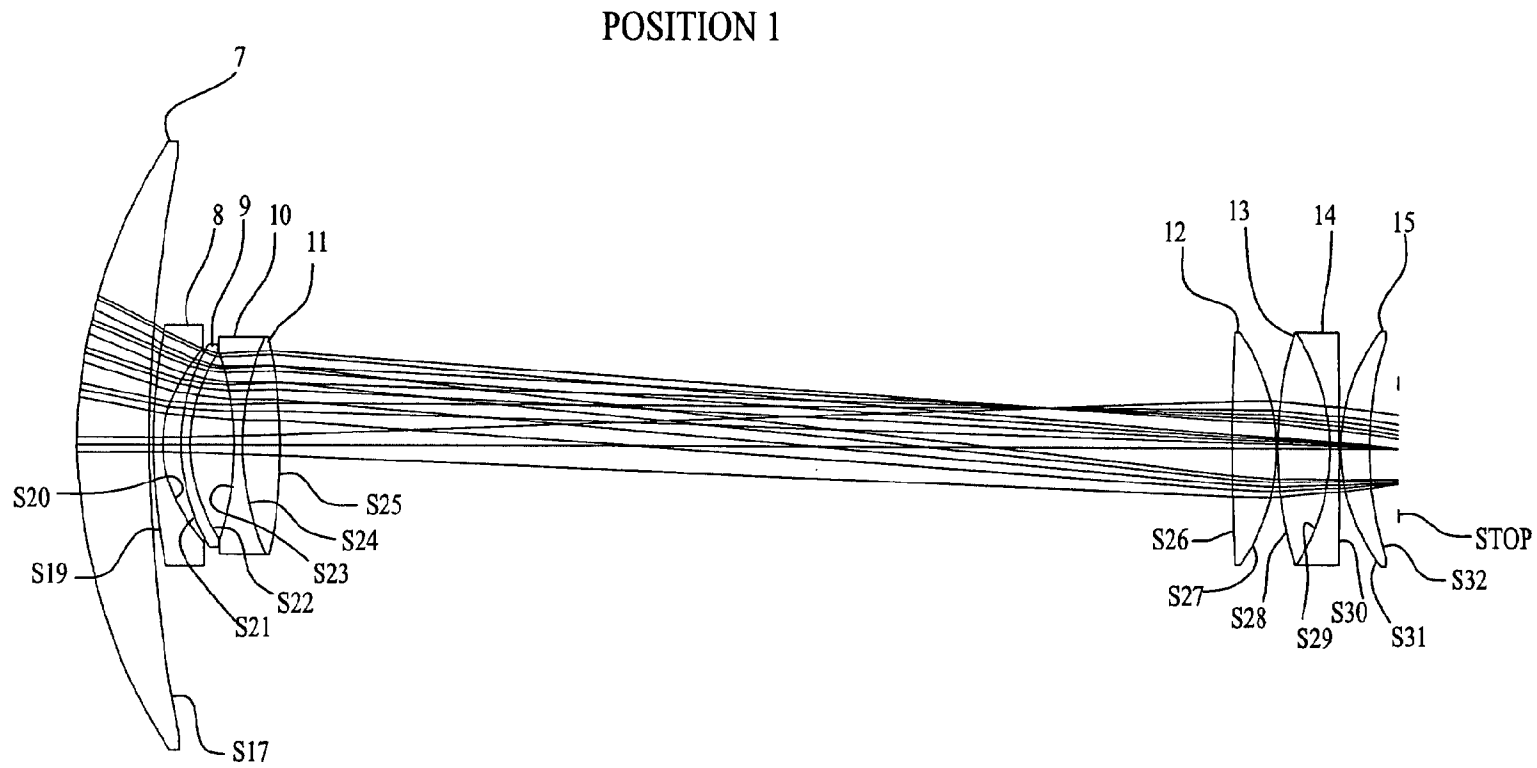


*FIG. 33*

POSITION 15



*FIG. 34*



*FIG. 35*

POSITION 12

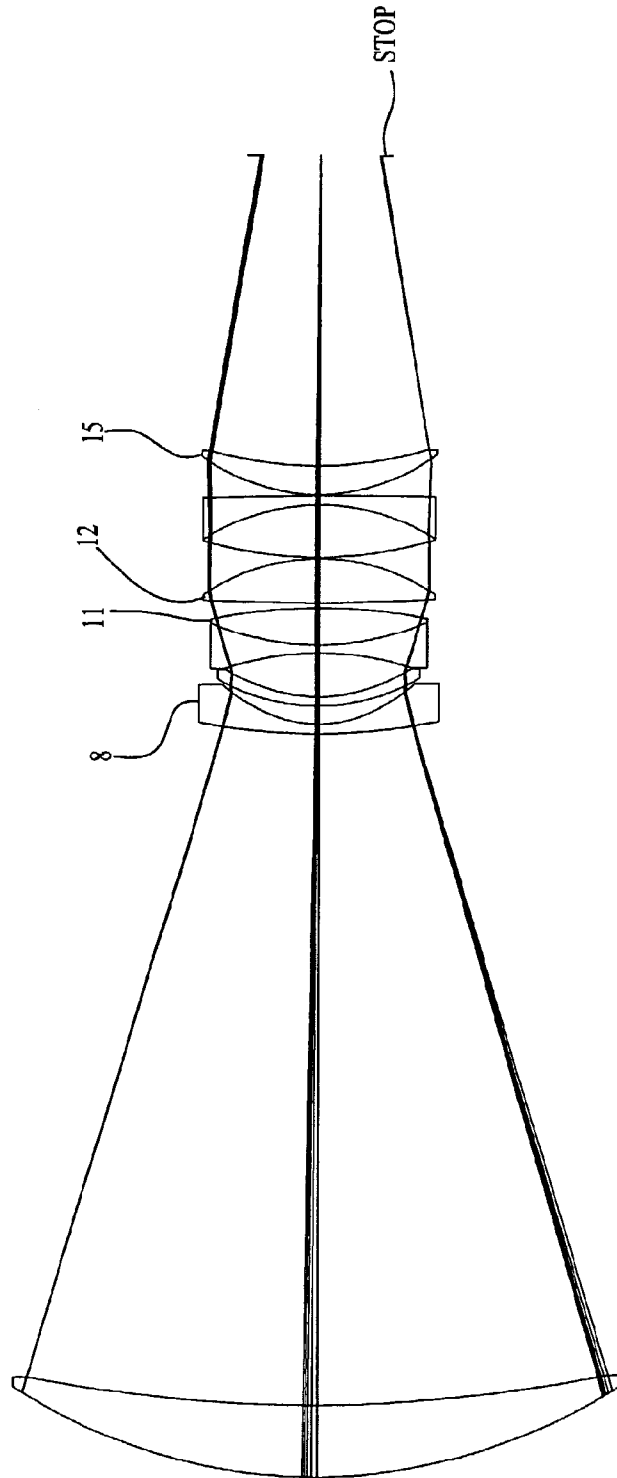
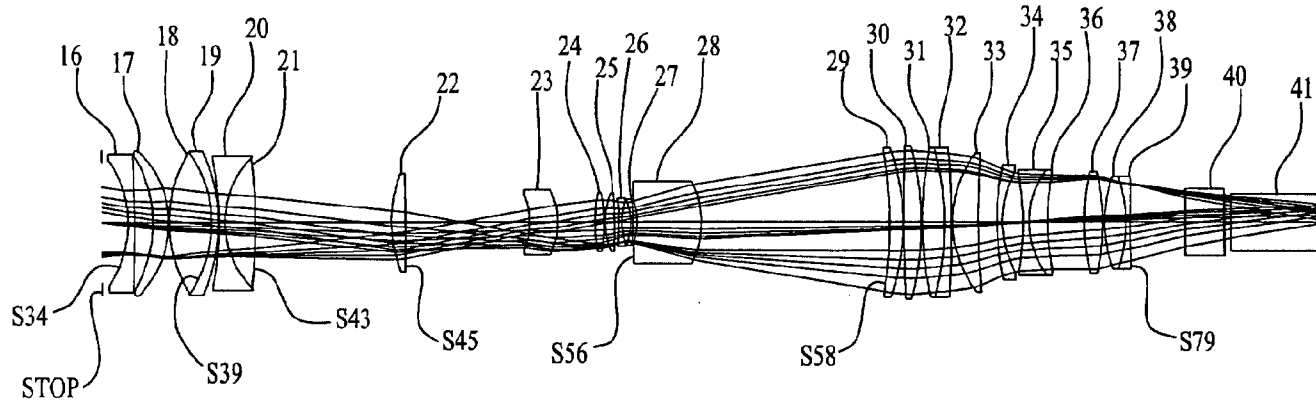


FIG. 30

POSITION 1



37/76

FIG. 37

POSITION 12

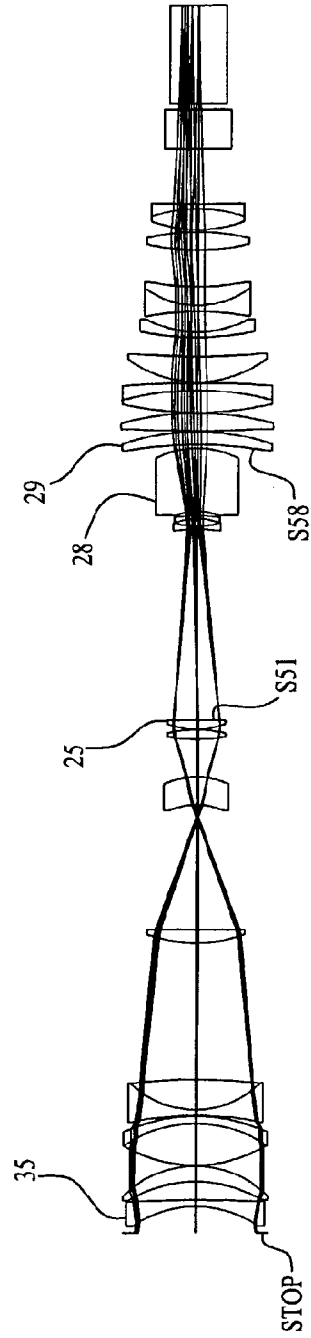
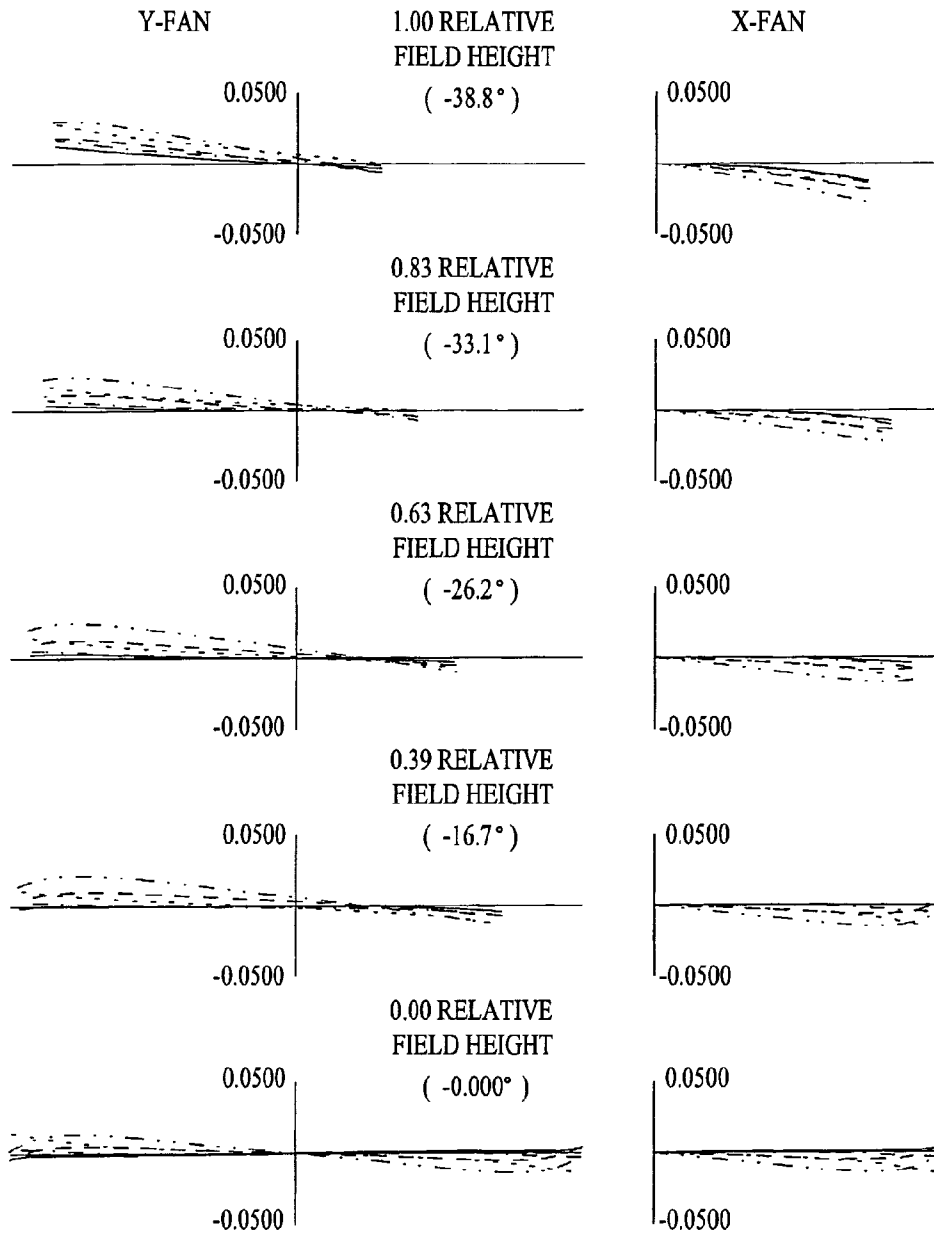
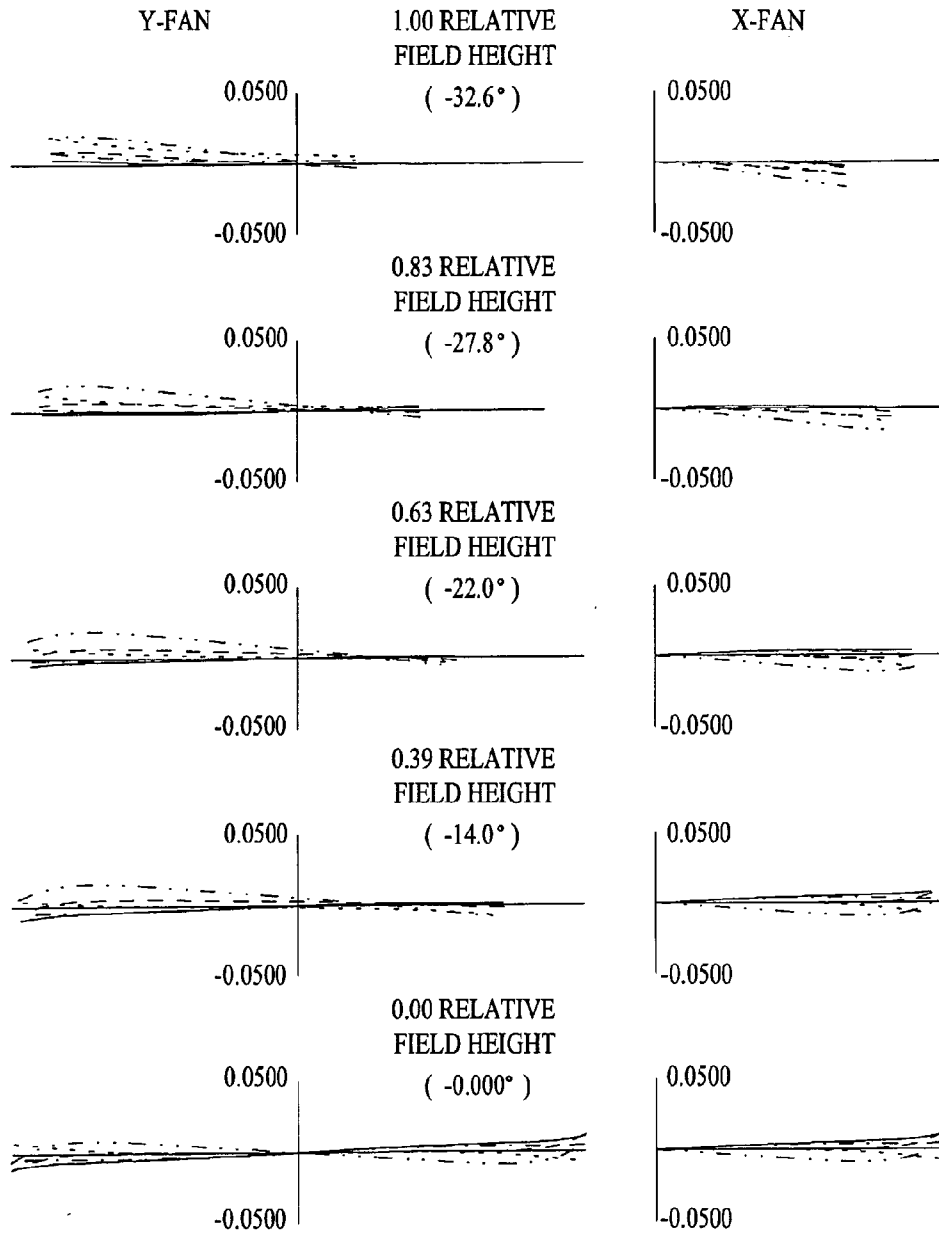


FIG. 38

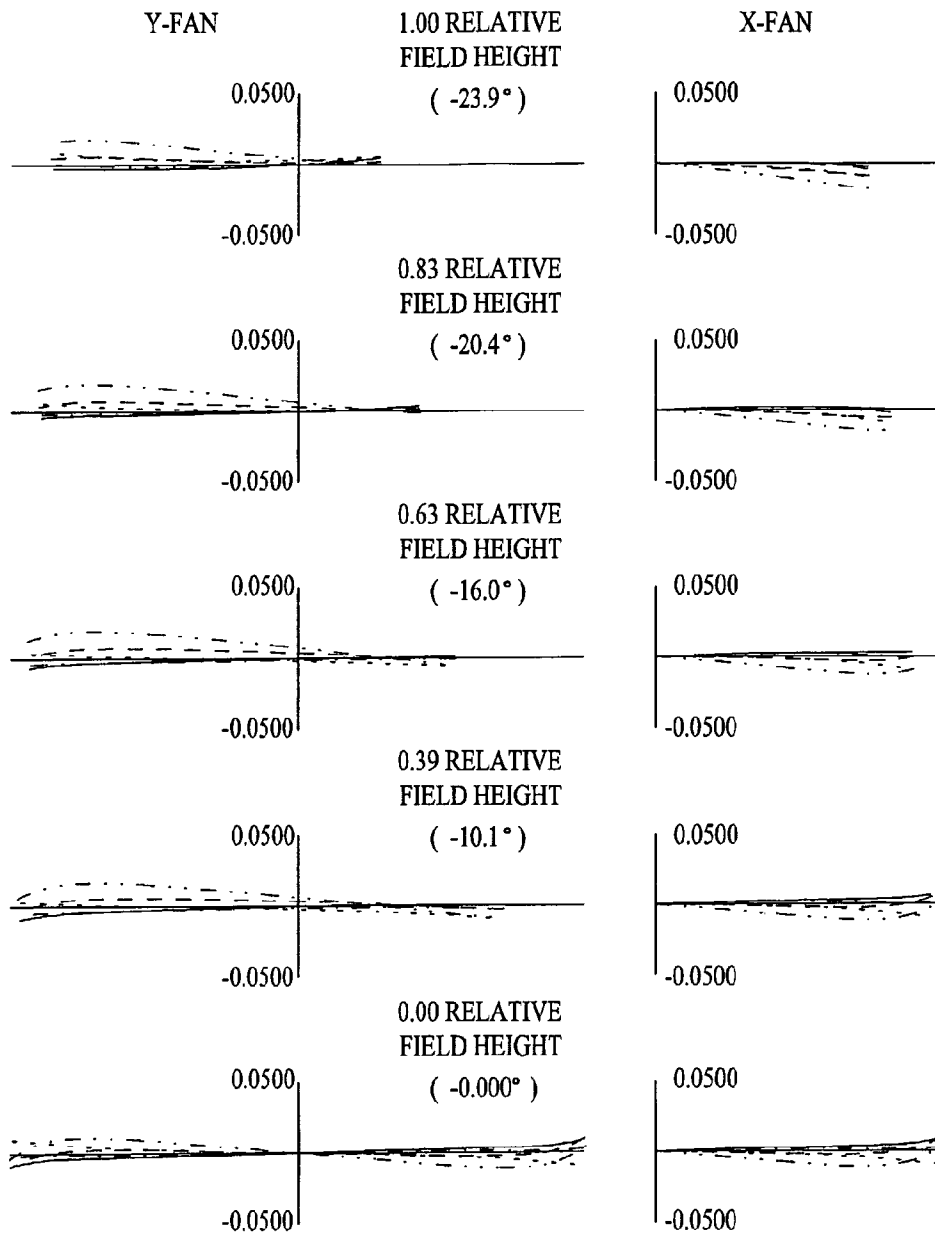


<p><i>Fig. 39</i></p> <p>RAY ABERRATIONS (MILLIMETERS)</p> <p>POSITION 1</p>	<p>----- 643.8469 NM</p> <p>----- 587.5600 NM</p> <p>----- 546.0700 NM</p> <p>----- 486.1300 NM</p> <p>----- 460.0000 NM</p>
------------------------------------------------------------------------------	------------------------------------------------------------------------------------------------------------------------------

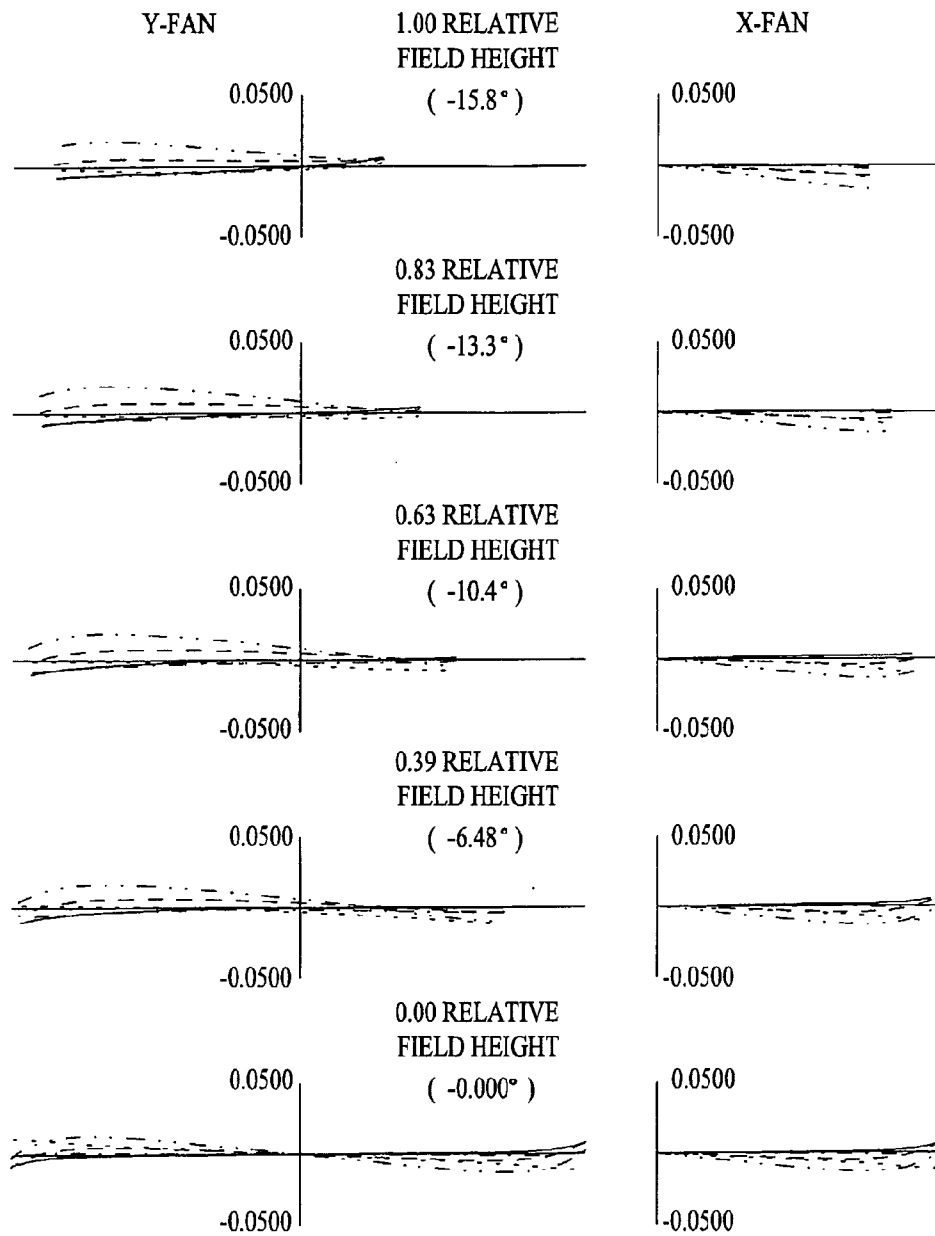
40/76



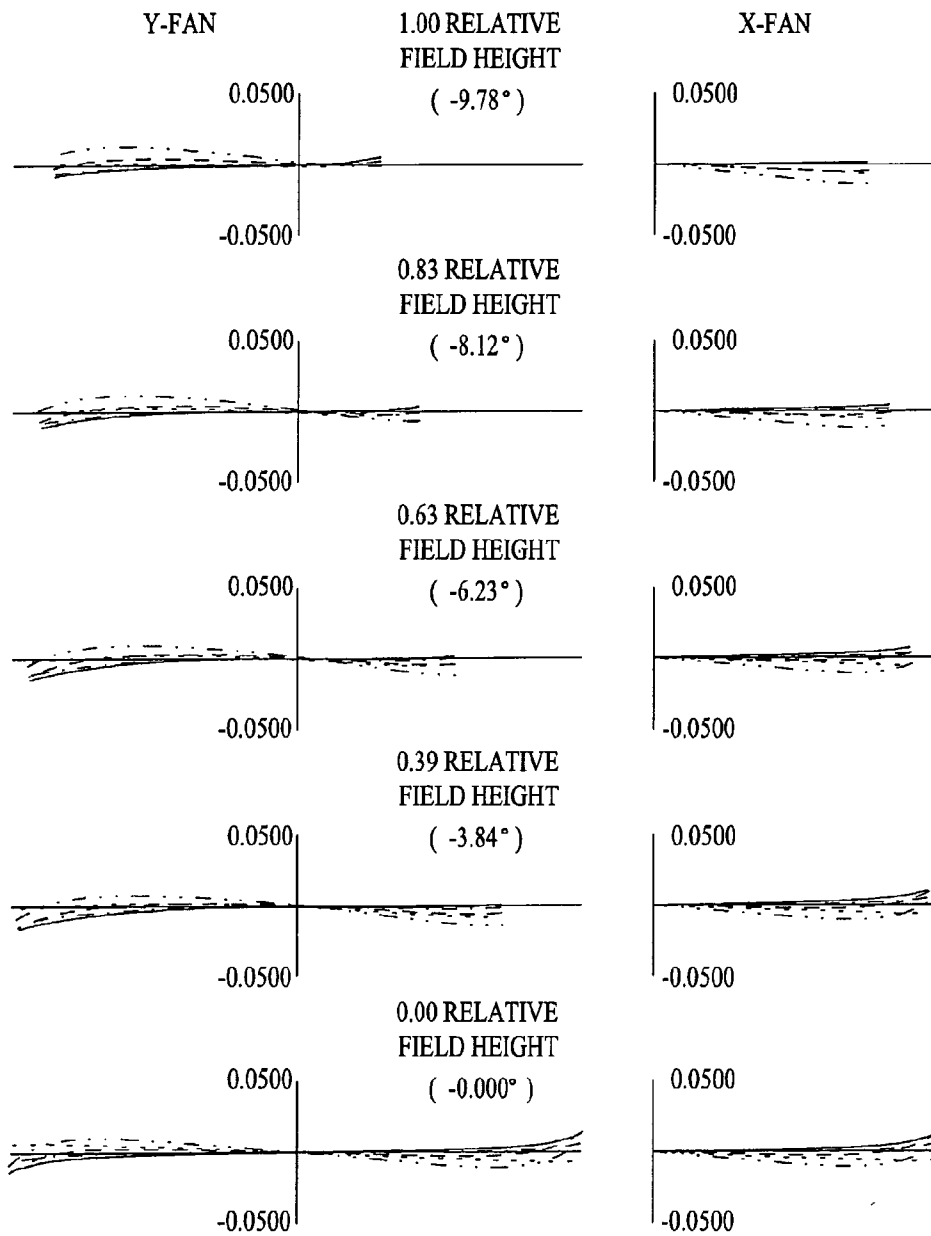
<p><i>FIG. 40</i></p> <p>RAY ABERRATIONS (MILLIMETERS)</p> <p>POSITION 2</p>	<p>----- 643.8469 NM</p> <p>----- 587.5600 NM</p> <p>----- 546.0700 NM</p> <p>----- 486.1300 NM</p> <p>----- 460.0000 NM</p>
------------------------------------------------------------------------------	------------------------------------------------------------------------------------------------------------------------------



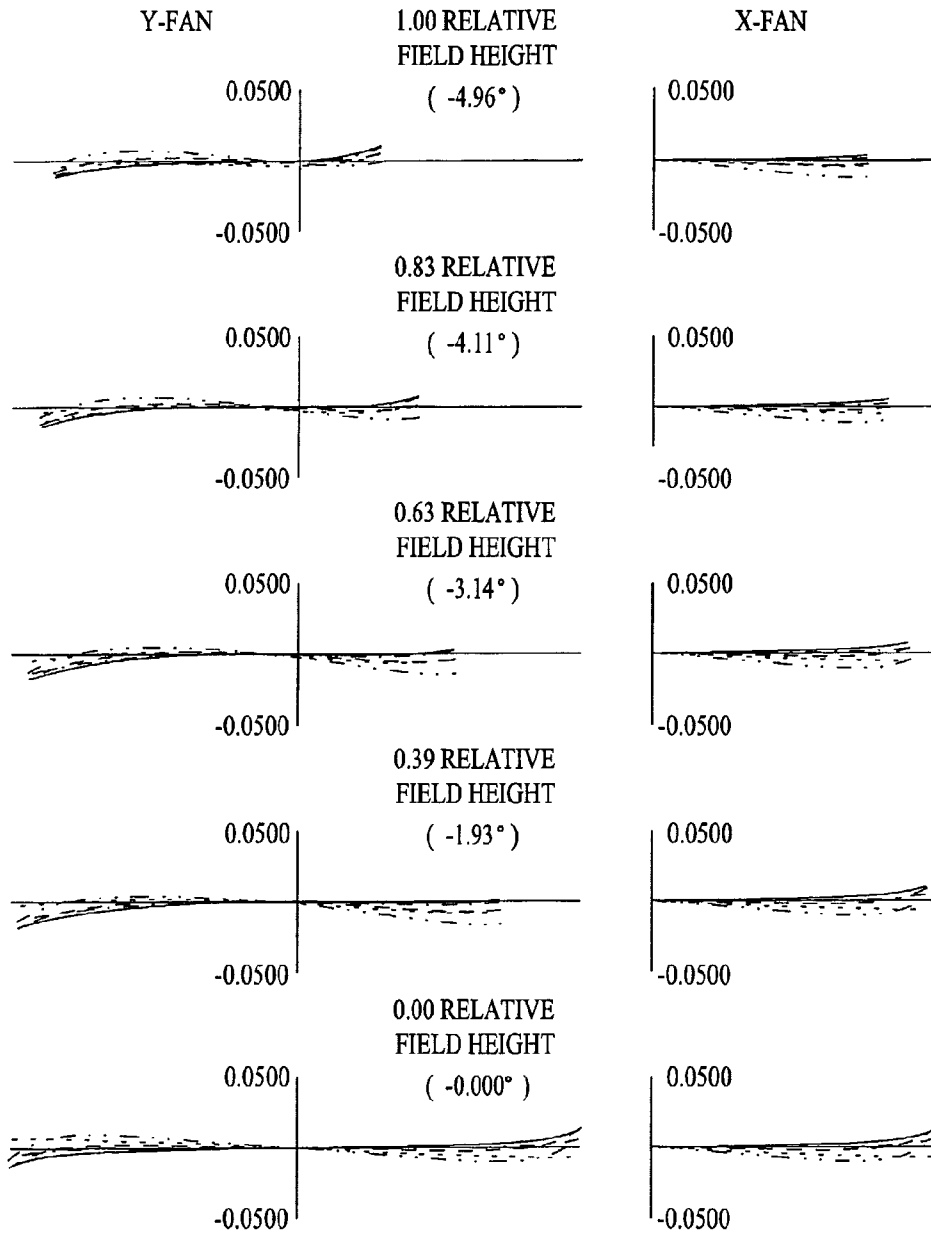
<p><i>Fig. 41</i></p> <p>RAY ABERRATIONS (MILLIMETERS)</p> <p>POSITION 3</p>	<p>----- 643.8469 NM</p> <p>----- 587.5600 NM</p> <p>----- 546.0700 NM</p> <p>----- 486.1300 NM</p> <p>----- 460.0000 NM</p>
------------------------------------------------------------------------------	------------------------------------------------------------------------------------------------------------------------------



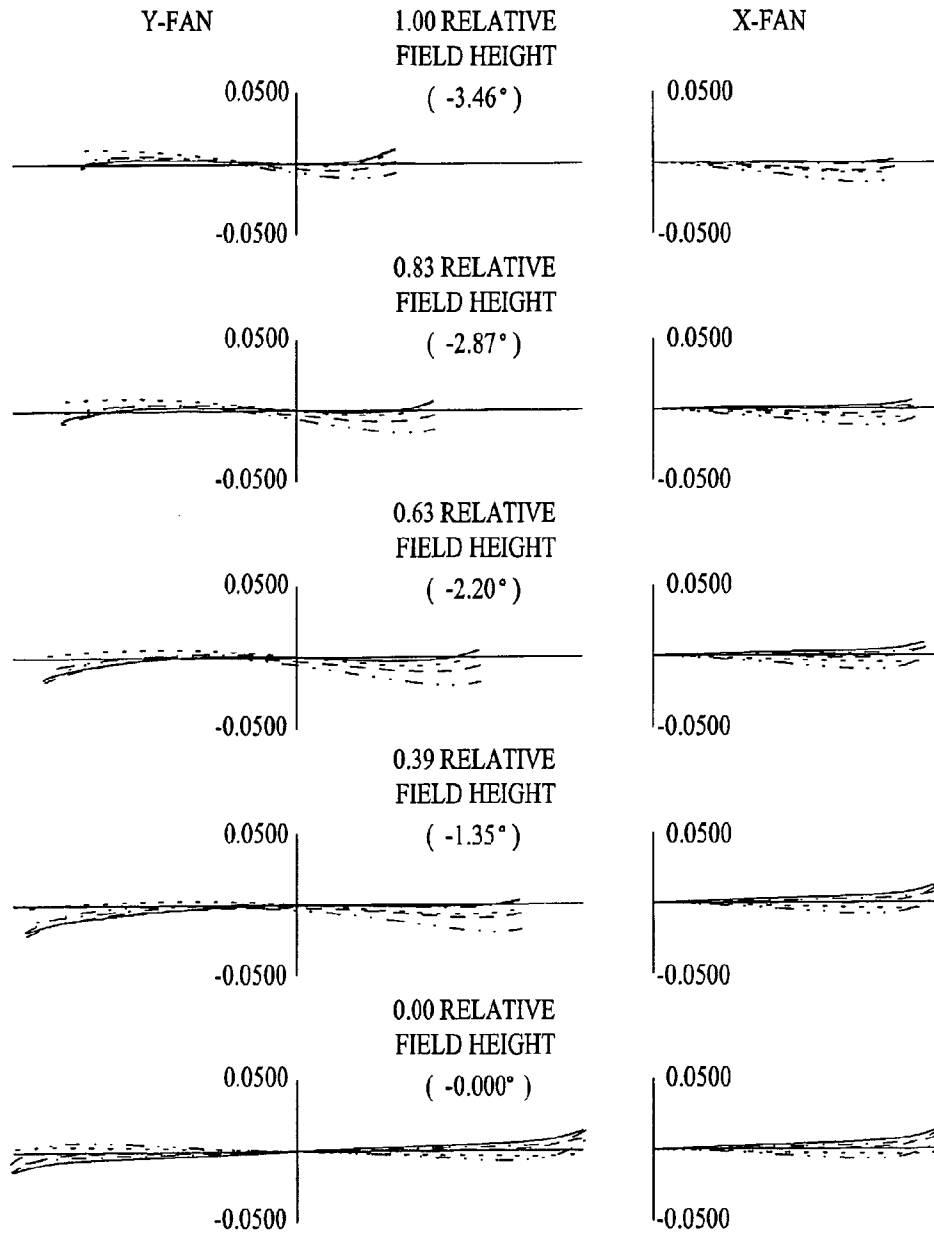
<p><i>Fig. 42</i></p> <p>RAY ABERRATIONS (MILLIMETERS)</p> <p>POSITION 4</p>	<p>----- 643.8469 NM</p> <p>----- 587.5600 NM</p> <p>----- 546.0700 NM</p> <p>----- 486.1300 NM</p> <p>----- 460.0000 NM</p>
------------------------------------------------------------------------------	------------------------------------------------------------------------------------------------------------------------------



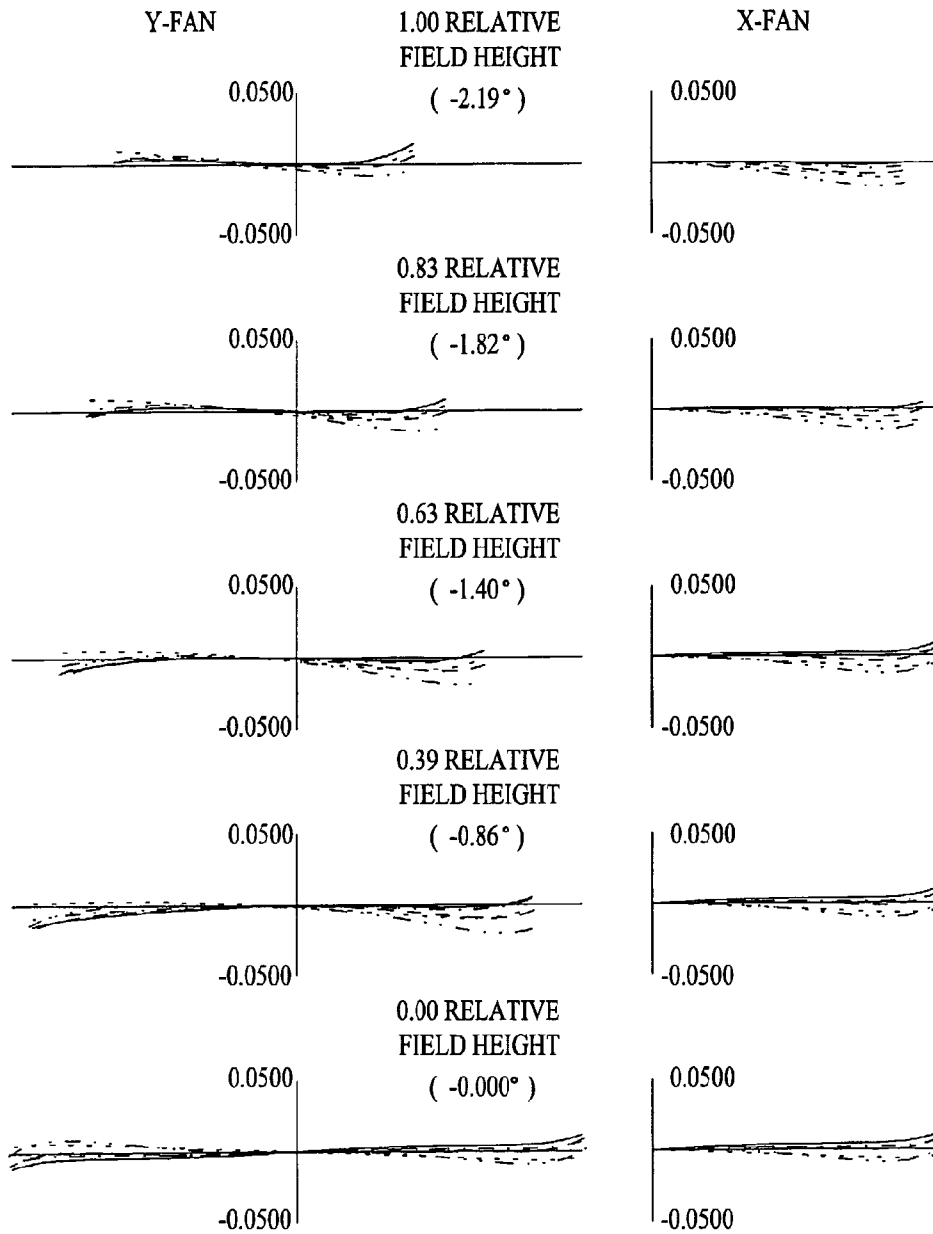
<p><i>Fig. 43</i></p> <p>RAY ABERRATIONS (MILLIMETERS)</p> <p>POSITION 5</p>	<p>----- 643.8469 NM</p> <p>----- 587.5600 NM</p> <p>----- 546.0700 NM</p> <p>----- 486.1300 NM</p> <p>----- 460.0000 NM</p>
------------------------------------------------------------------------------	------------------------------------------------------------------------------------------------------------------------------



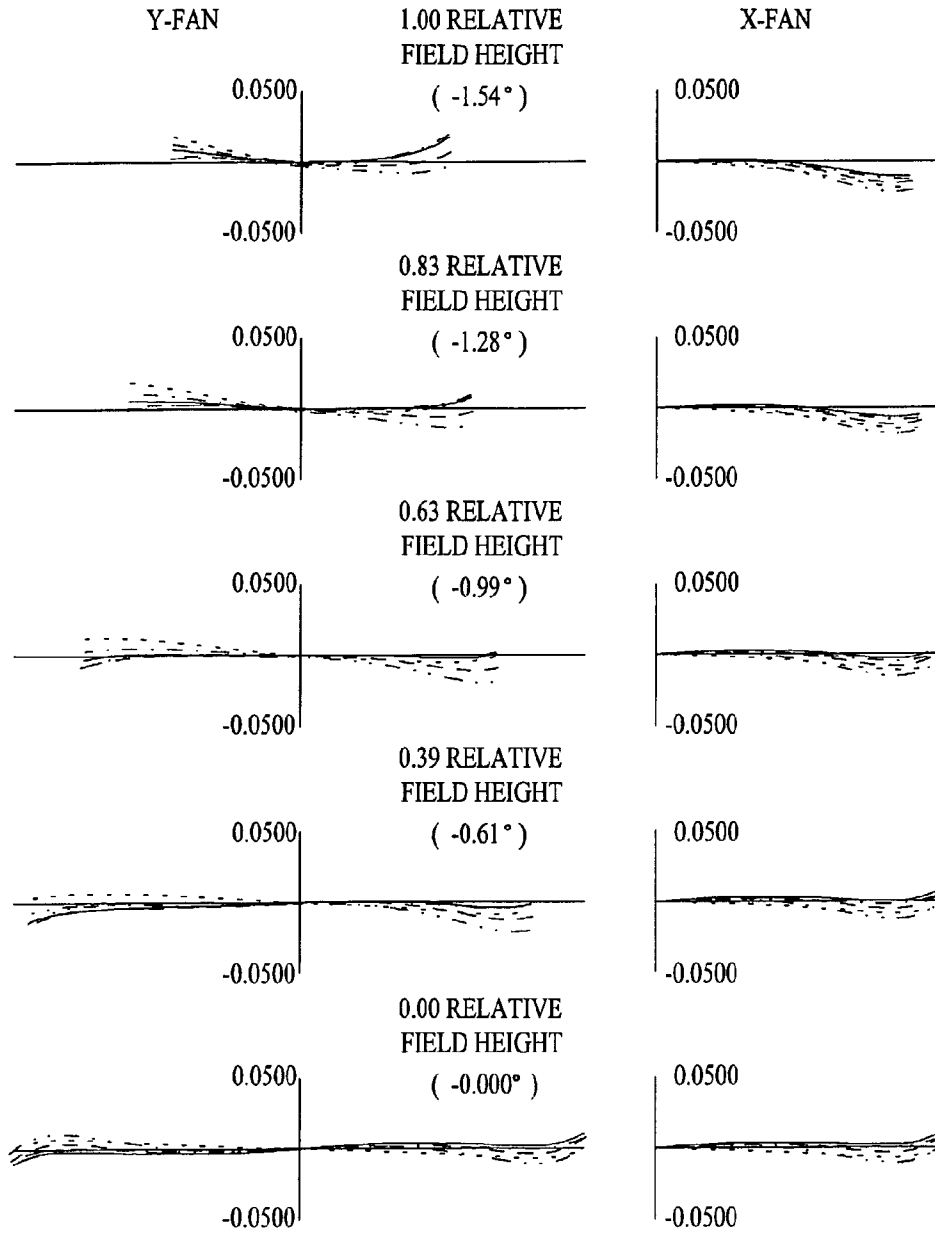
<p><i>Fig. 44</i></p> <p>RAY ABERRATIONS (MILLIMETERS)</p> <p>POSITION 6</p>	<p>----- 643.8469 NM</p> <p>----- 587.5600 NM</p> <p>----- 546.0700 NM</p> <p>----- 486.1300 NM</p> <p>----- 460.0000 NM</p>
------------------------------------------------------------------------------	------------------------------------------------------------------------------------------------------------------------------



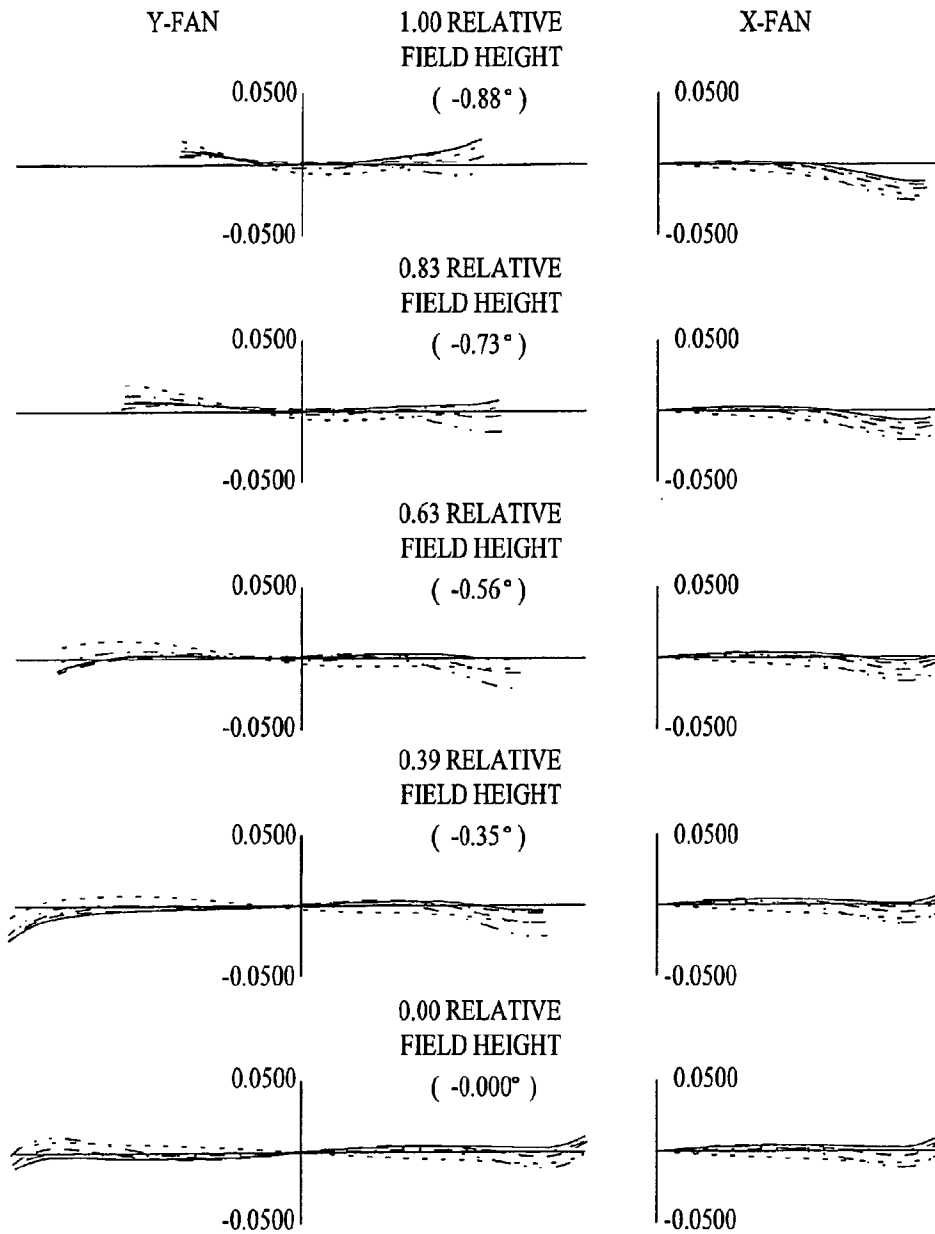
<p><i>Fig. 45</i></p> <p>RAY ABERRATIONS (MILLIMETERS)</p> <p>POSITION 7</p>	<p>----- 643.8469 NM</p> <p>----- 587.5600 NM</p> <p>----- 546.0700 NM</p> <p>----- 486.1300 NM</p> <p>----- 460.0000 NM</p>
------------------------------------------------------------------------------	------------------------------------------------------------------------------------------------------------------------------



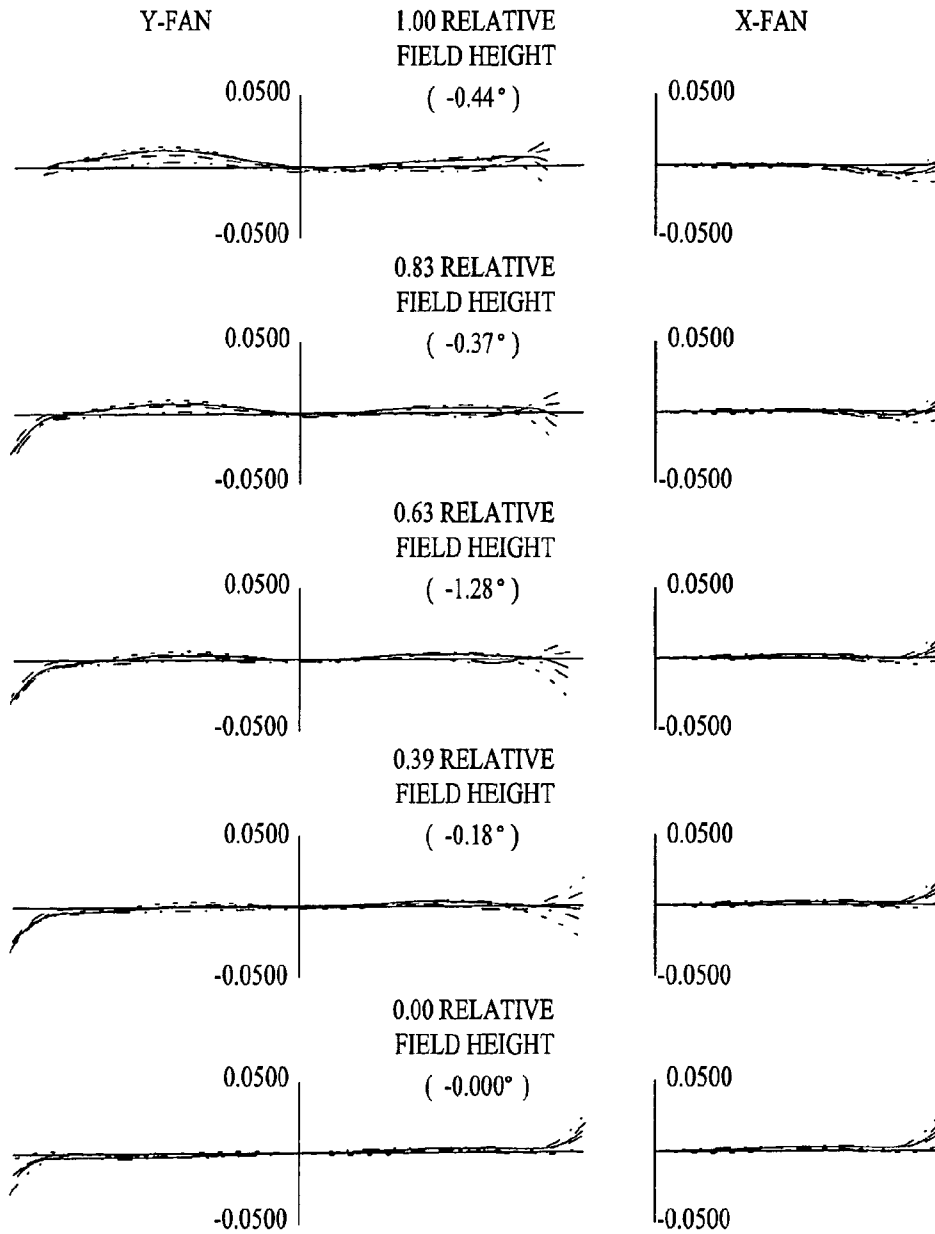
<p><i>Fig. 40</i></p> <p>RAY ABERRATIONS (MILLIMETERS)</p> <p>POSITION 8</p>	<p>----- 643.8469 NM</p> <p>----- 587.5600 NM</p> <p>----- 546.0700 NM</p> <p>----- 486.1300 NM</p> <p>----- 460.0000 NM</p>
------------------------------------------------------------------------------	------------------------------------------------------------------------------------------------------------------------------



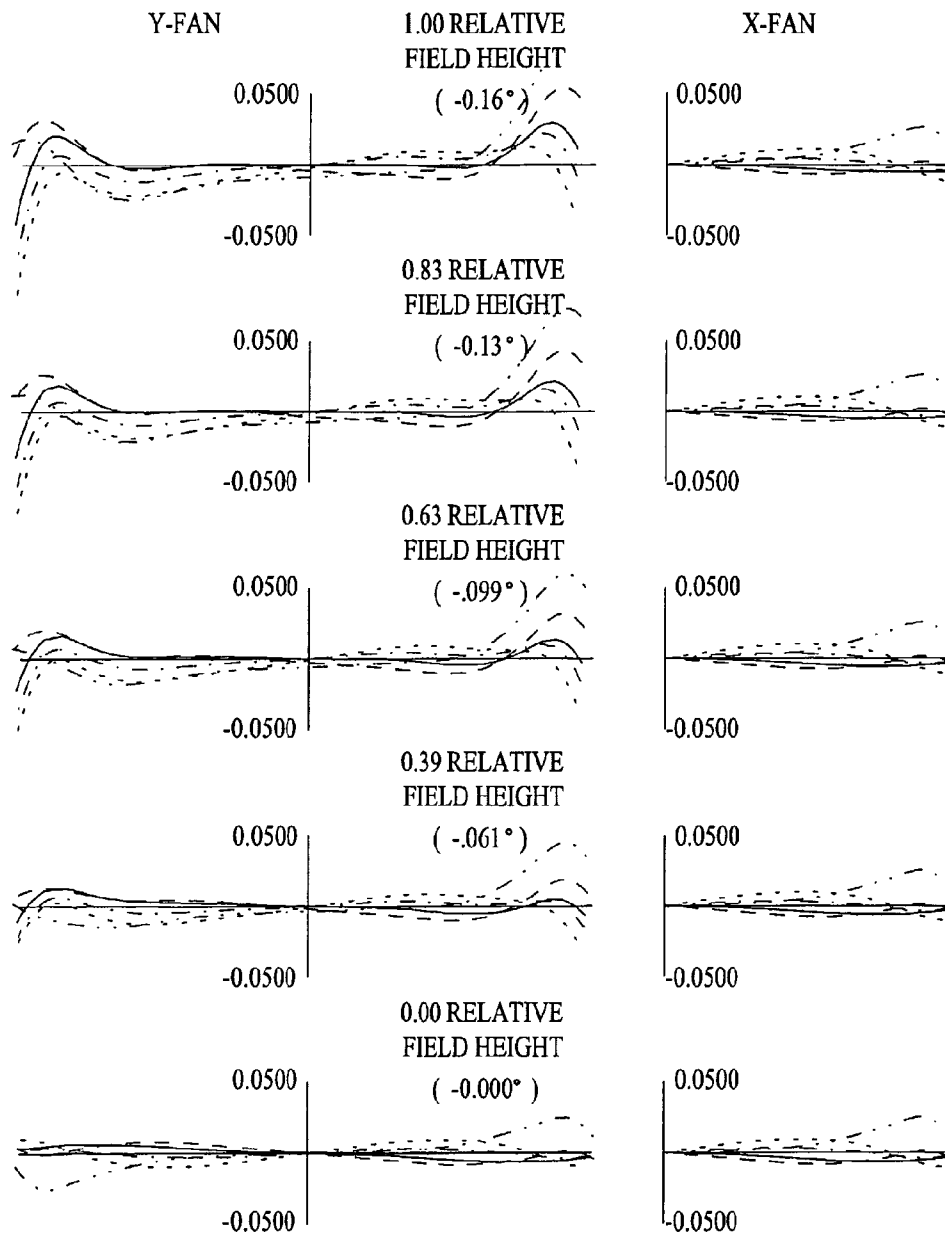
<p><i>FIG. 47</i></p> <p>RAY ABERRATIONS (MILLIMETERS)</p> <p>POSITION 9</p>	<p>----- 643.8469 NM</p> <p>----- 587.5600 NM</p> <p>----- 546.0700 NM</p> <p>----- 486.1300 NM</p> <p>----- 460.0000 NM</p>
------------------------------------------------------------------------------	------------------------------------------------------------------------------------------------------------------------------



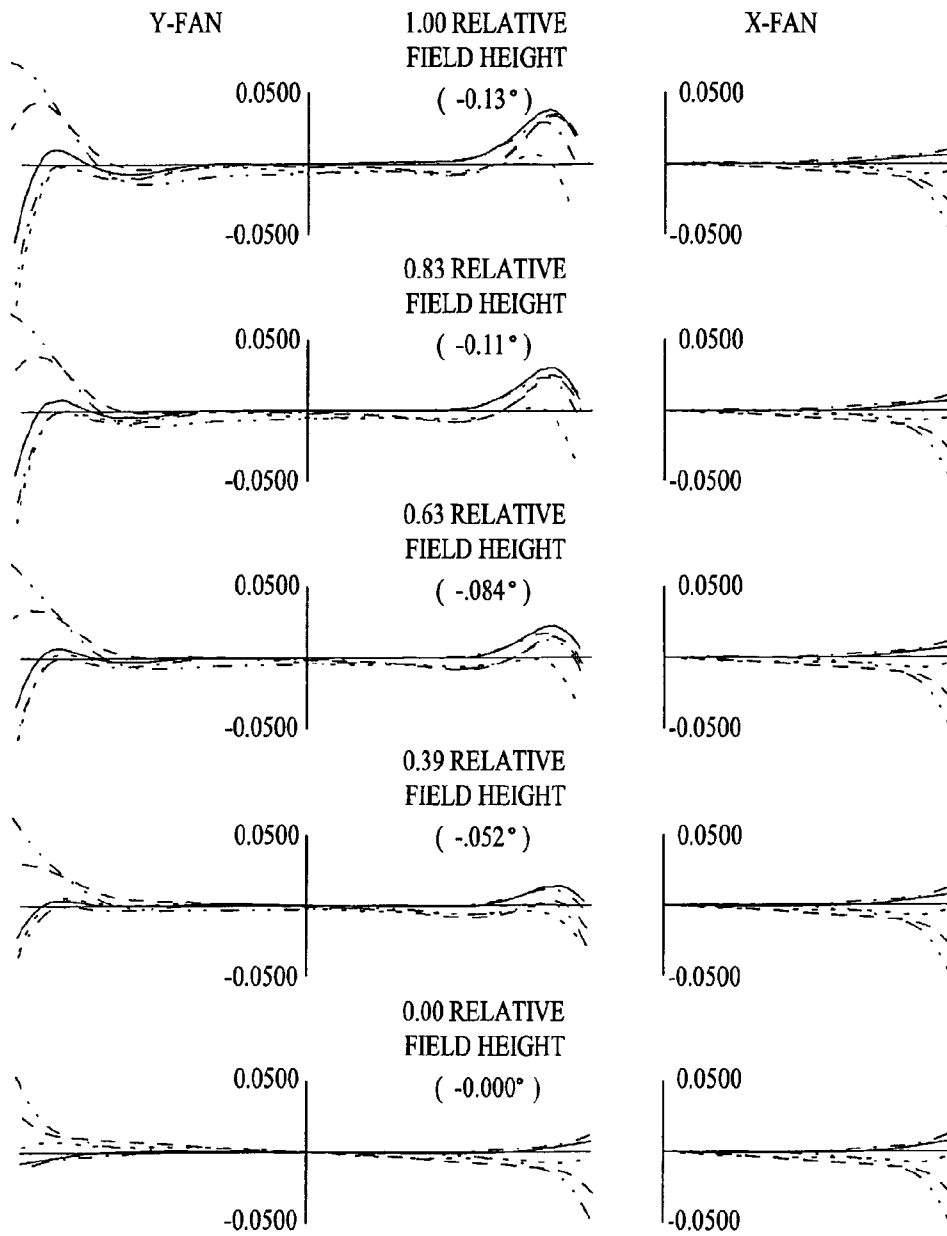
<p><i>Fig. 4B</i></p> <p>RAY ABERRATIONS (MILLIMETERS)</p> <p>POSITION 10</p>	<p>..... 643.8469 NM</p> <p>----- 587.5600 NM</p> <p>———— 546.0700 NM</p> <p>- - - - 486.1300 NM</p> <p>- . - . 460.0000 NM</p>
-------------------------------------------------------------------------------	---------------------------------------------------------------------------------------------------------------------------------



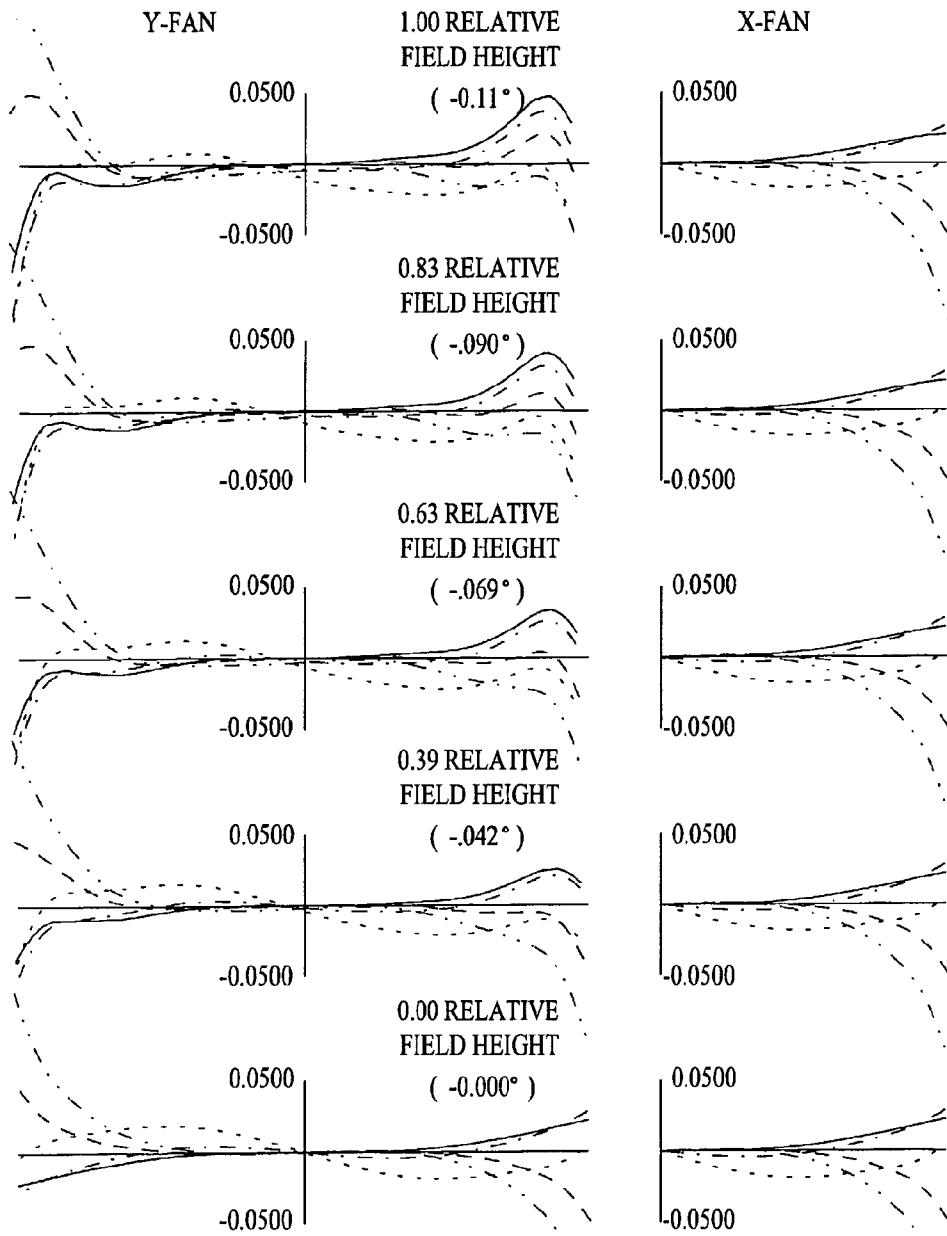
<p><i>Fig. 49</i></p> <p>RAY ABERRATIONS (MILLIMETERS)</p> <p>POSITION 11</p>	<p>----- 643.8469 NM</p> <p>----- 587.5600 NM</p> <p>----- 546.0700 NM</p> <p>----- 486.1300 NM</p> <p>----- 460.0000 NM</p>
-------------------------------------------------------------------------------	------------------------------------------------------------------------------------------------------------------------------



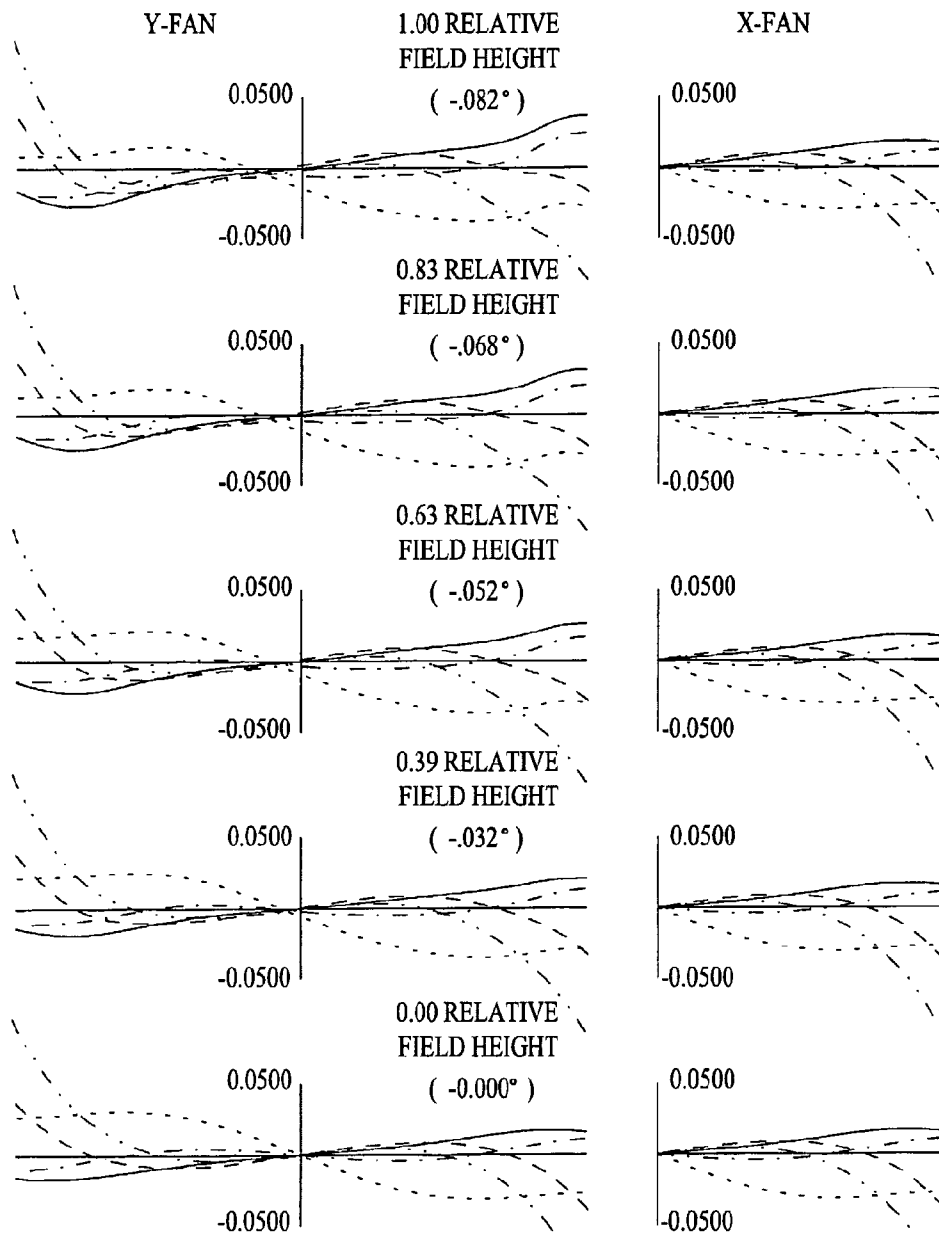
<p><i>Fig. 50</i></p> <p>RAY ABERRATIONS (MILLIMETERS)</p> <p>POSITION 12</p>	<p>----- 643.8469 NM</p> <p>----- 587.5600 NM</p> <p>----- 546.0700 NM</p> <p>----- 486.1300 NM</p> <p>----- 460.0000 NM</p>
-------------------------------------------------------------------------------	------------------------------------------------------------------------------------------------------------------------------



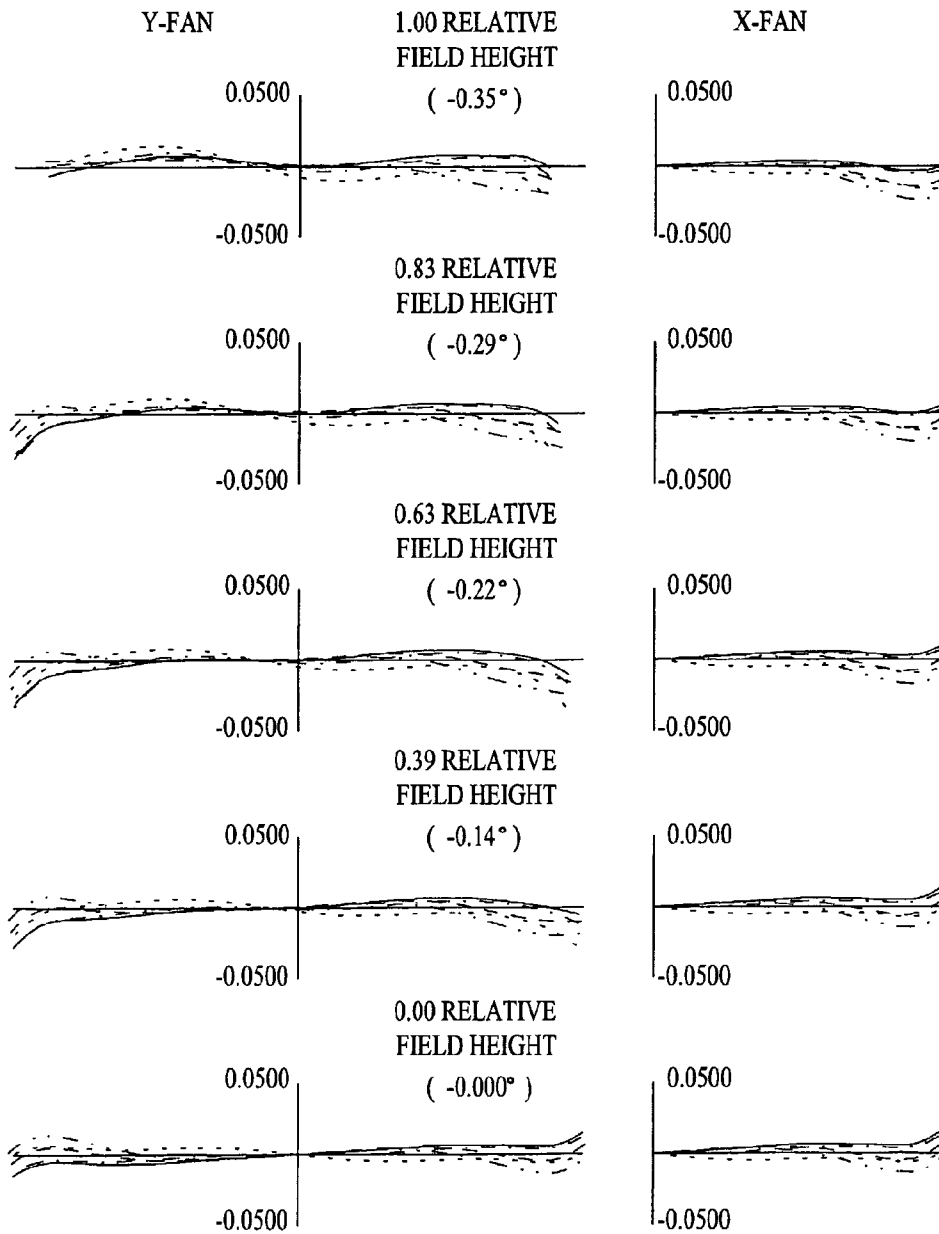
<p><i>Fig. 51</i></p> <p>RAY ABERRATIONS (MILLIMETERS)</p> <p>POSITION 13</p>	<p>----- 643.8469 NM</p> <p>----- 587.5600 NM</p> <p>----- 546.0700 NM</p> <p>----- 486.1300 NM</p> <p>----- 460.0000 NM</p>
-------------------------------------------------------------------------------	------------------------------------------------------------------------------------------------------------------------------



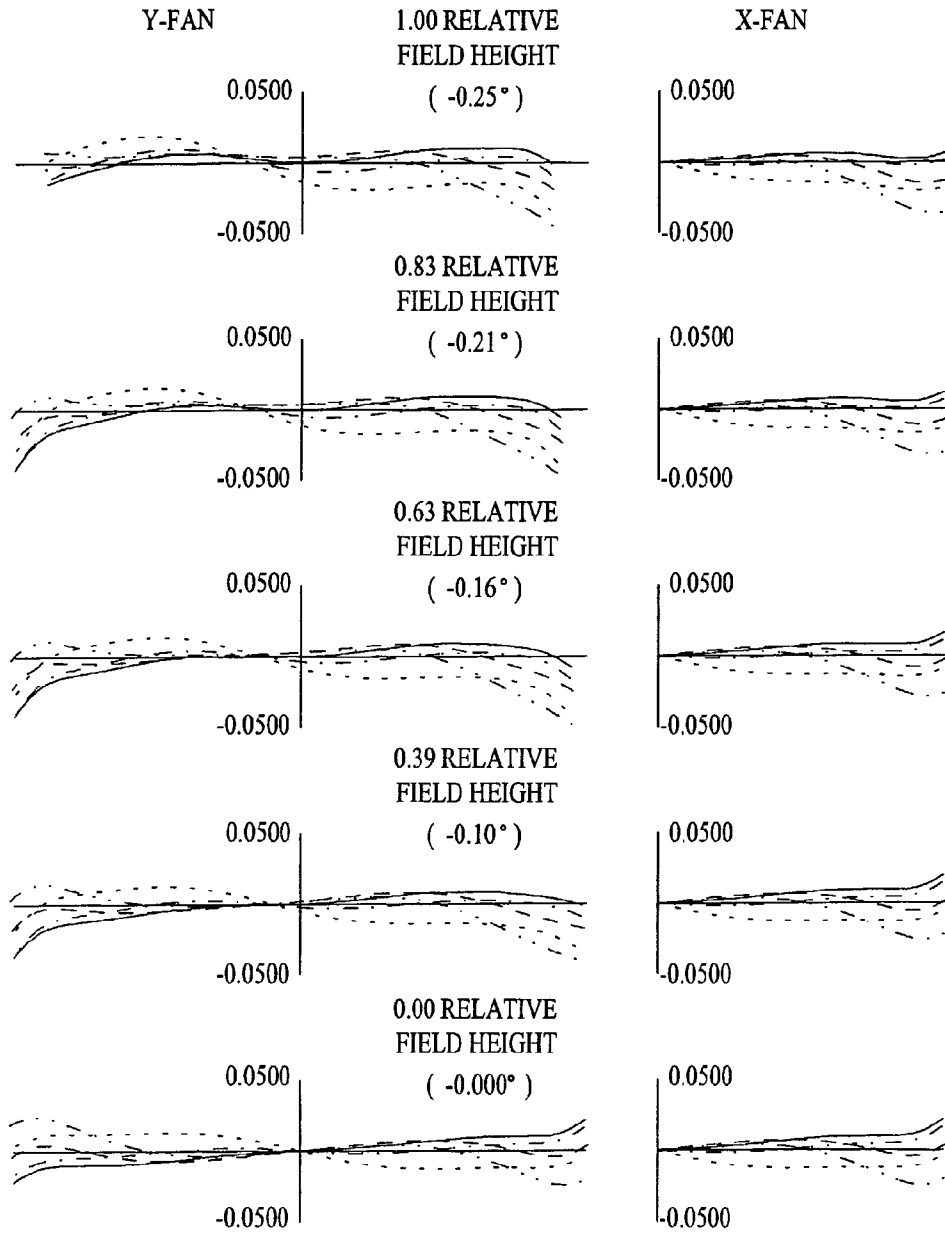
<p><b>Fig. 52</b> RAY ABERRATIONS (MILLIMETERS) POSITION 14</p>	<p>..... 643.8469 NM - - - - 587.5600 NM _____ 546.0700 NM - - - - 486.1300 NM - . - . 460.0000 NM</p>
-------------------------------------------------------------------------	------------------------------------------------------------------------------------------------------------------------



<p><b>FIG. 53</b> RAY ABERRATIONS (MILLIMETERS) POSITION 15</p>	<p>----- 643.8469 NM                  ----- 587.5600 NM                  ----- 546.0700 NM                  ----- 486.1300 NM                  ----- 460.0000 NM</p>
-------------------------------------------------------------------------	--------------------------------------------------------------------------------------------------------------------------------------------------------------------------------------

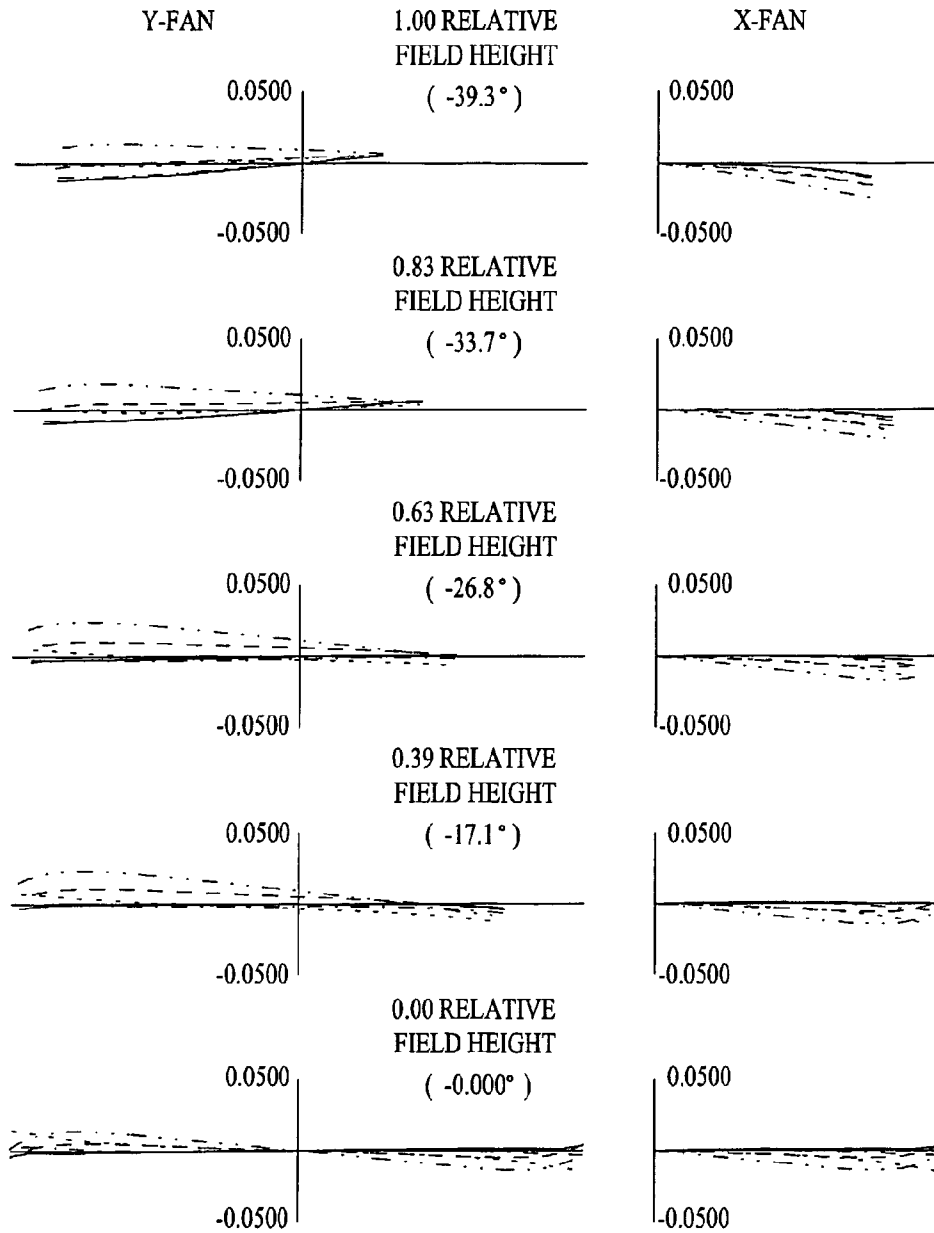


<p><i>Fig. 54</i></p> <p>RAY ABERRATIONS (MILLIMETERS)</p> <p>POSITION 16</p>	<p>----- 643.8469 NM</p> <p>----- 587.5600 NM</p> <p>----- 546.0700 NM</p> <p>----- 486.1300 NM</p> <p>----- 460.0000 NM</p>
-------------------------------------------------------------------------------	------------------------------------------------------------------------------------------------------------------------------

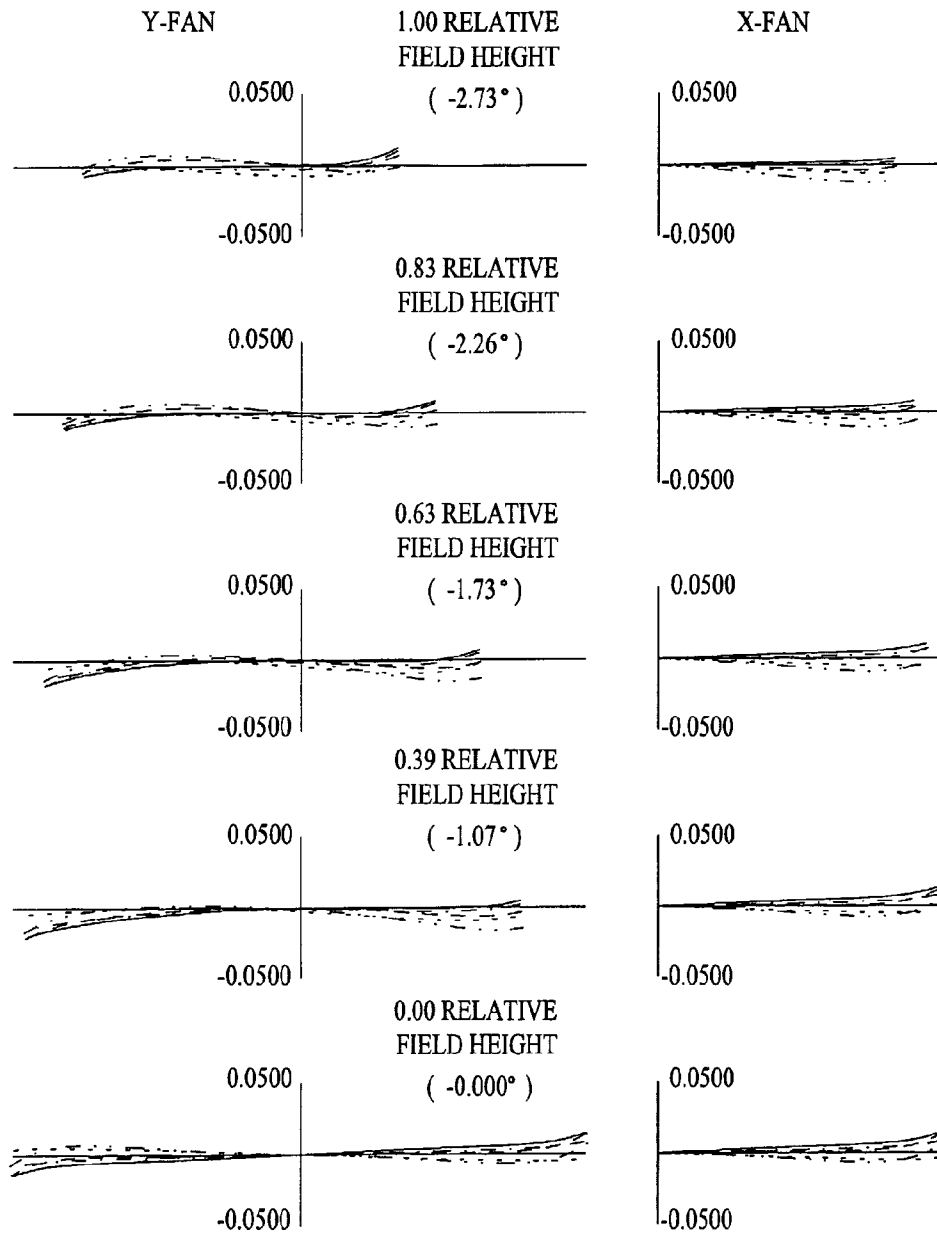


<p><b>Fig. 55</b> RAY ABERRATIONS (MILLIMETERS) POSITION 17</p>	<p>----- -643.8469 NM</p> <p>----- -587.5600 NM</p> <p>----- -546.0700 NM</p> <p>----- -486.1300 NM</p> <p>----- -460.0000 NM</p>
-------------------------------------------------------------------------	-----------------------------------------------------------------------------------------------------------------------------------

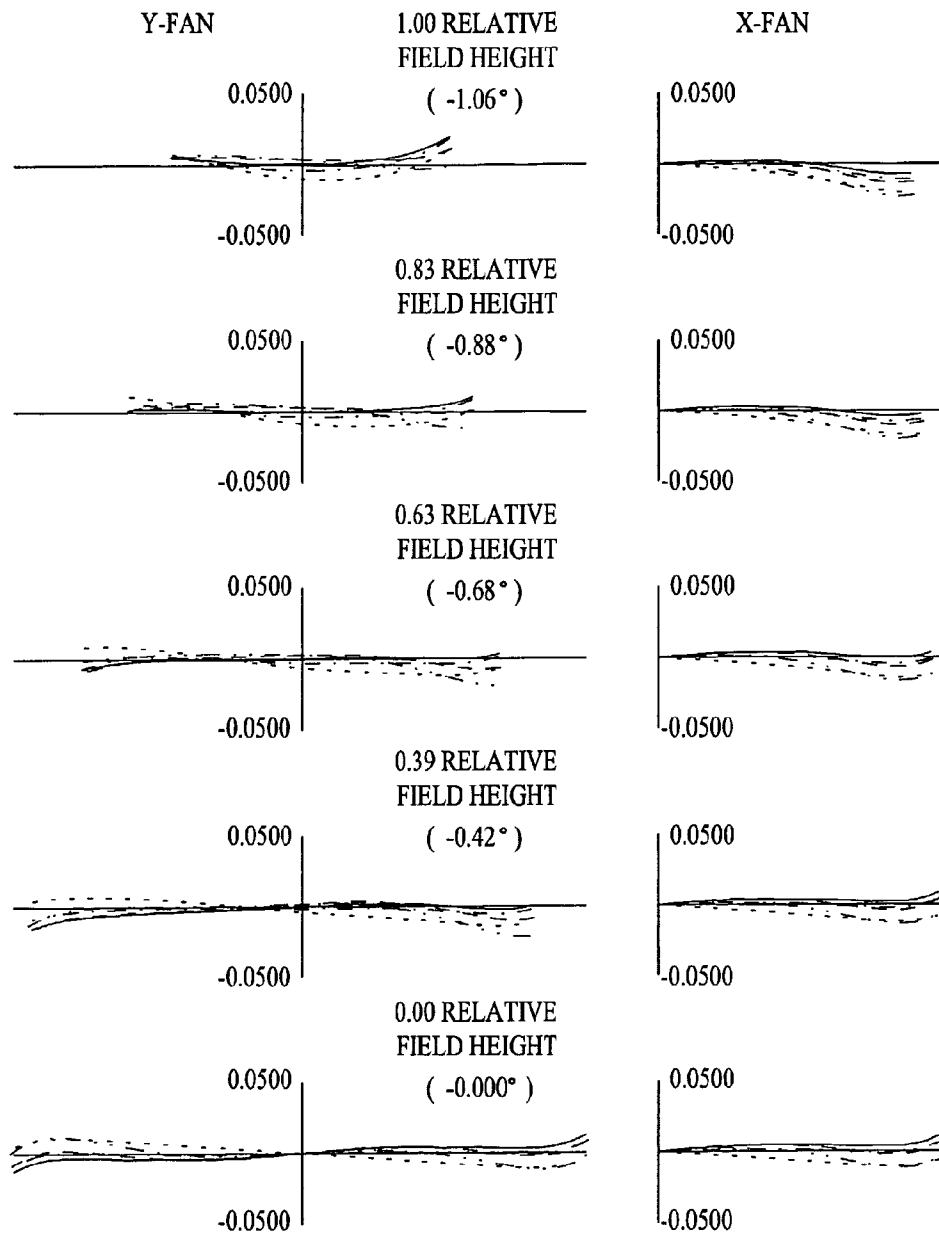
56/76



<p><i>Fig. 50</i></p> <p>RAY ABERRATIONS (MILLIMETERS)</p> <p>POSITION 18</p>	<p>----- 643.8469 NM</p> <p>----- 587.5600 NM</p> <p>----- 546.0700 NM</p> <p>----- 486.1300 NM</p> <p>----- 460.0000 NM</p>
-------------------------------------------------------------------------------	------------------------------------------------------------------------------------------------------------------------------

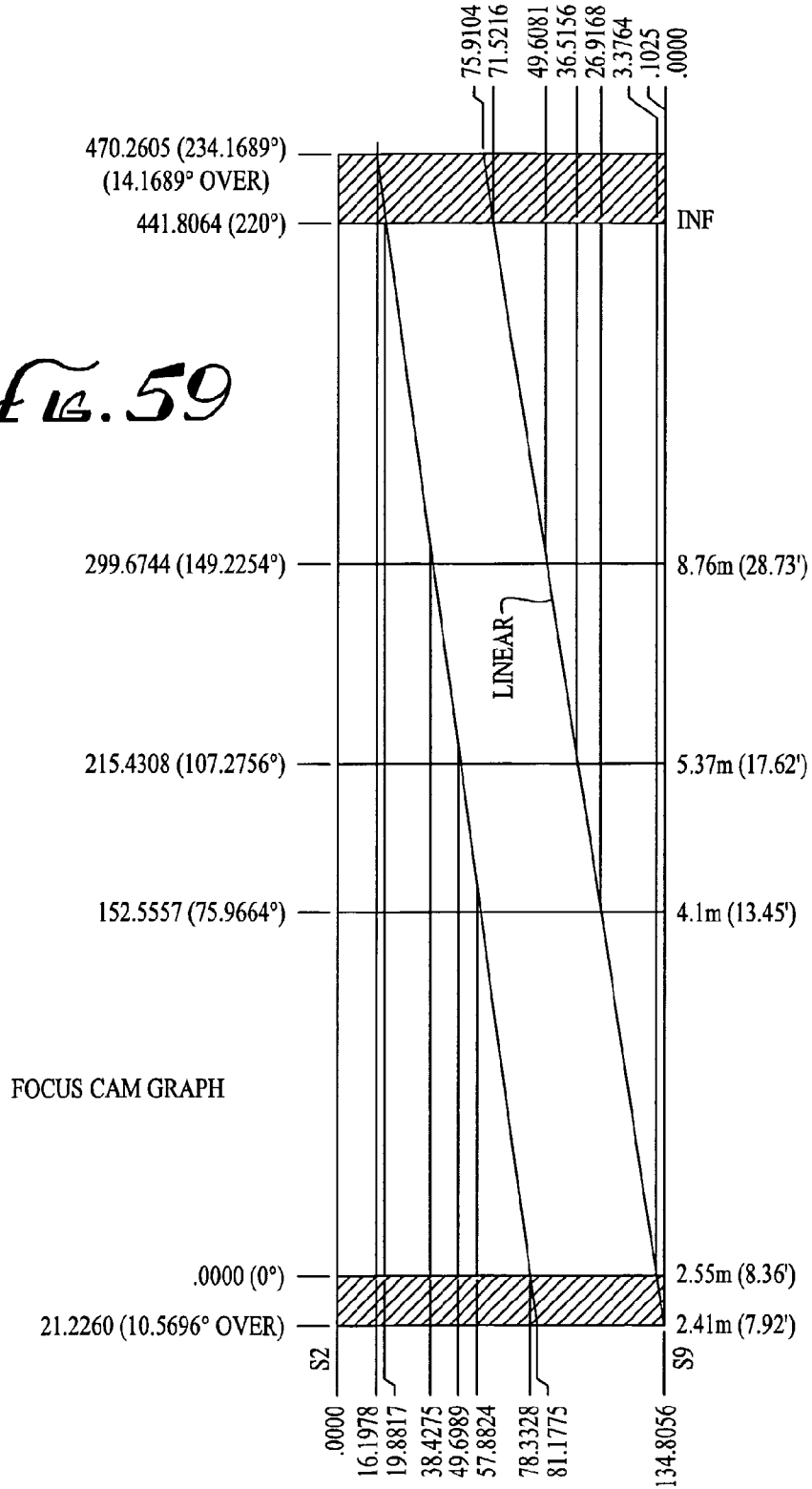


<p><b>Fig. 57</b></p> <p>RAY ABERRATIONS (MILLIMETERS)</p> <p>POSITION 19</p>	<p>----- 643.8469 NM</p> <p>----- 587.5600 NM</p> <p>----- 546.0700 NM</p> <p>----- 486.1300 NM</p> <p>----- 460.0000 NM</p>
-------------------------------------------------------------------------------	------------------------------------------------------------------------------------------------------------------------------



<p><i>Fig. 58</i></p> <p>RAY ABERRATIONS (MILLIMETERS)</p> <p>POSITION 20</p>	<p>----- 643.8469 NM</p> <p>----- 587.5600 NM</p> <p>----- 546.0700 NM</p> <p>----- 486.1300 NM</p> <p>----- 460.0000 NM</p>
-------------------------------------------------------------------------------	------------------------------------------------------------------------------------------------------------------------------

*Fig. 59*



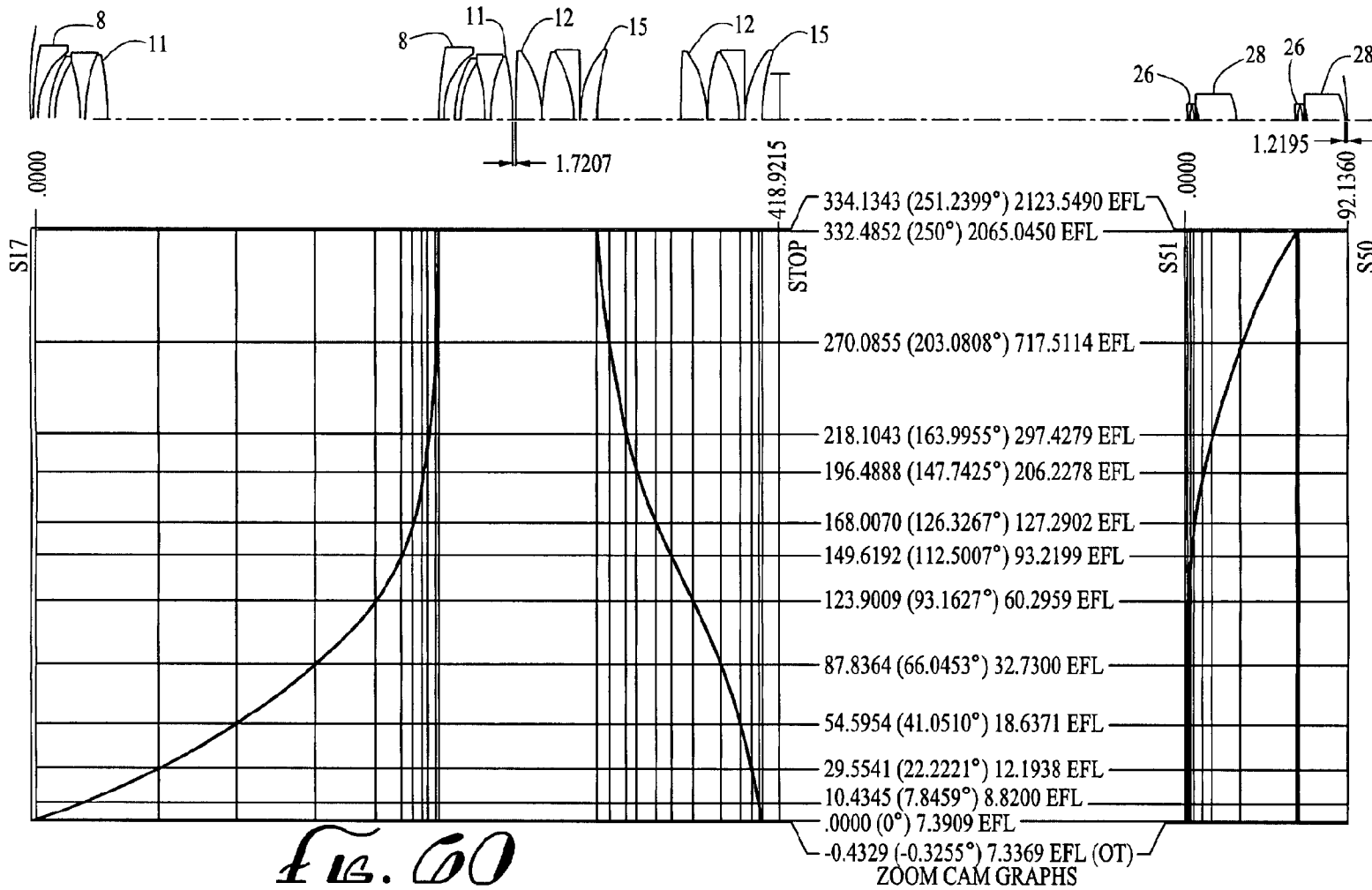
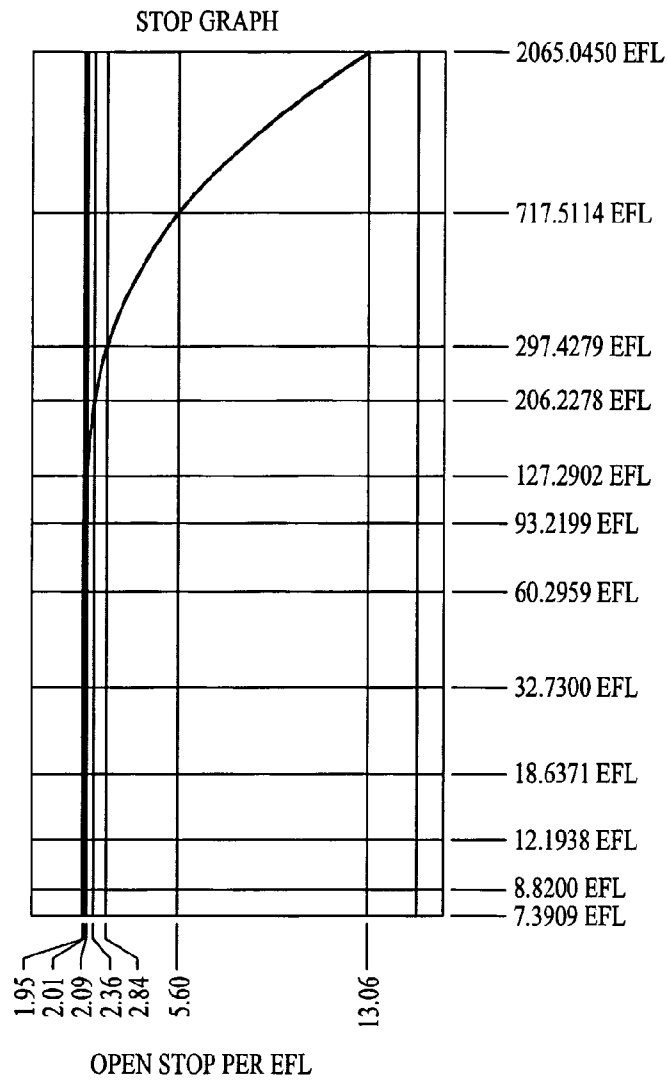
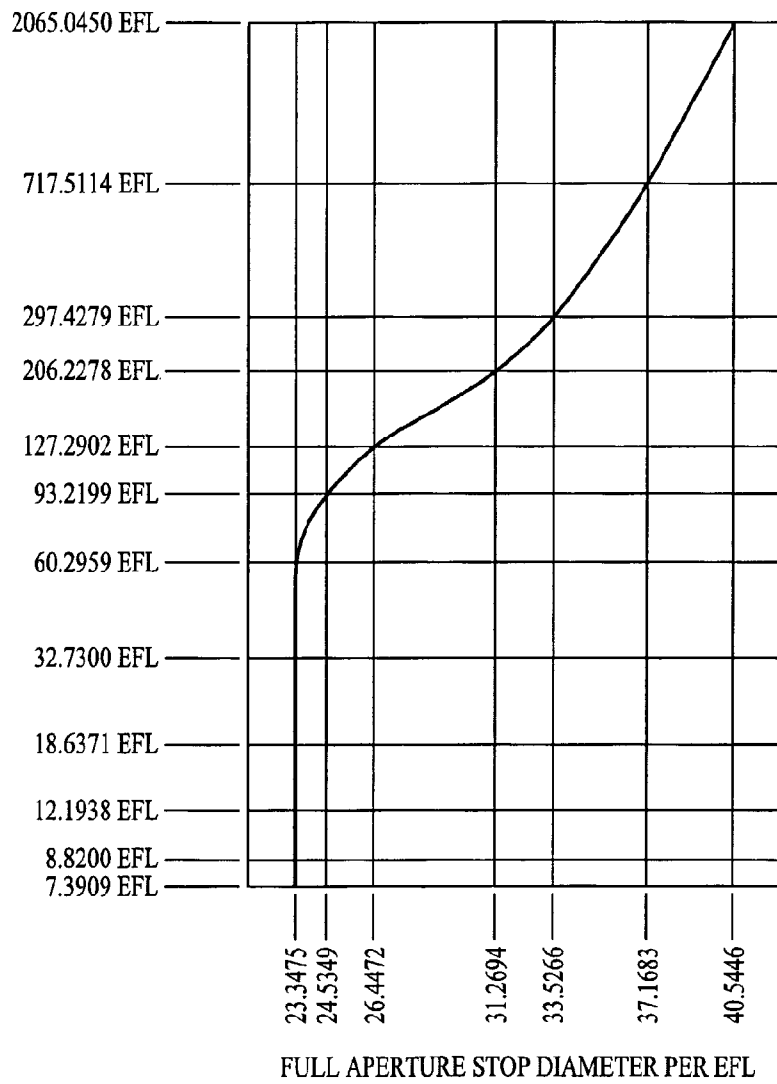


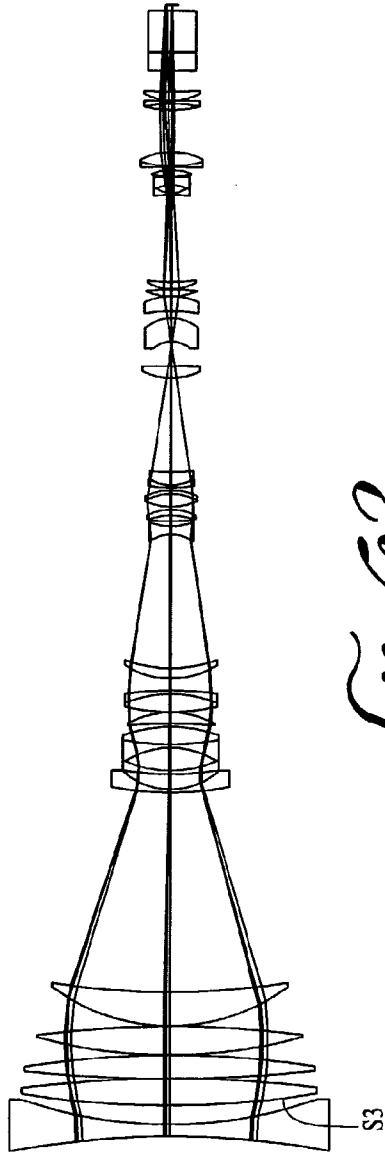
FIG. 60



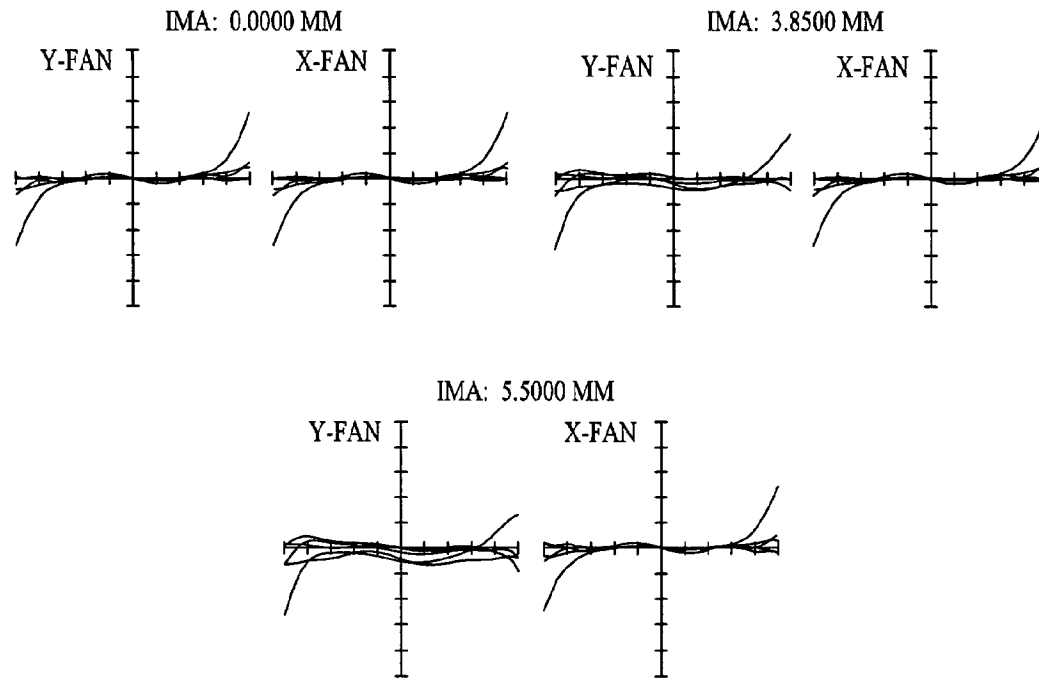
*FIG. 01*



*FIG. 02*



*FIG. 03*



*FIG. 04*

WAVE LENGTHS RANGE 455-656 NM  
 MAXIMUM VERTICAL SCALE +/- 100 MICRONS

FOCUS DISTANCE = INFINITY

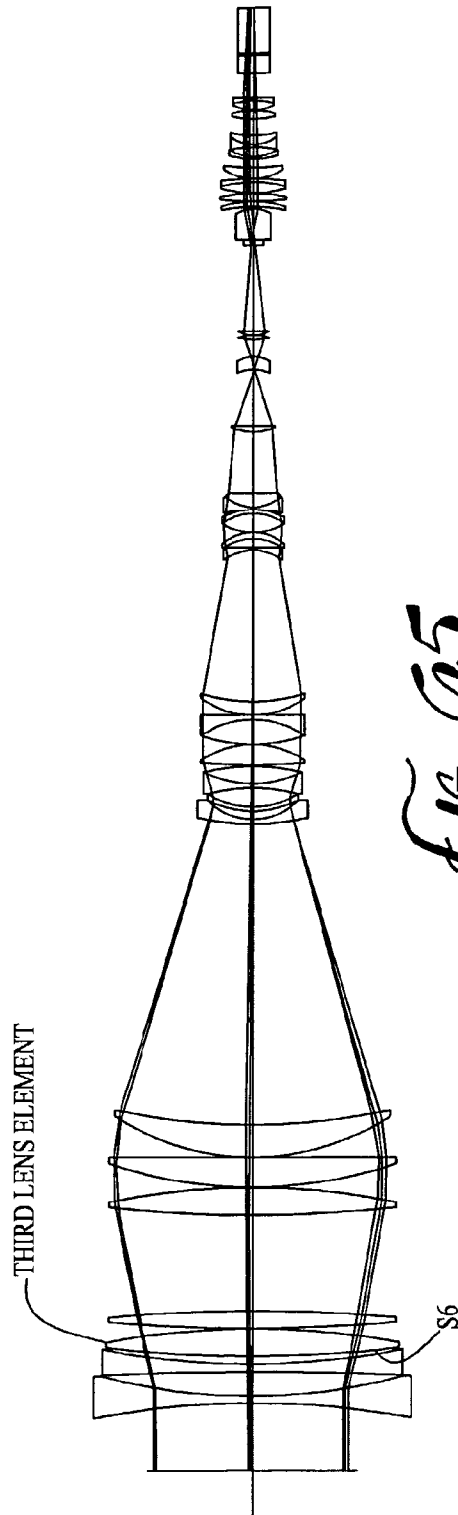
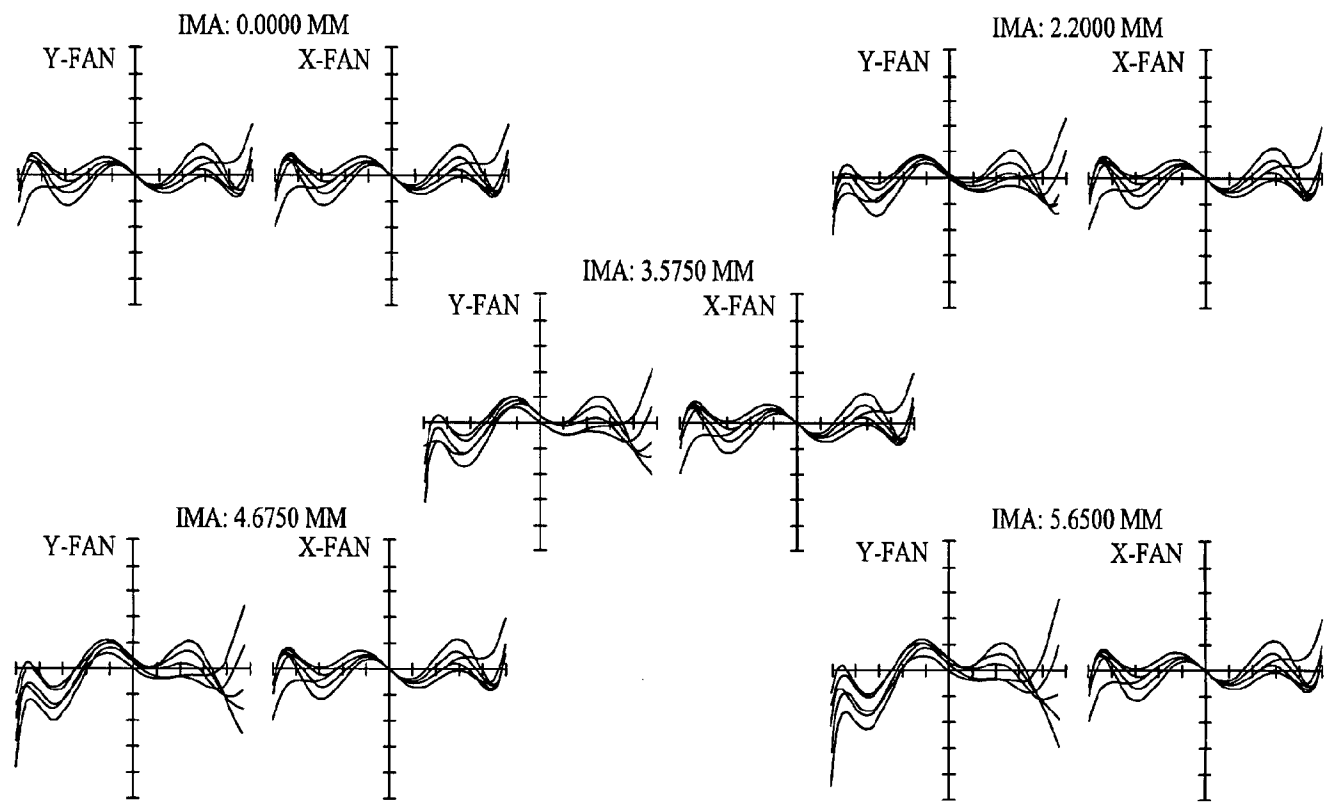


FIG. 05



*Fig. 60*

WAVE LENGTHS RANGE 460-644 NM  
 MAXIMUM VERTICAL SCALE +/- 100 MICRONS

EFL = 7.47MM

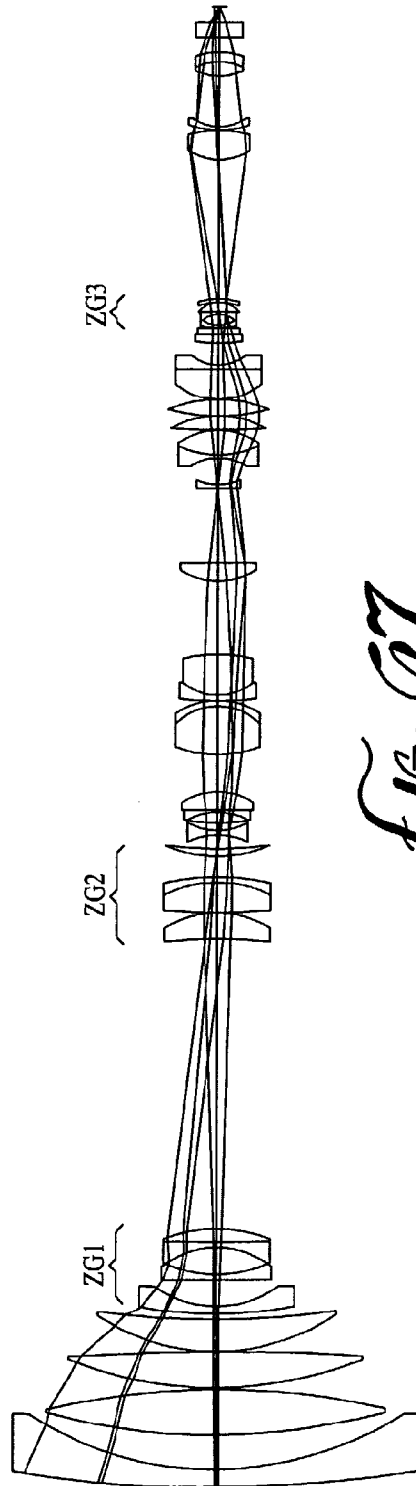
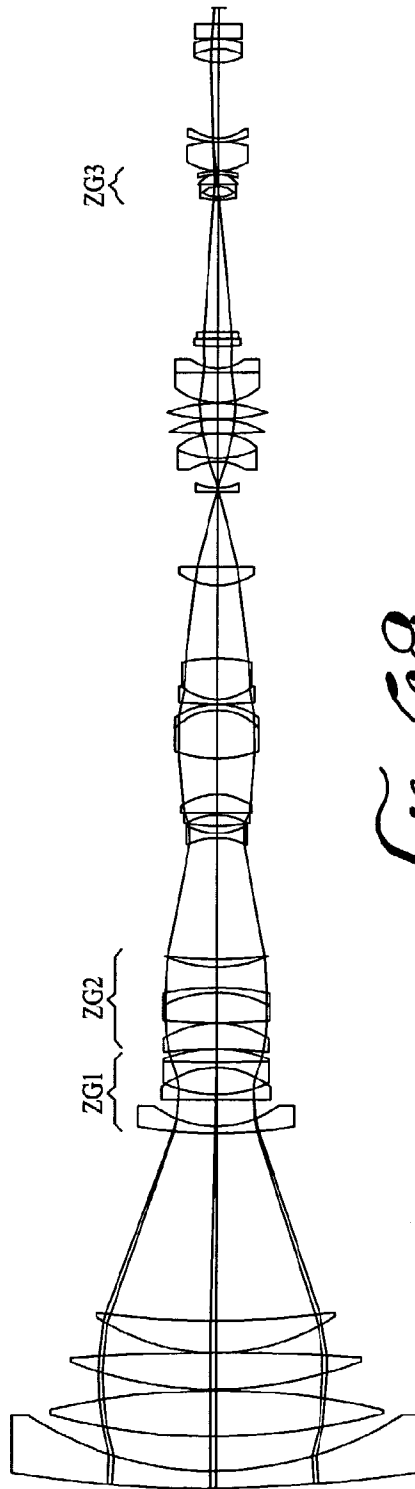
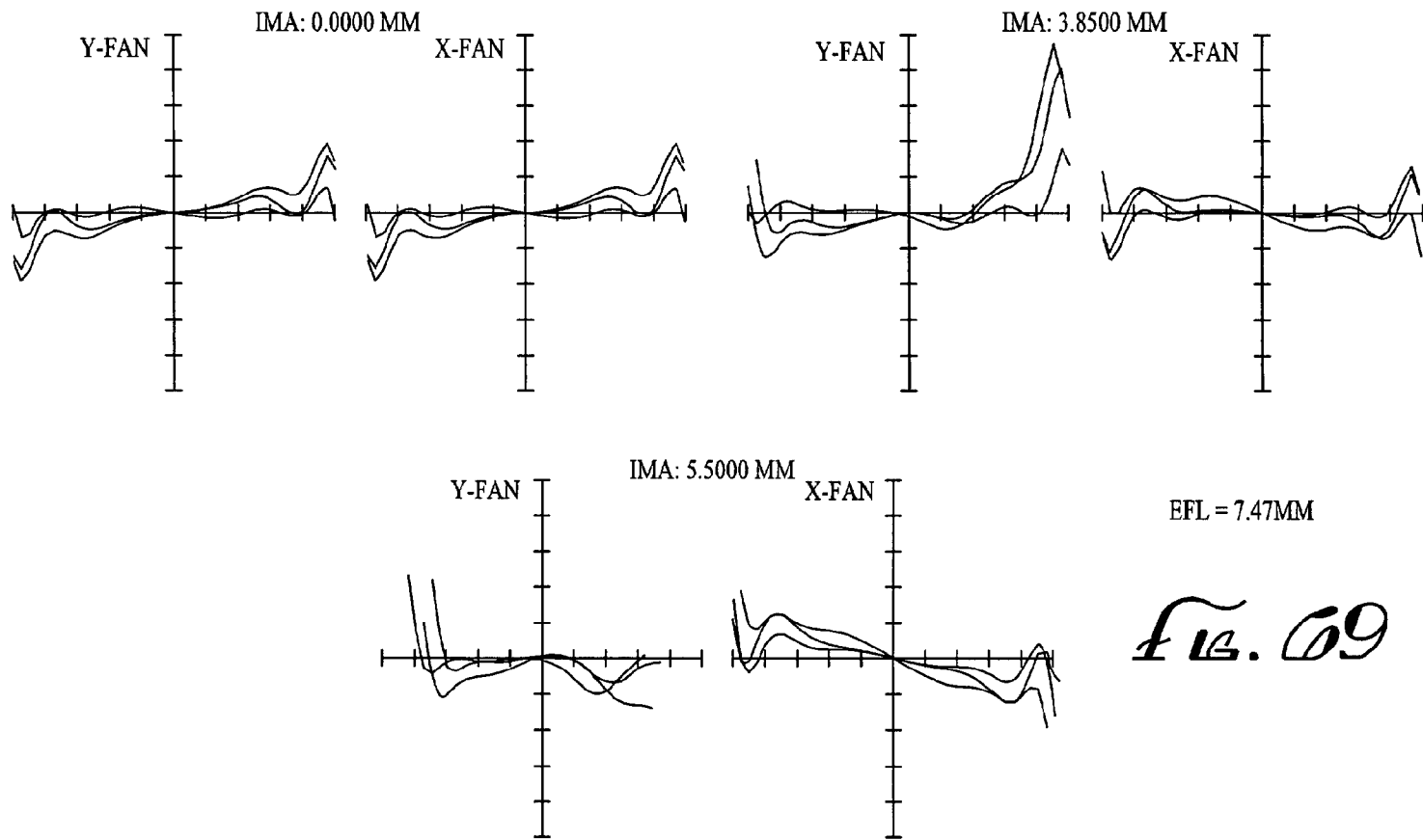


FIG. 07

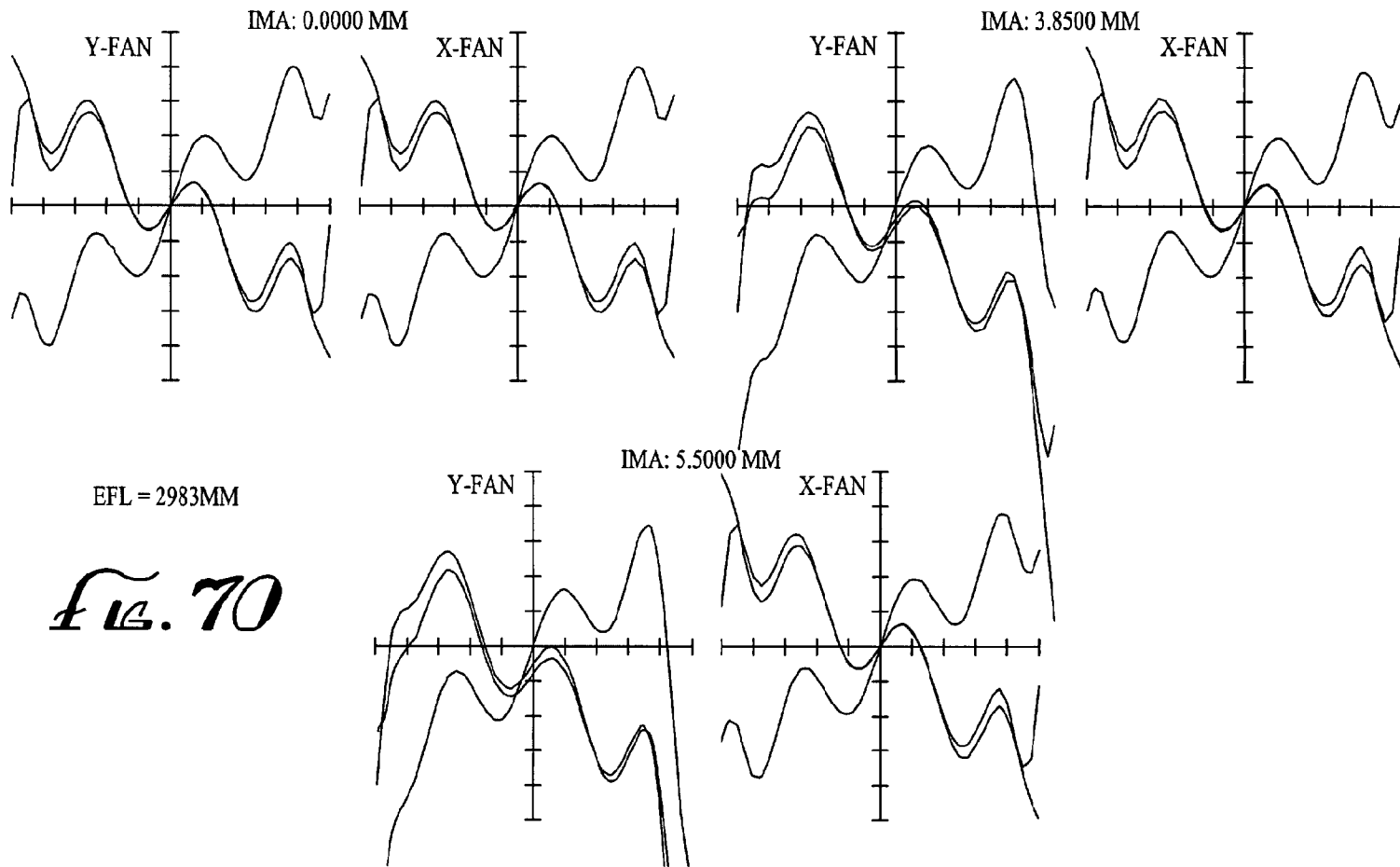
EFL = 2983MM





*Fig. 09*

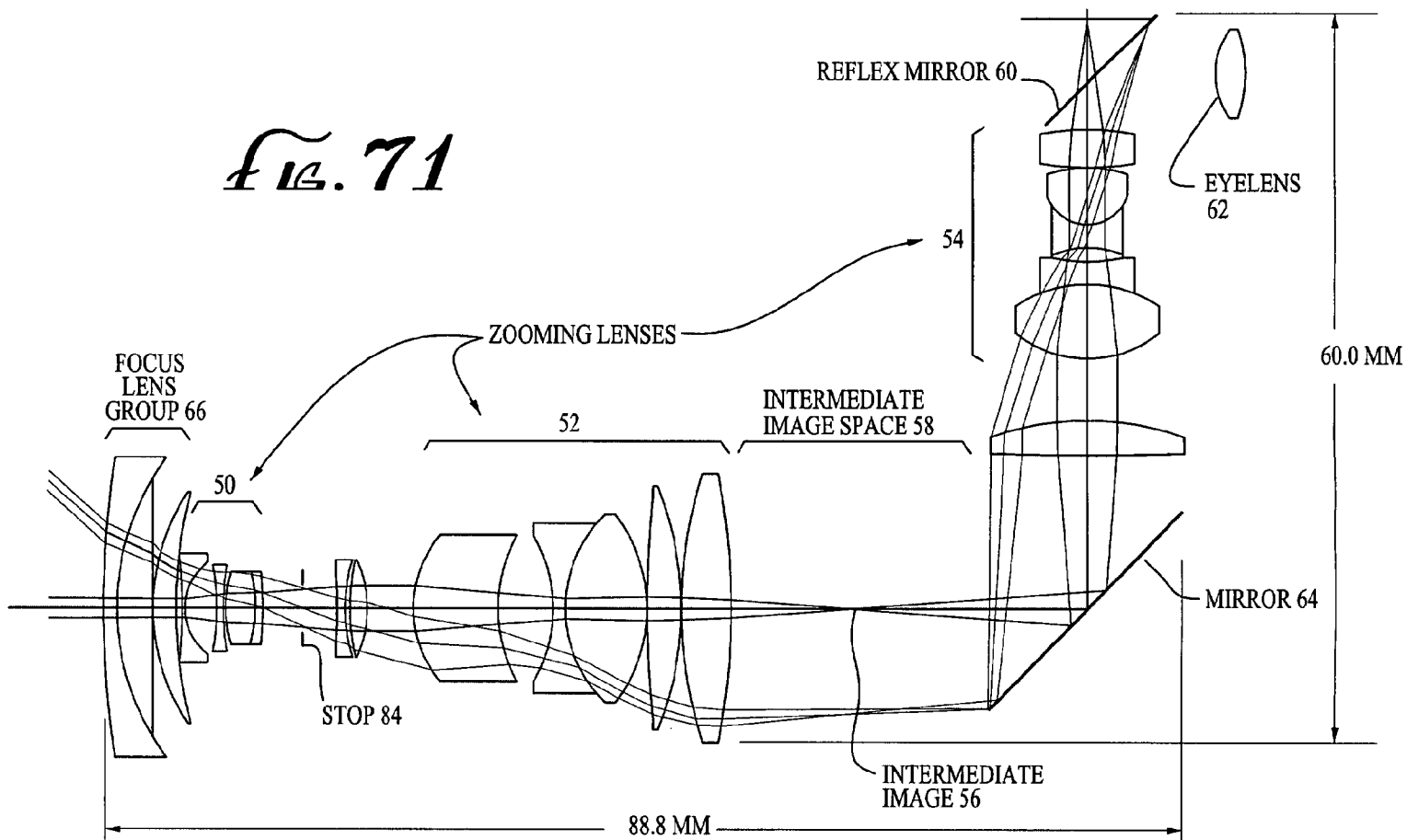
WAVE LENGTHS RANGE 480-644 NM  
 MAXIMUM VERTICAL SCALE +/- 100 MICRONS



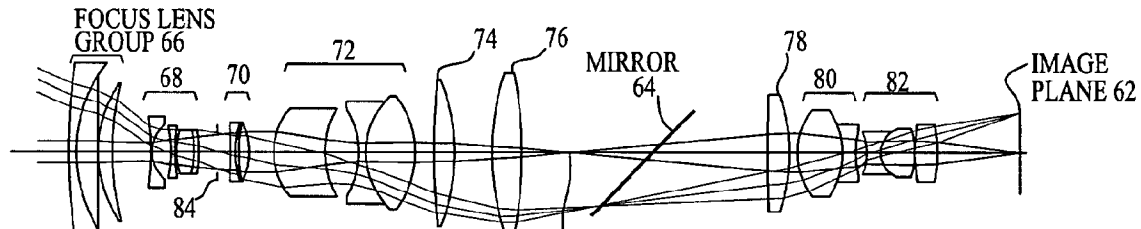
**Fig. 70**

WAVE LENGTHS RANGE 480-644 NM  
 MAXIMUM VERTICAL SCALE +/- 100 MICRONS

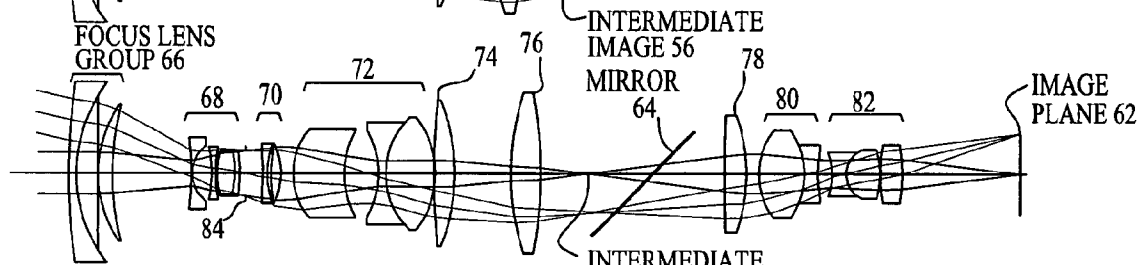
FIG. 71



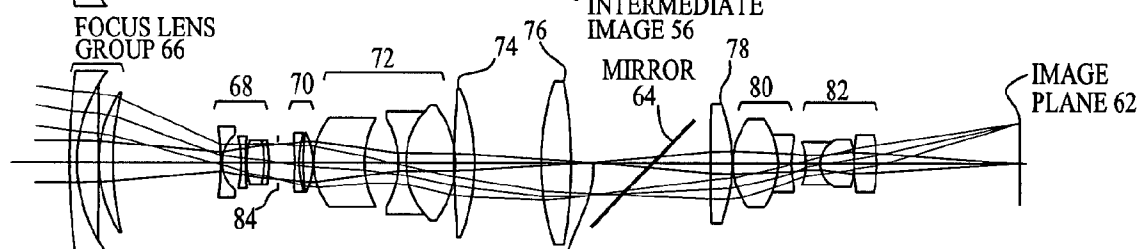
71/76



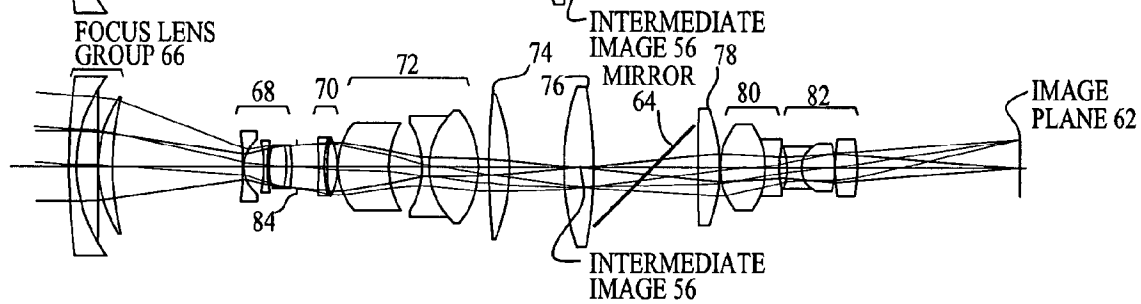
*FIG. 72A*



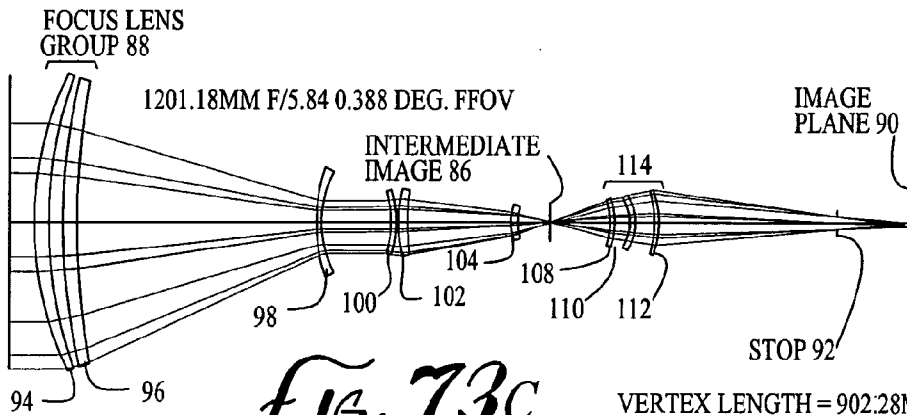
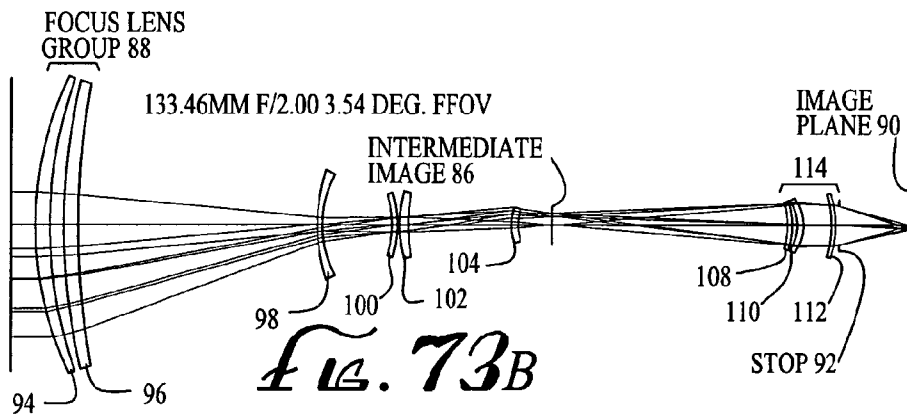
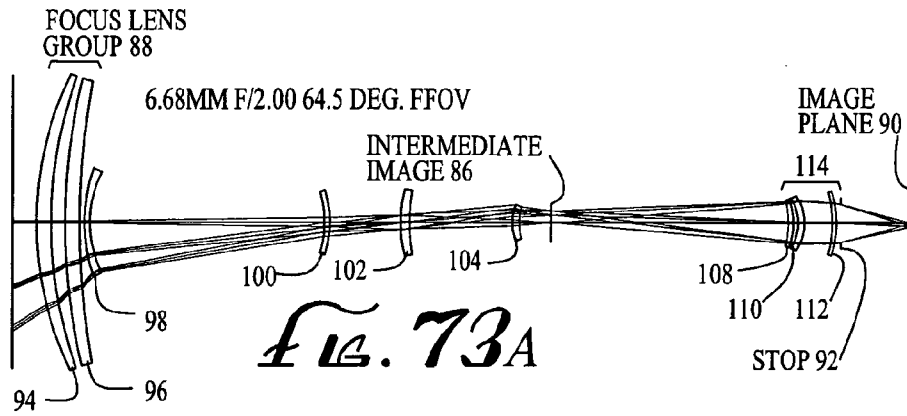
*FIG. 72B*

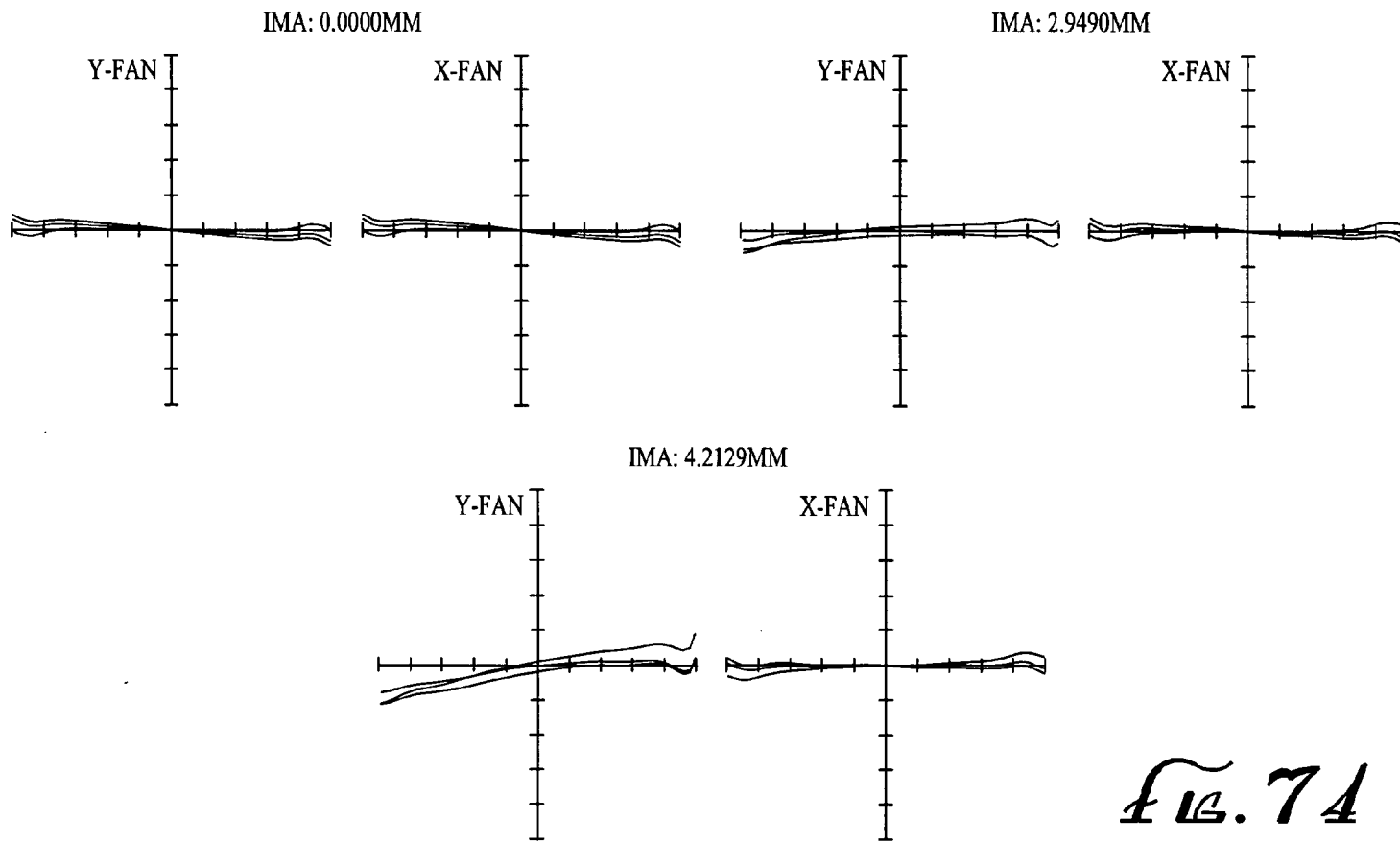


*FIG. 72C*



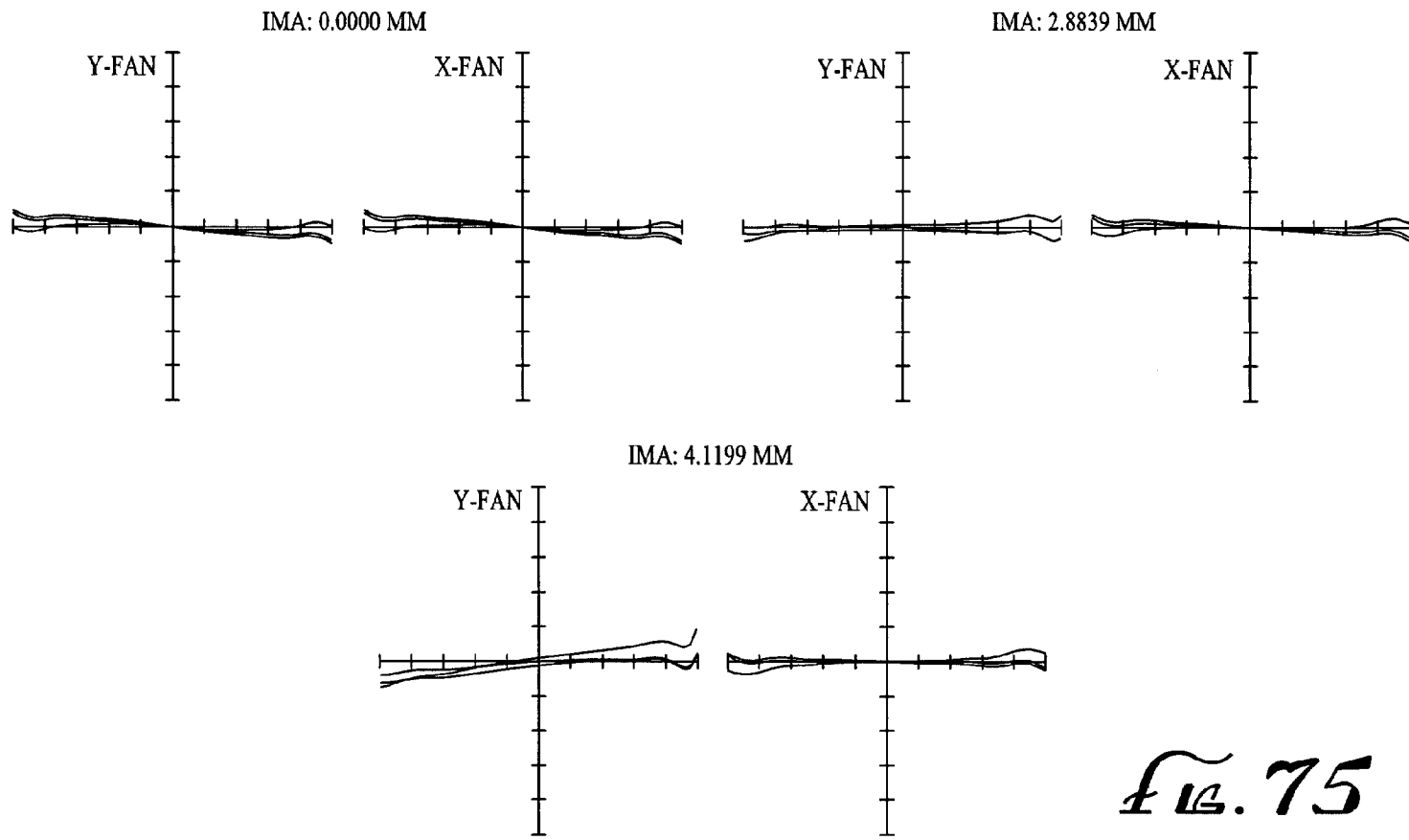
*FIG. 72D*





WAVELENGTH RANGE 8-12 MICRONS  
 MAXIMUM VERTICAL SCALE +/- 200 MICRONS

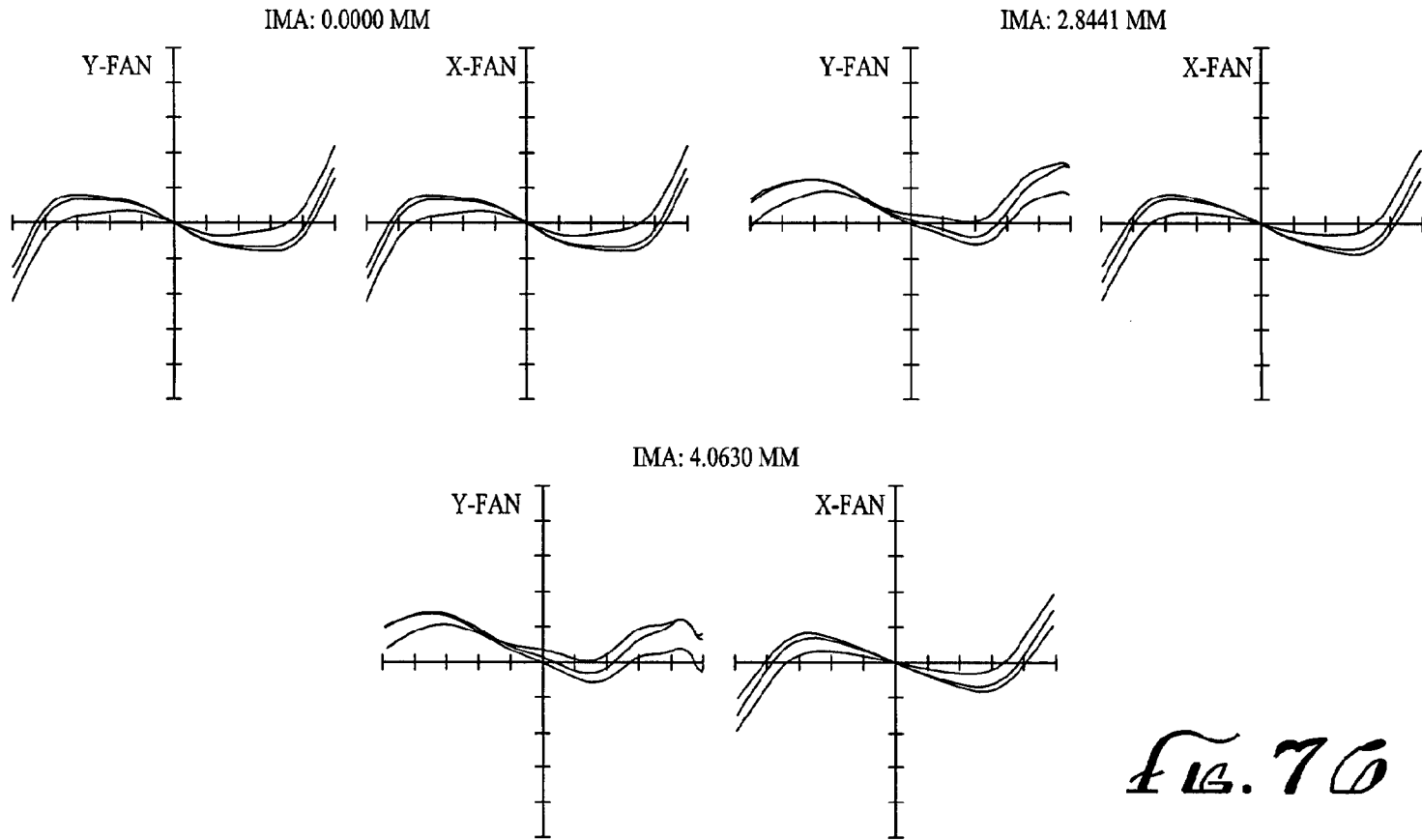
*Fig. 74*



WAVELENGTH RANGE 8-12 MICRONS  
 MAXIMUM VERTICAL SCALE +/- 200 MICRONS

*Fig. 75*

75/76



WAVELENGTH RANGE 8-12 MICRONS  
 MAXIMUM VERTICAL SCALE +/- 200 MICRONS

*Fig. 70*