

(No Model.)

7 Sheets—Sheet 1.

W. WAGNER.
CAN SEAMING MACHINE.

No. 523,091.

Patented July 17, 1894.

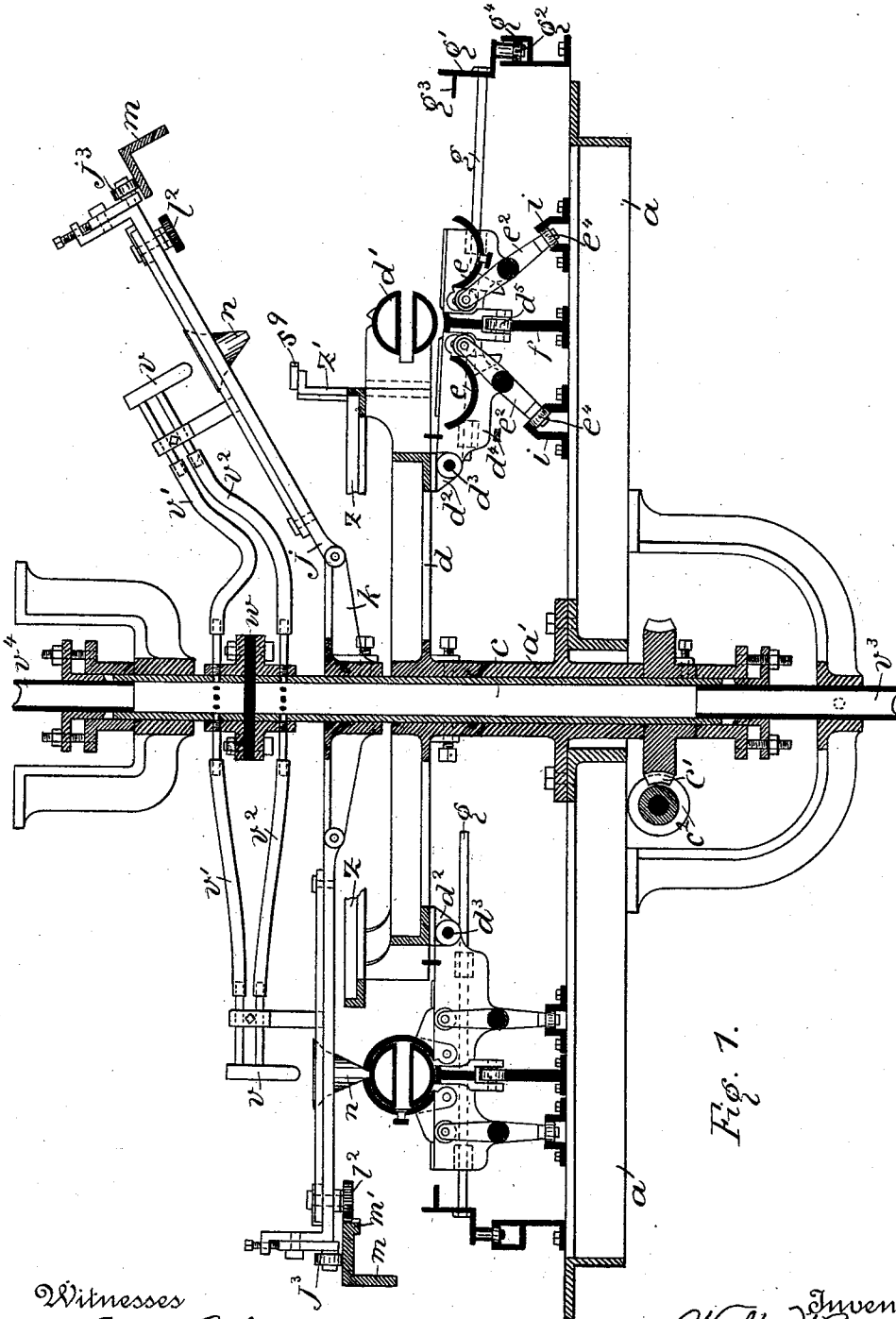

Fig. 7.

Witnesses
R. L. Roberts
J. A. Redelings

Inventor
Walter Wagner.
By his Attorney
Wm. Zimmerman.

(No Model.)

7 Sheets—Sheet 2.

W. WAGNER.
CAN SEAMING MACHINE.

No. 523,091.

Patented July 17, 1894.

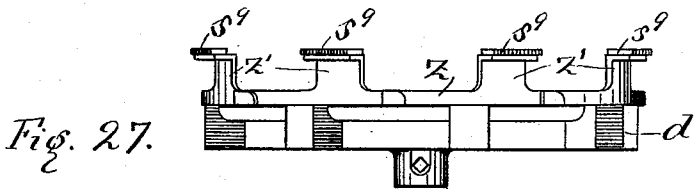
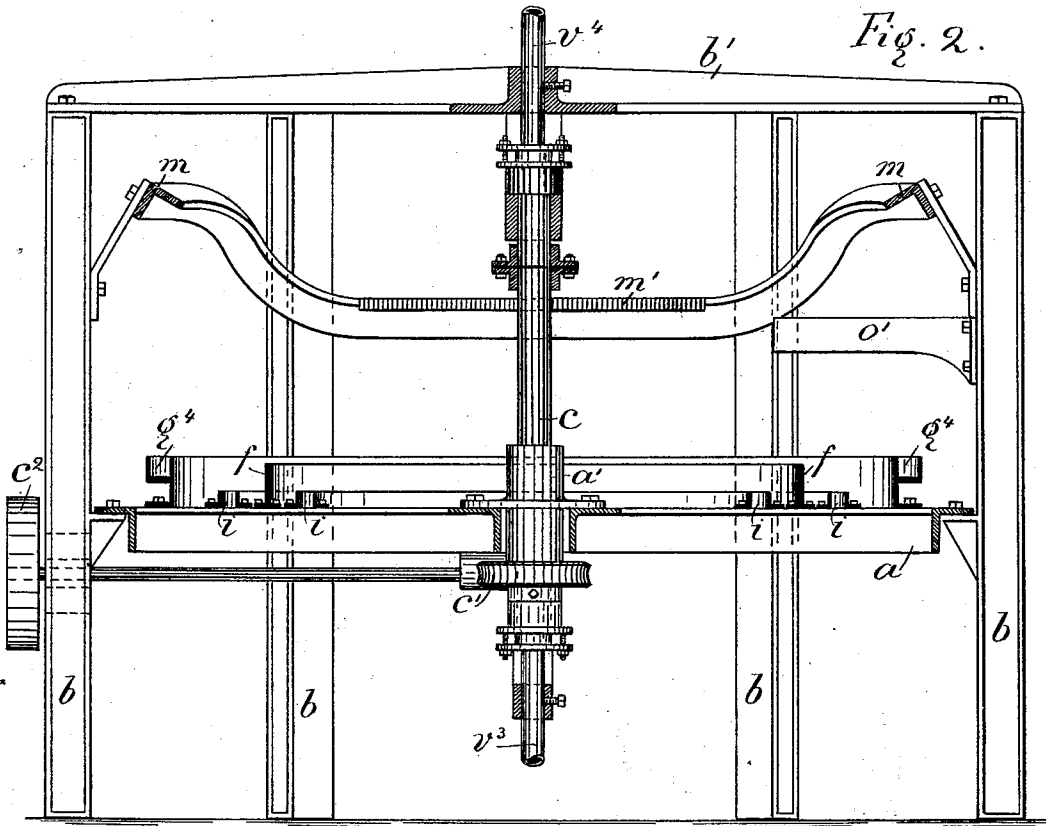

Witnesses
R. S. Roberts.
J. H. Padelung.

Inventor
Walter Wagner
 By his Attorney
W. Zimmerman.

(No Model.)

7 Sheets—Sheet 3.

W. WAGNER.
CAN SEAMING MACHINE.

No. 523,091.

Patented July 17, 1894.

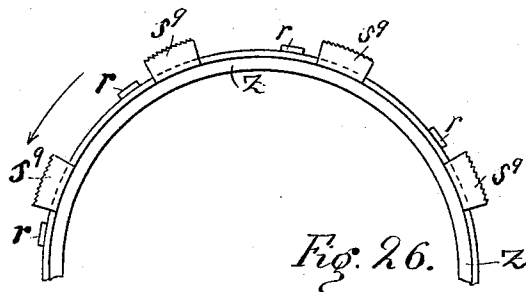
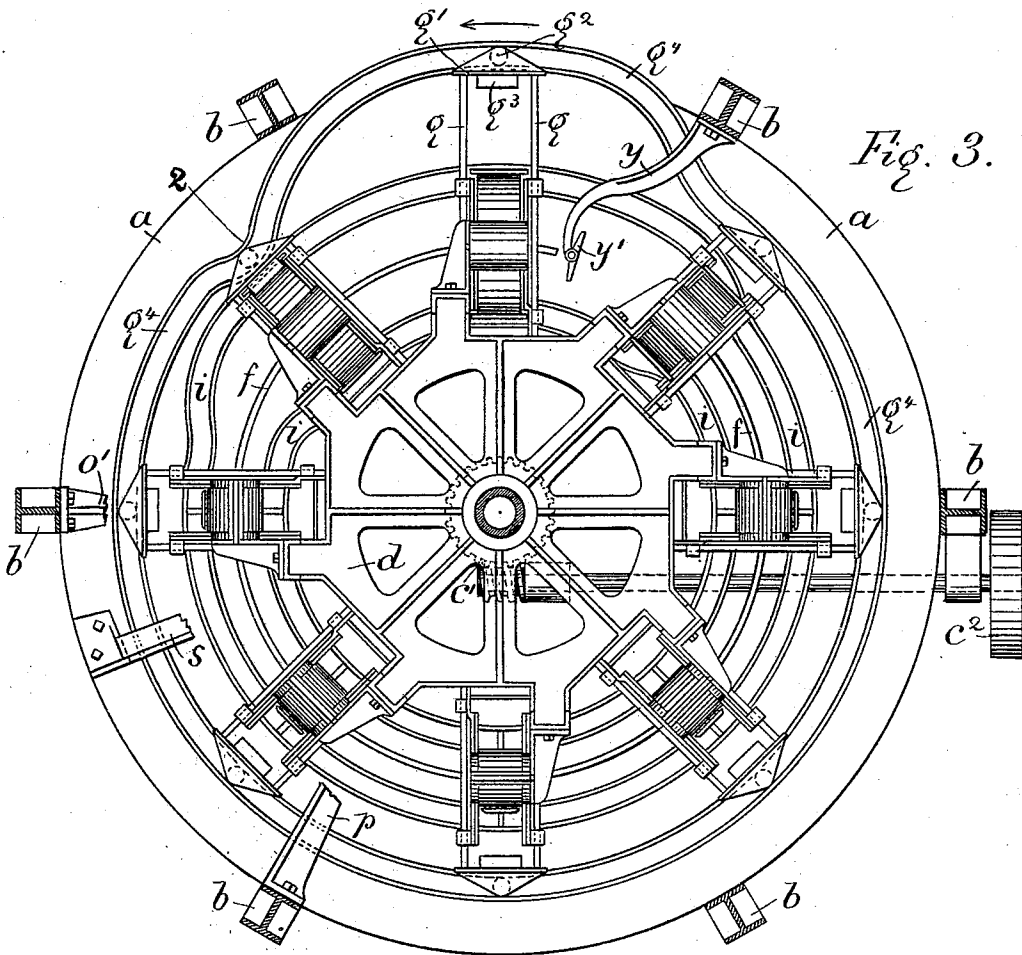

Witnesses

R. L. Roberts
J. M. Redding

Inventor
Walter Wagner.
By his Attorney
Wm. Zimmerman

W. WAGNER.
CAN SEAMING MACHINE.

No. 523,091.

Patented July 17, 1894.

Fig. 4.

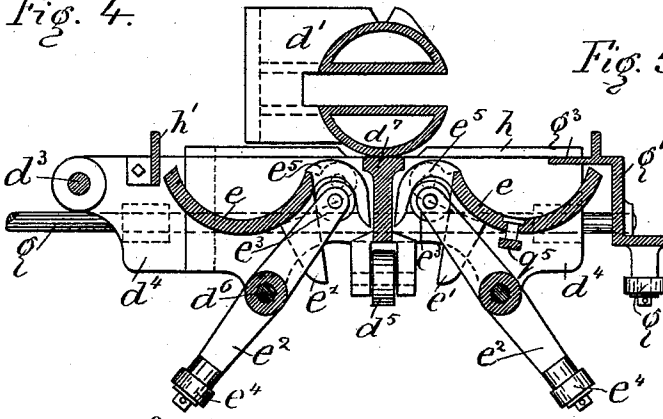

Fig. 5.

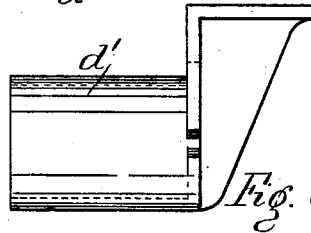
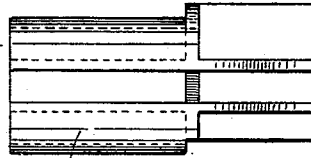

Fig. 6.

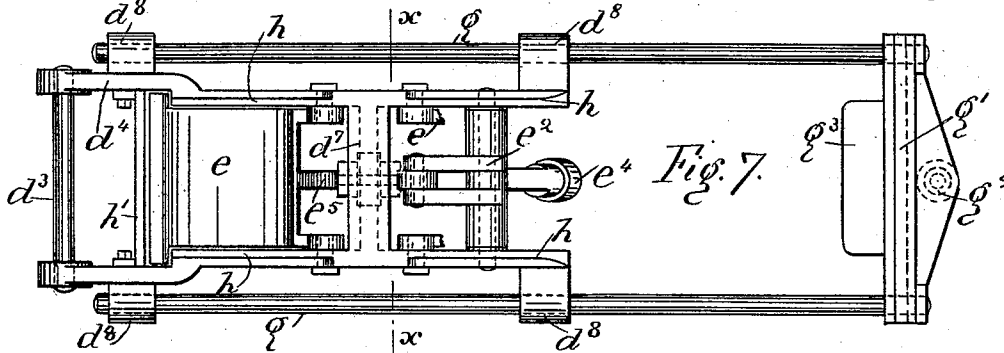

Fig. 7.

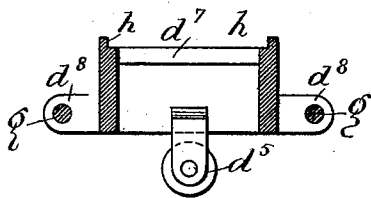

Fig. 10.

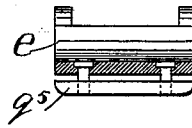

Fig. 8.

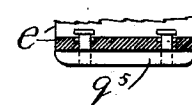

Fig. 9.

Witnesses

R. L. Roberts
J. N. Redding

Inventor

Walter Wagner

By his Attorney

Wm. Zimmerman

W. WAGNER.
CAN SEAMING MACHINE.

No. 523,091.

Patented July 17, 1894.

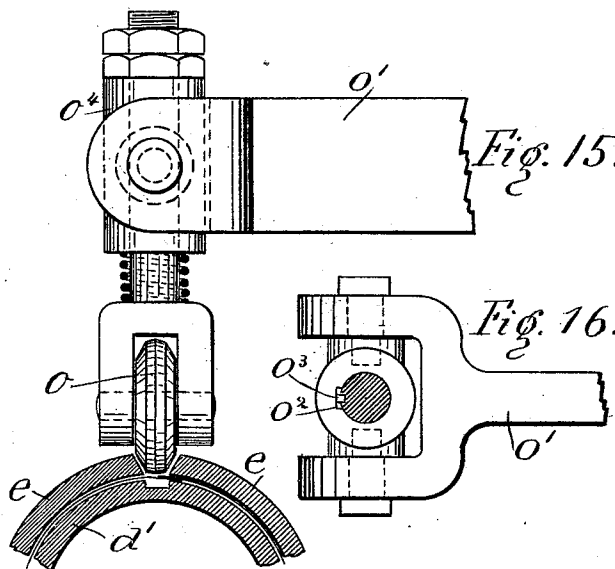
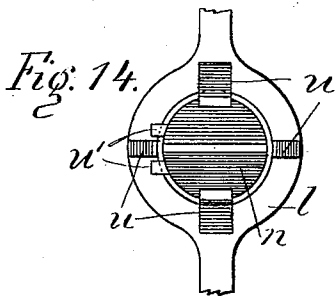
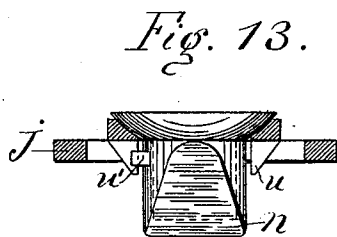
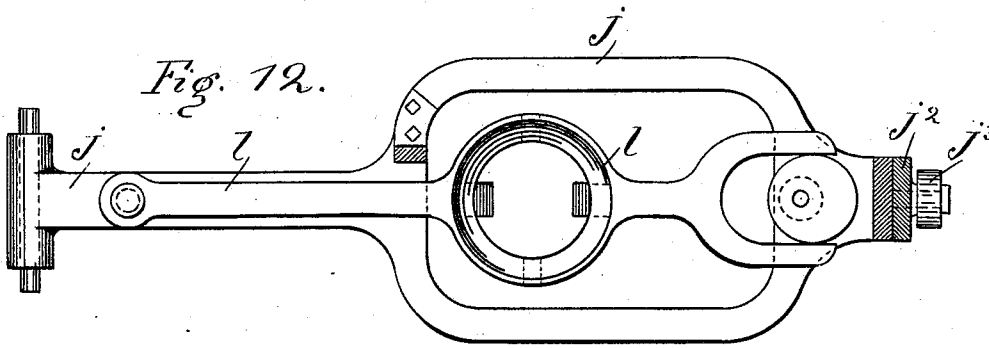
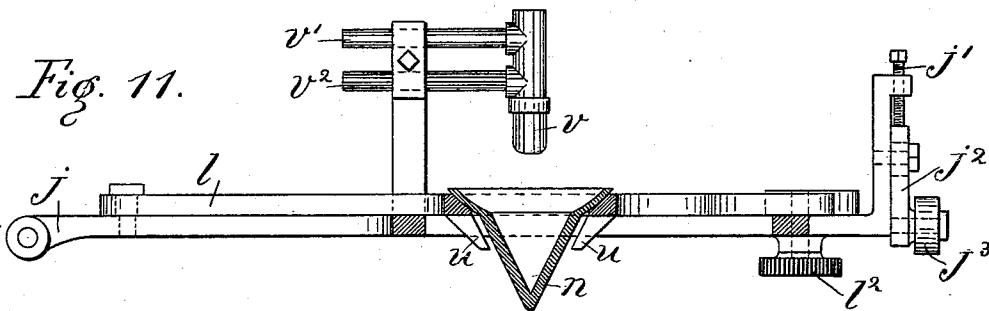

Witnesses

R. L. Roberts
J. H. Redding

Inventor
Walter Wagner
By his Attorney
Wm Zimmerman

W. WAGNER.
CAN SEAMING MACHINE.

No. 523,091.

Patented July 17, 1894.

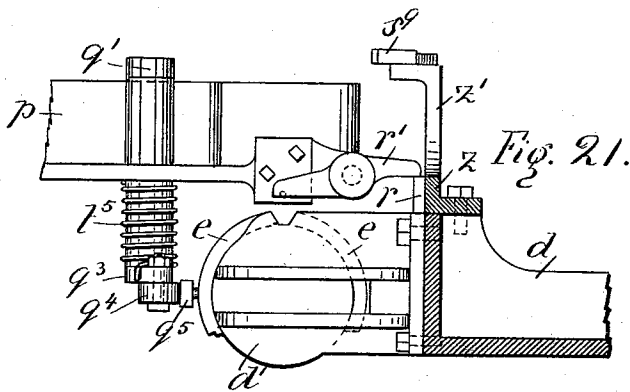
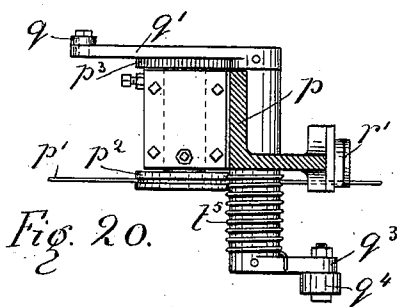
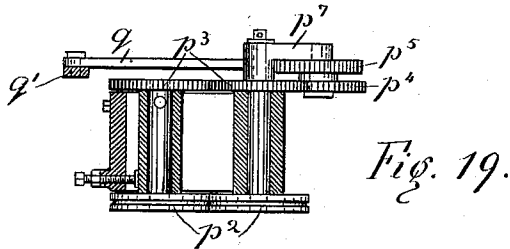
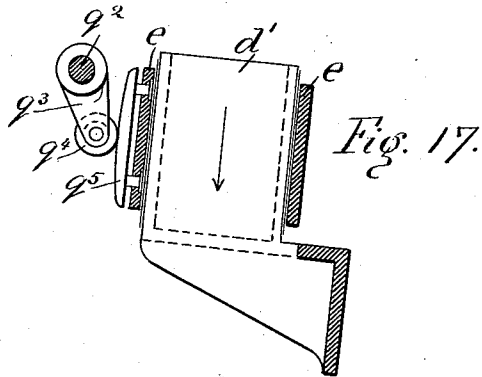
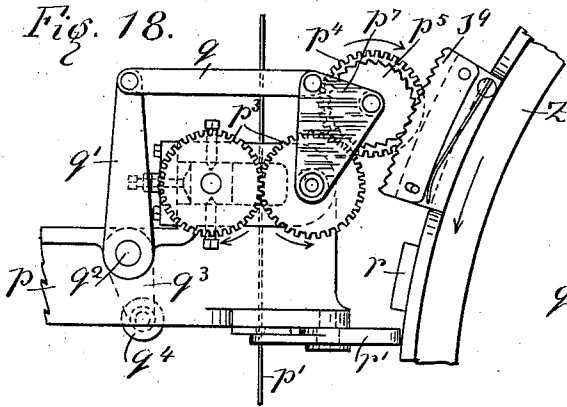

Witnesses

R. L. Roberts
J. H. Rudelings

Inventor

Walter Wagner

By His Attorney

Wm. Zimmermann.

W. WAGNER.
CAN SEAMING MACHINE.

No. 523,091.

Patented July 17, 1894.

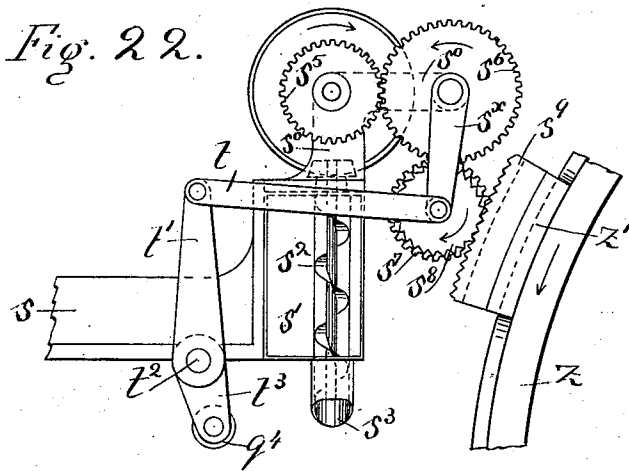

Fig. 23.

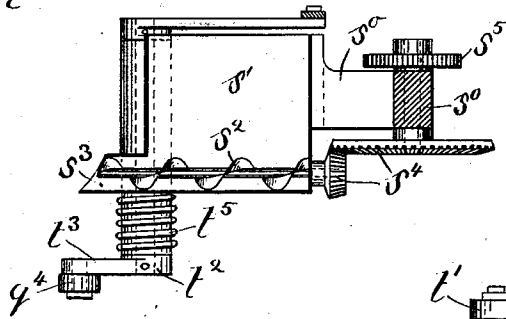

Fig. 25.

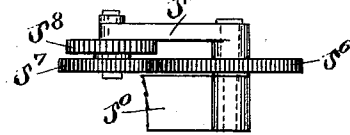
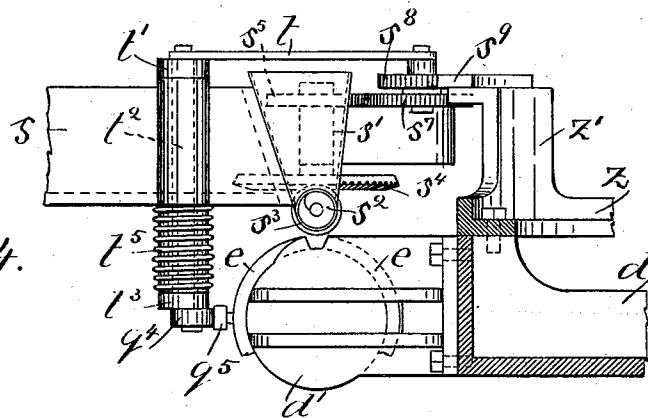

Fig. 24.



Witnesses

R. L. Roberts
J. H. Redding

Inventor

Walter Wagner.

By his Attorney

Wm Zimmerman.

UNITED STATES PATENT OFFICE.

WALTER WAGNER, OF CHICAGO, ILLINOIS.

CAN-SEAMING MACHINE.

SPECIFICATION forming part of Letters Patent No. 523,091, dated July 17, 1894.

Application filed September 25, 1893. Serial No. 486,458. (No model.)

To all whom it may concern:

Be it known that I, WALTER WAGNER, a citizen of the United States, residing at Chicago, in the county of Cook and State of Illinois, have invented certain new and useful Improvements in Can-Body Side-Seam-Soldering Machines, which are fully set forth in the following specification, reference being had to the accompanying drawings, forming a part hereof, and in which—

Figure 1 shows a central vertical section of my can-soldering machine, showing, principally, the parts attached to the central shaft and one mandrel and former open to receive a can-body and the other closed and in the act of soldering the side seam of a can-body. Fig. 2 shows a central vertical section taken at right-angles to that of Fig. 1. The central shaft is not in section. It also shows the posts which support the mechanism and their connections. Fig. 3 shows my said device in plan view, all parts above the wheel, *d*, being removed. Fig. 4 shows the mandrel and open former with its operating mechanism in end view. Fig. 5, shows a mandrel and its supporting bracket in side view. Fig. 6 shows Fig. 5 in plan view. Fig. 7 shows the former in plan view with one of its wings removed to expose the operating mechanism below and the mechanism which holds the metal sheets to be fed to the machine. Fig. 8 shows a longitudinal section of a former with an attached cam in its outer position. Fig. 9 shows a longitudinal section of a former, part broken away, with an attached cam in its closed position. Fig. 10 shows a cross-section through Fig. 7 on the plane *x, x*. Fig. 11 shows the arm carrying the soldering-bit in side elevation, partly in section. Fig. 12 shows the arm carrying the soldering-bit, in plan view, cut by a horizontal plane above said bit and the parts above said plane removed. Fig. 13 shows a transverse vertical section of Fig. 12 through the center of the soldering-bit without cutting said bit. Fig. 14 shows a plan view of the soldering-bit from its point, or, under side and a part of the arm which carries it. Fig. 15 shows, in end view, fragments of the formers and a part of a can and mandrel in closed position and, in side view, a device for compressing the lap of the can-edges. The coiled spring

of said device being shown in section, only a part of its supporting arm is shown. Fig. 16 shows the compressing device, shown in Fig. 15, in plan view. Fig. 17 shows a mandrel in plan view, with formers closed on it, in central longitudinal section, and attached to one of said formers a cam with end view of a shaft with an arm and roller on end of said arm. Fig. 18 shows in plan view the soldering wire feeding and cutting mechanism in operating contact with its actuating device. Fig. 19 shows a section of Fig. 18 taken on a plane which would cut the axes of the wire-feeding rollers, the gears, rollers, set-screw and shafts being uncut thereby. Fig. 20 shows Fig. 18 in elevation, as seen from the outer side of the machine. Fig. 21 shows Fig. 20 in front view. Fig. 22 shows the rosin-feeding device in plan view, in operating contact with the driving mechanism. Fig. 23 shows a longitudinal section of the rosin-feeding mechanism, as seen from the inside of the machine, the arm, or bracket, *s*⁰, being broken between *s*⁵ and *s*⁶ and removed from the other parts. Fig. 24 shows Fig. 22 in front view together with a mandrel and fragments of the wheel to which it is attached. Fig. 25 shows a side view of the end of the arm *s*⁰ removed from Fig. 23. Fig. 26 shows, in plan view, one half of a wheel, *z*, on the wheel, *d*, carrying cam shaped racks. Fig. 27 shows cam shaped racks and the wheels *d* and *z* in side elevation and connected.

Like letters of reference denote like parts.

The object of my invention is to solder, by machinery, the side seams of can-bodies in continuous circular motion, and to attain said desirable result I construct my said new device in substantially the following manner, namely:

Centrally, on a circular table, *a*, supported on posts, *b*, held together at their top by a spider *b*¹, is placed a vertical shaft, *c*, pivoted in said spider, and actuated by a worm-gear, *c*¹, driven by a pulley, *c*². Centrally to and on said table is bolted a flanged hub or tubular guide, *a*¹, extending down through it to the gear, *c*¹, and up to the hub of a wheel *d*. Said wheel, *d*, carries a series of fixed centrally and longitudinally slotted mandrels *d*¹, tangent to a circle with axes in the plane thereof. The ends of said mandrel are parts

of brackets which are bolted to the wheel, d . Through lugs, d^2 , on wheel, d , passes a rod, d^3 , on which are hinged side-pieces, d^4 , and between said sides are hinged wings, or formers, e . The sides, d^4 , are connected by a bar d^7 having a roller, d^5 , which runs on a circular track, f , having a cam-shaped surface, and, in lugs, d^3 , on the outside of the sides d^4 , are reciprocating rods, g , which carry on their 10 outer ends a head, g' , having a depending spur with a roller, g^2 , and on its inner side, a shelf, g^3 . On the upper and inner edges of the sides, d^4 , are offsets with stops, h , and near the rear end of the sides d^4 is a transverse 15 stop, h' . The vertical part of the head, g' , and its shelf, g^3 , together with said offsets and stops, h and h' , serve to receive and hold in proper place the flat sheet for forming the can-body. Cams, e' , e^5 , form a part of the 20 wings, e , and on each side of their hinge-centers, are actuated by rollers, e^3 , in the ends of forked levers, e^2 . Said levers are fulcrumed between their ends on shafts d^5 , in the side-pieces, d^4 . The lower ends of said levers have 25 rollers, e^4 , turning on the axes of said levers, and moving in slotted cams, i , on each side of the track, f . Said cams, i , approach and recede from each other and thus cause said levers to oscillate and move the cams, e' , e^5 , 30 and thus open and close the formers, or wings, e , about the mandrel d' .

When a flat can-body is placed, as aforesaid, the mandrel, d' , cross-bar, d^7 , and sides, d^4 , are apart, as shown on the right hand side 35 of Fig. 1, the cam, f , being low at that part of its circle. As said parts advance, the track, f , rises and thus it raises said bar d^7 and wings e , up snug against the mandrel, d' . At the same time the cam-shaped tracks i approach 40 and thus cause the formers, e , to close, as shown on the left hand side in Fig. 1, where the can-body is formed and held between the mandrel and its formers ready to be soldered. The free ends of said formers, when 45 closed, are apart far enough to admit the application of a soldering-bit on the joint of the can-body.

When the head, g' , has been moved to its extreme outer position by means of the cam, 50 g^4 , and roller g^2 ,—immediately under the arrow—Fig. 3,—the flat can-body is laid on the shelf g^3 , against the head, g' , and between the stops, h . In its onward motion the cam, g^4 , pushes the head and its can-body inward 55 until it gets to its next, and extreme inward position, 2, where the can-body meets the stop, h' . At this point the bar, d^7 , begins to hold said can-body, then the head, g' , again moves outward, somewhat abruptly, from, 2, 60 (Fig. 3) to give room for the former, e , under it, to rise. The cams, i , and levers, e^2 , now begin to close the formers, e , on the mandrel. As soon as they are closed said mechanism passes under a roller, o , on a shaft in a trun- 65 nioned sleeve held by an arm, o' , attached, at the proper place, to some part of the frame or other suitable part of the machine. Said

roller serves to lay the lapping edges of the can-body flatly upon each other. Its plane of motion is limited by the slot, o^2 , and spline, 70 o^3 . A spring to give yielding pressure is between said sleeve and roller, o , and set nuts, or an equivalent device holds its outer end on said sleeve.

Beyond the roller, o , on arm, s , fixed to a 75 suitable support, is the mechanism for supplying powdered rosin to the joint to be soldered. It consists of a wedge-shaped box, s' , with a worm, s^2 , in its sharper end having a spout, s^3 , parallel to the joint to be soldered. 80 Said worm turns on its axis by bevel gears, s^4 , of which the larger wheel is held on a shaft in a right-angled arm, s^0 , of said box, and said shaft has, at its other end, a gear-wheel, s^5 , actuated by a gear-wheel, s^6 , also held by said 85 arm, and above said wheel and on its shaft, is an arm, s^x , having a pivot at its outer end on which turns the gear, s^7 , which meshes into, s^6 , and to it is fixed the pinion, s^8 , which meshes with the rack, s^9 , carried on the wheel 90 z . A bar, t , connects the free ends of the arms s^x , t' . Said arm t' turns a shaft, t^2 , which carries at its lower end a short arm, t^3 , having a roller, q^4 , at its outer end which makes contact with and is actuated by the 95 cams q^5 , on the formers, e , and causes pinion, s^8 , and rack, s^9 , to mesh and actuate said gear and worm. Said rosin-supplying mechanism and the mandrels, d' , are placed so as to bring the roller, q^4 , in contact with a recip- 100 rocating cam, q^5 , on the outer ends of two loose and headed pins passing through the outer one of a pair of formers, e , which are countersunk for said heads. When a can- 105 body is held by the formers said pins are pushed and held in their outer position by such can-body, then the cam, q^5 , pushes the roller q^4 outward thus throwing the arm, t' , inward and causing the pinion, s^8 , to engage the rack, s^9 , and thus set said train of gearing 110 and worm, s^2 , into action. An arm, p , also attached to some part of the frame or other stationary part of the machine, succeeding the arm, s , carries the solder-feeding mechanism, the solder, preferably, being in the form 115 of a wire which is fed by a pair of duplicate grooved rollers, p^2 , on a pair of shafts with a pair of duplicate gear wheels, p^3 , at the other end of said shafts. A gear wheel, p^4 , meshes into one of said gear-wheels, p^3 , and to it is 120 fixed a pinion, p^5 , which meshes into a rack, s^9 , on the wheel z .

Loosely pivoted on the outer end of one of the shafts of the gears, p^3 , is an arm, p^7 , which expands at its outer end and carries the shaft 125 of the wheels, p^4 , p^5 , and a pin to which one end of a bar, q , is connected, its other end being pivoted to an arm, q' , fixed to the shaft, q^2 , which, at its lower end, has a short fixed arm, q^3 , with a roller q^4 at its outer end. Said 130 roller, q^4 , is moved by the cam, q^5 , when the latter is pushed to its outer position by a can-body in the formers and thus the solder-wire feeding mechanism is set into action in like

manner as already shown that it acts for the rosin-feeding mechanism.

When, accidentally, no can-body is held in the formers neither the rosin nor solder-feeding mechanism is thrown into action. The coiled spring b^5 , forces the cam q^5 to its inner position, the heads of the pins which hold it passing into the large slot of the mandrel, d' , and thus no contact of either mechanism is made with said rack, s^9 . A cam, r , on the wheel, z , actuates the shears, r' , to cut off the wire solder, p' . The joint thus prepared is now touched by the hot soldering-bit, n , carried in the compound arms, j , l , of which the former is hinged to the disk, k , so as to play vertically, while the arm, l , is hinged on the arm, j , so as to play horizontally on it; the joints of said arms being near each other. Said bit, n , is wedge-shaped near its lower end but its upper end is cylindrical and provided with a flange of which the surface which rests on the arm, l , is spheroidal, and its seat in said arm of corresponding form, and said arm is provided with four lugs, u ,—two on the vertical and two on the sloping sides of said bit and on each side of one of the former lugs are lugs, u' , on the bit, n , spaced so as to allow to it a slight axial motion to accommodate itself to the circular motion of the joint of the can.

Between the outer end of the forked arm, l , is an eccentric the shaft of which runs in a box in the arm, j , and on the lower end of the shaft there is a pinion, l^2 , which plays in the rack-teeth m' , of the circular cam, m . This mechanism gives a longitudinally reciprocating motion to the bit, n , in addition to its other adjusting motions. Near the outer end of the arm, j , there is a large opening in which said bit has free play. The arm, j , rises vertically at its outer end and has a flange through which passes an adjusting-screw, j' , upon a plate, j^2 , held and fastened to said upright end by a bolt passing through a slot in it into said upright end and carrying at the lower end thereof a roller, j^3 , which runs on a cam-shaped track, m , and thereby said bit, n , is raised from and lowered to the work at proper time and place.

The bit, n , is a shell, heated from above by a burner, v , supplied with air through the upper pipe, v' , and with gas through the lower pipe, v^2 . The air and gas are supplied through the hollow shaft, c , which is divided by a diaphragm, w , below which the gas is received through a tube, v^3 , held in the lower end of shaft, c , in a stuffing-box the gas passing through holes into the pipes, v^2 . The pipe, v^4 , enters the upper end of the shaft, c , through a stuffing-box and through holes in the pipe, c , passes the air through the tubes, v' , into the burner, v . A ring, z , is fastened upon the wheel, d . It is provided with short upright segments, z' , to which the racks, s^9 , are attached.

When the joint is soldered the formers e release the can-body, through the action of

the cams, i , and levers e^2 , and, shortly before finishing a complete circle a cross-bar, y' , centrally pivoted on the arm y , attached to a post, b , enters the slot of the mandrel, d' , and thus stops the can body and causes the mandrel to move out of it and the can-body to drop from the machine, finished, to receive its heads.

The formers to form the can-body on the mandrel are not indispensable as the can-bodies, already formed, may be slipped onto the mandrels.

It will be observed that there are as many soldering-bits as there are mandrels but there is only one compressing-roller o and one fluxing and solder supplying mechanism used, or necessary. The advantages thus attained over preceding devices are apparent, and at the same time it is easy to see that a single soldering-bit may be made to operate on succeeding cans, as do the fluxing and other devices mentioned.

The advantages gained by giving an intermittent motion to my mandrels, are: that it requires much less power to work the machine, therefore it can be built lighter and cheaper and be run at a far higher speed than when it has to move and stop step by step for the various operations and, finally, because intermittent and jerky motions injure the freshly soldered joint. I avoid, in a great measure at least, all the above difficulties.

What I claim is—

1. The combination with a continuously moving mandrel, of fixed solder supplying mechanism and a reciprocating soldering device, substantially as specified.
2. The combination with a mandrel moving continuously in a horizontal circle of fixed solder-supplying and a reciprocating soldering device, substantially as specified.
3. The combination with a series of mandrels moving continuously in a horizontal circle, of fixed solder-supplying mechanism and a reciprocating soldering device, substantially as specified.
4. The combination with a mandrel and soldering mechanism thereto moving together on a fixed center, of fixed flux and solder supplying mechanism and mechanism moving with said mandrel to actuate said flux and solder supplying mechanism, substantially as specified.
5. The combination with a horizontal and continuously moving mandrel, and soldering-bit, of fixed flux and solder-supplying apparatus and mechanism moving with said mandrel to actuate said flux and solder supplying mechanism, substantially as specified.
6. The combination with a mandrel and former provided with a reciprocating cam actuated by the can-body of fixed solder supplying mechanism actuated by said cam, substantially as specified.
7. The combination with a continuously

moving mandrel and fixed solder-supplying mechanism, of a soldering-bit moving with said mandrel, substantially as specified.

8. The combination with a continuously moving mandrel and fixed mechanism to compress the joint and supply it with soldering substances, of a soldering-bit with automatically adjusting edge substantially as specified.

9. The combination with continuously moving mandrels and formers therefor operated by levers fulcrumed between their ends, of cams to operate said levers, substantially as specified.

10. The combination with a continuously moving mandrel and formers to close thereon, of a fixed roller to compress the lap of the can-edges, substantially as specified.

11. The combination with a continuously moving mandrel and formers to close thereon, of fixed rosin supplying mechanism above the can-body and moving mechanism to actuate said rosin-supplying mechanism, substantially as specified.

12. The combination with a continuously moving mandrel and formers to close thereon, of fixed solder-supplying mechanism above the can-body and moving mechanism to actuate said solder-supplying mechanism, substantially as specified.

13. The combination with a continuously moving mandrel and formers to close thereon, of fixed rosin and solder supplying mechanism above the can-body, substantially as specified.

14. The combination with a continuously moving mandrel and formers to close thereon, of a fixed roller to act on the lapped edges of the can, a fixed rosin and a fixed solder supplying mechanism, in the order named, substantially as specified.

15. The combination with a continuously moving mandrel and vertically reciprocating side-pieces with formers to said mandrel, of a cam-shaped track, to operate said side-pieces, and levers, fulcrumed between their ends, actuated by cams, to operate said formers, substantially as specified.

16. The combination with a moving mandrel, of reciprocating side-pieces with formers and a reciprocating head, centrally fulcrumed levers to said formers, and cams to reciprocate said side-pieces, head, and levers, substantially as specified.

17. The combination with a mandrel, of hinge-operated side-pieces operating therewith, with offsets and stops on their upper edges, and formers to said mandrel on said side-pieces, a reciprocating head to said side-pieces and levers to said formers and cams to actuate said side-pieces, formers and head, substantially as specified.

18. The combination with a hollow gas-supplied shaft and moving mandrel thereon of doubly hinged formers to said mandrel, and

a soldering-bit and burner thereto, substantially as specified.

19. The combination with a hollow gas supplied shaft and moving mandrel thereon, of formers to said mandrel, mechanism to supply rosin and solder, a soldering-bit and burner, substantially as specified.

20. The combination with a hollow diaphragmed, gas-supplied shaft and mandrel thereon, of formers to said mandrel, and mechanism to compress the lap of the joint and supply it with rosin and solder, a solder-bit and burner thereto, substantially as specified.

21. The combination with a gas-supplied tubular shaft, of connected burner and soldering bit receiving gas from said shaft, substantially as specified.

22. The combination with gas-supplied tubular diaphragmed shaft, of connected burner and soldering bit moving together, substantially as specified.

23. The combination with a tubular gas-supplied shaft, of connected burner and soldering-bit, and mandrel and formers therefor, substantially as specified.

24. The combination with a moving and slotted mandrel and formers therefor, of a fixed arm to pass through said slot substantially as specified.

25. The combination with a continuously moving mandrel and reciprocating former-holder thereto, of formers on said holder, substantially as specified.

26. The combination with a continuously moving mandrel and fixed mechanism supplying soldering substances of a reciprocating soldering device, substantially as specified.

27. The combination with a moving mandrel, of a conjointly moving vertically and longitudinally reciprocating and laterally adjusting soldering edge, substantially as specified.

28. The combination with a moving mandrel, of a conjointly moving vertically and longitudinally reciprocating soldering edge, substantially as specified.

29. The combination with a mandrel, of a vertically and longitudinally reciprocating and laterally adjusting soldering edge, substantially as specified.

30. The combination with unintermittently moving mandrel with formers, of reciprocating feeding mechanism, substantially as specified.

31. The combination with a mandrel and formers opening and closing thereon, of reciprocating feeding mechanism moving transversely to said mandrel, substantially as specified.

WALTER WAGNER.

Witnesses:

WM. ZIMMERMAN,
WM. E. CLARKE, Jr.