

March 8, 1966

R. E. ZURACKI

3,238,822

FUSE HANDLING TOOL

Filed Sept. 30, 1963

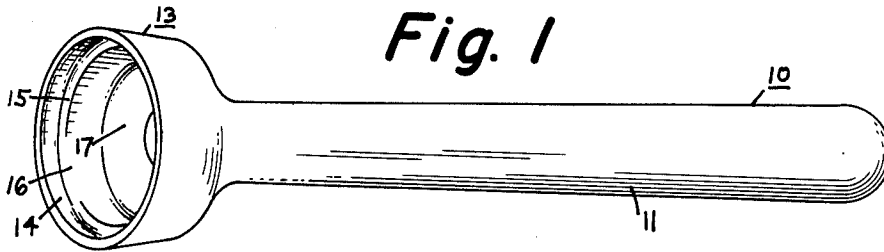

Fig. 1

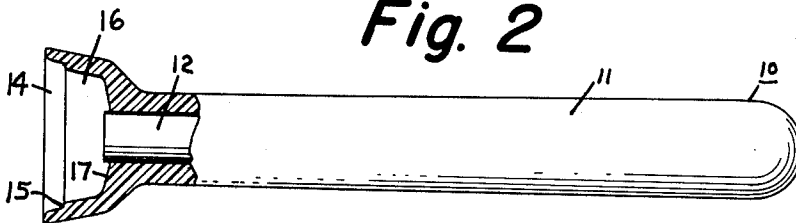

Fig. 2

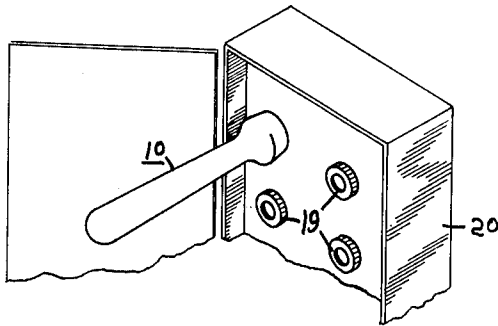

Fig. 3

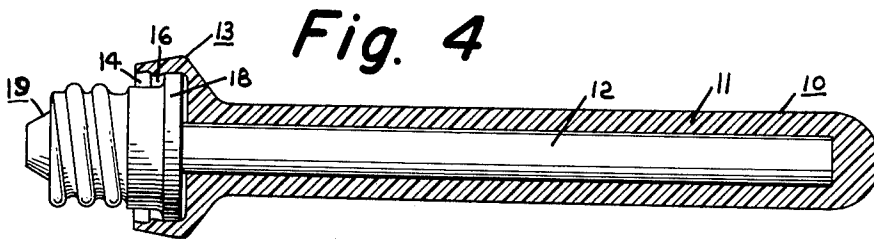

Fig. 4

INVENTOR.
ROBERT E. ZURACKI
BY
Halter B. Udell
ATTORNEY

3,238,822

FUSE HANDLING TOOL

Robert E. Zaracki, Philadelphia, Pa., assignor to Inventors League, Inc., Philadelphia, Pa., a corporation of Pennsylvania

Filed Sept. 30, 1963, Ser. No. 312,448

1 Claim. (Cl. 81—3.8)

This invention relates generally to electrically insulated gripping tools, and more particularly, relates to a tool for extracting burned-out threaded plug type fuses and installing new ones in fuse boxes.

The extraction and replacement of fuses can be a dangerous matter if reasonable precautions are not exercised, as for example by shutting off the electricity prior to attempting to change a fuse. While such a precaution would appear to be relatively simply carried out, the fact remains that in general it is not and many people have been seriously hurt or killed as a consequence. Unfortunately, fuses frequently blow out in residences during the course of the normal workday when the male members of the household, who are more likely to be able to safely change a fuse, are away at their occupations. The fuse changing problem is thus generally thrust upon the housewife. Some housewives are so fearful of replacing a fuse that they refuse to do so and wait many hours until they can have this attended to by others, in some cases even resorting to contacting the electric company. In other cases unsafe procedures are employed which may result in serious injury. The consequent loss of valuable time together with the inconvenience caused by waiting in the one case, and the possibility of serious injury in the other case are completely avoidable by employing an easily used, completely safe and very inexpensive gripping tool for threaded plug type fuses which makes it possible for anyone to quickly and safely replace a fuse of this type, the provision of such a fuse handling tool being a primary object of my invention.

Another object of my invention is to provide a novel fuse handling tool as aforesaid which has a working end and a handle extending therefrom, the working end being so constructed that it can be secured to and detached from a fuse by an operator gripping the handle at a distance from the working end so that no contact with the fuse or fuse box is necessary while removing or inserting the fuse.

Still another object of my invention is to provide a novel fuse handling tool as aforesaid which is completely formed of electrical insulating material to thereby prevent any possibility of electrical conduction from the fuse box to the hand of the tool operator while a fuse is being changed.

Yet another object of my invention is to provide a novel fuse handling tool which is so simple to use that no aptitude whatever for the use of tools is necessary.

The foregoing and other objects of my invention will become clear from a reading of the following specification in conjunction with an examination of the appended drawing, wherein:

FIGURE 1 illustrates a perspective view of the novel fuse handling tool according to the invention looking partly into the fuse gripping working end;

FIGURE 2 illustrates a side view of the novel fuse handling tool with the handle in elevation and the working end in longitudinal vertical section;

FIGURE 3 illustrates the tool grippingly engaged with a fuse in a fuse box, as would be the case both when extracting and installing a fuse; and

FIGURE 4 illustrates a longitudinal vertical section of the fuse handling tool with the working end grippingly engaged with a threaded plug type fuse and illustrating the resilient deformation of the working end by the gripped fuse.

In the several figures, like elements are denoted by like reference characters.

Briefly, referring to the figures, the invention contemplates the provision of a gripping tool having a resiliently deformable cup-shaped or frusto-conical working end which may be pushed axially onto the windowed end of a plug fuse so as to expand the seat region of the cup main well and cause the wall region of the cup which has been passed by the fuse end rim as the latter moves into the main well to contract radially inward about and thereby grip the end rim of the fuse. The fuse may then be rotated out of its socket by turning the handle of the tool. Once removed from the fuse box, the fuse may be pulled by hand axially out of the tool and a new fuse inserted into the tool. The new fuse is then screwed into the fuse box socket by rotating the tool until the fuse is firmly seated, whereupon the tool is removed by pulling it axially off of the fuse rim.

The tool is designated generally as 10 and includes an elongated generally cylindrical hollow handle 11 within which is disposed a rigidifying dowel 12, and a cup-shaped working end 13 molded integrally with the handle and extending axially from one end of the latter so that the plane of the open end of the cup is substantially perpendicular to the longitudinal axis of the handle 11. As best seen in FIGURE 2 the working end cup 13 includes an annular lip region 14 the inside wall of which extends axially convergently toward handle 11 for a short distance to a radially inwardly offset shoulder 15 which latter smoothly joins the lip region to the cup main well 16, the inside wall of the main well also extending axially convergently toward the handle 11 to the bottom wall 17 of the cup 13.

The maximum inside diameter of the annular lip 14 is such that it just accepts the rim 18 of a plug fuse, designated generally as 19 in FIGURE 4, and functions as a lead-in for the end of the fuse. As the tool 10 is pushed axially onto the windowed end of a plug fuse 19 installed in fuse box 20 as shown in FIGURE 3, the rim 18 is forced axially into the main well 16 of the cup and causes the wall thereof to expand radially. Since the maximum inside diameter of the main well 16 is less than the diameter of the fuse rim 18, as soon as the fuse rim has moved sufficiently toward the cup bottom 17 the expanded upper wall region of the main well 16 contracts radially inward behind the rim to firmly grip the same, as is most clearly seen in the showing of FIGURE 4.

Projection of the tool onto the plug fuse is terminated when the windowed end of the fuse seats against the end of dowel 12 which is observed to project slightly into the main well through the bottom wall 17, this also preventing turning of the fuse about any axis which would tend to disengage it from the cup 13. The dowel 12 is preferably made of any rigid electrical insulating material such as wood or plastic. Alternatively, the dowel may be dispensed with and the handle 11 molded of solid cross section.

Having now described my invention in connection with a particularly illustrated embodiment thereof it will be appreciated that variations and modifications of my invention may now occur from time to time to those persons normally skilled in the art without departing from the essential scope or spirit thereof, and accordingly it is intended to claim the same broadly as well as specifically as indicated by the appended claim.

What is claimed as new and useful is:

A fuse handling tool having a working end formed of electrical insulating material with resiliently radially expandable and contractable side walls which define a smooth relatively thin-walled hollow shell of generally frustoconical shape, said shell having an interior end wall at the smaller base end with the larger base end being

3

open, the smaller base interior end wall being of lesser diameter than the diameter of the windowed end of a plug fuse while the open ended larger base is of approximately the same diameter as the plug fuse windowed end, said open ended larger base defining gripping means for contracting radially inward behind the end rim of the fuse, and an elongated insulating material handle attached to the said working end, the length of said handle being sufficient to permit firm hand gripping thereof for manipulation of the tool end in a fuse box with the gripping hand spaced outward of and away from the fuse box, whereby said working end may be pushed axially onto the windowed end of a plug fuse with the open end functioning as a lead-in to guide the plug fuse into the hollow shell to a point immediately adjacent to the interior end wall so that the latter is radially expanded substantially to the diam-

5
10
15

4

eter of the fuse end rim, the shell side walls expanding to permit inward penetration of the fuse end and constricting radially thereabout behind the end rim of the fuse to a diameter less than that of the fuse end rim to thereby grip the latter.

References Cited by the Examiner

UNITED STATES PATENTS

1,954,422	4/1934	McIntyre	81-3.4
2,701,491	2/1955	Ross	81-64
2,743,640	5/1956	Verkuil	81-3.8 X
2,811,631	10/1957	Wood	81-3.8 X
2,985,045	5/1961	Grasty et al.	81-3.4

WILLIAM FELDMAN, *Primary Examiner.*
 MICHAEL BALAS, *Examiner.*