

R. Miller,

Making Springs.

No. 106,603.

Patented Aug. 23, 1870.

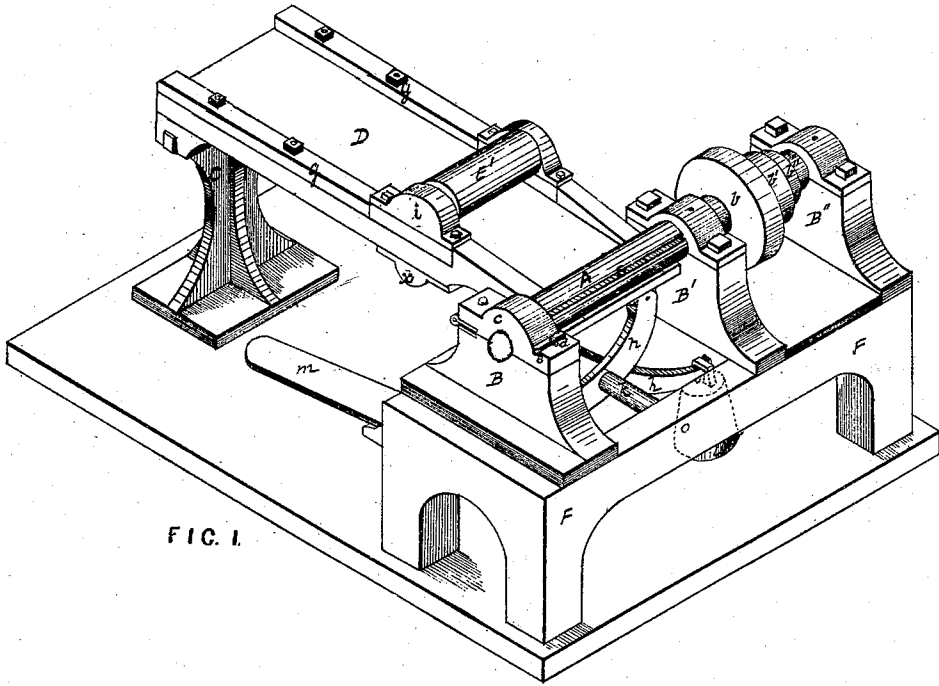

FIG. 1.

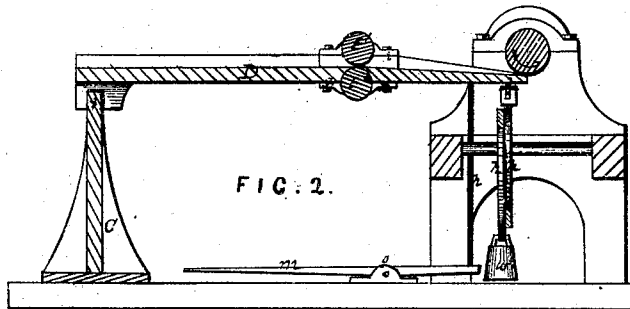

FIG. 2.

Witnesses:

R. Wrenshaw

E. C. Fidler

Inventor:

Reuben Miller

by his attorneys

Bakewell & Christy.

UNITED STATES PATENT OFFICE.

REUBEN MILLER, OF PITTSBURG, PENNSYLVANIA.

IMPROVEMENT IN MACHINES FOR BENDING VOLUTE SPRINGS.

Specification forming part of Letters Patent No. 106,603, dated August 23, 1870.

To all whom it may concern:

Be it known that I, REUBEN MILLER, of Pittsburg, in the county of Allegheny and State of Pennsylvania, have invented a new and useful Improvement in Machine for Bending Springs; and I do hereby declare the following to be a full, clear, and exact description thereof.

My invention relates to machinery for coiling or curling plates of steel or other metal into volute form, and is designed for making from sheets or strips of plate-steel volute springs.

To enable others skilled in the art to construct and use my improved machine, I will proceed to describe its construction and operation.

In the accompanying drawing, Figure 1 represents, in perspective, my improved machine. Fig. 2 is a longitudinal sectional elevation through the rolls and mandrel.

In both figures like letters are used to denote similar parts.

My machine consists, in part, of a table or bed, on which the sheet of steel is fed to the winding roller or mandrel between a pair of rollers. The end of the table at or under the mandrel while pressed up to its work is also susceptible of depression as the diameter of the volute on the mandrel increases.

In the drawing, F is the mandrel-frame, supporting three pillow-blocks, B B' B'', in two of which, B B', are the bearings of the mandrel A, and in the middle block, B', and the third one, B'', are the bearings of the shaft which carries the pulleys *b b' b''*, which is in the same horizontal axial line as the mandrel A. The axis of the mandrel A in the center pillow-block, B', is connected with the shaft of the pulleys *b* by a sleeve or socket or otherwise, so as to be revolved by the revolution of any one of the pulleys, (which are driven by a belt from a steam-engine or other prime motor, (so as to be easily detached in order to remove the finished volute wound around it.

In order to remove the mandrel A from the machine, the cap *c* of the pillow-block B is hinged at one end, as shown in Fig. 1, so that on raising it the journal of the mandrel A is exposed, and may be lifted out of its seat, when the journal at the other end can be drawn out from its connection with the pulley-

shaft in the pillow-block B'. The cap *c* on the pillow-block is fastened when in place by a slotted pin, *d*, and key *e*, as shown in the drawing.

The mandrel A is cylindrical, of such diameter as is required for the innermost curb of the volute spring, and has a slot, *s*, extending parallel to its axis the entire length of the mandrel, wide and deep enough to receive the forward edge of the sheet of steel to be worked, and hold it as it is being wound around by the revolution of the mandrel.

Opposite to the mandrel, and at a suitable distance for the length of the bed, is a stand, C, which supports the rear end of the feed-table D, and to which the table may be pivoted or hinged; or, if preferred, as an equivalent device, the top of the stand may have a straight rounded edge, which enters a groove in the under edge of the bed, the object being to support the bed, and at the same time allow of its being slightly raised or depressed at its forward end under or near the mandrel A.

The table has a plane upper surface, excepting that at each side is a strip, *g*, screwed down to the table, forming a ledge, the distance between these strips being such as to allow the plate of steel to pass freely between them over the table on its way to the mandrel, and yet close enough to keep the plate straight. These strips *g g* may be fastened down by bolts passing through slots in the table, so that their distance apart, forming the path of the steel, may be adjusted to any desired width.

At a short distance from the mandrel, across the table D, are fixed two small-diameter parallel rolls, E E', which are placed so as to be parallel to the mandrel A, the lower roll, E, having its bearings in caps *x*, attached to but under the table, so that the surface of the roll is very slightly above the surface of the table D, and the upper roll, E', has its bearings in caps *z*, projecting from and above the surface of the table D. These caps are attached to the table in any convenient manner, but so that they can be raised or lowered in order to increase or diminish the space between the rolls, and that thus their bite may be adjusted to the thickness of the steel plate which is to be curled by the machine.

From the farther extremity of the table to

the point where the rolls E E' are situated, the table D is straight and is placed horizontally, or nearly so; but from that point to the mandrel it inclines slightly downward.

As the steel plate is wound around the mandrel in forming a volute spring the diameter of the roll is increased, and, consequently it is necessary that the forward end of the table, at or under the mandrel A, should be gradually depressed. This is effected by the pressure of the coiled steel plate on the mandrel; but to permit of such depression, and yet keep the table up to its work as closely as possible to the mandrel A, its forward end is supported on props consisting of two levers, *h h'*, which cross each other on a shaft, *k*, which passes through them and forms their fulcrum. This shaft is rigidly attached to the frame F of the machine. The upper extremity of these levers may be furnished with friction-rollers *l l*, so as to permit of their working easily against the under side of the table D.

To the lower extremity of each of the levers *h h* is attached or suspended a weight, *w w'*, of sufficient gravity to keep the table up against the outer surface of the steel plate as it is being rolled around the mandrel, and cause the steel plate to bend closely around the mandrel. Were this not the case the steel plate would curl too loosely to form a good volute.

In order to regulate the degree of pressure, and increase it, if necessary, a treadle, *m*, hinged to the floor of the machine at *o*, is employed, having one or more rods, *p*, extending perpendicularly from the short end of the treadle to the under side of the table D, at or near its front end. The rod or rods *p* may, if preferred, be hinged to the table or to the treadle, or to both.

In lieu of the weighted levers and treadle for pressing the free end of the table up against the mandrel, a spring or springs may be placed under the end of the table, and bearing against the frame of the machine.

The operation of the machine is as follows: The strips *g g* being set at the proper distance

apart, the plate of steel to be wound is placed on the surface of the table D, passed under the rollers E E', and its forward end is inserted in the groove S in the mandrel A. The mandrel A is then caused to revolve in the direction indicated by the arrow in Fig. 2, so as not to raise the plate of steel from the table D, and the outer end of the treadle being depressed by the workman's foot, so as to give sufficient pressure (in addition to that of the weighted levers *h h'*) to cause the steel plate to be wound closely, the operation is continued until the entire length of the steel plate is wound on the mandrel A. When this is done the cap *c* of the pillow-block B is raised, and the mandrel, with the steel plate wound around it, is removed from the machine, and the mandrel being drawn out from the coiled steel plate, the machine is ready for a repetition of the operation on replacing the mandrel. Duplicate mandrels may be employed, so as to avoid detention while the volute spring is being removed from the mandrel.

I am aware that the combination of a slotted roll and a hinged feeding-table and mechanism to constantly force the table upward toward the roll is not new, nor do I claim said combination, broadly; but

What I do claim as my improvement of said combination is—

1. Constructing the groove of a width equal or about equal to the thickness of the metal, and attaching one of the roller journal-bearings to the pillow-block by a hinged cap, to permit the roll to be readily removed, substantially as set forth.

2. The combination of the slotted roller or mandrel A, the feed-rolls E E', hinged table D, and mechanism for applying an upward pressure to the table, substantially as set forth.

In testimony whereof I, the said REUBEN MILLER, have hereunto set my hand.

REUBEN MILLER.

Witnesses:

A. S. NICHOLSON,
THOS. B. KERR.