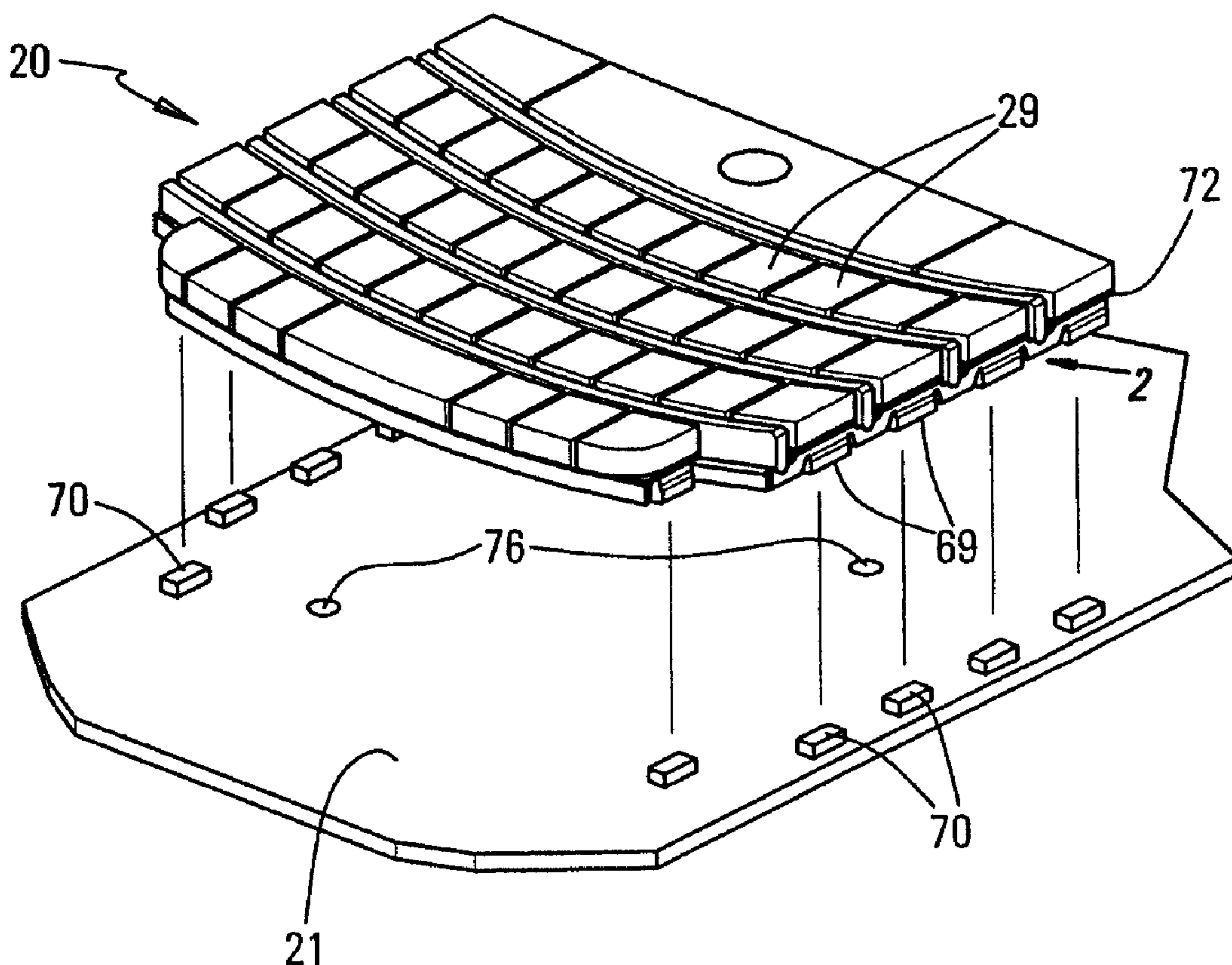




(22) Date de dépôt/Filing Date: 2008/09/05  
 (41) Mise à la disp. pub./Open to Public Insp.: 2009/04/29  
 (45) Date de délivrance/Issue Date: 2014/10/28  
 (30) Priorité/Priority: 2007/10/29 (EP07119553)

(51) Cl.Int./Int.Cl. *H01H 13/83* (2006.01),  
*F21V 33/00* (2006.01), *G06F 3/02* (2006.01),  
*H01H 13/705* (2006.01), *H01H 13/88* (2006.01),  
*H04W 88/02* (2009.01)  
 (72) Inventeurs/Inventors:  
 CHEN, CHAO, CA;  
 KYOWSKI, TIMOTHY HERBERT, CA;  
 PENNER, DENNIS J., CA  
 (73) Propriétaire/Owner:  
 BLACKBERRY LIMITED, CA  
 (74) Agent: BORDEN LADNER GERVAIS LLP

(54) Titre : PAVE NUMERIQUE LUMINEUX  
 (54) Title: ILLUMINATED KEY-PAD ASSEMBLY



(57) **Abrégé/Abstract:**

For a cell-phone or PDA, the rows of key-caps include respective light-strips, which pick up light from respective LEDs surface-mounted on the PCB. The light-strips are sandwiched between the key-caps and the key-switch actuators (whereby the light-strips move with the keys when the keys are depressed). Sockets for receiving the key-caps are co-molded to the light-strips. Sockets are provided in the resilient webs of the keys for receiving under-blocks co-molded to the light-strips.

**ABSTRACT**

For a cell-phone or PDA, the rows of key-caps include respective light-strips, which pick up light from respective LEDs surface-mounted on the PCB. The light-strips are sandwiched between the key-caps and the key-switch actuators (whereby the light-strips move with the keys when the keys are depressed). Sockets for receiving the key-caps are co-molded to the light-strips. Sockets are provided in the resilient webs of the keys for receiving under-blocks co-molded to the light-strips.

## **ILLUMINATED KEY-PAD ASSEMBLY**

### **FIELD OF THE INVENTION**

This technology relates to illuminated key-pads, especially of the kind as used in cell-phones, personal digital assistants (PDAs) and the like. Generally, such key-pads are illuminated by the use of transparent or translucent light-transmitting films or sheets, which receive light from a light emitting diode (LED) provided for the purpose, and powered by the battery in the PDA.

### **BACKGROUND OF THE INVENTION**

In traditional designs of illuminated key-pad units, the LED has been mounted in the key-pad unit itself, and has been connected to the main circuit board of the PDA by means of a flexible printed circuit (FCP) connector. In other designs, the light-transmitting film or light-guide has been placed underneath the whole key-pad unit; in these designs, in order for the light to reach the key-caps, the light had to pass through a number of components, whereby a significant proportion of the light was attenuated.

### **SUMMARY OF THE INVENTION**

In one aspect of the invention, there is provided an illuminated key-pad unit having depressible keys, comprising a base-frame; a set of keys mounted on the base-frame; a light-strip of transparent or translucent light-transmitting material; wherein the light-strip is capable of transmitting light received from a light source along the light-strip, and of radiating that light from an overface of the light-strip, and wherein the material of the light-strip is flexible, in that the light-strip can be repeatedly flexed and deflected, substantially without damage; and the overface of the light-strip is in a direct light-transmitting relationship with the set of keys.

In yet another aspect of the invention, there is provided procedure for manufacturing an illuminated key-pad unit, characterised by providing a plurality of depressible key-caps, in which each key-cap is of a transparent or translucent light-transmitting material; providing a corresponding plurality of key-switch-actuators, adapted for contacting respective key-switches mounted on a PCB; providing a light-strip, of such structure as to be capable of transmitting light received from a light-source, along the

light-strip, and of radiating that light from an overface of the light-strip; bonding the key-caps onto the overface of the light-strip; bonding the key-switch-actuators onto an underface of the light-strip; whereby the light-strip resides between the key-caps and their respective key-switch-actuators, and whereby the light-strip is depressed when the key-cap is depressed.

In yet another aspect of the invention, there is provided procedure for manufacturing an illuminated key-pad unit, characterised by including providing a plurality of depressible key-caps, in which each key-cap is of a transparent or translucent light-transmitting material; providing respective profiled under-buttons in the light-transmitting material of the key-caps; providing respective button-receiving sockets, profiled to receive the under-buttons; providing a light-strip, of such structure as to be capable of transmitting light received from a light source along the light-strip, and of radiating that light from an overface of the light-strip; and co-molding the button-receiving sockets to the overface of the light-strip.

In yet another aspect, there is provided an illuminated key-pad unit comprising a set of depressible keys mounted on a base-frame; and a light-strip of transparent or translucent light-transmitting material; wherein a physical structure of the light-strip is such that the light-strip is capable of transmitting light received from a light source along the light-strip and of radiating that light from an overface of the light-strip; wherein the keys comprise respective key-caps each comprising a molding of a transparent or translucent light-transmitting material and each comprising an over-surface, an under-surface, and a soft, springy and resilient web; the overface of the light-strip is in a face-to-face relationship with the under-surface of the key-cap; the overface of the light-strip is in a direct light-transmitting relationship with the under-surface of the key-cap; the material of the light-strip is flexible; and the under-surface of the key-cap is glued to the overface of the light-strip; whereby the light-strip is depressed when the key-cap is depressed, characterized in that the frame is configured as a grid, in that the frame comprises rails that define pockets respective to the key-caps between the rails; the webs are secured to the rails, and are arranged in the pockets defined by the frame.

In yet another aspect, there is provided an illuminated key-pad unit comprising a set of depressible keys, the keys comprising respective key-caps; a flexible web structure comprising block sockets; characterized in that at least one light strip comprises under-

blocks to engage the block sockets and a set of key-cap sockets, located on a top surface of the light strip, to engage the key caps.

In another aspect, there is provided an illuminated key-pad comprising a frame; a set of keys assembled in at least two rows and mounted on the frame; and at least two light strips disposed along the at least two rows of keys, the at least two light strips comprising a respective overface; characterized in that the at least two light strips are linked at their ends by respective linking straps; whereby the linking straps are formed with notches hooked under tenons formed in the frame.

### **BRIEF DESCRIPTION OF THE DRAWINGS**

By way of further explanation, an example of an illuminated key-pad unit for a PDA will now be described, with reference to the accompanying drawings, in which:

Fig. 1 is a pictorial view of an illuminated key-pad unit, shown in association with the circuit-board of the PDA in which the key-pad unit is to be fitted.

Fig. 2 is a sectioned-elevation on the line of the arrow 2 of Fig. 1.

Fig. 3 is a cross-section on the line 3-3 of Fig. 2.

Fig. 4 is a cross-section on the line 4-4 of Fig. 2.

Fig. 5 is a side elevational in the direction of the arrow 2 of Fig. 1.

Fig. 6 is a pictorial view of (part of) a light-strip component of the illuminated key-pad unit shown in Fig. 1.

Fig. 7 is a pictorial view of (part of) a frame component of the illuminated key-pad unit shown in Fig. 1.

## DETAILED DESCRIPTION OF PREFERRED EMBODIMENTS

The scope of the patent protection sought herein is defined by the accompanying claims.

The physical features described herein, although shown or described in respect of just one exemplary structure, should be understood as being applicable also to other structures, or as being interchangeable with corresponding features of other structures, unless otherwise stated, or unless such would be understood to be physically impossible.

Figs.1-7 show an illuminated key-pad unit 20 that is designed for assembly to a printed circuit board (PCB) 21, for installation in a PDA.

The key-pad unit 20 includes a rigid plastic frame 23. The frame includes rails 25 which define spaces or pockets 27 between the rails. The pockets 27 correspond each to a particular key of the key-pad unit 20.

The key includes a key-cap 29, which is formed as a molding of transparent or translucent plastic. The key-cap molding includes an under-button 30, of the same material. The visible outer surface 32 of the key-cap 29 is provided with a mask or coating 34. Windows 36 formed in the coating 34 allow light to shine through the key-cap, to display the letter or numeral etc appropriate to that key.

Light is supplied to the under-surface 38 of the under-button 30 via a light-strip 41. The light-strip 41 comprises a thin film (of the order of e.g 0.4 mm thick) of transparent or translucent material, which transmits light received at one location of the light-strip 41 throughout the material. Thus, light emerges from the overface 43 of the light-strip 41 and is transmitted directly into the under-surface 38 of the under-button 30 of the key-cap 29, and out of the windows 36 in the coating 34 of the key-cap 29.

The under-surface 38 of the under-button 30 is glued to the overface 43 of the light-strip 41, both to physically secure the key-cap 29 to the light-strip 41, and to ensure efficient transmission of light therebetween.

The light-strip 41 is provided with button-receiving sockets 45, which are shaped to hold the respective key-caps 29 in a predetermined positional relationship with respect to the light-strip 41. The socket 45 is rectangular, and the under-button 30 is profiled to fit inside the hollow interior of the rectangle, whereby, when the under-button 30 is received in the socket 45, the key-cap 29 is thereby prevented from movement laterally and rotationally relative to the light-strip 41. This mechanical constraint of the key-cap 29

ensures that the key-cap is glued to the light-strip accurately in its correct predetermined position.

The button-receiving socket 45 also serves other functions. The walls of the socket 45, being of opaque material, prevent leakage of light sideways out from the under-button 30. Also, the walls of the socket 45, especially if coloured white, serve to reflect light back into the under-button, and hence into the key-cap, whereby the light shining through the windows 36 is all the brighter. Also, the walls of the socket 45 serve as a tray, to catch any (liquid) adhesive that might be squeezed out from between the under-surface 38 and the overface 43.

An under-block 47 is attached to the underface 49 of the light-strip 41. The under-block 47 is of opaque and reflective material, which serves to prevent leakage of light out underneath the light-strip 41, and to reflect light back into the light-strip.

Just as the under-button 30 resided in the button-receiving socket 45, so the under-block 47 resides in the block-receiving socket 50. The socket 50 is formed in the middle of a membrane or diaphragm or web 52. The web 52 is co-molded or bonded onto respective ledges 54 on the rails 25 of the frame 23.

The web 52 is of a flexible material such as silicone rubber. The webs have enough inherent stiffness to hold the keys, when not pressed, in their correct relationships and positions. Thus, the inherent stiffness of the web 52 is enough to hold the thickened actuator portion 56 of the web 52, underneath the block-receiving socket 50, clear of the key-switch 58 on the PCB 21. On the other hand, it is very easy for the user to exert enough downwards force on the key-cap 29 to depress the key, and thereby to bring the actuator 56 into contact with the key-switch 58. The force required to depress the key, however, is large enough that the person can feel a resistance to the pressure of their finger on the key.

In many previous designs of key-pad unit, an under-button of the key-cap has engaged directly into a socket formed in the flexible web. By contrast, in the present design, the under-button 30 of the key-cap engages the socket 45 attached on top of the light-strip 41, and the under-block 47 attached underneath the light-strip 41 engages the socket 50 formed in the web 52. In the present design, by contrast, the light-strip 41 is interposed between the key-cap 29 and the flexible web 52. As such, it will be understood that the light-strip 41 is now called upon to move (downwards), and to flex, somewhat,

when the keys are depressed.

Thus, in the present design, the light-strip 41 should be flexible. But it is recognised that the light-transmitting material from which light-strips are typically made does have the desired degree of flexibility (that is to say, the ability to be flexed countless times without sustaining damage). In previous designs, the ability of the light-transmitting material to flex, and to move with the keys, has not been exploited, or not fully exploited.

In a typical key-pad unit, there are between e.g fifteen and e.g thirty or more keys, arranged in e.g four or five rows. In the present design, there are as many light-strips 41 as rows of keys. As shown in Fig.6, the several light-strips 41 are joined together at their ends, by means of linking straps 61. The straps 61 are formed on the ends of the light-strips 41, and may be regarded as joining the rolled-over ends of the light-strips.

The straps 61 are formed with respective notches 63, which engage underneath respective tenons 65 that are molded into the frame 23. Thus, for assembly, the straps 61 are stretched over, and snap underneath, the tenons 65.

Between the straps 61, the rolled-over ends of the light-strips 41 are formed with light-catchers 67. These light-catchers 67 comprise thickened areas of the light-strip material. The designer arranges that the respective under-faces 69 of the light-catchers 67, when the key-pad unit 20 is assembled to its PCB 21, lie positioned directly over respective light-emitting-diodes 70 attached to the PCB 21. Thus, light enters the light-strips 41 from the LEDs via the respective light-catchers 67.

The several light-strips 41 preferably are formed from a single flat sheet of light-transmitting material, in which the form of the light-strips is stamped out. The form of the linking-straps 61 is provided also by the stamping. For co-molding the button-receiving sockets 45, and the under-blocks 47, the sheet of light-transmitting material is laid in the mold, and then the sockets and blocks are formed by compression-molding. Preferably, the stamping of the sheet is done after the items have been co-molded onto the sheet. The light-catchers 67 also can be co-molded onto the sheet, preferably using clear or transparent rubber material.

As shown, the light-catchers 67 are somewhat thicker than the light-strips themselves. Thus, the light-catcher serves as a collecting hood, for collecting light from the LED. Typically, the light-catchers 67 would be one mm thick, where the light-strips 41 are thinner -- typically less than 0.4 mm thick, down to about 0.1 mm thick.

The key-pad unit 20 comprises the several key-caps 29, the linked-together light-strips 41, the frame 23 with its co-molded webs 52, and a light-shielding sheet 72. This key-pad unit 20 can be simply lowered into position upon the PCB, without the need for complex physical or electrical connections.

The light-shielding sheet 72 inhibits light from leaking out into the spaces between the keys. It is preferably made of strips of black plastic film, with cut-outs for the under-buttons 30, disposed respectively along the lengths of the rows of keys.

The LEDs 70 are surface-mounted devices, SMDs, which are simply and directly connected to the PCB 21. There is no expensive need for the LEDs to be furnished with e.g FPC connectors. The point is emphasised that the illuminated key-pad unit 20 is fully functional, with respect to the PCB 21, simply upon being placed in close proximity to the PCB, both as to actuating the PCB key-switches and as to receiving light for illumination. The key-pad unit is a self-contained sub-assembly, which can be finish-manufactured prior to being placed over the circuit-board during final assembly of the PDA.

The designer preferably should see to it that each light-strip 41 has its own respective LED 70; and indeed has its own respective pair of LEDs, one at each end of the light-strip. It will be understood that the LEDs, arranged thus, can be actuated other than in unison. Because the light-strips 41 are illuminated each by its own (pair of) LEDs, the different rows of keys can be illuminated e.g in patterns or cascades, and can be of different colours. Alternatively, especially in cases where the number of keys is small, it can be arranged that all the individual keys have their own respective individual light-strips, and their own respective LEDs.

Having the light-strips 41 in direct contact with the key-caps 29 means that the available light is used very efficiently: thus, the illumination can be brighter than has been the case with previous illuminated key-pads; or alternatively the electrical (battery) power needed to illuminate the keys can be significantly reduced; or the illumination can be maintained for a longer period of time.

The SMT LEDs, as shown, shine upwards with respect to the PCB. Thus, the light-catchers 67 have to be angled downwards in order to receive the light. In some installations, it is preferred to use side-shining SMT LEDs, whereby the light-strips do not have to be wrapped over the edge of the frame. Side-shining LEDs are generally more costly than top-shining, but the light-strips are simplified.

Upon assembly of the key-pad unit 20 to the PCB 21, dowels 74 underneath the rails 25 of the frame 23 engage corresponding holes 76 in the PCB 21, for location purposes. Apart from that, no other physical or electrical or light-transmitting connections are required between the key-pad unit 20 and the PCB 21.

The frame 23 is of rigid plastic, and preferably is black in colour for light-shielding effect. The rails 25 that run widthwise across the PDA preferably, as shown, can be surmounted by rulers or dividers 78, which lie between adjacent rows of keys. It will be understood that dividing the rows of keys by a non-depressible ruler can be of considerable advantage to the user or operator of the PDA key-pad. The rulers 78 lie between, and serve to separate, the light-strips 41. The rulers 78 may be chrome-plated, or decorated with NCVI (non-conductive vapour metallization).

The "feel" of the key, when it is pressed, is important. The under-block 47 and the rectangle of the button-receiving socket 45 serve to stiffen the flexible light-strip 41 in the region of the key, for a good key feel. Also, the actuator 56 between the key-cap 29 and the key-switch 58 is important as regards the feel of the key. Because the actuator 56 is a thick mass, but is made of soft flexible material, the key feels firm enough, but yet there is no discernible bottoming of the key. Bottoming has a bad feel, and also can permit damage e.g to the PCB key-switch caused by overpushing.

To improve the feel of the keys, also the key-switches 58 preferably are slightly pre-loaded by the respective actuators 56, e.g by up to 0.15 mm of interference. Interference is preferred over a gap between the actuator and the key-switch, not only because lost travel would have a bad feel, but to supplement the firmness with which the key is held in its nominal position, when not depressed.

Co-molding the light-strips with the sockets and blocks permits or enables a combination of material properties. The light-strips, being attached between the key-caps and the actuators, need to be flexible enough to travel downwards, with the keys, when the keys are depressed. The light-strips 41 should also be flexible enough that when one of the keys is depressed, the keys adjacent to it in the row are not dragged down with it.

Terms of orientation, such as "above", "down", "left", and the like, when used herein are intended to be construed as follows. When the terms are applied to an apparatus, the apparatus is distinguished by the terms only if there is not one single orientation into which the apparatus (or an image of the apparatus) can be placed, in which

the terms can be applied consistently.

The numerals used in the drawings may be collated as:-

20	key-pad unit
21	circuit-board PCB
23	rigid plastic frame
25	rail
27	space or pocket
29	key-cap
30	under-button
32	visible outer surface
34	mask or coating
36	window
38	under-surface of under-button 30
41	light-strip
43	overface of light-strip 41
45	button-receiving socket
47	under-block
49	underface of light-strip 41
50	block-receiving socket
52	resilient membrane, diaphragm, or web
54	ledge
56	actuator
58	PCB key-switch
61	linking strap
63	notch
65	tenon
67	light-catcher
69	under-face of light-catcher 67
70	light-emitting diode LED
72	light-shielding sheet
74	dowel
76	dowel-hole

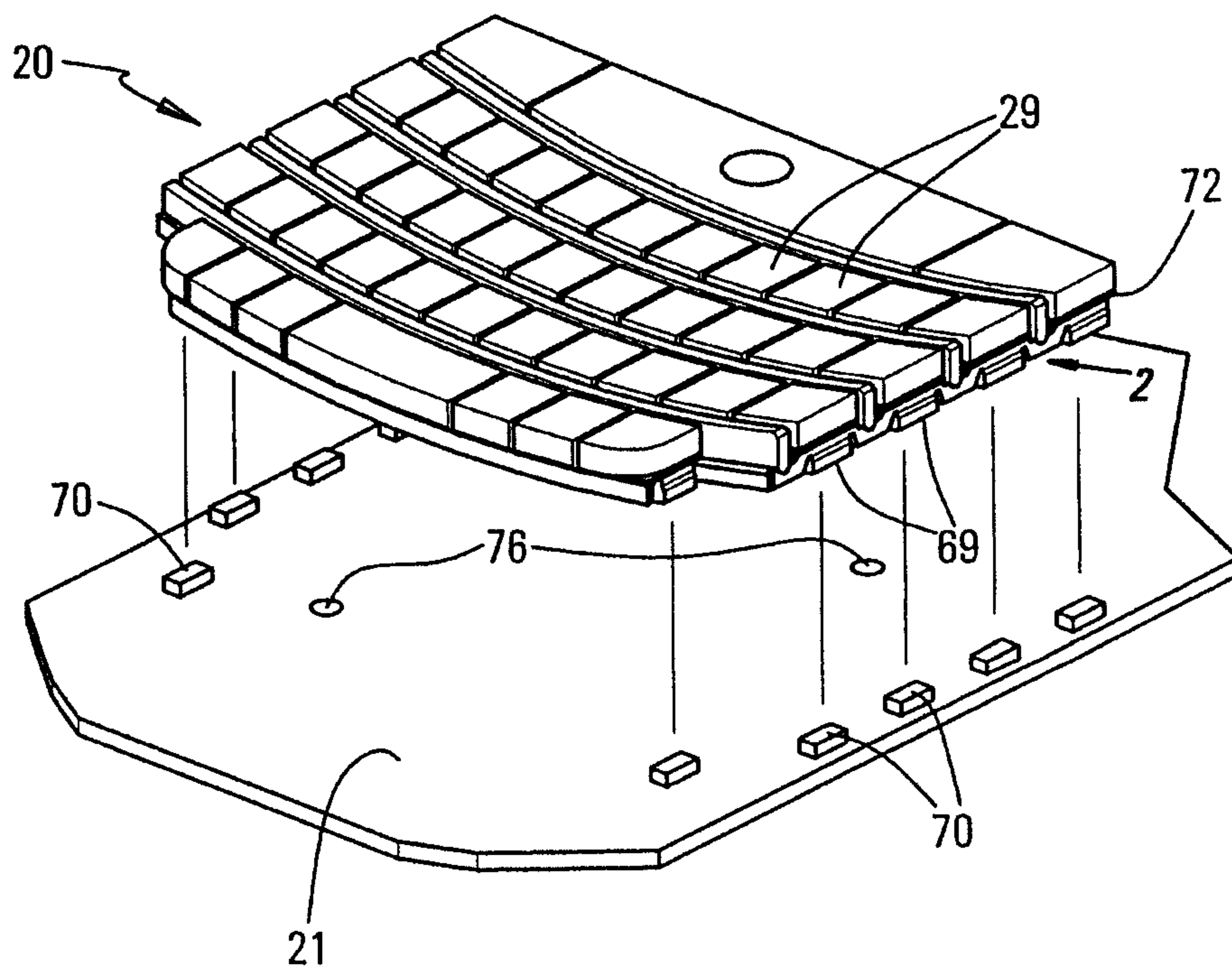
78 ruler

The above-described embodiments of the invention are intended to be examples only. Alterations, modifications and variations can be effected to the particular embodiments by those of skill in the art without departing from the scope of the invention, which is defined solely by the claims appended hereto.

## Claims:

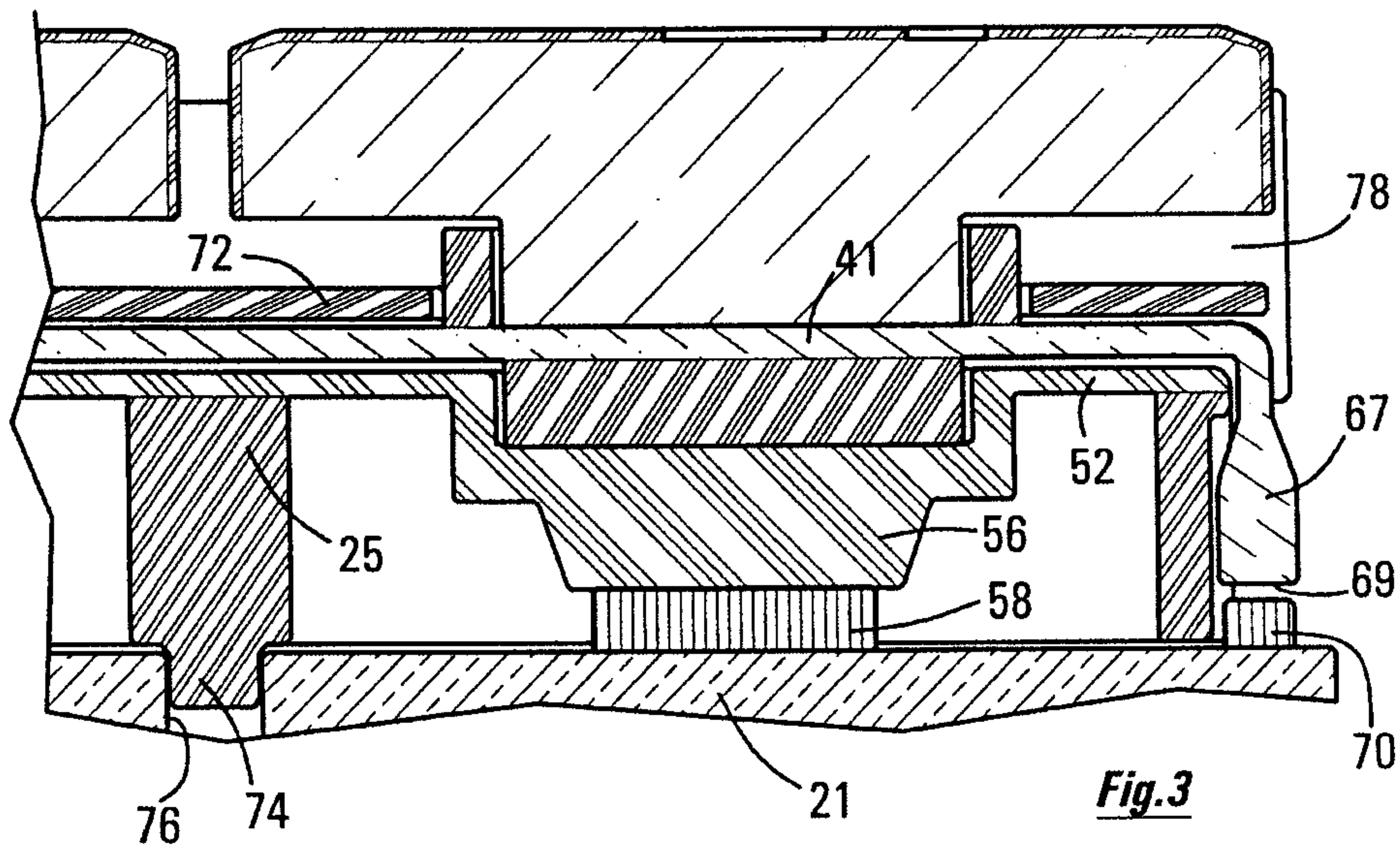
1. An illuminated key-pad unit comprising:  
a set of depressible keys, the keys including respective key-caps;  
a flexible web structure including block sockets; and  
at least one light strip including under-blocks to engage the block sockets and a set of key-cap sockets, located on a top surface of the light strip, to engage the key caps.
2. The key-pad unit of Claim 1 wherein the at least one light strip is of transparent or translucent light transmitting material.
3. The key-pad unit of Claim 1 or claim 2 wherein the at least one light strip radiates light from an overface of the light strip.
4. The key-pad unit of Claim 3 wherein the overface is in direct contact with an under surface of each key cap.
5. The key-pad unit according to any one of claims 1 to 4 wherein the at least one light strip is flexible.
6. The key-pad unit according to any one of claims 1 to 5 wherein the keys are arranged in a plurality of rows of keys, each row of keys having a corresponding light strip, the corresponding light strips connected via respective linking strips.
7. The key-pad unit of Claim 6 wherein the linking strips are formed with notches which are hooked under tenons formed in a base frame of the unit.
8. The key-pad unit according to any one of claims 1 to 7 wherein the at least one light strip comprises light catchers at each end thereof.

- 9 The key-pad unit according to any one of claims 1 to 8 wherein each of the respective key-caps comprises an over-surface having a window displaying a key-identification marking.
10. The key-pad unit according to any one of claims 1 to 9 wherein each key-cap is urged by the web structure into a respective rest position whereby each key-cap can be depressed against the web structure.
11. The key-pad unit according to any one of claims 1 to 10, wherein:  
each key-cap is provided with a respective under-button; and  
the at least one light strip includes a set of button-receiving sockets adapted to engage the respective under-buttons; such that each button-receiving socket is arranged to position the respective under-button laterally and rotationally with respect to each light strip.
12. The key-pad unit of Claim 11 wherein each of the set of button-receiving sockets is physically secured to an overface of the respective light strip.
13. The key-pad unit of Claim 11 or claim 12 wherein each button-receiving socket comprises walls of opaque material to reflect light back into the respective under-button of each key-cap.
14. The key-pad unit according to any one of claims 1 to 13, wherein the under-blocks are co-molded with the material of the light strip.
15. The key-pad unit according to any one of claims 1 to 14, further comprising a frame configured as a grid wherein the frame includes rails that define pockets respective to the key-caps, the pockets being provided between the rails.

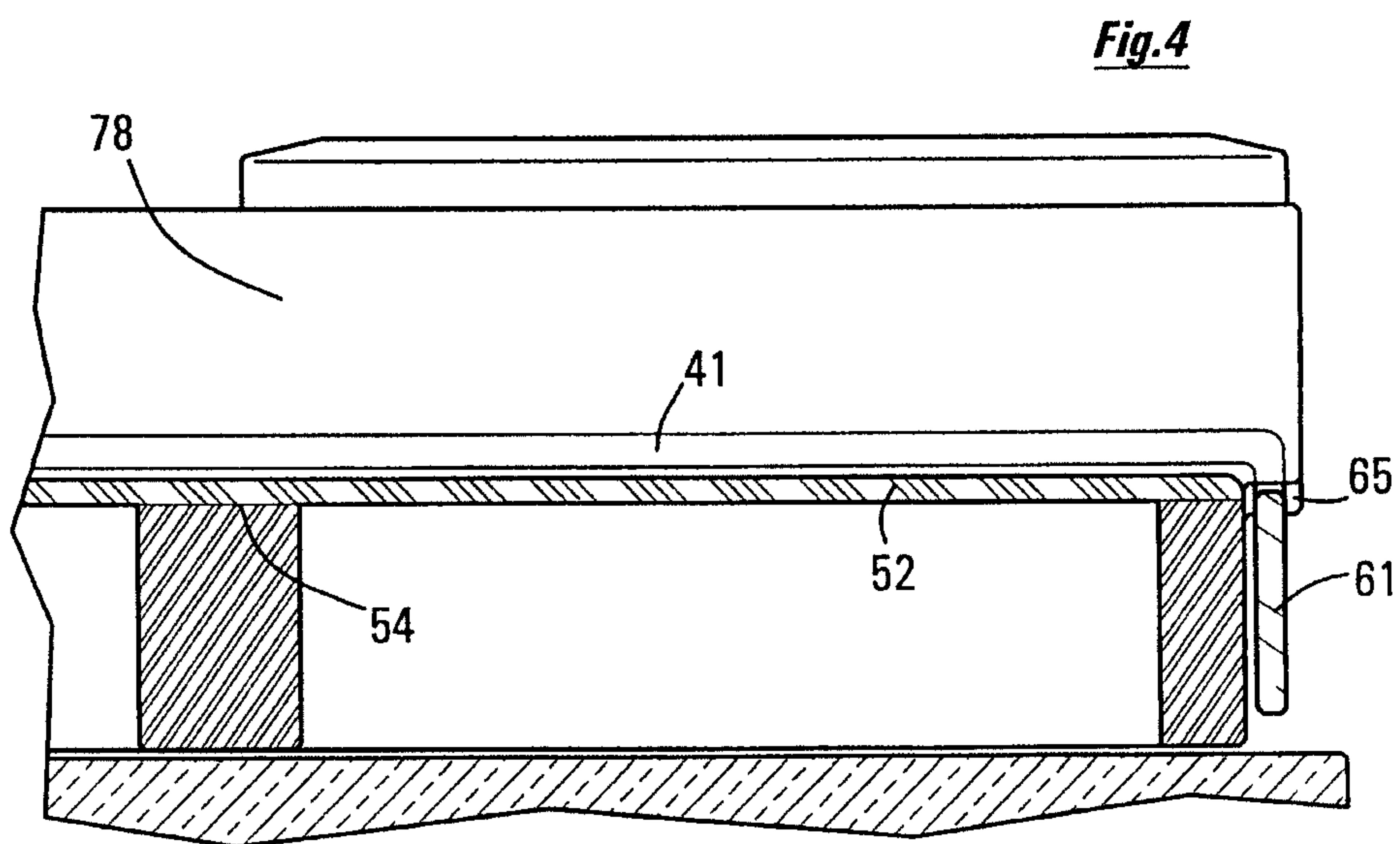


***Fig. 1***





**Fig.3**



**Fig.4**

