

F. LJUNGSTRÖM.
 LABYRINTH PACKING FOR TURBINES.
 APPLICATION FILED MAR. 20, 1911.

997,629.

Patented July 11, 1911.

2 SHEETS—SHEET 1.

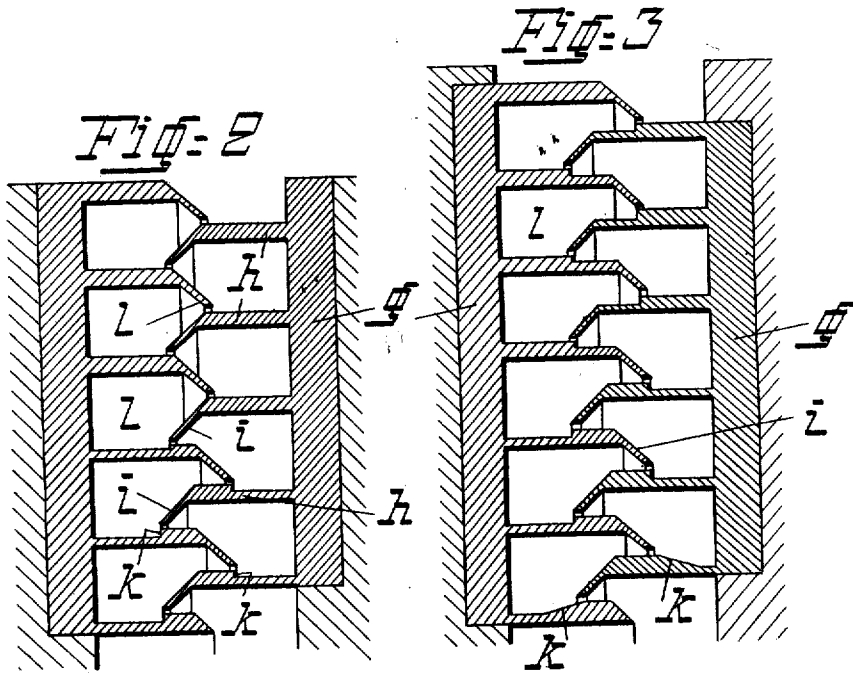
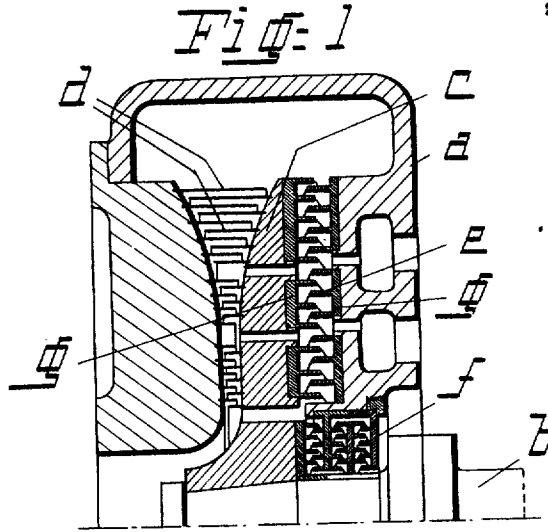

WITNESSES:
G. E. Babcock
G. M. Cooper

INVENTOR
Fredrik Ljungström
 BY *G. E. Babcock*
 ATTORNEY.

F. LJUNGSTRÖM.
LABYRINTH PACKING FOR TURBINES.
APPLICATION FILED MAR. 20, 1911.

997,629.

Patented July 11, 1911

2 SHEETS—SHEET 2.

Fig. 4

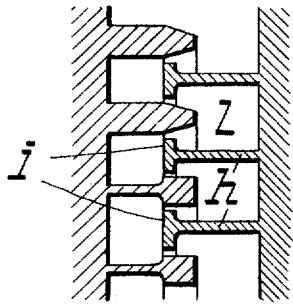

Fig. 5

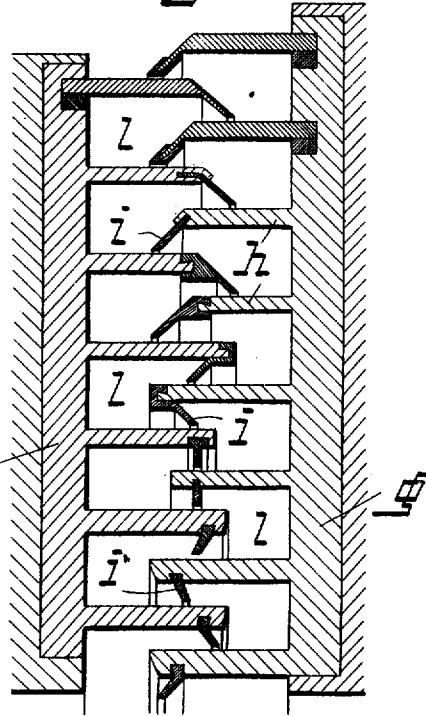
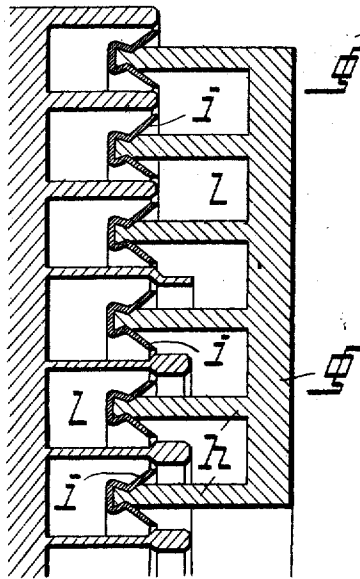

Fig. 6



WITNESSES:

P. E. Babcock
J. M. Cooperbauer

INVENTOR

Fredrik Ljungström

BY

W. H. Babcock

ATTORNEY.

UNITED STATES PATENT OFFICE.

FREDRIK LJUNGSTRÖM, OF LILJEHOLMEN, STOCKHOLM, SWEDEN, ASSIGNOR TO
AKTIEBOLAGET LJUNGSTRÖMS ÅNGTURBIN, OF STOCKHOLM, SWEDEN.

LABYRINTH-PACKING FOR TURBINES.

997,629.

Specification of Letters Patent. Patented July 11, 1911.

Application filed March 20, 1911. Serial No. 615,465.

To all whom it may concern:

Be it known that I, FREDRIK LJUNGSTRÖM, engineer, a subject of the King of Sweden, residing at Liljeholmen, Stockholm, in the
5 Kingdom of Sweden, have invented certain new and useful Improvements in Labyrinth-Packings for Steam or Gas Turbines; and I do hereby declare the following to be a full, clear, and exact description of the invention, such as will enable others skilled in the art to which it appertains to make and use the same.

This invention relates to labyrinth packings, composed of a series of rings and arranged alternately on two parts of the mechanism and fitting into each other to pack the space between such parts. It is desirable to make the play of the rings very slight for lessening leakage, yet they must
10 be guarded against injury from each other during the running of the machine. To this end I make the rings very thin and supply them or some of them with flanges or projecting parts extending toward the proximate rings. These flanges may be integral with the rings or attached thereto
25 and of the same or softer metal. Also they may extend obliquely so that they will readily bend under pressure, this action being facilitated by the heating and softening of the thin metal under compression. Thus the rings will yield without injury.

In the accompanying drawings: Figure 1 represents a vertical longitudinal section of a turbine provided with packing embodying
35 my invention; and Figs. 2, 3, 4, 5 and 6 represent in similar section on an enlarged scale detail views of several different modifications of the packing. In Figs. 2, 3 and
40 the projecting parts are integral with the rings; but in Figs. 5 and 6 they are distinct pieces attached thereto.

a designates the turbine casing, *b* the turbine disk, *c* the rotating disk and *d* the
45 vanes.

e indicates a labyrinth packing arranged between the disk *c* and the turbine casing *a*, and *f* indicates a shaft packing arranged around the shaft. The packing is shown on
50 a larger scale in Fig. 2, in which *g* designates the annular disks carrying the packing rings *h*. The annular disks *g* are alternately secured to the parts, between which the packing is to take place. The packing
55 rings *h* are provided with thin, obliquely

projecting edges *i* ending in close proximity to the adjacent ring. If the parts *i* and the adjacent annular parts should come into contact with each other, no damage will thereby be done to the packing, the parts *i* thereby yielding a little on account of their small dimensions and oblique position, said yielding being facilitated by the ring being heated on account of the friction.

The packing shown in Fig. 2 is especially adapted for selfbalancing purposes, the rings *h* being shaped in such a way that the edges of the parts *i* cooperate with the corresponding edges *k* of the adjacent rings. Fig. 2 shows a central position. When the annular disks *g* are moved against each other in the vane rows, the passages in the lower packings will be increased, while the passages of the upper ones will not be altered by this movement. By this, a greater quantity of high-pressure steam immediately flows into the lower interspaces *l* between the rings, a greater pressure arising between the annular disks *g*, which will cause a pressing apart of these disks, by which a diminishing of the passages between the lower rings again will take place. If the disks should move beyond the central position, the upper interspaces will be opened, so that the pressure falls, and the disks will again occupy their central position.

For the purpose of enabling an introduction of the driving medium into the outer vane rows at an overloading of the turbine, the whole labyrinth packing *e* is divided into several groups, each one acting as a selfbalancing packing independently of the other ones.

Fig. 3 shows a modification which only differs from that one shown in Fig. 2 by all the rings *h* being undercut. When the annular disks *g* have been pressed apart out of their central position, the upper packing interspaces will be greater, the lower ones, however, remaining unchanged. The overpressure in the interspaces *l* pressing apart the disks *g* will soon cease owing to the easier outflow at the outer edge and the disks *g* will again be brought against each other on account of the steam pressure in the vane rows *d*, said disks thereby occupying such a position that the pressure will be the same on both sides of the rotating disk. If thereby the disk should be brought beyond

the central position, the inner packings finally expand, whereas the outer ones remain unchanged, so that a greater pressure will arise in the interspaces l , said pressure causing a pressing apart of the disks. The opposing surfaces of the parts i and the adjacent rings may be oblique so that their contact and the pressure upon them will tend to move the disks out of engagement with each other.

Fig. 4 shows a modification in which the rings only on the one disk are provided with axial projections i on both sides. The rings not having any lateral projections may thereby be made in the manner shown in Fig. 3.

Fig. 5 shows several modifications of the parts i , not integral with the rings h . Said parts can thereby either be made so thin that no danger of the packing being damaged will arise, or they may be made of softer metal than the rings.

Fig. 6 shows a modification especially adapted when the packing is made according to Fig. 4, only every other ring being provided with projections, said projections, however, consisting of special parts distinct from the rings. It is obvious that this packing may be constructed as a selfbalancing packing in a similar way as the packing in Figs. 2 or 3.

It is evident that very large spaces l between the rings will be obtained by means of the present invention, which is important seeing that the leaking steam on flowing out

is subjected to comparatively great changes of speed, and a considerable amount of space is necessary to receive and equalize these varying discharges without injury to the packing or turbine or irregularity of escape. Besides, the annular disks g may be pulled apart in the direction of the axis of the turbine, the assembling and taking apart of the packing being consequently very simple.

Claims:

1. Labyrinth packing, consisting of rings attached alternately to two parts of the mechanism and fitting into each other, the said rings being provided with flexible projecting parts which extend toward the bodies of the proximate rings.

2. Labyrinth packing consisting of rings attached alternately to two parts of the mechanism and fitting into each other, the said rings being provided with thin flanges which project obliquely toward the proximate rings.

3. Labyrinth packing consisting of rings attached alternately to two parts of the mechanism and fitting into each other, each alternate ring being provided on both sides with projections or flanges extending toward the proximate rings.

In testimony whereof, I have signed my name to this specification in the presence of two subscribing witnesses.

FREDRIK LJUNGSTRÖM.

Witnesses:

HEDING MELINDER,
HARRY AEBIHN.