

W. KOCH.
Paper-Perforating Machine.

No. 213,908.

Patented April 1, 1879.

Fig. 2.

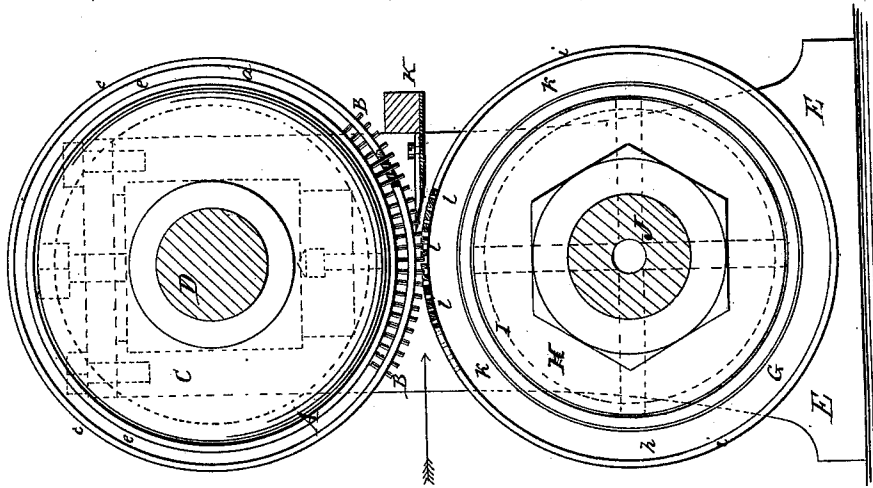

Fig. 1.

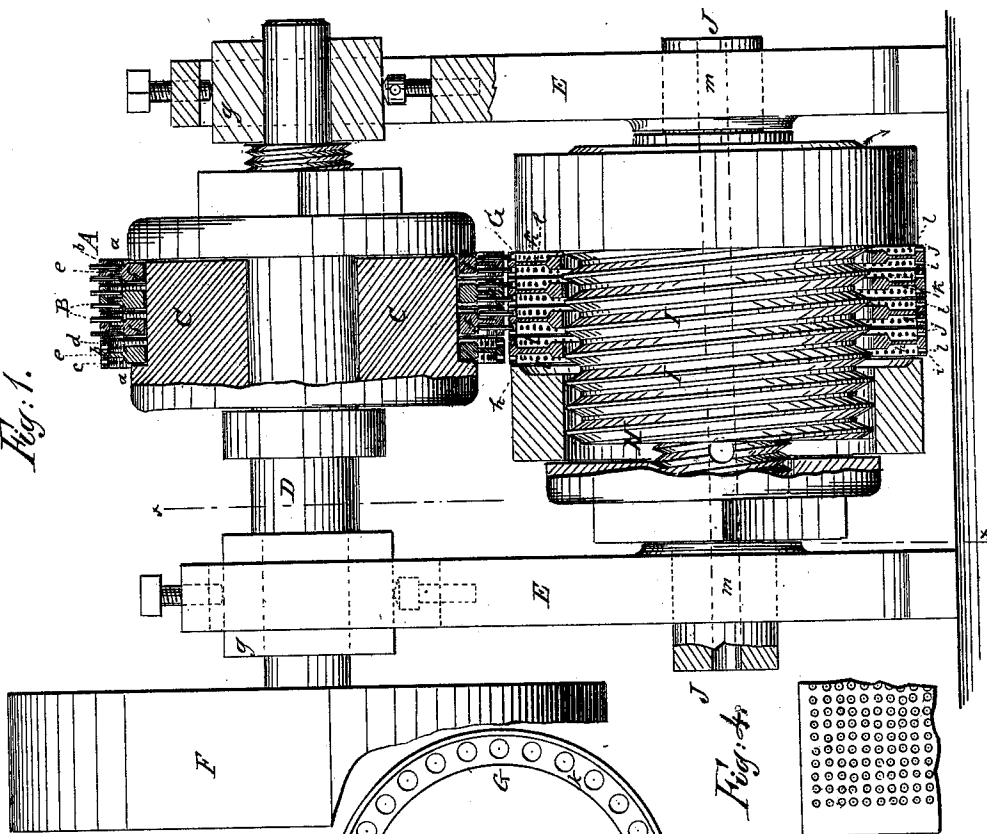

Fig. 4.

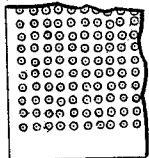
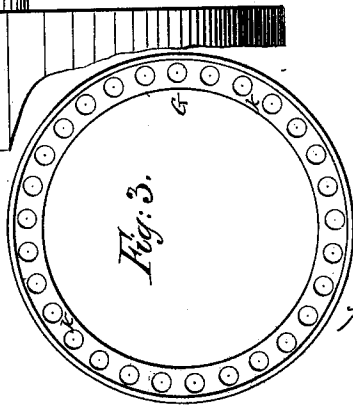

Fig. 3.



Witnesses:
Enas. Nista
A. D. Wattenberg

Inventor:
William Koch
per *G. M. Symington*
Atty

UNITED STATES PATENT OFFICE.

WILLIAM KOCH, OF NEW YORK, N. Y.

IMPROVEMENT IN PAPER-PERFORATING MACHINES.

Specification forming part of Letters Patent No. **213,908**, dated April 1, 1879; application filed December 3, 1878.

To all whom it may concern:

Be it known that I, WILLIAM KOCH, of the city, county, and State of New York, have invented a new and Improved Machine for Perforating Card-Board, &c.; and that the following is a full, clear, and exact description of the same, reference being had to the accompanying drawings, and to the letters of reference marked thereon, making part of this specification.

This invention is in the nature of an improved machine for perforating card-board, &c.; and the invention consists in a machine for perforating card-board, &c., constructed with one or more rings placed on a revolving shaft, and having a double series of punches radially fixed thereto, with a given space between each series, the rings having recesses on their faces or sides, whereby the punches may be outwardly detached from the rings, in combination with a double series of perforations arranged to receive the punches, and with a given space between each series of perforations formed in one or more rings, with recesses in their sides, and secured to a revolving shaft, substantially as hereinafter described.

The invention also consists in a series of perforated rings, with concentric recesses on their sides, in combination with, and secured to, a central core provided with a spiral channel, all constructed and operated in the manner and for the purpose hereinafter described.

In the accompanying sheet of drawings, Figure 1 is a front view of my machine, partly in section; Fig. 2, a cross-section through line *xx*, Fig. 1; Fig. 3, a modification, showing one method of removing the chips; and Fig. 4, a piece of perforated card-board.

Similar letters of reference indicate like parts in the several figures.

As before stated, this invention relates to a machine for perforating card-board, for embroidery, and for perforating stamps, tickets, checks, &c., that they may be readily detached one from another, and for all the purposes for which perforated card-board may be employed.

To this end I construct a series of retaining or confining rings, A, of steel or other suitable material. These rings are formed with concentric recesses *a* turned in their sides or

faces, so that the edge *b* of the ring consists, substantially, of a flange, *c* and *d*, projecting on either side of a central web, *e*, the recesses *a* forming these flanges, and also forming, substantially, a flange or collar, *f*, which surrounds the central opening of the rings. Through the flanges *c* and *d*, and with great accuracy, and extending entirely around the rings A, are drilled a series of holes radially from the true center of the rings. Inserted and firmly fixed within these holes, in the flanges of the rings, are steel punches B, so that each flange is encircled by these punches, each ring having a double series of punches encircling it, and each series of the punches being separated by the web *e*.

The width of the flanges *c* and *d* is such that when a number of these rings, provided with punches, are secured to their shaft, and in close contact with each other, the faces of the contiguous flanges will leave a space equal to the edge of the web *e* between the encircling rows of punches in each flange of each ring A, by which arrangement each encircling row of punches is separated from the other encircling row of punches an equal distance. This space between the punches, as is obvious, regulates the space between the perforations on the card-board.

A series of rings, in this way constructed and provided with punches, are secured side by side on a central hub, C, to which they are clamped in any desirable manner, the hub in turn being fixed to a revolving shaft, D, suitably supported in bearings *g* in uprights E of the machine.

The shaft D is provided at one end with a driving-pulley, F.

Immediately below the rings A and punches B, fixed to a rotating shaft, which is parallel to and in the same plane with the hub C of the rings A, is a series of rings, G, constructed precisely as are the rings A, with recesses *h* in their sides, flanges *i* and *j* on each side of a web, *k*, and with perforations *l* formed in the flanges, so that each ring G is a counterpart of the rings A, excepting that it is not provided with punches, but with perforations only, and excepting, also, that each of the rings A is of slightly less diameter than are the rings G. This difference of diameter between the two se-

ries of rings, however, is accurately made up by the extent to which the punches B project beyond the edge of the rings A, so that as the entire series of rings A and G revolve, the punches B of the rings A will exactly fit into the perforations *l* in the rings G; or, in other words, they will "register" accurately. The rings G are placed side by side in the same manner as are the rings A, before described, and they are secured to a central hub, H, this hub H having formed in its surface a spiral groove, I. Onto the hub H is clamped a series of the rings G side by side, the hub H being secured to a revolving central shaft, J, which axis is supported in suitable bearings *m* in the uprights E. Fixed to the edge of the uprights E is a guide-table or tongue, K.

Now, my device for perforating card-board, &c., constructed substantially as I have described it, is operated as follows: Power of any suitable kind being applied to the driving-pulley F, the hub C is caused to revolve, carrying with it in its revolution the rings A, and as the rings revolve the punches B therein enter into or register with the perforations *l* in the lower rings, G, thereby causing these last-named rings to revolve with their shaft J in substantially the same manner as gear-wheels impart motion one to the other, each of the series of rings in this way revolving simultaneously with each other, but in opposite directions. The card-board, &c., to be perforated is fed between the rings as they revolve, and the punches B perforate the paper by cutting it out and forming holes therein as they descend through the paper into the perforations *l* in the lower series of rings, G; and as the rings revolve, and the paper in this way punched it is drawn or fed between the rings automatically, the entire series of rings A and the entire series of rings G, when secured on their respective shafts, forming substantially two revolving cylinders, operating as before described, and the cylinders in this way formed may be of any desirable length, as circumstances may require.

As each perforation is made through the paper the small disks that are removed by the action of the punches are retained in the perforations *l* of the rings G until, by their accumulation within these perforations, the punches B force them out at the lower ends of the perforations *l*, from whence they fall into the spiral groove I formed in the hub H; and as this hub revolves with the rings and its shaft these little disks or chips are compelled to follow the direction of the spiral, and by it they are led out at one end of the spiral and fall from the machine, as shown in Fig. 1.

The operation of this depositing of the chips from the perforations *l* is facilitated by the recesses *h* in the rings G, which permit the chips to descend substantially without obstruction into the spiral groove I of the hub, the recesses in each contiguous ring forming a space for that purpose.

Instead of permitting the chips to follow the spiral I in the hub H as it revolves, a blower may be attached, so as to send a blast of air through the shaft J, which may be made tubular for that purpose; or in some other way the air may be forced beneath the rings G, and blow these chips from beneath the rings and away from the machine, and the bearings within which the shaft C is received and revolves may be vertically adjusted, whereby the punches may enter to a greater or less extent through the perforations *l* of the rings G, this adjustment depending upon the thickness of the card-board or paper to be perforated.

By this construction of my perforating-machine, and the manner of securing the punches therein, it will be seen that, should from any cause one of the punches become broken or disarranged, it can be removed at once without disturbing the other punches and a new one replaced.

Instead of permitting the chips to be deposited on the spiral I in the hub H, as herebefore described, a series of holes may be drilled in the face of the rings through the web *k*, and a blast of air sent through the lower cylinder and through the holes, and in that way blow out the chips. This modification is shown in Fig. 3.

As the paper, card-board, &c., passes between the rolls, it also passes beneath the table or tongue K, which strips it from the punches and prevents its winding around the rings A.

For large-sized machines gear-wheels may be fixed to the axes of the rolls as a means of driving them, and in this way relieve the punches from the strain.

Having now described my invention, what I claim as new, and desire to secure by Letters Patent, is—

1. In a machine for perforating card-board, &c., one or more rings into which are fixed radially a double series of punches, with a given space between each series, the rings having recesses *a* on their faces, whereby the punches may be outwardly detached from the rings without removing the rings from their shaft, substantially as and for the purpose described.

2. In a machine for perforating card-board, &c., a series of perforated rings fixed to a hub, with a spiral formed therein, whereby the punchings from the card-board, &c., may be carried from the machine, substantially as described.

3. In a machine for perforating card-board, &c., one or more rings with perforations in the peripheries thereof, fixed to a hollow hub, with a spiral groove formed therein, said hub provided with a communicating passage connecting the spiral groove with the interior of the hub, whereby a blast of air may be admitted, for the purpose of facilitating the discharge of the chips from the machine, substantially as described.

4. In a machine for perforating card-board,

&c., one or more rings with recesses *a* formed in their faces, whereby the punches may be detached from the rings without removing the rings from the shaft, and the rings having flanges in their edges, into which flanges are secured the punches, substantially as and for the purpose described.

5. In a machine for perforating card-board, &c., one or more rings with a double series of perforations in their peripheries, and with a

given space between each of the series, and with recesses formed in their sides, in combination with a shaft with spiral groove formed therein, whereby the passage of the chips from the machine is facilitated, substantially as described.

WILLIAM KOCH.

Witnesses:

H. L. WATTENBERG,
G. M. PLYMPTON.