

(19) AUSTRALIAN PATENT OFFICE

(54) Title
Air decontamination device and method

(51)⁶ International Patent Classification(s)
B01D 53/32 (2006.01) 9/20
A61L 9/015 (2006.01) 20060101ALI2006072
A61L 9/20 (2006.01) ^{2BMEP} **A61L**
A61L 9/22 (2006.01) 9/22
B01D 53/66 (2006.01) 20060101ALI2006072
B01D 53/86 (2006.01) ^{2BMEP} **B01D**
B01D 53/32 53/66
20060101AFI2006072 20060101ALI2006072
^{2BMEP} **A61L** ^{2BMEP} **B01D**
9/015 53/86
20060101ALI2006072 20060101ALI2006072
^{2BMEP} **A61L** ^{2BMEP}
PCT/GB2005/002531

(21) Application No: 2005259000 (22) Application Date: 2005 .06 .29

(87) WIPO No: W006/003382

(30) Priority Data

(31) Number	(32) Date	(33) Country
0414602.3	2004 .06 .30	GB

(43) Publication Date : 2006 .01 .12

(71) Applicant(s)
Tri-Air Developments Limited

(72) Inventor(s)
Mole, Alan

(74) Agent/Attorney
Intellepro, Level 7 102 Adelaide Street, Brisbane, QLD, 4000

(56) Related Art
WO 2000/074820 A1
US 2004140194 A1
EP 529937 A
JP 11-221489 A
JP 2000 237529 A
EP 1175916 A
US 2002153241 A1
US 2005129591 A1
US 20030192562 A1

(19) World Intellectual Property Organization
International Bureau



(43) International Publication Date
12 January 2006 (12.01.2006)

PCT

(10) International Publication Number
WO 2006/003382 A1

(51) International Patent Classification: **B01D 53/32**,
53/66, 53/86, A61L 9/22

(21) International Application Number:
PCT/GB2005/002531

(22) International Filing Date: 29 June 2005 (29.06.2005)

(25) Filing Language: English

(26) Publication Language: English

(30) Priority Data:
0414602.3 30 June 2004 (30.06.2004) GB

(71) Applicant and
(72) Inventor: **MOLE, Alan** [GB/GB]; Laburnum Cottage,
Station Road, Eckington, Pershore, Worcestershire WR10
3BB (GB).

(74) Agent: **MARKS & CLERK**; 27 Imperial Square, Chel-
tenham, Gloucestershire GL50 1RQ (GB).

(81) Designated States (unless otherwise indicated, for every
kind of national protection available): AE, AG, AL, AM,

AT, AU, AZ, BA, BB, BG, BR, BW, BY, BZ, CA, CH, CN,
CO, CR, CU, CZ, DE, DK, DM, DZ, EC, EE, EG, ES, FI,
GB, GD, GE, GH, GM, HR, HU, ID, IL, IN, IS, JP, KE,
KG, KM, KP, KR, KZ, LC, LK, LR, LS, LT, LU, LV, MA,
MD, MG, MK, MN, MW, MX, MZ, NA, NG, NI, NO, NZ,
OM, PG, PI, PL, PT, RO, RU, SC, SD, SH, SG, SK, SL,
SM, SY, TJ, TM, TN, TR, TT, TZ, UA, UG, US, UZ, VC,
VN, YU, ZA, ZM, ZW.

(84) Designated States (unless otherwise indicated, for every
kind of regional protection available): ARIPO (BW, GH,
GM, KE, LS, MW, MZ, NA, SD, SL, SZ, TZ, UG, ZM,
ZW), Eurasian (AM, AZ, BY, KG, KZ, MD, RU, TJ, TM),
European (AT, BE, BG, CH, CY, CZ, DE, DK, EE, ES, FI,
FR, GB, GR, HU, IE, IS, IT, LT, LU, MC, NL, PL, PT, RO,
SE, SI, SK, TR), OAPI (BF, BJ, CF, CG, CI, CM, GA, GN,
GQ, GW, ML, MR, NE, SN, TD, TG).

Published:
— with international search report

For two-letter codes and other abbreviations, refer to the "Guid-
ance Notes on Codes and Abbreviations" appearing at the begin-
ning of each regular issue of the PCT Gazette.

(54) Title: AIR DECONTAMINATION DEVICE AND METHOD

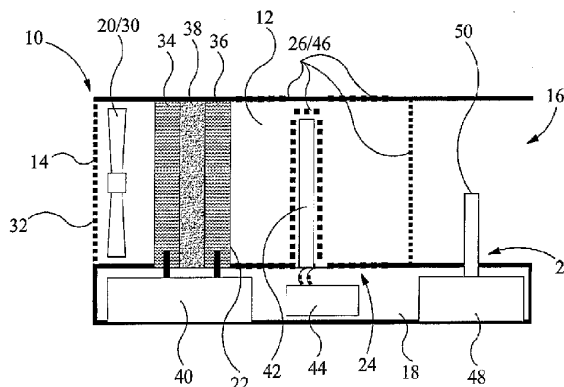

(57) Abstract: An air decontamination device comprises an air stream generator (20), a nonthermal plasma filter (22), an ultraviolet radiation emitting device (24), an ozone catalysing device (26), and a hydrocarbon emitter (28). The air stream generator (20) generates and directs an air stream through or across the non-thermal plasma filter (22), the UV radiation emitting device (24), the ozone catalysing device (26), and the hydrocarbon emitter (28). The plasma filter (22) produces free radicals by which contaminants in the air stream are neutralised. The UV radiation emitting device (24) breaks down ozone in the air stream, catalysed by the ozone catalysing device (26). The hydrocarbon emitter (28) discharges an aromatic hydrocarbon into the air stream to preferentially react with residual ozone so that the air stream becomes suitable for human exposure. A method is also provided.

WO 2006/003382 A1

AIR DECONTAMINATION DEVICE AND METHOD

The present invention relates to a method of decontaminating air, and to a device for use with said method.

5

Air purity and being able to consistently remove contaminants entrained in the air is extremely important, especially in supposedly sterile or hygienic environments, such as hospitals and kitchens. It is also beneficial having decontaminated air in doctors surgeries, and workplace environments making it
10 more difficult for germs and disease to spread.

In addition to microbiological contaminants, chemical gases or vapours can present a serious hazard, either as a by-product of industrial processing or as a malicious attack through terrorism or chemical warfare.

15

The present invention seeks to provide a solution to these problems.

According to a first aspect of the present invention, there is provided a method of decontaminating air using a continual supply of free radicals, the method
20 comprising the steps of:

- (a) First, directing an air stream to be decontaminated through a device including a non-thermal plasma filter whereby free radicals are produced by which contaminants in the air stream are neutralised;

- (b) Second, breaking down ozone in the airstream output from the non-thermal plasma filter by subjecting the airstream to ultraviolet radiation in the presence of a catalyst to increase free radical level; and
- 5 (c) Third, introducing a hydrocarbon having a carbon-carbon double bond into the air stream to preferentially react with the residual ozone initiating a free radical cascade which continues outside of the device.
- 10 Preferable and/or optional features of the first aspect of the invention are set forth in claims 2 to 8, inclusive.

According to a second aspect of the present invention, there is provided a device for decontaminating air using a continual supply of free radicals, the

15 device comprising a housing enclosing:

- a non-thermal plasma filter;
- an ultra-violet radiation-emitting device;
- an ozone catalysing device;
- a hydrocarbon-emitting device; and
- 20 • an airstream generator operable to generate and direct air to pass through or across the non-thermal plasma filter, the ultra-violet radiation-emitting device, the ozone catalysing device and the hydrocarbon-emitting device.

Preferable and/or optional features of the second aspect of the invention are set forth in claims 10 to 21, inclusive.

The present invention will now be more particularly described, by way of example, with reference to the accompanying drawing, which shows a diagrammatic cross-sectional side view of an air decontamination device, in accordance with the second aspect of the invention.

Referring to the drawings, there is shown an air decontamination device which comprises a housing 10 having a flow passage 12, an air inlet 14 to the flow passage 12 and an air outlet 16 exiting from the passage 12, and a compartment 18 adjacent to the flow passage 12. An air stream generator 20, a non-thermal plasma filter 22, an ultraviolet (UV) radiation emitting device 24, an ozone catalysing device 26, and a hydrocarbon emitter 28 are located in the passage 12.

The air stream generator 20 is provided adjacent the air inlet 14 of the passage 12. The air stream generator 20, in this embodiment, is an electric fan 30 powered by mains electricity or battery packs (not shown) provided in the compartment 18 of the housing 10. As a safety measure, a grill 32 is provided across the air inlet 14 to prevent accidental access to the fan 30 while in operation.

The non-thermal plasma filter 22 is positioned adjacent the fan 30, downstream of the air inlet 14. The plasma filter 22 comprises a cathode 34 and anode 36, between which is sandwiched a dielectric 38. The cathode 34 and

anode 36 are powered by a power supply unit (PSU) 40 housed in the compartment 18 of the housing 10.

The cathode 34 and anode 36 comprise reticulated (three dimensionally porous) conductive elements, in this case being aluminium and carbon composite. However, any rigid reticulated conductive or semi-conductive material could be used.

The dielectric 38 is activated alumina pellets, nominally 3 to 4 millimetres in diameter. However, again, the dielectric 38 could be any suitable material to suit varying applications and specific requirements. The dielectric 38 material may be coated with a catalytic material.

The UV radiation emitting device 24 includes an ultraviolet light emitting tube 42 powered by a PSU 44 housed in the compartment 18 of the housing 10.

The UV light emitting tube 42 is disposed in the passage 12, downstream of the non-thermal plasma filter 22, and coincident with the ozone catalysing device 26.

The ozone catalysing device 26 comprises a mesh 46 disposed across the passage 12 and surrounding the UV light emitting tube 42. The mesh 46 includes a coating of ozone catalysing material, such as a mixture of titanium, lead and manganese oxides.

The hydrocarbon emitter 28 includes a rechargeable hydrocarbon reservoir 48 located in the compartment 18 of the housing 10, an evaporator 50 for

evaporating liquid hydrocarbon held in the reservoir 48, and a pump (not shown) by which the gaseous hydrocarbon is discharged into the passage 12. The reservoir 48 contains a liquid aromatic hydrocarbon, for example an olefin such as a Terpene and, more specifically, Myrcene. The outlet 16 of the hydrocarbon emitter 28 is located at or in the vicinity of the centre of the passage 12 of the housing 10, and downstream of the UV light emitting tube 42 and mesh 46 of the ozone catalysing device 26. The outlet 16 of the hydrocarbon emitter 28 is located adjacent the outlet 16 of the passage 12 of the housing 10.

10 Any other suitable means for supplying volatized aromatic hydrocarbon to the outlet 16 of the hydrocarbon emitter 28 can be used.

The air decontamination device can be solely powered by mains electricity, solely powered by battery packs, which may be rechargeable, or may be selectively energisable by both power sources.

15

The air decontamination device can be produced in the form of a portable device, and this can take the dimensions of or substantially of a suitcase. Alternatively, the air decontamination device can be produced as a larger device intended to remain in one location once installed. The latter device is more suitable for, but not limited to, industrial or commercial installations and premises.

In use, the air decontamination device is positioned in the location to be decontaminated. The device is intended to decontaminate air within a building, chamber, enclosure, trunking, pipe, channel or other enclosed or substantially

enclosed area. However, with sufficient through-flow capacity, it can also decontaminate air in an open outside environment.

The device is energised, and the fan 30 generates a stream of ambient air
5 along the passage 12 of the housing 10. The air stream passes initially through the non-thermal plasma filter 22. The filter utilises the characteristics of a non-thermal plasma to 'plasmalise' the constituent parts of the air within the dielectric core. In general terms, the outer ring electrons in the atomic structure of the elements comprising air (principally oxygen and nitrogen) are 'excited' by the intense
10 electronic field generated by the non-thermal plasma, typically being 10Kv at 20KHz. The energised electrons release energy through collisions. However, little or no heat is emitted due to the insubstantial mass of the electrons and the consequent lack of ionisation that occurs. The released energy is sufficient to generate free radicals within the air stream, such as O[·] and OH[·]. The free radicals
15 are powerful oxidants, and will oxidise hydrocarbons, organic gases, and particles typically 2.5 picometres and below, such as bacteria, viruses, spores, yeast moulds and odours. Only the most inert elements or compounds will generally resist oxidation.

20 Since many of the resultants of the oxidative reactions are transient and surface acting, due to having zero vapour pressure, by providing a molecular thick catalytic coating on some or all of the dielectric material of the non-thermal plasma, oxidation of particular molecules or compounds, for example nerve gas agents, within the non-thermal plasma can be targeted.

25

The non-thermal plasma filter 22 produces ozone as one of the by-products. This is entrained in the air stream leaving the non-thermal plasma filter 22. The half-life of ozone is dependent on atmospheric conditions and, itself being a powerful oxidant, under normal circumstances will continue to react in the air long after it has exited the plasma core. This is unacceptable for a device operated by and in the general vicinity of people.

The air stream leaving the non-thermal plasma filter 22 therefore passes to the UV light emitting tube 42 and through the surrounding mesh 46 of the ozone catalysing device 26. The ultraviolet radiation emitted at 253.4 nanometres wavelength by the UV light emitting tube 42 acts to break down the ozone entrained in the air stream leaving the plasma filter 22. The coating on the mesh 46 acts to catalyse this break down.

This destruction (photo-oxidation) of the ozone increases the free radical level, and particularly the level of Hydroxyl radicals OH^\cdot , within the air stream. These free radicals also vigorously oxidise contaminants remaining within the air stream.

Trials have shown that free radicals resident in the air stream post-plasma filtering significantly increase the rate of generation of free radicals during the photo-oxidative process.

It is not possible to destroy all of the ozone entrained in the air stream from the plasma filter 22 using the UV radiation emitting device 24 and ozone catalysing

device 26. Experimentation has shown that an air stream containing 7 parts-per-million (ppm) ozone will still have 10% to 12% of the ozone surviving the process. This potentially results in an ozone concentration in the order of 840 parts-per-billion (ppb), which is around eight times greater than recommended levels for human exposure.

The air stream thus exits the ozone catalysing device 26 and passes along the passage 12 to the hydrocarbon emitter 28. The hydrocarbon emitter 28 discharges volatilised aromatic hydrocarbon into the air stream in order to reduce the remaining residual ozone to acceptable levels. Myrcene is suggested, since it is naturally occurring, has no known toxicity, and is widely used to 'extend' perfumes and fragrances.

Myrcene contains three carbon=carbon double bonds in its molecular structure. Ozone reacts preferentially with Myrcene evaporated into the air stream. When Myrcene reacts with ozone, a 'free radical cascade' is triggered. More than thirty interrelated reactions occur, many of which produce a series of short half life oxidants such as hydro peroxides, super oxides, hydro-oxy peroxides, and hydroxy peroxides. Each of these oxidants breaks down releasing yet further free radicals, which in turn promulgate the production of these oxidative species. This process continues until all the residual ozone is utilised.

The products of these preferential reactions have zero vapour pressure, and hence condense on any remaining particle in the air stream or surface. As a result,

decontamination of contaminants within the ambient air, once the decontaminated air stream exits through the outlet 16 of the housing 10, occurs.

These initiated condensation reactions outside of the decontamination device may cause small particulate 'growing', resulting, in extreme cases, in a visible fog or mist. This is undesirable. However, due to the air decontamination device effectively recirculating and re-decontaminating air within an environment, these small particulates are in any event removed within the non-thermal plasma filter 22.

10

The small particulates are actually beneficial in that they fuel the production of hydroxyl radicals within the plasma filter 22 once recirculated. Thus, although the potential for a visible fog is undesirable, it is beneficial in increasing the efficiency of the decontamination device, and thus the resultant safety of the ambient air.

The air stream generator can be driven in reverse, enabling decontamination of the interior of the device by drawing excess free radicals entrained in the air stream back through the device. As such, the device is largely self-cleaning.

The embodiment described above is given by way of example only, and modifications will be apparent to persons skilled in the art without departing from the scope of the invention as defined by the appended claims. It will also be appreciated that the words "comprise" or "comprising" are used herein in their non-

25

exhaustive sense and the addition of other integers or features to the features claimed is within the scope of the invention claimed.

CLAIMS

1. A method of decontaminating air using a continual supply of free radicals,
the method
5 comprising the steps of:
- (d) First, directing an air stream to be decontaminated through a
device including a non-thermal plasma filter whereby free radicals
are produced by which contaminants in the air stream are
neutralised;
- 10 (e) Second, breaking down ozone in the airstream output from the
non-thermal plasma filter by subjecting the airstream to ultraviolet
radiation in the presence of a catalyst to increase free radical level;
and
- 15 (f) Third, introducing a hydrocarbon having a carbon-carbon double
bond into the air stream to preferentially react with the residual ozone
initiating a free radical cascade which continues outside of the
device.
2. A method as claimed in claim 1, wherein, in step (b), the air stream is
subjected to ultraviolet radiation.
- 20 3. A method as claimed in claim 1 or claim 2, wherein, in step (b), the air
stream is exposed to a catalyst to accelerate the break down of the ozone.
4. A method as claimed in claim 3, wherein the catalyst is a mixture of
titanium, lead, and manganese oxides.

5. A method as claimed in any one of the preceding claims, wherein the said hydrocarbon is an olefin.
6. A method as claimed in claim 5, wherein the olefin is a Terpene.
7. A method as claimed in claim 6, wherein the Terpene is Myrcene.
- 5 8. A method as claimed in any one of the preceding claims, wherein the said hydrocarbon is evaporated into the air stream.
9. A device for decontaminating air using a continual supply of free radicals comprising a housing enclosing:
- a non-thermal plasma filter;
 - 10 • an ultra-violet radiation-emitting device;
 - an ozone catalysing device;
 - a hydrocarbon-emitting device; and
 - an airstream generator operable to generate and direct air to pass through or across the non-thermal plasma filter, the ultra-violet radiation-emitting device, the ozone catalysing device and the hydrocarbon-emitting device.
- 15
10. A device as claimed in claim 9, wherein the non-thermal plasma filter is upstream of the UV radiation emitting device, and the hydrocarbon emitter is downstream of the UV radiation emitting device.
- 20 11. A device as claimed in claim 9 or claim 10, wherein the non-thermal plasma filter is upstream of the ozone catalysing device, and the hydrocarbon emitter is downstream of the ozone catalysing device.
12. A device as claimed in any one of claims 9 to 11, wherein the UV radiation emitting device and the ozone catalysing device are substantially coincident with each other.
- 25

13. A device as claimed in claim 12, wherein the ozone catalysing device surrounds the UV radiation emitting device.
14. A device as claimed in any one of claims 9 to 13, wherein the UV radiation emitting device is an ultraviolet light emitting tube.
- 5 15. A device as claimed in any one of claims 9 to 14, wherein the ozone catalysing device is a mesh coated with ozone catalysing material.
16. A device as claimed in claim 15, wherein the ozone catalysing material is a mixture of titanium, lead, and manganese oxides.
- 10 17. A device as claimed in any one of claims 9 to 16, wherein the hydrocarbon emitter includes a reservoir of hydrocarbon having a carbon-carbon double bond, and means for supplying the said hydrocarbon as a gas to an outlet of the emitter.
18. A device as claimed in any one of claims 9 to 17, wherein the air stream generator is in the form of a fan.
- 15 19. A device as claimed in claim 18, wherein the fan is positioned upstream of the non-thermal plasma filter.
20. A device as claimed in claim 18 or claim 19, wherein the fan is reversible to enable self-decontamination of the device.
21. A device as claimed in any one of claims 9 to 20, wherein the device is portable.
- 20 22. An air decontamination device substantially as described with reference to the accompanying drawings.
23. A method of decontaminating air substantially as described.

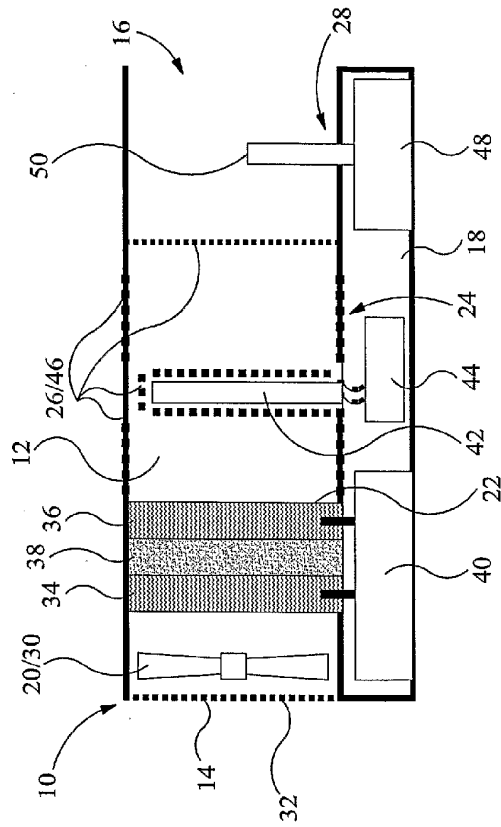

FIGURE 1