

Aug. 20, 1935.

H. ANDERSON

2,011,839

FEEDING MECHANISM

Filed July 5, 1933

8 Sheets-Sheet 1

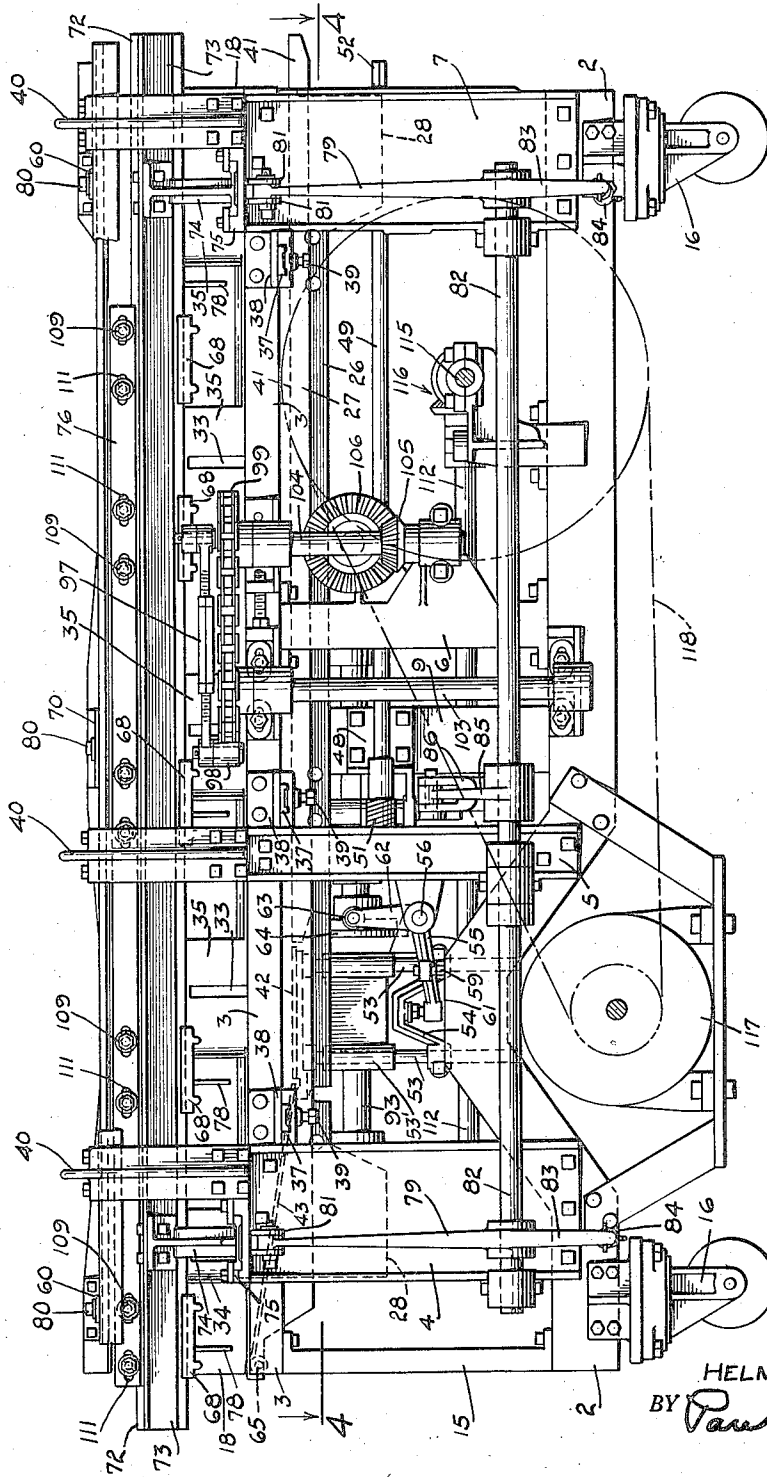

Fig. 1

INVENTOR.  
HELMER ANDERSON  
BY *Paul Paul Moore*  
ATTORNEYS.



Aug. 20, 1935.

H. ANDERSON

2,011,839

FEEDING MECHANISM

Filed July 5, 1933

8 Sheets-Sheet 3

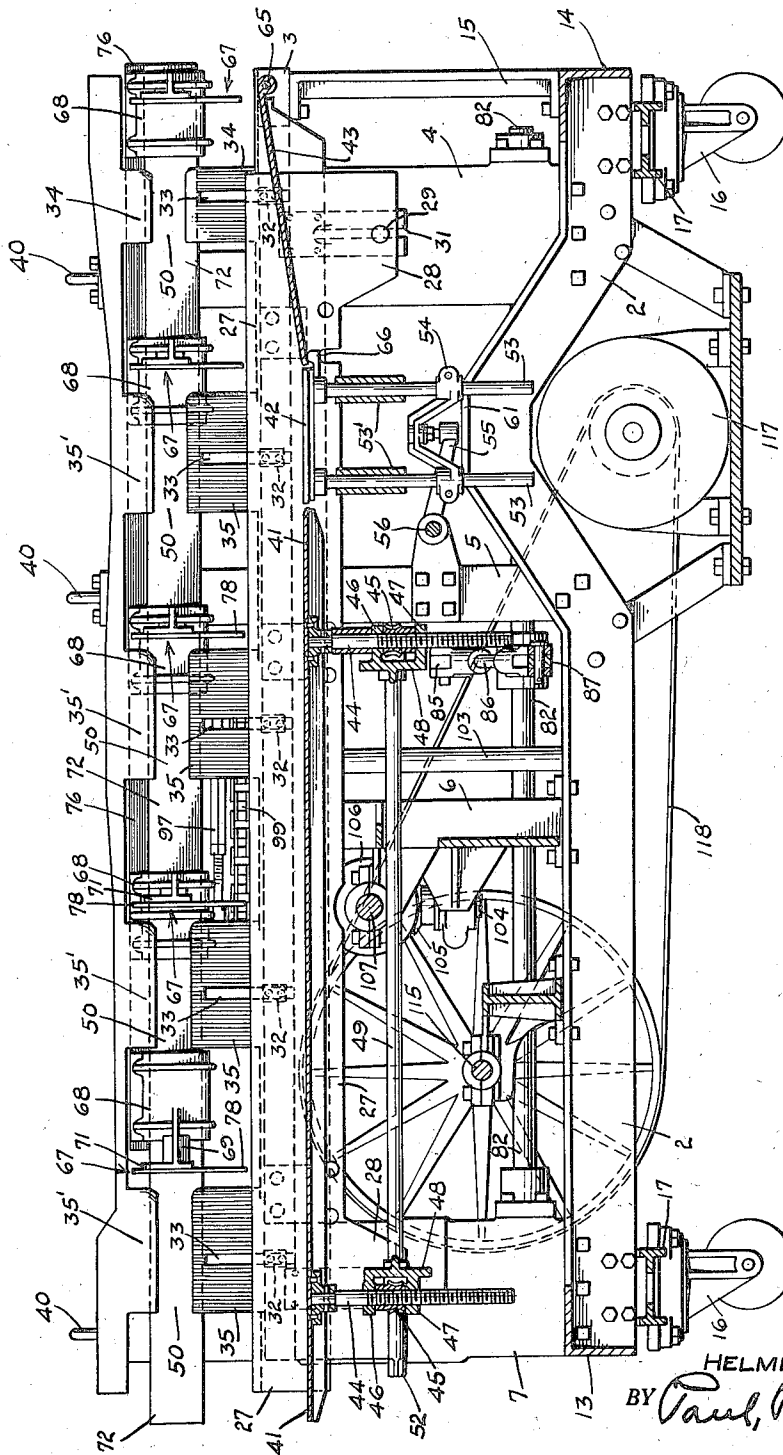

Fig. 3

INVENTOR.  
HELMER ANDERSON  
BY *Paul, Paul Moore*  
ATTORNEYS.

Aug. 20, 1935.

H. ANDERSON

2,011,839

FEEDING MECHANISM

Filed July 5, 1933

8 Sheets-Sheet 4

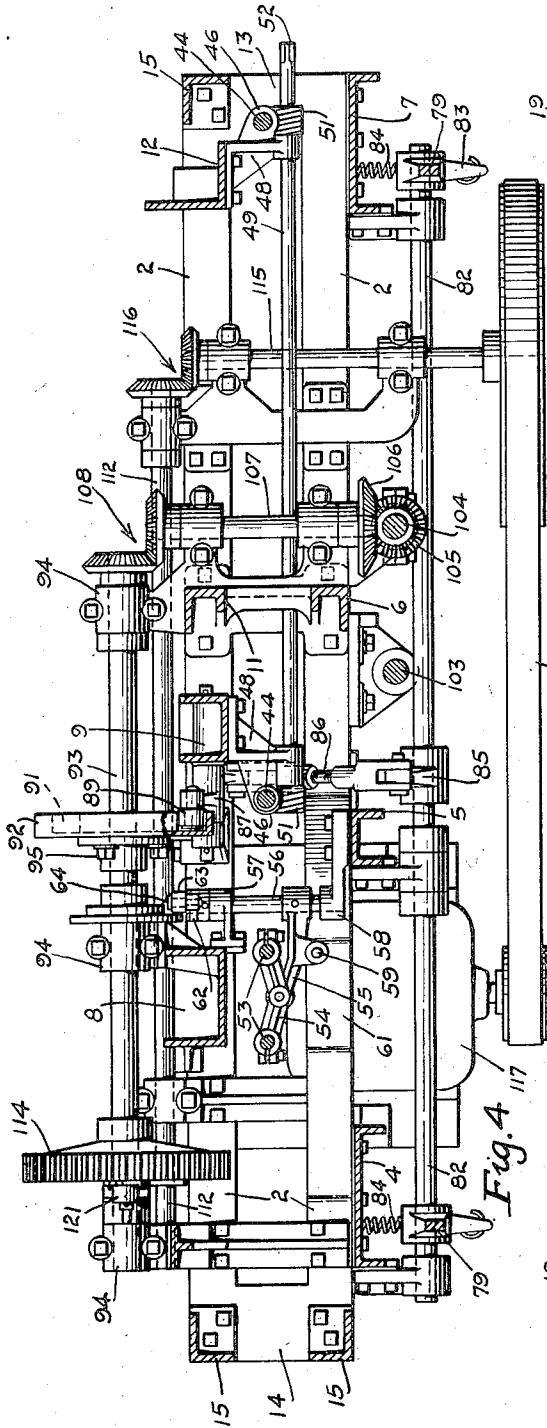

Fig. 4

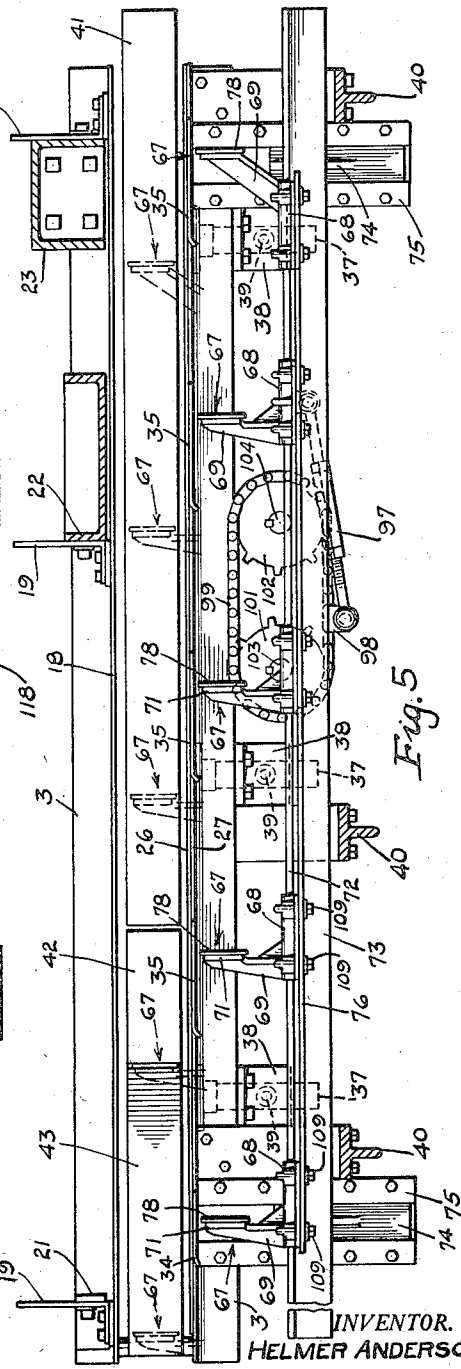

Fig. 5

INVENTOR.  
HELMER ANDERSON

BY *Paul, Paul Moore*  
ATTORNEYS.

Aug. 20, 1935.

H. ANDERSON

2,011,839

FEEDING MECHANISM

Filed July 5, 1933

8 Sheets—Sheet 5

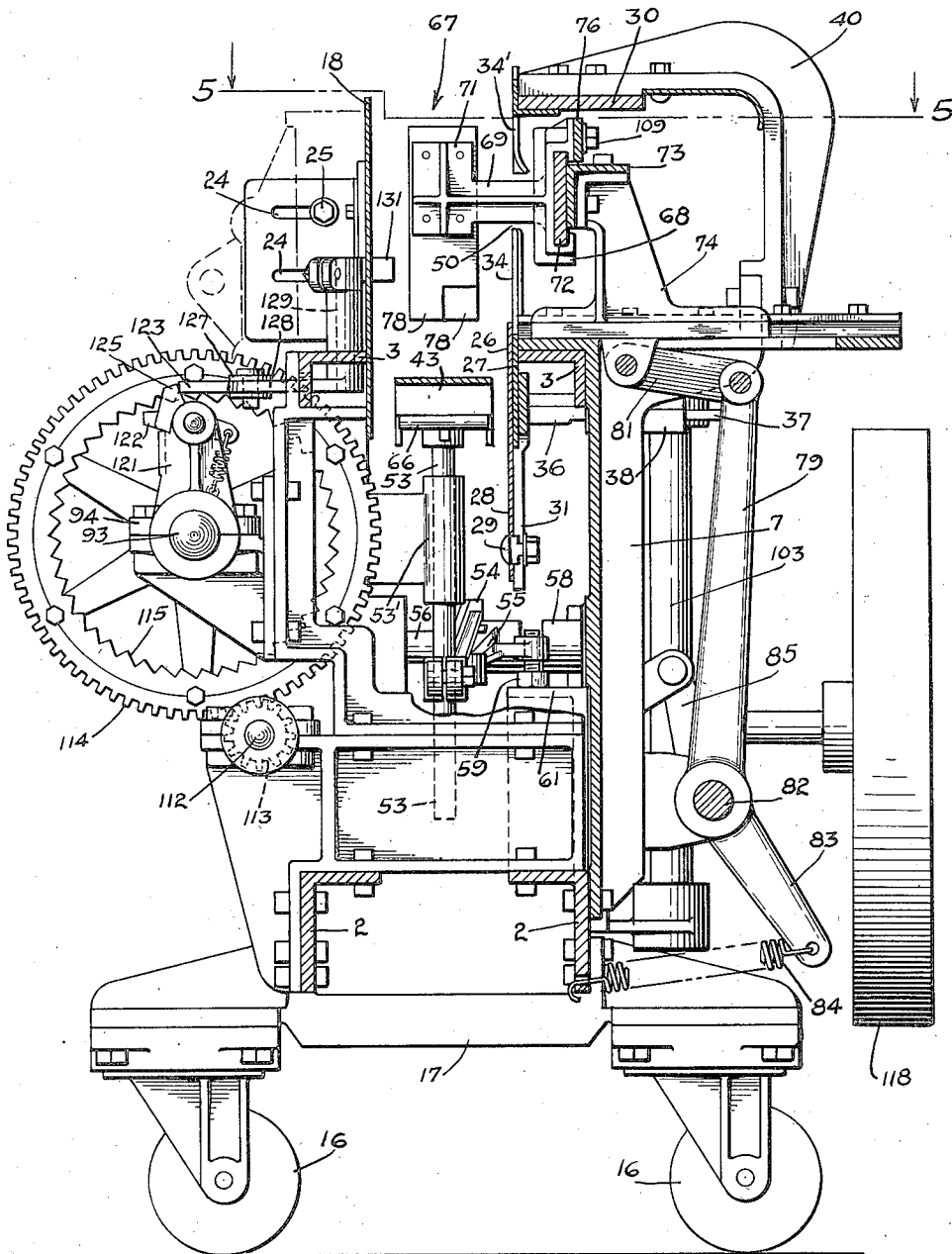

Fig. 6

INVENTOR.  
HELMER ANDERSON  
BY *Paul, Paul Moore*  
ATTORNEYS.

Aug. 20, 1935.

H. ANDERSON

2,011,839

FEEDING MECHANISM

Filed July 5, 1933

8 Sheets-Sheet 6

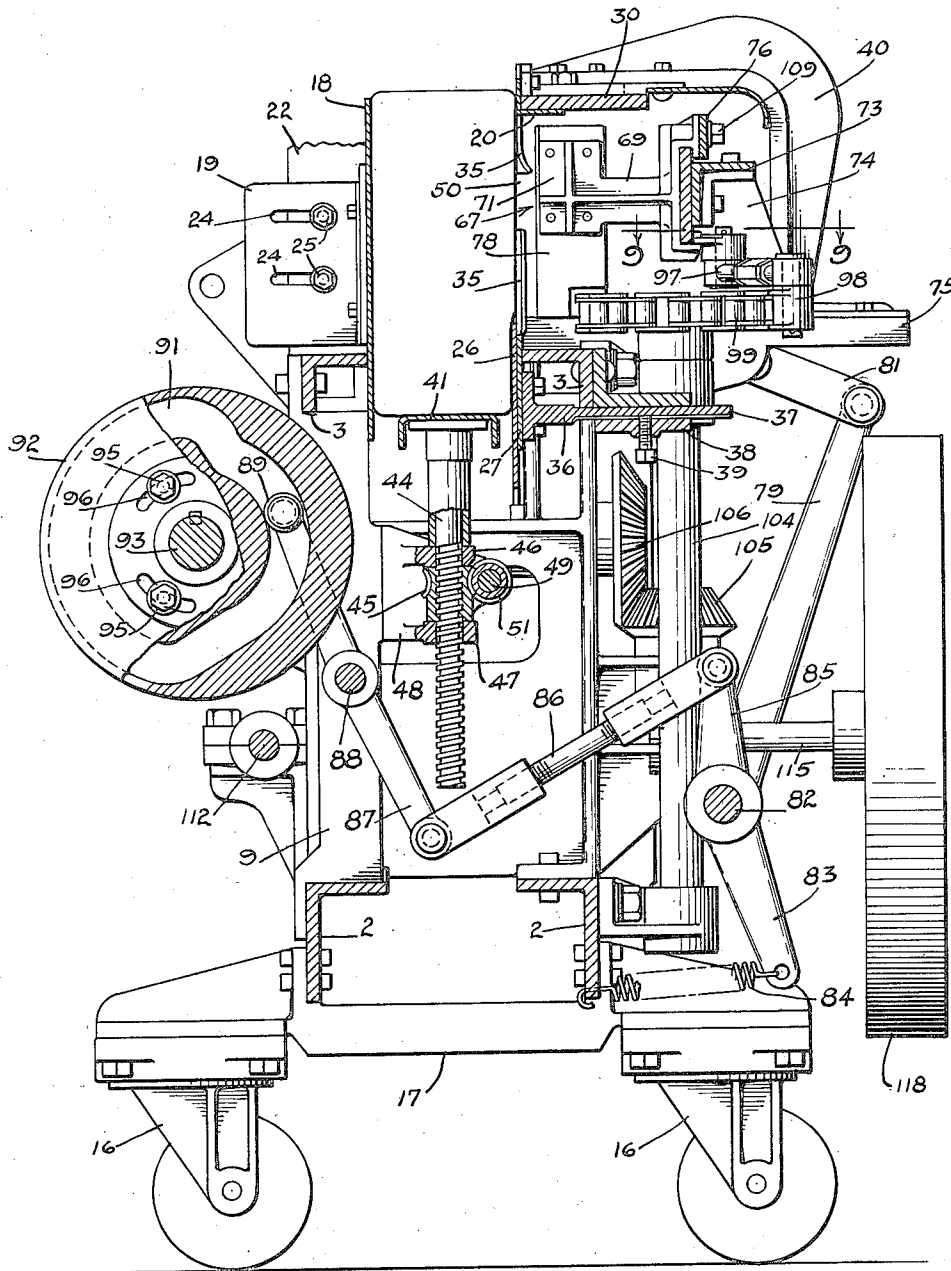

Fig. 7

INVENTOR.  
HELMER ANDERSON  
BY *Paul, Paul, Moore*  
ATTORNEYS.

Aug. 20, 1935.

H. ANDERSON

2,011,839

FEEDING MECHANISM

Filed July 5, 1933

8 Sheets-Sheet 7

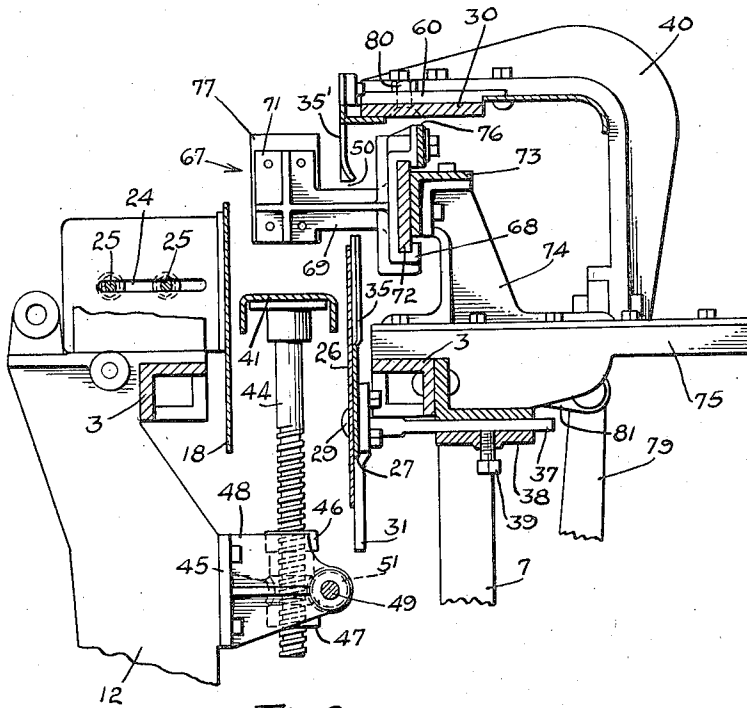

Fig. 8

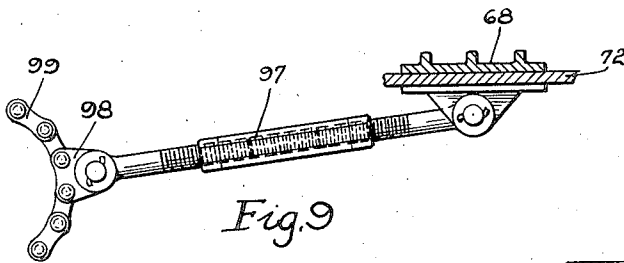

Fig. 9

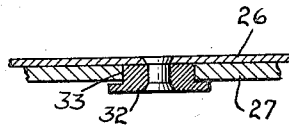

Fig. 10

INVENTOR.  
HELMER ANDERSON  
BY *Paul, Paul Nelson*  
ATTORNEYS.

Aug. 20, 1935.

H. ANDERSON

2,011,839

FEEDING MECHANISM

Filed July 5, 1933

8 Sheets-Sheet 8

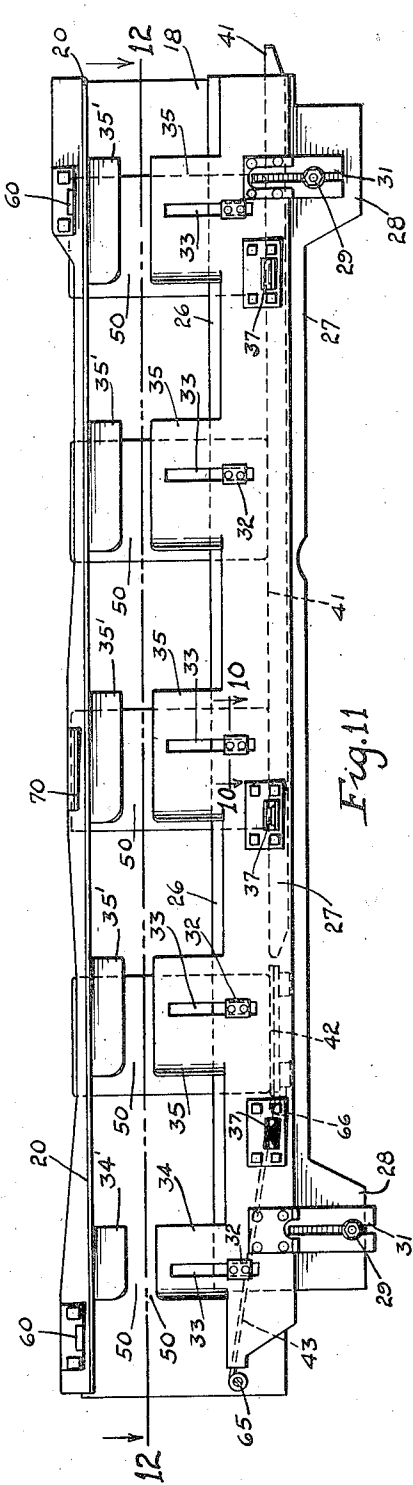

Fig. 11

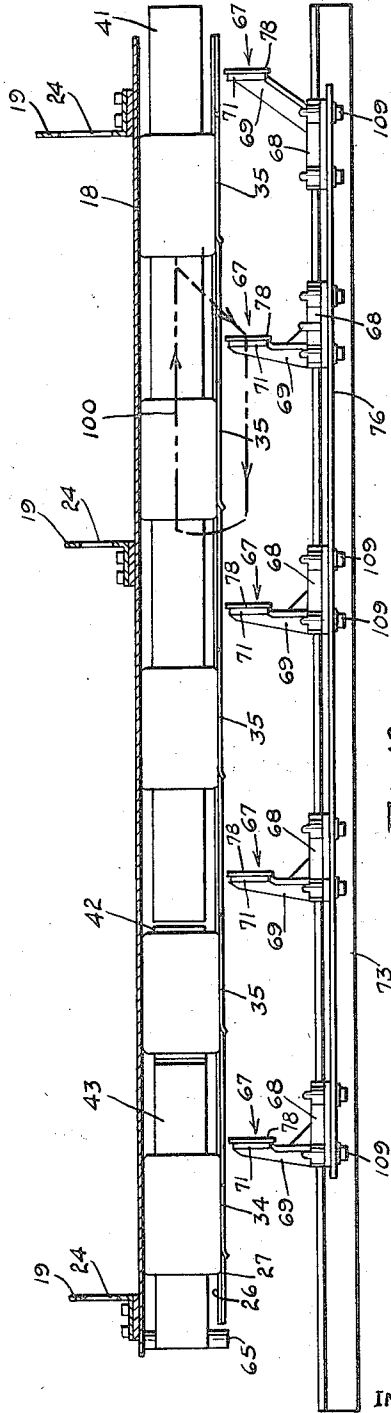

Fig. 12

INVENTOR  
HELMER ANDERSON  
By *Paul, Paul Moore*  
ATTORNEYS



# UNITED STATES PATENT OFFICE

2,011,839

## FEEDING MECHANISM

Helmer Anderson, Minneapolis, Minn., assignor  
to General Mills, Inc., Minneapolis, Minn., a  
corporation of Delaware

Application July 5, 1933, Serial No. 679,045

32 Claims. (Cl. 198—221)

This invention relates to an improved feeding mechanism for advancing commodities along a predetermined path of travel, while various operations are being performed upon the commodities as, for example, the closing of the open tops of filled containers.

The invention concerns itself more particularly with the provision of a novel feeding mechanism applicable for use in connection with bag closing and sealing, or packaging machines, of the general character disclosed in my Patent No. 1,772,824, issued August 12, 1930, and it has for an object to provide such a mechanism comprising a guideway along which the commodities or bags are intermittently fed by a series of connected and constantly operating pushers.

A further object is to provide a feeding mechanism comprising a guideway having spaced side walls, one of which is staggered in height to thereby provide a plurality of raised wall portions which cooperate with the other side wall of the guideway to provide a series of supporting means, spaced apart lengthwise of the guideway, and each adapted to receive and temporarily support a container or bag while work is being performed thereon by suitable mechanisms located at said raised wall portions or supporting means.

A further object is to provide a feeding mechanism particularly adapted for handling flexible containers such, for example, as paper bags, and comprising a guideway having spaced side walls, one of which has its upper edge staggered in height to provide a plurality of alternate high and low wall portions, and a series of pushers mounted adjacent to said guideway and having means for moving them into and out of the guideway over said low wall portions to thereby advance the bags or containers along the guideway in a step-by-step motion, the bags temporarily coming to rest at said raised wall portions which serve to support the bag bodies to prevent them from becoming distorted, when work is performed thereon to close and seal the open tops thereof.

A further object is to provide a mechanism of the class described, comprising a guideway having spaced side walls, one of which is composed of lower and upper sections, and the lower section having its upper edge staggered in height to provide a plurality of raised wall portions spaced apart lengthwise of the guideway, and the upper section comprising a plurality of downwardly extending wall portions substantially aligned with said raised wall portions and cooperating therewith to support the bag bodies, and said downwardly extending wall portions being so arranged

with respect to said raised wall portions as to permit a series of pushers to move into and out of the guideway from one side thereof to intermittently advance the bags or commodities along through the guideway.

Other objects reside in the provision of such a mechanism which is adjustable to bags and containers of various shapes and sizes; in the specific construction of the bottom wall of the guideway; in the particular arrangement and construction of the pushers, whereby they may be relatively adjusted to suit the spacing between the raised wall-supporting portions of the guideway; and, in the means for operating the pushers in timed relation to the delivery of bags into the guideway.

Other objects of the invention will appear from the following description and accompanying drawings and will be pointed out in the annexed claims.

In the accompanying drawings, there has been disclosed a structure designed to carry out the various objects of the invention, but it is to be understood that the invention is not confined to the exact features shown as various changes may be made within the scope of the claims which follow.

In the drawings:

Figure 1 is a side elevation of the novel feeding mechanism herein disclosed, showing the driving means for the pushers;

Figure 2 is a plan view of Figure 1, showing the pushers about to engage the bags in the guideway;

Figure 3 is a longitudinal sectional view on the line 3—3 of Figure 2, showing the means for relatively adjusting the bottom wall of the guideway, and also the means provided at intervals along the guideway to support the bags while work may be performed upon the tops thereof;

Figure 4 is a sectional plan view substantially on the line 4—4 of Figure 1, showing the operating mechanism for the pushers;

Figure 5 is a plan view of the guideway and pushers, other parts of the structure being omitted;

Figure 6 is a cross-sectional view on the line 6—6 of Figure 2, showing a portion of the mechanism for moving the pushers into and out of the guideway, and also the means for controlling the operation of the pushers;

Figure 7 is a cross-sectional view on the line 7—7 of Figure 2, showing the cam and lever mechanism for operating the pushers;

Figure 8 is a cross-sectional view on the line 8—8 of Figure 2, showing the guideway and

pushers adjusted for relatively smaller bags or containers;

Figure 9 is a detail sectional view on the line 9-9 of Figure 7;

Figure 10 is a detail sectional view on the line 10-10 of Figure 11;

Figure 11 is a side elevation of the guideway, showing the arrangement of the walls thereof, other parts of the structure being omitted for the sake of clarity; and

Figure 12 is a sectional plan view on the line 12-12 of Figure 11, showing in broken lines, the substantially rectangular path traveled by the pushers.

#### *Machine frame (Figures 1, 2, 3, 4, 6, and 7)*

The novel feeding mechanism herein disclosed is shown comprising a main supporting structure or frame comprising longitudinally extending lower frame members 2-2 and upper frame members 3-3, secured together in spaced relation by upright members 4, 5, 6, and 7 at the front side of the machine, and by similar upright members 8, 9, 11, and 12 at the rear of the machine. The lower side frame members 2 are connected together at the ends of the machine by integral cross members 13 and 14, and upright posts 15 are shown interposed between the frame members 2 and 3 at the ends of the frame, as shown in Figures 1, 3, and 4. The entire frame is shown supported upon suitable swivel casters 16, secured to the outer ends of cross members 17 bolted to the lower frame members 2, as clearly shown in Figures 6 and 7.

#### *Guideways (Figures 3, 6, 7, 8, 11 and 12)*

An important feature of this invention resides in the novel means provided for guiding the commodities or bags through the machine. As hereinbefore stated the feeding mechanism is particularly adapted for the handling of flexible containers such, for example, as paper bags, whose walls may readily be distorted, if the bag bodies are not properly supported while work is being performed upon the bags as, for example, the closing of the open tops thereof. The feeding mechanism herein disclosed, has been found particularly applicable for use in connection with bag closing and sealing machines such as disclosed in my patent, No. 1,772,824, hereinbefore mentioned, and Patent No. 1,772,823. The structures disclosed in these patents, when combined, form a machine comprising a plurality of mechanisms which operate upon the bag top walls and folds them into closing relation, after which a suitable gummed sealing strip is applied to the folded bag top to seal it. These various mechanisms are spaced apart lengthwise of the machine and provide a plurality of stations, at which stations each bag temporarily comes to rest, as the bags are fed through the machine, to thereby permit said mechanisms to operate upon the bag tops. The bag top closing and sealing mechanisms, above referred to, are clearly illustrated in the above mentioned patents and it is therefore thought unnecessary to illustrate them in the present application.

Because of the flexible nature of the walls of the bag bodies, it is necessary that means be provided for supporting the bag bodies while work is being performed upon the open tops thereof, in order to prevent distortion of the bag bodies, and the novel feeding mechanism herein disclosed is so constructed as to amply support

the bag bodies and, at the same time, permits them to be freely moved along through the machine through the various stations.

As shown in Figures 6, 7, 8, 11, and 12, the guideway comprises a side wall 18 having a plurality of brackets 19 suitably secured thereto which are adjustably supported upon upright frame members 21, 22, and 23, shown provided upon the upper longitudinal frame member 3 at the back of the machine. The brackets 19 are provided with suitable slots 24 adapted to receive clamping bolts 25 whereby the brackets may be adjustably secured to their supports to thereby permit lateral adjustment of the side wall 18, as when adjusting the guideway for bags of various sizes and shapes.

The opposite side wall of the guideway comprises two sections 26 and 27, the former being shown provided with depending portions 28 provided with bolts 29 adjustably secured to slotted brackets 31, whereby the wall section 26 may be vertically adjusted with respect to the wall section 27, which is secured to the machine frame, and is adapted for horizontal adjustment only. The upper portion of the wall section 26 is shown provided with flanged guide blocks 32 slidably mounted in slots 33 provided in a plurality of upstanding or raised wall portions 34 and 35 of the wall section 27. By thus constructing the wall section 27, it will be noted that the upper edge thereof is staggered in height. In other words, it is provided with a plurality of alternate high and low wall portions, as most clearly shown in Figure 11. The guide blocks 32 operatively connect together the two wall sections 26 and 27, so that when adjustably secured together for a given size bag, they will function as a single unitary wall structure.

The front wall of the guideway, composed of the wall sections 26 and 27, like the opposite wall 18, is adjustable towards and away from the longitudinal center line of the guideway, whereby the guideway may be adapted for bags of different widths to thus laterally adjust the wall sections 26 and 27. The wall section 27 is shown secured to a plurality of horizontally disposed brackets 35 having reduced extensions 37 slidably mounted in guides 38 and wherein they may be secured in adjusted position by suitable set screws 39, as clearly illustrated in Figures 7 and 8.

Disposed directly above the wall portions 34 and 35, and substantially vertically aligned therewith, are a plurality of downwardly extending wall portions 34' and 35' which are secured to a longitudinally extending member 20 adjustably secured to a supporting plate 30 by suitable brackets 60 and 70 and bolts 80, as shown in Figure 2. The lower edges of the wall portions 34' and 35' are spaced from the upper edges of the raised wall portions 34 and 35, as clearly shown in Figures 3 and 11, to thereby provide gaps 50 therebetween for reasons which will subsequently be described.

Another feature of the invention resides in the construction of the bottom wall of the guideway whereby it may readily be vertically adjusted to accommodate the guideway for bags of different heights. This bottom wall is shown composed of a channel member 41, a plate 42, and a pivoted member 43, provided at the receiving end of the machine. The channel member 41 is shown suitably secured to threaded rods 44 having worm wheels 45 received in threaded engagement therewith and supported between suitable guides 43

and 47 of brackets 48 shown secured to the portion 12 of the machine frame, as shown in Figure 8.

The means provided for relatively rotating the worm wheels 45 upon the threaded rods 44 is shown comprising a shaft 49 mounted in suitable bearings provided in the brackets 48, and having worms 51 thereon meshing with the worm wheels 45. When the shaft 49 is rotated, the worm gears 45 will be simultaneously rotated upon the rods 44 to thereby vertically adjust the bottom wall member 41, as will be readily understood by reference to Figures 3 and 7. The end of the shaft 49 is squared, as indicated at 52 in Figure 3, to receive a suitable wrench or crank, not shown, whereby it may be rotated.

The plate 42, forming a portion of the bottom wall of the guideway, is supported upon spaced rods 53, slidably mounted in suitable guides provided in a bracket 53'. A yoke 54 is adjustably secured to the rods 53 below the guide bracket 53', as shown in Figure 3. This yoke is operatively connected to an arm 55 secured to a shaft 56 mounted in suitable bearings 57 and 58 on the machine frame. A suitable adjusting screw 59 is mounted in the arm 55 and is adapted to engage the portion 61 of the machine frame, as shown in Figure 6, to thereby limit the downward movement of the yoke 54 and whereby the upper surface of the plate 42 may be horizontally aligned with the upper surface of the channel member 41.

Means is provided for rocking the shaft 56 to vertically move the plate 42 during operation of the machine, and is shown comprising an arm 62 having a roller 63 thereon adapted to be engaged by a cam 64, whereby the shaft will be rocked in its bearings to thereby elevate the plate 42.

The plate 42 has an important function to perform, when the guideway or feeding mechanism is used in connection with a bag closing and sealing machine, such as disclosed in my above mentioned patents, in that it exerts an upward pressure upon the bottoms of the bags during the final operation of folding the bag top walls to thereby square and shape the bag bodies. In some instances, it may be found desirable to dispense with the plate 42, in which case the channel member 41 may be lengthened so as to meet the pivoted bottom member 43.

The member 43 is supported at the receiving end of the machine by a suitable pivot 65, and has its opposite end supported upon an extension 66 provided upon the plate 42. By thus supporting the swinging end of the member 43 upon the plate 42, the member 43 will be relatively adjusted vertically when the plate 42 is adjusted. When adjusting the bottom wall members 41, 42, and 43, to adapt the machine for bags of different heights, it is to be understood that the plate 42 is so adjusted that its upper surface will be substantially aligned with the upper surface of the member 41, so as to prevent the lower portions of the bag bodies from interfering with the adjacent end of the member 41.

#### *Advancing means (Figures 2, 5, 6, 7, 8, and 12)*

Another important feature of this invention resides in the means provided for intermittently feeding or advancing the bags along through the guideway whereby the bags will temporarily come to rest between the bag body supporting wall portions 35-35' and the side wall 18, as best shown in Figures 11 and 12.

Such means is shown comprising a plurality of pushers, indicated generally by the numeral 67, and each comprising a body portion 68 provided with a lateral arm 69 having a terminal head 71, as shown in Figures 7 and 8. The body portion 68 of each pusher 67 is slidably supported upon a rail 72 secured to an angle iron 73 which, in turn, is secured to a plurality of brackets 74 slidably mounted in suitable guides 75 provided at the ends of the machine, as shown in Figures 1 and 5. The pushers 67 are secured together in spaced relation by a suitable tie bar 76, shown in Figures 6, 7, 8, and 12, whereby they are adapted for simultaneous operation when said tie bar 76 is reciprocated upon the rail 72.

To adapt the heads 71 of the pushers for bags of different heights, a plurality of plates 77 and 78 are provided which are interchangeably supported upon said heads, as shown in Figures 7 and 8. When the guideway is adjusted for handling relatively small bags, the shorter plates 77 are used, as shown in Figure 8, and when adjusted for handling larger bags, as in Figure 7, the longer plates 78 are used.

#### *Driving mechanism (Figures 1, 2, 4, 6, and 7)*

Means is provided for reciprocating the pushers, both laterally and lengthwise of the guideway, as indicated by the broken lines 100 in Figure 12, whereby the pushers will move into and out of the guideway to advance the bags in a step-by-step movement.

The means for moving the pushers laterally, or in and out of the guideway, is best shown in Figures 6 and 7, and comprises a pair of arms 79 having links 81 connecting them to the slidable brackets 74, as best shown in Figure 6. The arms 79 are secured to a rock shaft 82 mounted in suitable bearings on the machine frame. Each arm 79 is shown provided with an extension 83 having suitable tension springs 84 connected thereto. These springs are also connected to one of the lower frame members 2 of the machine frame to thereby constantly urge the arms 79 in a direction so as to take up any slack or play in the joints to thereby minimize noise.

An arm 85 is secured to the shaft 82 and has a connecting rod 86 connecting it to one end of an arm 87 supported upon a pivot 88 and having its opposite end provided with a roller 89 adapted to travel in a slot 91 provided in a cam 92 secured to a main operating shaft 93, mounted in suitable bearings 94 at the rear of the machine. The cam 92 is mounted for relative adjustment upon the shafts 93 by means of adjusting screws 95 received in arcuate slots 96 provided in the cam. The connecting rod 86 is adapted for longitudinal adjustment whereby the pushers may be laterally adjusted with respect to the longitudinal center line of the guideway.

The means provided for moving the pushers lengthwise of the guideway is best shown in Figures 1, 4, 5, and 7, and comprises a pitman 97 having one end pivotally connected to one of the pusher heads 68, and having its opposite end pivotally connected to a bracket 98 secured to one of the links of a suitable chain 99, mounted upon a pair of sprockets 101 and 102, as best shown in Figure 5. The sprockets 101 and 102 are secured to upright shafts 103 and 104, respectively, mounted in suitable bearings in the machine frame. The shaft 104 has secured thereto a pinion 105 which is driven by a gear 106 provided upon a horizontal shaft 107. The shaft 107 is operatively connected to the main operating shaft

93 by a suitable bevel gear drive 108, as shown in Figure 4. It will thus be seen that when the shaft 93 is rotated, the chain 99 will also be operated or rotated to thereby impart a longitudinal reciprocal movement to the tie bar 76 upon which the pushers are mounted. The pitman 97 is adapted for longitudinal adjustment, as will readily be understood by reference to Figure 5. In like manner, the pusher heads 68 are adjustably secured to the tie bar 76 by suitable bolts 109 received in slots 111 provided in the tie bar, as shown in Figure 1.

The means provided for driving the main operating shaft 93 is best shown in Figures 2 and 6, and comprises a drive shaft 112 having a pinion 113 meshing with a gear 114 secured to a ratchet 115 rotatably mounted upon the main operating shaft 93. The drive shaft 112 is connected at its opposite end to a cross shaft 115 by a suitable bevel gear drive 116, and the shaft 115 is shown operatively connected to a motor 117 by a suitable belt drive 118.

An arm 121 is secured to the main operating shaft 93 and carries a spring-actuated dog 122 adapted to engage the teeth of the ratchet 115. The dog 122 is normally held out of engagement with the ratchet by means of an arm 123, pivoted at 124 to the machine frame and adapted to engage an extension 125 on the dog, when the arm 121 is in the position shown in Figure 6.

The arm 123 has a link 127 connecting it to an arm 128 secured to one end of an upright shaft 129 upon the opposite end of which is mounted a trip 131 normally positioned in the path of travel of the bags, as shown in Figure 6. A suitable clearance opening is provided in the side wall 18 of the guideway to permit the trip 131 to swing freely therethrough. The arm 131 is adjustably mounted upon the shaft 129 whereby it may be positioned for smaller bags.

#### Operation

In the operation of this novel feeding mechanism, the bags are delivered into the guideway from the left hand end of the machine, when viewed as shown in Figure 2. The bags may be delivered thereto by manually placing them in the receiving end of the guideway, or by feeding them thereto by mechanical means, not shown. As each bag is moved along the guideway, it will engage the trip 131 and move it from the dotted to the full line position shown in Figure 2, whereupon the arm 123 will be moved out of engagement with the extension 125 of the dog 122, and thus permit the latter to move into driving engagement with the ratchet 115 to thereby cause the arm 121 to rotate with the ratchet, with the result that the operating shaft 93 is also rotated.

Such actuation of the operating shaft 93 will cause oscillation of the arms 73, whereby the slides 74 carrying the track or bar 72 upon which the pushers are mounted, will be moved towards the guideway from the position shown in Figure 7, to that shown in Figure 6, whereupon the heads 71 of the pushers 67 will move into the guideway in alinement with the bags positioned therein.

At the same time, the chain 99 will be rotated as a result of the shaft 104 being operatively connected with the operating shaft 93 by the gears 103, 105, and 106, which will cause the pushers to be reciprocated in a lengthwise direction upon the supporting track 72.

When feeding relatively large bags through the machine, the side walls of the guideway and also the bottom wall thereof may be adjusted to the

positions shown in Figures 6 and 7, wherein it will be noted that the relatively longer pusher plates 78 are secured to the heads 71 of the pushers so as to engage the major portions of the rear end walls of the bags as will be clearly understood by reference to Figure 6. During each cycle of operation, the blades 73 of the pushers will pass over the lower wall portions of the front wall section 27 between the raised portions 35 thereof, and the arms 69 of the pushers will travel through the gaps 50 provided between the wall portions 34 and 34', and 35 and 35', as will be clearly understood by reference to Figures 6 and 8.

Each bag will temporarily come to rest substantially in alinement with each raised wall portion 35 and its complemental depending portion 35', as the bags are intermittently fed through the machine, whereby the bag bodies will be supported at the sides so that when pressure is exerted upon the tops of the bag bodies by the bag top closing mechanisms, not shown, the bag bodies will not become distorted. When operating on relatively smaller bags, the side walls of the guideway may be moved inwardly to the position shown in Figure 8, and the bottom wall thereof moved upwardly as there shown, to thereby reduce the size of the guideway. When operating on small bags, the relatively smaller pusher blades or plates 77 are also substituted for the relatively larger pusher blades 78, shown in Figures 6 and 7. In order to adequately support the sides of the bag bodies, the wall section 26 of the front wall is also preferably moved upwardly, as shown in Figure 8, whereby the bag bodies will be adequately supported on both sides.

The pushers are so timed and adjusted that they will follow a path substantially as indicated by the broken lines 100 in Figure 12, wherein it will be noted that when they reach the limit of their forward movement, they are moved rearwardly on substantially a straight line, a predetermined distance, before they are moved out of the guideway. By relatively adjusting the cam 92 upon the shaft 93, and longitudinally adjusting the connecting rod 86 and the pitman 97, the path traveled by the latter may be varied to suit conditions.

The novel feeding mechanism herein disclosed is comparatively simple in construction, and readily lends itself for use in connection with bag closing and sealing machines. It has been found that the pushers may be operated at a comparatively high rate of speed, as they do not start with a full load, as does an endless conveyer chain having a plurality of flights thereon, such as shown in my patents, above mentioned. In the mechanisms herein disclosed, the pushers are in full motion before they engage the bags to advance them in the guideway, which makes it possible to feed the bags through the guideway at a higher rate of speed than is possible with an endless conveyer chain. The various parts of the machine may readily be adjusted to adapt it for handling bags of different sizes and shapes, which is an important factor in machines of this character for the reason that numerous commodities are now dispensed in small bags or containers weighing from 1 to 7 or more pounds.

I claim as my invention:

1. In a feeding mechanism, a guideway comprising spaced side walls, one of which is staggered in height, a plurality of pushers for advancing commodities along said guideway, and means for imparting longitudinal and lateral reciprocal movements to said pushers in a horizontal plane

to move them into and out of the guideway between the raised portions of said staggered wall.

2. In a feeding mechanism, a guideway comprising spaced side walls, one of which is staggered in height, and means for advancing commodities along said guideway, including a series of pushers movable into and out of the guideway over the lowermost portions of said staggered wall, and in a given plane.

3. In a feeding mechanism, a guideway comprising spaced walls, one of which has a staggered edge thereby to provide a plurality of projecting portions spaced apart lengthwise of the guideway, and means for intermittently advancing commodities along said guideway, including a series of connected pushers movable into and out of the guideway between the projecting portions of said staggered wall, said projecting portions serving to support commodities in the guideway to permit work to be performed thereon.

4. In a feeding mechanism, a guideway comprising spaced side walls, one of which has its upper edge staggered in height, means for advancing commodities along said guideway, including a series of pushers, and means for simultaneously operating said pushers in an angular horizontal path whereby they will move into and out of the guideway over the lowermost portions of said staggered wall.

5. In a feeding mechanism, a guideway comprising spaced side walls, one of which is staggered in height to thereby provide a plurality of raised wall portions spaced apart lengthwise of the guideway, and means for advancing commodities along said guideway, comprising a series of connected pushers movable into and out of the guideway between said raised wall portions, and in a given plane.

6. In a feeding mechanism, a guideway comprising spaced side walls, one of which is staggered in height to thereby provide a plurality of raised wall portions spaced apart lengthwise of the guideway, means for varying the spacing between said walls, means for advancing commodities along said guideway, comprising a series of pushers movable into and out of the guideway between said raised wall portions in a given plane, and an operating member common to all of said pushers.

7. In a feeding mechanism, a guideway comprising a bottom member and spaced side walls, one of said side walls having its upper edge staggered in height to provide a plurality of upstanding wall portions, spaced apart lengthwise of the guideway, means movable into and out of the guideway between said upstanding wall portions for advancing commodities along said guideway, and means for relatively vertically moving one of said side walls.

8. In a feeding mechanism, a guideway comprising an articulated bottom member and spaced side walls, means for varying the spacing between said side walls to adapt the guideway for commodities of varying sizes, means movable into and out of the guideway for advancing commodities lengthwise therethrough, and means for relatively vertically adjusting said bottom member.

9. In a feeding mechanism, a guideway comprising an articulated bottom member and spaced side walls, one of said side walls having its upper edge staggered in height to provide a plurality of raised wall portions spaced apart lengthwise of the guideway, means movable into and out of the guideway between said raised wall portions for advancing articles along said guide-

way, and means for relatively vertically moving one of said side walls.

10. In a feeding mechanism, a guideway comprising spaced walls between which the bags are advanced, one of said walls comprising a plurality of alternate high and low portions, and a member having means for moving it into and out of the guideway over adjacent low wall portions to thereby advance the bags along the guideway.

11. In a feeding mechanism, a guideway along which the bags are advanced, said guideway comprising spaced side walls and a bottom wall, one of said side walls comprising a plurality of alternate high and low portions, and a member for advancing the bags along said guideway, said member being movable into and out of the guideway over adjacent low wall portions.

12. In a feeding mechanism, a guideway along which the bags are advanced, said guideway comprising opposed side walls and a bottom wall, one of said side walls comprising a plurality of alternate high and low portions, a member having means for moving it into and out of the guideway over adjacent low wall portions to thereby advance the bags along the guideway, and means whereby said side and bottom walls may be relatively adjusted to vary the size of the guideway.

13. In a feeding mechanism, a guideway along which the bags are advanced, said guideway comprising spaced side walls and a bottom wall, one of said walls comprising a plurality of alternate high and low portions, a member for advancing the bags along said guideway, means for moving said member into and out of the guideway over said low wall portions and whereby the bags will temporarily come to rest at said high wall portions, and means for vertically adjusting the bottom wall to adapt the guideway for bags of varying heights.

14. In a feeding mechanism, a guideway comprising spaced walls between which the bags are advanced, one of said walls comprising a plurality of alternate high and low portions, a plurality of members for intermittently advancing the bags along said guideway, means for moving said members into and out of the guideway over adjacent low wall portions and whereby the bags will come to rest at said high wall portions, and means for varying the size of the guideway to adapt it for bags of different sizes.

15. In a feeding mechanism, a guideway comprising spaced walls between which the bags are advanced, one of said walls being staggered in height and comprising a series of alternate high and low portions, a plurality of members for advancing the bags along said guideway, and means for imparting uninterrupted movement to said members and whereby they are moved into and out of the guideway over adjacent low wall portions to intermittently advance the bags along the guideway.

16. In a feeding mechanism, a guideway comprising spaced walls between which the bags are advanced, one of said walls being staggered in height and comprising a plurality of alternate high and low portions, a member for advancing the bags along said guideway, and means for moving said member into and out of the guideway over adjacent low wall portions, whereby the bags will come to rest opposite said high wall portions to be temporarily supported thereby, and whereby work may be performed upon the bags while thus supported.



17. In a feeding mechanism comprising spaced side walls and a bottom wall cooperating to provide a guideway for the bags, one of said side walls being staggered in height to provide a plurality of alternate high and low portions, a plurality of members for intermittently advancing the bags along said guideway, and means for moving said members into and out of the guideway over said low wall portions and causing the bags to temporarily come to rest opposite the high portions of said staggered wall, whereby they will be supported by said high wall portions and thereby permit work to be performed upon the bags while thus supported.

18. In a mechanism for advancing filled flexible containers along a predetermined path, a guideway comprising spaced side walls, one of which is composed of upper and lower sections, said lower section having its upper edge formed with a plurality of raised wall portions spaced apart lengthwise of the guideway, and said upper section having a plurality of downwardly extending wall portions cooperating with said raised wall portions to provide a plurality of supports for filled containers fed along said guideway, and means for advancing the containers.

19. In a mechanism for advancing filled bags along a predetermined path, a guideway comprising spaced side walls, one of which is composed of upper and lower sections, said lower section having its upper edge formed with a plurality of raised wall portions spaced apart lengthwise of the guideway, and said upper section having a plurality of downwardly extending wall portions cooperating with said raised wall portions to provide a plurality of supports for filled bags fed along said guideway, the adjacent edges of said upper and lower wall portions being spaced apart to provide gaps therebetween, and means for intermittently advancing the bags along said guideway.

20. In a feeding mechanism for advancing filled bags along a predetermined path, a guideway comprising spaced side walls, one of which is composed of upper and lower sections, said lower section having its upper edge formed with a plurality of raised wall portions spaced apart lengthwise of the guideway, and said upper section having a plurality of downwardly extending wall portions cooperating with said raised wall portions to provide a plurality of spaced supports for filled bags fed along said guideway, the adjacent edges of said upper and lower wall portions being spaced apart to provide gaps therebetween, and means for intermittently advancing the bags along said guideway, comprising a plurality of pushers movable into and out of the guideway between said raised wall portions.

21. In a mechanism for advancing filled bags along a predetermined path, a guideway comprising spaced side walls, one of which is composed of upper and lower sections, said lower section having its upper edge formed with a plurality of raised wall portions spaced apart lengthwise of the guideway, and said upper section comprising a plurality of downwardly extending wall portions, alined with said raised wall portions and spaced therefrom vertically to provide elongated gaps, said raised and depending wall portions cooperating to provide a plurality of supports for filled bags, and a series of pushers for intermittently advancing the filled bags along the guideway and whereby they will temporarily come to rest at said supports.

22. In a mechanism for advancing filled bags

along a predetermined path, a guideway comprising spaced side walls, one of which is composed of upper and lower sections, said lower section having its upper edge staggered vertically to provide a plurality of raised wall portions spaced apart lengthwise of the guideway, and said upper section comprising a plurality of downwardly extending wall portions, alined with said raised wall portions and spaced therefrom vertically to provide elongated gaps between said complementary wall portions, said raised and depending wall portions cooperating to provide a plurality of supports for the bodies of the filled bags, a series of pushers for intermittently advancing the filled bags and causing them to temporarily come to rest at said supports, and means for operating said pushers, whereby they will move into and out of the guideway between the bag-supporting wall portions thereof.

23. In a mechanism for advancing filled bags along a predetermined path, a guideway comprising spaced side walls, one of which is composed of upper and lower sections, said lower section having its upper edge staggered in height to provide a plurality of raised wall portions spaced apart lengthwise of the guideway, and said upper section comprising a plurality of downwardly extending wall portions, alined with said raised wall portions and having their lower edges spaced therefrom to provide elongated gaps in said side wall, said raised and depending wall portions cooperating to provide means for supporting the bag bodies at intervals along the guideway, a series of connected pushers for intermittently advancing the filled bags and causing them to temporarily come to rest at said supporting means, means for operating said pushers in a horizontal plane, whereby they will move into and out of said guideway between the bag-supporting wall portions thereof, and means by which the walls of the guideway may be vertically adjusted to adapt the mechanism for handling commodities of varying sizes.

24. In an apparatus for advancing filled containers along a predetermined path, a guideway comprising a bottom and spaced side walls, one of said side walls being staggered in height and comprising a plurality of alternate high and low wall portions, said high wall portions forming supports for containers fed through the guideway, means for varying the height of said low wall portions to adapt the guideway for containers of different sizes, and means movable into and out of the guideway for advancing the containers there-through.

25. In an apparatus for advancing filled containers along a predetermined path, a guideway comprising a bottom and spaced side walls, one of said side walls being staggered in height and comprising a plurality of alternate high and low wall portions, said high wall portions forming supports for containers passing through the guideway, and said staggered wall comprising two plate elements secured together in flatwise relation and vertically adjustable with respect to each other, whereby the upper edges of said low wall portions may be varied in height to adapt the guideway for handling containers of different sizes, and means movable into and out of the guideway for advancing the containers there-through.

26. In an apparatus for advancing filled containers along a predetermined path, a guideway comprising a bottom and spaced side walls, one of said side walls being composed of upper and

lower sections spaced apart vertically to provide a passage therebetween, and means movable into and out of the guideway through said passage, adapted to engage containers delivered thereto and advance them along the guideway in spaced relation.

27. In an apparatus for advancing filled containers along a predetermined path, a guideway comprising a bottom and spaced side walls, one of said side walls being composed of upper and lower sections spaced apart vertically to provide a horizontal passage therebetween, advancing means movable into and out of the guideway through said passage, adapted to engage containers delivered thereto and advance them along the guideway in a step-by-step movement, and means by which certain walls of said guideway may be adjusted independently of the others, to thereby adapt the guideway for handling containers of different sizes.

28. In a mechanism of the class described, a guideway comprising a bottom wall and spaced side walls, one of said side walls being staggered in height to thereby provide a plurality of raised wall portions spaced apart lengthwise of the guideway, means movable into and out of the guideway between said raised wall portions for advancing commodities along the guideway, means whereby one of said side walls may be adjusted both vertically and horizontally to adapt the guideway for commodities of different sizes, and means for relatively adjusting said bottom wall.

29. In a mechanism of the class described, a guideway comprising a bottom wall and spaced side walls, one of said side walls comprising upper and lower sections, said lower section being formed with a plurality of raised wall portions spaced apart lengthwise of the guideway, and said upper section having depending wall portions aligned with said raised wall portions and having their lower edges spaced from the upper edges of said raised

wall portions, and means movable into and out of the guideway between said wall sections for advancing commodities along the guideway.

30. In a mechanism of the class described, a guideway comprising a bottom wall and spaced side walls, one of said side walls comprising upper and lower sections, said lower section being formed with a plurality of raised wall portions spaced apart lengthwise of the guideway, and said upper section having depending wall portions whose lower edges are spaced from the upper edges of said raised wall portions, means movable into and out of the guideway between said wall sections for advancing commodities along the guideway, and means for relatively adjusting the spacing between said wall sections to thereby adapt the guideway for commodities of different sizes.

31. In a mechanism of the class described, a guideway comprising a bottom wall and spaced side walls, one of said side walls being staggered in height, thereby to provide a plurality of raised wall portions spaced apart lengthwise of the guideway, means whereby said raised wall portions may be relatively adjusted in height with respect to the lower wall portions of said side wall, and means movable into and out of the guideway between said raised wall portions for advancing commodities along the guideway.

32. In a mechanism of the class described, a guideway comprising a pivoted bottom wall and spaced side walls, one of said side walls being staggered in height, thereby to provide a plurality of raised wall portions spaced apart lengthwise of the guideway, means whereby said raised wall portions may be relatively adjusted in height with respect to the lower wall portions of said side wall, and means movable into and out of the guideway between said raised wall portions for advancing commodities along the guideway.

HELMER ANDERSON.

40