

No. 718,885.

PATENTED JAN. 20, 1903.

W. STEPHENSON.  
SCRAPER FOR DISK SEED DRILLS.  
APPLICATION FILED MAY 24, 1902.

NO MODEL.

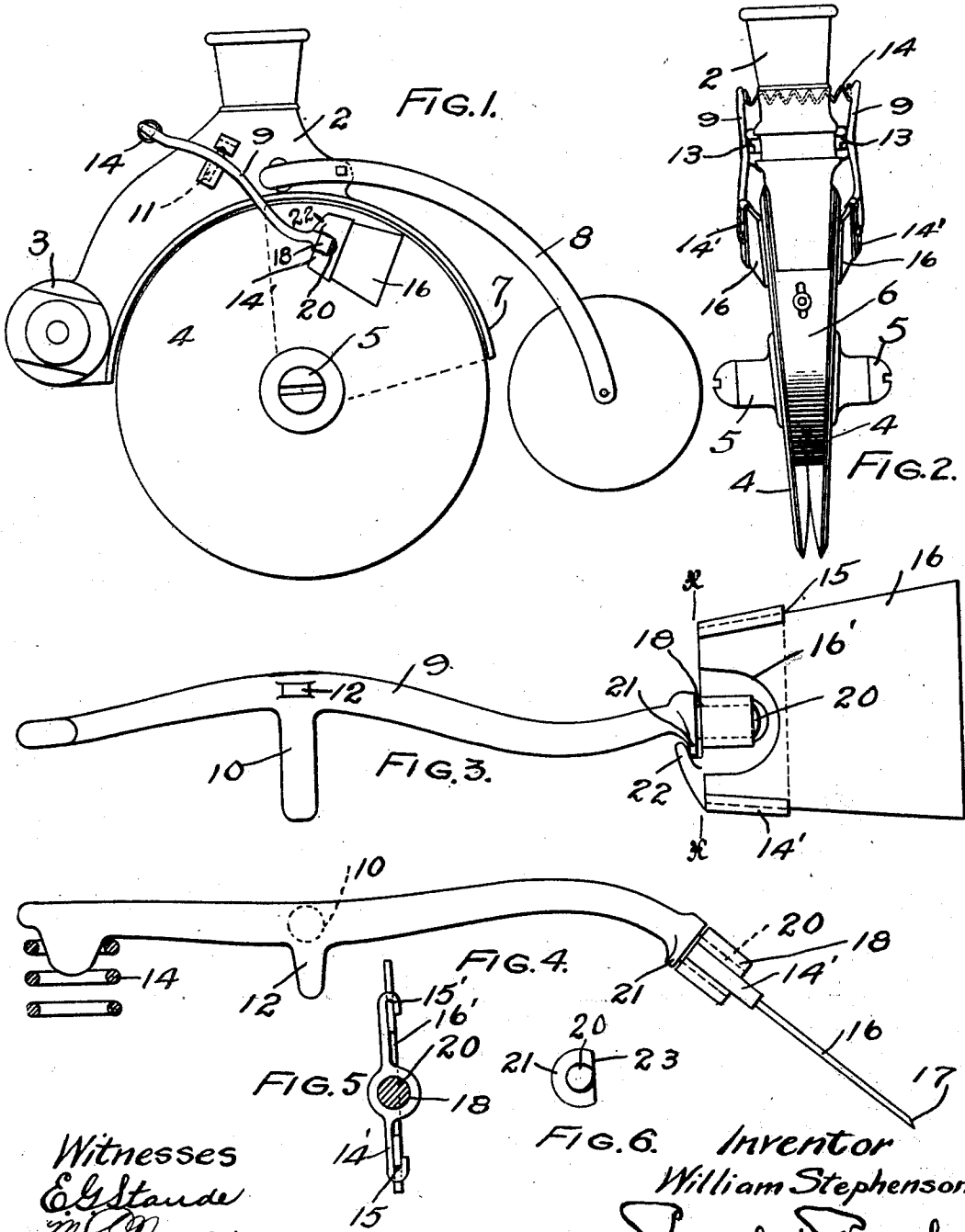

Witnesses  
E. Stande  
M. Spoonau

FIG. 5. FIG. 6. Inventor  
William Stephenson  
By Paul Paul  
his attorneys

# UNITED STATES PATENT OFFICE.

WILLIAM STEPHENSON, OF ST. LOUIS PARK, MINNESOTA.

## SCRAPER FOR DISK SEED-DRILLS.

SPECIFICATION forming part of Letters Patent No. 718,885, dated January 20, 1903.

Application filed May 24, 1902. Serial No. 108,779. (No model.)

*To all whom it may concern:*

Be it known that I, WILLIAM STEPHENSON, a citizen of the Dominion of Canada, residing at St. Louis Park, county of Hennepin, State of Minnesota, have invented certain new and useful Improvements in Scrapers for Disk Seed-Drills, of which the following is a specification.

My invention relates to disk seed-drills, and particularly to the cleaning or scraping plates therefor, and is designed as an improvement over similar devices of this kind shown and described in Letters Patent of the United States Nos. 624,117, 624,118, and 624,119, issued to me May 2, 1899.

In the operation of a disk seed-drill in wet weather or in heavy sticky soil it has been found necessary to provide scraper devices for keeping the surfaces of the disks near their circumferences clear of the mud and other sticky substances that cling thereto in order that the edges of the disks will enter the ground the proper distance for seeding, all of which has been heretofore fully described in Letters Patent above referred to. The scraper devices which I employ consist, preferably, of steel plates having sharpened beveled edges which bear upon the surfaces of the disks at an angle thereto and keep them clean and bright. It sometimes happens, however, that where a machine has stood out of doors in wet weather and the surfaces of the disks have become rusted or is in use in a soil of a peculiarly sticky nature a thin coating of dirt will collect on the disks and the beveled edges of the scrapers will be lifted thereby off the surfaces of the disks and allow them to revolve without being thoroughly cleaned. At such times I have found it desirable to reverse the position of the scrapers on their pivots, so that the straight edges thereof will bear upon the disks and digging into the thin sticky coating formed thereon effectually remove the same.

In the scrapers as heretofore constructed I have arranged the eyes or sockets wherein the pivots are inserted on one side of the plate, preferably next to the disks, and adjusted the tension-springs accordingly; but I have found that when the scrapers were reversed with the eyes on the opposite or out-

side the angle of the plates with respect to the disks would be changed and also the tension of the springs, necessitating the readjustment of the springs and the angle of the plates with respect to the disks, or to avoid changing the tension of the springs the removal of the plates from the casting wherein they are supported and readjusting them to bring their beveled edges to the outside.

The object, therefore, of my present invention is to obviate the necessity of removing the scraper-plates from their castings or holders and also to provide for the same tension of the springs and the same angle of the plates with respect to the disks whether the plates are arranged with their beveled edges bearing on the disks or reversed.

A further object of the invention is to provide means for preventing the scraper-plates from becoming accidentally disengaged from their pivots.

The invention consists generally in providing a scraper holder or head having a socket or eye with respect to which the scraper-plate is centrally arranged.

Further, the invention consists in arranging the socket on the end of the plate at one side of the center.

Further, the invention consists in providing an arm or lever having a flange on one side to engage a stop on the scraper-holder and prevent the accidental disengagement of lever from the holder when the parts are in their working position, said lever having a flat face opposite said flange to permit the disengagement of the scraper-holder from the lever when the parts are revolved to a certain predetermined point.

Further, the invention consists in various constructions and combinations, all as hereinafter described, and particularly pointed out in the claims.

In the accompanying drawings, forming part of this specification, Figure 1 is a side elevation of a seeder-disk with my invention applied thereto. Fig. 2 is a rear view of the same. Fig. 3 is a plan view of one of the scraper-blades and its lever. Fig. 4 is an edge view of the same. Fig. 5 is a section looking toward the right on the line  $x x$  of

Fig. 3. Fig. 6 is an end view of the scraper-lever, showing the flange and the flat face thereon.

In the drawings, 2 represents a grain-spout casting having a projection 3, whereto the usual draw-bar is attached.

4 represents the disks mounted upon the axle 5 and provided with the central scraper 6, corresponding substantially to the one described and claimed in my patents above referred to.

7 is the rear bracket-frame connecting the upper part of the oil-conduit with the lower part thereof, and 8 the usual press-wheel arms.

9 represents the scraper-levers having studs 10, that are adapted to fit loosely in sockets 11 on the grain-spout casting, and these levers are preferably provided with lugs 12, which when the levers are swung around to their operative position slip under flanges or projections 13 on the said casting and prevent the lever-studs from becoming accidentally disengaged from their sockets. The levers are arranged substantially as shown in Fig. 1, with their upper ends connected by the spring 14, which tends to hold said ends apart, while the opposite ends are pressed toward each other to hold the scraper-plates 30 upon the surfaces of the disks with a yielding pressure.

14' represents the scraper-holders having converging grooves 15 to receive the scraper-plates 16, as heretofore described in my former patents.

The plates are preferably tapered, as shown, and have beveled edges 17, which bear upon the surfaces of the disks and clean off the mud and other sticky material that may cling thereto as the disks revolve. The scraper-plates 16 are provided with recesses 16' in one end to receive sockets or eyes 18, provided on the scraper-holders and with respect to which the plates are centrally arranged. In other words, the centers of the sockets are substantially parallel with the longitudinal axes of the scrapers, and these sockets are swiveled on studs 20, provided on the ends of the levers 9, which have flanges 21 to engage stops 22 on the scraper-holders and prevent the disengagement of the scrapers from their levers when in their working position. The flanges on one side are cut away, forming flat surfaces 23, and by revolving the scraper-holders so that the stops will be opposite said flat surfaces the scrapers, with their holders, may be easily disengaged from the levers and turned to bring either the beveled or straight edges of the scrapers to bear upon the disks. The swiveled connection of the scraper-plates will allow them to adjust themselves automatically to the surfaces of the disks and accommodate themselves to any inequalities thereon, while the springs will hold the edges of said plates against the surfaces of the disks and effectually clean off whatever material may cling thereto.

Whenever it is desired to apply the straight edge of the scraper-blades to the disks, they can be readily detached from their levers by partially revolving them and reversing their position without changing their angle with respect to the disks or altering the tension of the springs.

As shown in the drawings, I have arranged the scraper-holder sockets at one side of the center of the plates to cause the inner ends of their beveled edges (which bear upon annular sections of the disks that move slower than the sections the outer ends bear upon, and hence do not wear as rapidly) to be held with greater pressure on the disks to equalize the wear of the ends of the plates.

I claim as my invention—

1. In a disk seed-drill, the combination, with a grain-spout, of the revolving disks, scraper-plates adapted to bear upon the surfaces of said disks at an angle thereto and having sockets or eyes, pivoted spring-actuated levers having ends that are swiveled in said sockets, and the centers of said sockets being in line substantially with the plane of said plates to permit reversal of said plates without changing the tension of the lever-springs or the angle of the plates on said disks, for the purpose specified.

2. In a disk seed-drill, the combination, with a grain-spout, of the revolving disks, scraper-holders having sockets, spring-actuated levers pivoted on said spout and having ends that are swiveled in said sockets, plates removably mounted in said holders, the planes of said plates and the centers of said sockets being substantially in line whereby the reversal of said plates is permitted without changing the tension of the lever-springs or the angle of the plates on their disks.

3. In a disk seed-drill, a scraper device comprising a holder having a socket, a spring-pressed pivoted lever having an end that is swiveled in said socket, and a plate carried by said holder with its plane in line substantially with the center of said socket, substantially as described and for the purpose specified.

4. In a disk seed-drill, a scraper device comprising a scraper-plate, a scraper-holder having a socket at one side of the center of said plate, and a spring-pressed pivoted lever whereon said socket is swiveled, the side edge of said plate that is farther from the center of said socket being nearer the edge of the disk than the opposite side edge of said plate, for the purpose specified.

5. In a disk seed-drill, a scraper device, comprising a scraper-plate having a socket with its center substantially in line with the plane of said plate and on one side of the center thereof, and a spring-pressed pivoted lever having a stud whereon said socket is swiveled, the side edge of said plate that is farther from the center of said socket being nearer the edge of its disk than the other edge of said plate, for the purpose specified.

6. In a diskseed-drill, a scraper device, comprising a pivoted lever having a flange near one end and an opposite flat face, a scraper-holder having a socket to receive the end of  
5 said lever and a lug to engage said flange and lock said holder and lever together, but permitting them to be separated when said lug is revolved to a point opposite said flat surface, and a scraper-plate carried by said  
10 holder.

7. In a diskseed-drill, a scraper device, comprising a pivoted lever having a flange near one end, a scraper-holder having a socket to

receive the end of said lever and a lug cooperating with said flange to lock said holder 15 on said lever when in a working position, and to permit its removal therefrom when in a non-working position, and a scraper-plate carried by said holder.

In witness whereof I have hereunto set my 20 hand this 12th day of May, 1902.

WILLIAM STEPHENSON.

In presence of—  
RICHARD PAUL,  
M. C. NOONAN.