

July 12, 1927.

1,635,315

C. F. EHINGER

AUTOMOBILE FAN

Filed Oct. 19, 1925

2 Sheets-Sheet 1

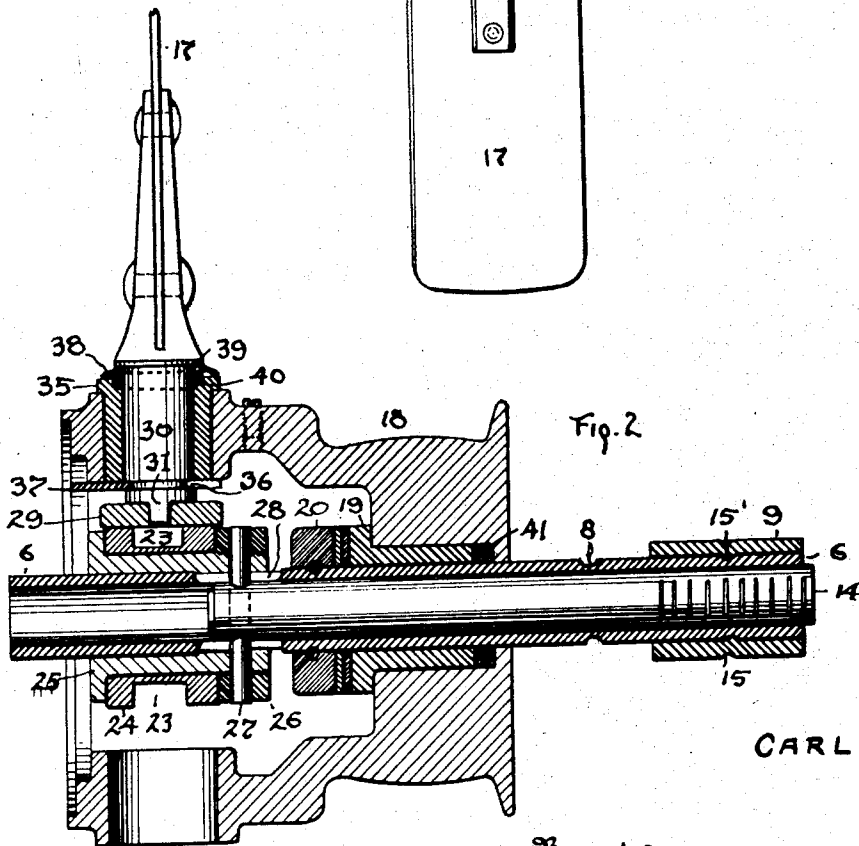
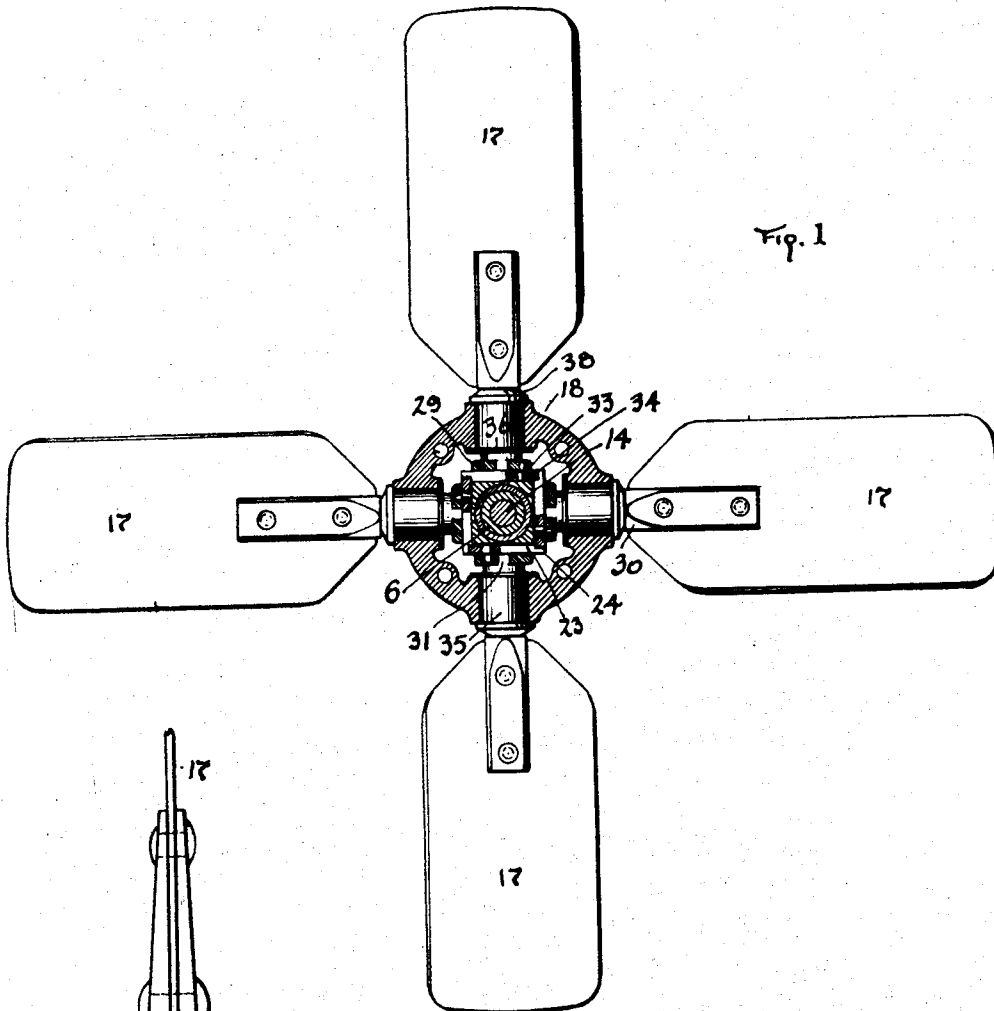

Inventor  
CARL F. EHINGER

By Fisher, Mow & Mook,  
Attorney

July 12, 1927.

1,635,315

C. F. EHINGER

AUTOMOBILE FAN

Filed Oct. 19, 1925

2 Sheets-Sheet 2

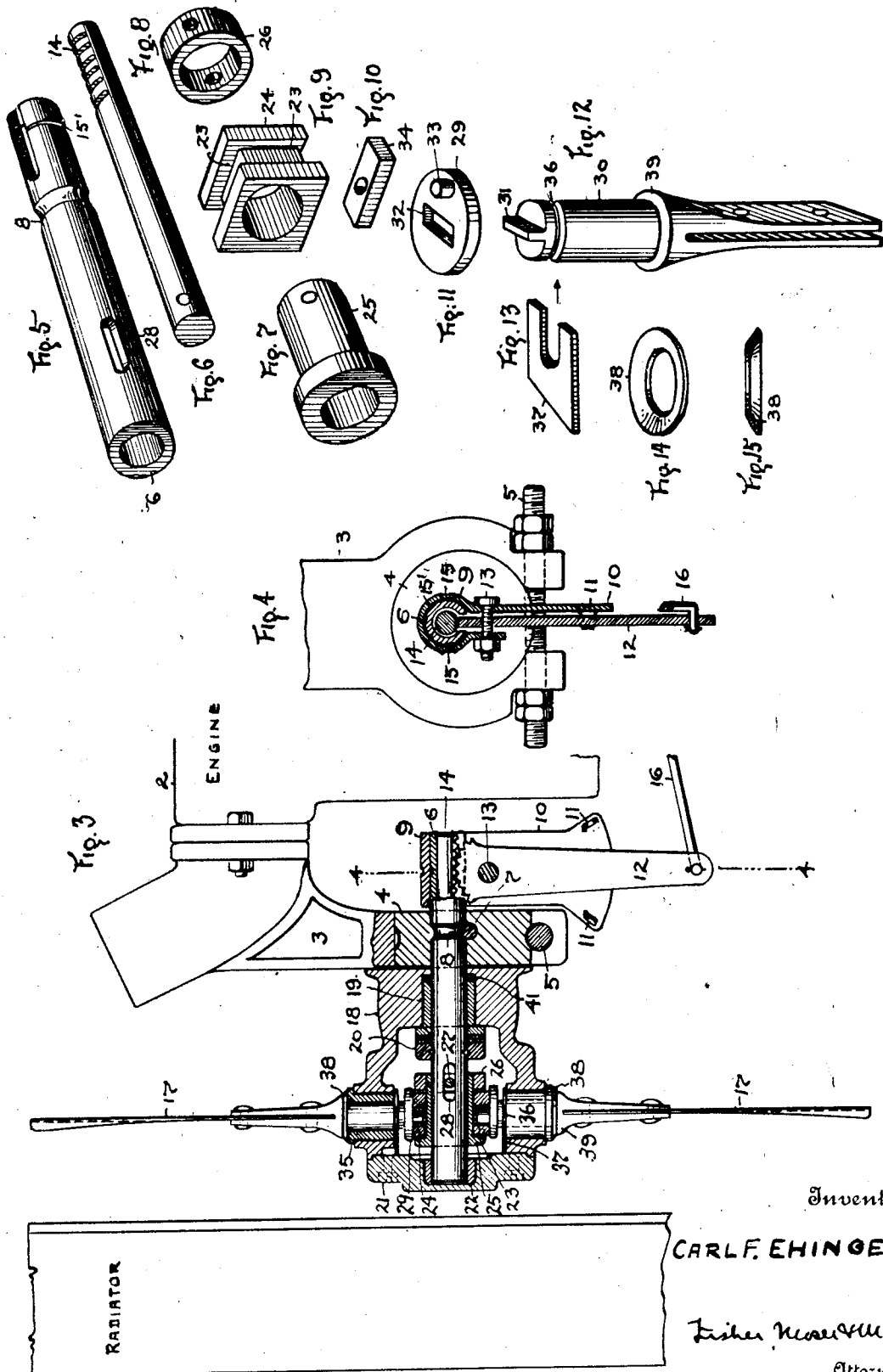

Inventor

CARL F. EHINGER.

Fisher, Nease & Moore

Attorney

# UNITED STATES PATENT OFFICE.

CARL F. EHINGER, OF CLEVELAND, OHIO.

## AUTOMOBILE FAN.

Application filed October 19, 1925. Serial No. 63,343.

My invention relates to an improvement in automobile fans, my object in general being to provide a rotatable fan having blades adapted to be turned to different working angles or to a neutral non-working position. As constructed the fan may be readily attached to automobile engines of known make in lieu of the fans used generally therewith, and suitable operating connections are provided to enable the driver of the car to shift the fan blades while the fan is revolving opposite the water-cooling radiator for the engine. Thus in cold weather the fan blades may be set substantially parallel with the face of the radiator to avoid forced circulation of air through the radiator during starting operations or at other times when it is desirable to conserve heat and promote operation of the engine. More specific objects of the invention are embodied in the detail construction of the fan; for example, the blades and operating parts are particularly constructed to facilitate the assembly and removal of individual parts such as the blades themselves; the blades are locked individually in place under spring tension; all the blades are further locked in place by a removable end plate or cover for the fan hub; and the operating mechanism for the fan blades comprises a lever and a special mounting therefor adapted to be easily attached, adjusted and fixed at different angles relatively to the engine body to permit an operating connection to be placed at one side of the engine.

In the accompanying drawings, Fig. 1 is a vertical cross section of the fan hub and a part elevation of the fan blades carried by the hub. Fig. 2 is an enlarged sectional view horizontally of the hub and its support and showing one fan blade attached to the hub which is minus its front cover plate. Fig. 3 is a vertical section of the fan mounted in place upon the engine at the rear of a water-cooling radiator. Fig. 4 is a cross section on line 4—4 of Fig. 3, showing the rotatable clamping bracket and the operating lever pivoted thereon. Fig. 5 to Fig. 15, inclusive, are perspective views of various parts of the fan, Fig. 5 showing the tubular supporting shaft; Fig. 6 delineating the operating rack; Figs. 7 and 8 illustrating the sliding sleeve or bushing and its removable collar, respectively; Fig. 9 displaying the square block which is rotatably

mounted upon the sliding sleeve; Fig. 10 revealing one of the rectangular slides used within the square block; Fig. 11 representing one of the eccentric operating disks which actuate the said block; Fig. 12 exhibiting one of the oscillating shafts for a fan blade; Fig. 13 portraying one of the locking keys for an oscillatory shaft; and Fig. 14 picturing one of the spring washers for taking up wear and applying a locking tension on a locking key. Fig. 15 is a sectional view of the same spring washer in its dished form as it appears when not under compression.

In Fig. 3 I show the front portion 2 of an engine having a clamping bracket 3 in which a round bushing 4 is adjustably held by a screw 5. A tubular shaft 6 extends through an opening in bushing 4, preferably in an eccentric position to the axis of the bushing, and a pin 7 or other device may be inserted in a groove 8 in the shaft to lock the shaft rigidly in the bushing. The rear end of the shaft extends a short distance toward the engine and carries a clamping sleeve 9 having a long arm 10 which is widened at its outer end and formed with spaced projections 11—11, see Fig. 3. These projections limit the swinging movement of a lever 12 which is pivotally mounted upon the clamping bolt 13 for sleeve 9, see Fig. 4, and the inner end of the lever is provided with teeth to engage other teeth on a rack bar 14 confined within shaft 6. To prevent the clamping sleeve from shifting lengthwise on shaft 6 the opposite sides of the sleeve are partly indented at 15 into an annular groove 15' in the shaft, but the clamping sleeve may be rotated together with the shaft to place the lever in either a horizontal or an inclined position. A rod 16 extends from the free end of lever 12 to the driver's seat and serves to oscillate the lever thereby reciprocating rack bar 14, and this reciprocable movement is utilized to oscillate a plurality of rotatable fan blades 17 carried by a revoluble hub or pulley 18 on the front part of shaft 6. Pulley 18 is driven by a belt (not shown) and is journaled on a metal bushing 19 and held in place in front of bracket 3 by thrust collars 20 sleeved upon the shaft. Pulley 18 is hollow in part and open at its front end except for a removable end plate or cover 21 which may also be provided with a bushing 22 to receive shaft 6. The fan blades 17 are

mounted radially of the pulley directly opposite straight channels 23 in a square block 24 which is rotatably mounted upon a round sleeve 25 free to slide on shaft 6 but not rotatable independently of the shaft, the sleeve having a detachable collar 26 to confine the block, and both the sleeve and its collar being locked to the shaft by a cross pin 27 extending through rack bar 14 and slots 28 in the shaft, see Figs. 2 and 3. Thus, the rack bar and shaft and the sleeve on the shaft are fixed together to prevent independent rotation but the rack bar and sleeve may be reciprocated within limits on the shaft to impart like reciprocable movements to rotatable block 24 which is engaged on all four sides by flat disks 29 fixed to the inner ends of the spindles 30 for the fan blades. Thus, each spindle has a flat tongue 31 which extends into a central slot 32 in the disk, and these parts may be readily separated but are held together normally when the spindle is fixed in a rotatable seating position in the side of pulley 18. The disk and stem are rotated jointly in a limited degree by a crank pin 33 on the disk and a rectangular piece 34 having an opening for the pin, piece 34 being slidably confined in a side channel 23 of block 24 so that a reciprocable movement of the block may cause a turning movement of the spindle whenever rack bar 14 is shifted. When the rack bar is held stationary the square block 24 is also held against movement axially of the shaft but is free to rotate around sleeve 25 together with pulley 18 and the fan blades will be held constantly at the working angle fixed by the rack bar setting.

The means for securing each fan blade spindle and its operating parts in the desired working relation in pulley 18, is as follows: Each spindle is removably seated in a bushing 35 in the side of pulley 18 and extends beyond the inner end of the bushing where an annular grooved portion 36 on the spindle may be fitted with a slotted locking blade 37 introduced through the open end of the pulley when cover plate 21 is removed. Blade 37 extends outwardly where its end may be engaged by the inner side of cover plate 21 when the cover plate is fastened to the pulley by screws or bolts, thereby preventing the four blades from being displaced as long as the cover plate is in place, but permitting each blade to be removed when the cover plate is detached. Blade 37 also serves to lock bushing 35 in the wall of the pulley.

A constant locking tension is also applied to each blade by a dished washer 38 of spring metal which is sleeved over the spindle and seated upon the outer flanged end of its bushing 35 beneath a shoulder or enlargement 39 on the bifurcated blade holding part of the spindle, see Fig. 2. Thus in inserting the

spindle in the bushing an inward pressure is required to compress the spring washer before the slotted locking blade can be affixed to the grooved portion of the spindle. The tension obtained in this way locks each blade 37 independently in place, prevents rattling, and takes up wear, while the cover plate 21 locks all of the blades 37 against displacement when the fan is operating. A felt gasket 40 may also be sleeved over the spindle and confined within the dished side of each spring washer 38 to assist the spring washer in preventing the escape of oil from the hollow interior of the bushing and which space may be completely filled with oil for lubricating purposes. Packing 41 may also be confined within the pulley around shaft 6 to prevent leakage of oil at that point. From the foregoing it will be noted that the spindle and each fan blade may be readily detached for repairs or replacement; that the locking of the spindles in place within the pulley serves to hold the crank disks and pieces for each spindle in working place against the channeled operating block; that all the working parts within the pulley operate in a body of lubricating oil or grease; that the spring washers serve to take up wear and effect locking of the spindles and also operate to keep the joints tight to prevent the escape of the lubricant; that the operating lever may be easily attached and set to avoid obstructions at the side of the engine; that the various parts may be easily assembled and disassembled; and that the complete device occupies a small space, and may be readily attached to an automobile engine together with convenient controlling connections extending to the driver's seat.

What I claim is:

1. A revoluble fan body having a set of fan blades provided with spindles, means within said body for turning said spindles, and means including spring tension devices for securing said spindles rotatably upon said body, said spring devices being arranged to exert a tension axially of said spindles.

2. A revoluble fan comprising a pulley having bushings in its side, fan blade spindles rotatably seated within said bushings, means within said pulley adapted to oscillate said spindles, and a separate locking device for each spindle and bushings confined within said pulley.

3. A rotatable fan, comprising a hollow body having removable bushings in its sides, fan blade spindles extending through said bushings, means within said body for oscillating said spindles, locking devices for securing said bushings and spindles jointly against removal from said body, and a closure member for said hollow body covering and holding said locking devices in place.

4. A rotatable fan, comprising a hollow

body having fan blade spindles extending thereinto, means for oscillating said spindles, and separate slotted pieces for locking said spindles rotatably within said body.

5 5. A rotatable fan, comprising a hollow body having fan blade spindles journaled in its walls and formed with annular grooves, means for oscillating said spindles, and separate slotted locking plates for locking said  
10 spindles rotatably within said body, said locking plates being engaged with said body and the grooved portion of said spindles.

6. A rotatable fan, comprising a hollow body having fan blade spindles mounted radially therein, crank members detachably  
15 connected with the inner end of said spindles, a tubular shaft for said body, and means for operating said crank members, including a channeled block, slidable pieces engaging said crank members, a supporting sleeve  
20 for said block, and a bar having a cross pin connected with said sleeve and extending through the sides of said tubular shaft.

7. A rotatable fan, comprising a tubular shaft having slots therein, a rack bar slidably confined within said shaft, a sleeve  
25 mounted upon said shaft, a pin extending through said rack bar and the slots in said shaft and engaging said sleeve, a flat sided block rotatably mounted upon said sleeve  
30 having channels in its flat sides, a hollow fan body having fan blade spindles extending thereinto and provided with flat pieces engaging the flat sides of said block, said pieces having crank pins, and sliding pieces within  
35 the said channels connected to said pins.

8. A rotatable fan, comprising a hollow body having removable spindles radially thereof formed with tongues at their inner  
40 ends, and means for oscillating said spindles, including crank members having slots to removably seat said tongues.

9. A rotatable fan, comprising a hollow body having spindles radially thereof, locking plates engaging said body and spindles,  
45 a removable cover plate at one end of said body engaging said locking plates, and means within said body for oscillating said spindles.

50 10. A rotatable fan, comprising a hollow body, oscillating spindles mounted upon said body, a tubular shaft extending into said body, a rack bar within said shaft, a flanged sleeve on said shaft having a removable collar,  
55 a cross pin connecting said rack bar and sleeve and collar together, and a rotating

block and crank members connecting said sleeve and spindles together.

11. A fan attachment for automobile engines, comprising a bracket affixed to the engine, a rotatable part carried by said bracket  
60 having a tubular shaft mounted in eccentric relation to the axis of said part, a revoluble body carrying oscillatory fan blades, and means within said body for oscillating said  
65 fan blades having controlling means extending through said tubular shaft and outwardly therefrom adjacent said bracket.

12. A fan attachment for automobile engines, comprising a main bracket affixed to  
70 the engine, a tubular shaft extending forwardly and rearwardly of said bracket, a revoluble body having oscillatory fan blades mounted upon the forward part of said shaft, a bracket clamped to the rear part  
75 of said shaft having a lever pivoted thereon, a rack bar within said shaft operably connected with said lever, means within said body connecting said rack bar and the oscillatory fan blades operably together, and  
80 said lever and its supporting bracket being angularly adjustable in respect to said main bracket and the engine.

13. A fan attachment for automobile engines, comprising a tubular shaft and supporting means therefor, a rack bar within  
85 said shaft, a clamp affixed upon one end of said shaft having an arm and a toothed lever pivoted upon said arm in operating engagement with said rack, a revoluble body mounted  
90 upon the opposite end of said shaft having a removable end plate provided with a supporting journal for the outer end of the shaft, oscillatory fan blades having spindles extending through said body, and means  
95 slidably mounted upon said shaft having connection with said rack bar and said spindles for oscillating said spindles.

14. A rotatable fan, for an automobile engine, comprising a revoluble body having  
100 oscillatory fan blades, a supporting shaft for said body, a bracket, affixed to the engine adapted to support said shaft, and means for oscillating said fan blades having an operating connection extending lengthwise of said  
105 engine, said means projecting laterally from said shaft and rotatable about the axis thereof to permit different angular settings of said means relatively to said engine.

In testimony whereof I affix my signature.

CARL F. EHINGER,