



- (51) International Patent Classification:  
H01F 38/14 (2006.01) H02J 5/00 (2016.01)
- (21) International Application Number:  
PCT/CN2016/106225
- (22) International Filing Date:  
17 November 2016 (17.11.2016)
- (25) Filing Language: English
- (26) Publication Language: English
- (30) Priority Data:  
62/256,726 18 November 2015 (18.11.2015) US
- (71) Applicant: THE UNIVERSITY OF HONG KONG [CN/CN]; Pokfulam Road, Hong Kong (CN).
- (72) Inventors: HUI, Shu Yuen, Ron; Flat B, 2nd Floor, Block 29, Greenwood Terrace, 26-28 Sui Wo Road, Shatin, Hong Kong (CN). ZHANG, Cheng; Flat H, 3rd Floor, Block 2, Golden Building, 150 Fuk Wa Street, Sham Shui Po, Kowloon, Hong Kong (CN).
- (74) Agent: CHINA PATENT AGENT (H.K.) LTD.; 22/F., Great Eagle Center, 23 Harbour Road, Wanchai, Hong Kong (CN).

- (81) Designated States (unless otherwise indicated, for every kind of national protection available): AE, AG, AL, AM, AO, AT, AU, AZ, BA, BB, BG, BH, BN, BR, BW, BY, BZ, CA, CH, CL, CN, CO, CR, CU, CZ, DE, DJ, DK, DM, DO, DZ, EC, EE, EG, ES, FI, GB, GD, GE, GH, GM, GT, HN, HR, HU, ID, IL, IN, IR, IS, JP, KE, KG, KN, KP, KR, KW, KZ, LA, LC, LK, LR, LS, LU, LY, MA, MD, ME, MG, MK, MN, MW, MX, MY, MZ, NA, NG, NI, NO, NZ, OM, PA, PE, PG, PH, PL, PT, QA, RO, RS, RU, RW, SA, SC, SD, SE, SG, SK, SL, SM, ST, SV, SY, TH, TJ, TM, TN, TR, TT, TZ, UA, UG, US, UZ, VC, VN, ZA, ZM, ZW.
- (84) Designated States (unless otherwise indicated, for every kind of regional protection available): ARIPO (BW, GH, GM, KE, LR, LS, MW, MZ, NA, RW, SD, SL, ST, SZ, TZ, UG, ZM, ZW), Eurasian (AM, AZ, BY, KG, KZ, RU, TJ, TM), European (AL, AT, BE, BG, CH, CY, CZ, DE, DK, EE, ES, FI, FR, GB, GR, HR, HU, IE, IS, IT, LT, LU, LV, MC, MK, MT, NL, NO, PL, PT, RO, RS, SE, SI, SK, SM, TR), OAPI (BF, BJ, CF, CG, CI, CM, GA, GN, GQ, GW, KM, ML, MR, NE, SN, TD, TG).

Published:  
— with international search report (Art. 21(3))

(54) Title: A WIRELESS POWER TRANSFER SYSTEM

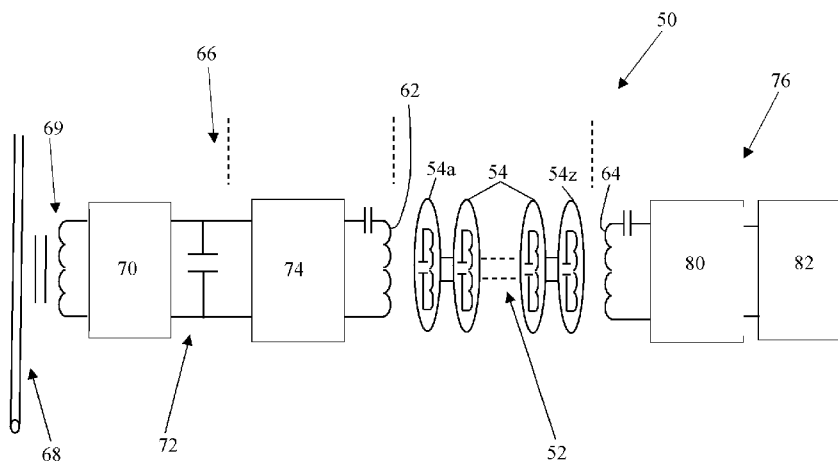

Fig.6

(57) Abstract: Novel and advantageous insulator discs with embedded resonator coils are provided. By linking the insulator discs in a series using an appropriate mechanical mechanism, the insulator discs form an insulator or insulator string for a high power transmission line system. The resonator coils embedded inside the insulator discs therefore form a series of relay resonators that can be used for wireless power transfer through the principle of near-field magnetic coupling and resonance. The insulator string can provide the simultaneous functions of voltage insulation and wireless power transfer over the length of the string. Applications include, but not limited to, wireless power transfer in a high-voltage environment such as that encountered in high-voltage power transmission line systems.

WO 2017/084599 A1

## DESCRIPTION

## A WIRELESS POWER TRANSFER SYSTEM

## 5 CROSS-REFERENCE TO RELATED APPLICATION

This application claims priority to and the benefit of U.S. Provisional Patent Application Serial No. 62/256,726, filed on November 18, 2015, which is incorporated herein by reference in its entirety, including any figures, tables, and drawings.

## 10 FIELD OF THE INVENTION

The invention relates to a wireless power transfer system suitable for high voltage power transmission line systems.

## BACKGROUND

15 The Smart Grid and the Internet of Things have prompted active research in recent years to set up online monitoring systems for power transmission systems. Such monitoring systems are particularly important and critical to some regions such as, for example, China, which has suffered several large-scale blackouts in recent years due to heavy snow storms in central and northern China and typhoons in southern China. The 2008 power blackout in  
20 China resulted in an estimated total financial loss exceeding 100 billion RMB (approx. US\$65 billion). The seriousness of the power blackout problems in China is such that there is a growing body of research in China related to improving online monitoring of power transmission systems using monitoring devices and systems mounted on power transmission system towers.

25 Online monitoring systems for power transmission towers and cables cover a range of monitoring services such as electric parameters (e.g., voltage, current, phase angle, and power), mechanical parameters (e.g., tower structure, cable galloping, ice/snow thickness, and wind-induced mechanical vibration of transmission tower), thermal parameters (e.g., cable temperature), and weather information (e.g., wind speed, temperature and lightning,  
30 and pollution level), as well as anti-theft monitoring.

Some known monitoring systems for high voltage power transmission systems are powered by solar panel units mounted on the power transmission towers. One problem with such a form of power supply is the intermittency of available solar energy, which is

exacerbated during prolonged periods of inclement weather, which can lead to depletion of charge in the solar panel unit's batteries and thus the powering down of the monitoring system.

R. Berthiaume and R. Blais, "Microwave repeater power supply tapped from the overhead ground wire on 735 kV transmission lines," IEEE Trans. Power App. Syst., vol. PAS-99, no. 1, pp. 183–184, Jan./Feb. 1980, discloses a technique in which microwave repeaters are used to transmit power harvested from the high voltage power transmission cables from one point to another.

A. Kurs, A. Karalis, R. Moffatt, J. D. Joannopoulos, P. Fisher, and M. Soljacic, "Wireless power transfer via strongly coupled magnetic resonances," Science, vol. 317, no. 5834, pp. 83-86, Jul. 2007, discloses a mid-range wireless power transfer technique using magnetic resonance. The magnetic resonance wireless power transfer technique disclosed by Kurs adopts the Maximum Power Transfer Principle that has the limitation of poor system efficiency. For any circuit that operates with the Maximum Power Transfer Theorem via impedance matching with the source impedance, there is an inherent limitation that the energy efficiency of the system cannot be higher than 50% For a transmission distance of about 2 meters, the system energy efficiency is at best 15%, as discussed in S.Y.R. Hui, W.X. Zhong and C.K. Lee, "A critical review of recent progress in mid-range wireless power transfer", IEEE Transactions on Power Electronics, Vol. 29, No. 9, September 2014, pp:4500-4511.

Wireless domino-resonator wireless power transfer systems have been disclosed in:

[1] S.Y.R. Hui and W.X. Zhong, "Apparatus and Method for Wireless Power Transfer", Patent application PCT/IB2011/000050, 14 January 2011;

[2] W.X. Zhong, C.K. Lee and S.Y.R. Hui, "General Analysis on the Use of Tesla's Resonators in Domino Forms for Wireless Power Transfer", IEEE Transactions on Industrial Electronics, Vol.60, No.1, January 2013, pp: 261-270;

[3] C.K. Lee, W.X. Zhong and S.Y.R. Hui, "Effects of Magnetic Coupling of Non-adjacent Resonators on Wireless Power Domino-Resonator Systems", IEEE Transactions on Power Electronics, Volume: 27, Issue: 4, 2012, Page(s): 1905 – 1916; and

[4] W.X. Zhong, C.K. Lee and S.Y.R. Hui, "Wireless Power Domino-Resonator Systems with Non-coaxial axes and Circular Structures", IEEE Transactions on Power Electronics Volume: 27, Issue: 11, 2012, Page(s): 4750 – 4762.

The wireless domino-resonator systems in [1] to [4] have been practically proven to provide a highly efficient way to transfer wireless power over a few meters. Unlike the Kurs proposal, the wireless domino-resonator systems adopt the Maximum Energy Efficiency Principle and can achieve an overall system energy efficiency higher than 50%. One  
5 advantage of the wireless domino-resonator systems is that the resonators can be arranged flexibly to guide the wireless power flow rather than being limited to straight-line power transmission.

In view of the increasing demand for powering online monitoring systems for power transmission towers and transmission lines, there is a need for new insulator structures that  
10 can provide (1) high-voltage (HV) insulation and (2) wireless power transfer (WPT) capabilities.

#### BRIEF SUMMARY

In an embodiment, an insulator device comprises: a body formed of an electrically  
15 insulating material, said body defining a cavity; and a resonator coil located within said cavity, said coil being configured for resonant inductive coupling with a similar such coil when placed in the vicinity of the similar such coil.

In another embodiment, an insulator comprises a series of connected insulator devices, a plurality of said series of insulator devices each comprising a body formed of an  
20 electrically insulating material, said body defining a cavity, and a resonator coil located within said cavity, said coil being configured for resonant inductive coupling with a similar such coil when placed in the vicinity of the similar such coil, wherein the plurality of insulator devices having a resonator coil are arranged within the series of devices so as to enable the near field transmission of electrical energy from a first end of the series to a  
25 second end of the series.

In another embodiment, a wireless power transfer system comprises: an insulator having a series of connected insulator devices, a plurality of said series of insulator devices each comprising a body formed of an electrically insulating material, said body defining a  
30 cavity, and a resonator coil located within said cavity, said coil being configured for resonant inductive coupling with a similar such coil when placed in the vicinity of the similar such coil; an energy transmitting coil magnetically coupled to a first resonator coil insulator device of said series of connected insulator devices for wirelessly delivering electrical energy to said first resonator coil insulator device; and an energy receiving coil

magnetically coupled to a last resonator coil insulator device of said series of connected insulator devices for wirelessly receiving electrical energy from said last resonator coil insulator device, wherein the plurality of insulator devices having a resonator coil are arranged within the series of devices so as to enable the near field transmission of electrical energy from a first end of the series to a second end of the series.

In another embodiment, a method of monitoring a power transmission line comprises providing the power transmission line with a monitoring apparatus powered by electrical energy harvested from the powerline and transmitted to the monitoring apparatus using a wireless power transfer system as described herein (e.g., the wireless power transfer system of the previous paragraph).

Other aspects of the invention are in accordance with the appended claims.

The summary of the invention does not necessarily disclose all the features essential for defining the invention; the invention may reside in a sub-combination of the disclosed features.

#### BRIEF DESCRIPTION OF THE DRAWINGS

The foregoing and further features of the present invention will be apparent from the following description of preferred embodiments, which are provided by way of example only in connection with the accompanying figures, of which:

**Figure 1** shows a known straight wireless power domino resonator system;

**Figure 2** shows a known curved wireless power domino resonator system;

**Figure 3** shows a typical insulator for a high voltage power transmission system tower;

**Figures 4a and 4b** show a known toughened glass insulator disc for a high voltage power transmission system tower and an insulator comprising a series of connected insulator discs, respectively;

**Figures 5a and 5b** show schematic cross-sectional diagrams of a known insulator disc for a high voltage power transmission system tower and an insulator comprising a series of connected insulator discs, respectively;

**Figure 6** is a schematic block diagram of a wireless power transfer system in accordance with an embodiment of the subject invention;

**Figure 7** shows an energy harvesting point and an energy receiving point on a high voltage power transmission system tower for a wireless power transfer system in accordance with an embodiment of the subject invention;

**Figures 8a and 8b** show an insulator disc and an insulator comprising a series of connected insulator discs, respectively, in accordance with an embodiment of the subject invention;

**Figure 9** shows part of a flexible insulator comprising a series of insulator discs with a section of each insulator disc removed to show an embedded resonator coil therewithin in accordance with an embodiment of the subject invention; and

**Figure 10** depicts an insulator for a high voltage power transmission tower in accordance with an embodiment of the subject invention.

#### DETAILED DESCRIPTION

The following description is of preferred embodiments by way of example only and without limitation to the combination of features necessary for carrying the invention into effect.

Figure 1 shows a known straight wireless power transfer domino resonator system **10** consistent with the disclosures of [1] to [4] above. The system **10** has a plurality of LC resonator coils **12** arranged on supports **14** in a spaced-apart series in a straight line such that adjacent coils **12** become magnetically coupled to wirelessly transfer electrical energy from a first coil **12a** in the series to the last coil **12z** in the series.

Figure 2 shows a known curved wireless power transfer domino resonator system **20** consistent with the disclosures of [1] to [4] above. The system **20** also has a plurality of LC resonator coils **22** arranged on supports **24** in a spaced apart series, but arranged in a curve to illustrate that it is possible for magnetically coupled adjacent coils **22** to wirelessly transfer electrical energy from a first coil **22a** in the series to the last coil **22z** in the series over a curved pathway.

Figure 3 shows a power transmission line system tower **30** supporting a plurality of high voltage power lines **32** by means of known insulators **34**. The insulator **34** comprises a series of connected insulator discs **36** as better seen in Figures 4a and 4b and Figures 5a and 5b, although these figures merely depict one type of power transmission line system insulator.

Referring to Figure 5a, each insulator disc **36** has a cap **38** defining a ball socket, and a central pin **40** having a ball **42** at an exposed end thereof, the central pin **40** being cemented or otherwise affixed in a cavity of a porcelain or glass body **44** where the insulator body **44** has an insulated head **46**, which separates and insulates the ball socket from the central pin **40**. Referring to Figure 5b, two insulator discs **36** can be arranged in a series by inserting the ball **42** of one disc **36** into the ball socket of an adjacent disc **36**. It will be understood that Figures 3 to 5 are merely illustrative of one form of insulator **34** and that others are known, which employ different connection methods, but share the feature that a string of discs **36** forming an insulator **34** provides an insulator **34** that may not only provide insulation for a high voltage power transmission line from other transmission components including the tower, but act as a mechanical device to support a power transmission line.

Embodiments of the subject invention relate to new structures of insulator discs with embedded resonator coils. By linking the insulator discs in a series using an appropriate mechanical mechanism, the insulator discs form an insulator, insulator string, or insulator rod for a high power transmission line system. The resonator coils embedded inside the insulator discs therefore form a series of relay resonators that can be used for wireless power transfer through the principle of near-field magnetic coupling and resonance. Such an insulator string can provide the simultaneous functions of voltage insulation and wireless power transfer over the length of the string or rod. Applications of embodiments of the subject invention are particularly suitable for, but not limited to, wireless power transfer in a high-voltage environment, such as encountered in high-voltage power transmission line systems.

Figure 6 provides a schematic block diagram of a wireless power transfer system **50** according to an embodiment of the subject invention. The system **50** comprises an insulator **52** formed from a series of connected insulator devices, e.g., insulator discs **54**. A plurality of said series of insulator devices **54** may, as shown in Figure 8a, each comprise a body **56** formed of an electrically insulating material, said body **56** defining a cavity **58**. A resonator coil **60** is located within the cavity **58** with said coil **60** being configured for resonant inductive coupling with a similar such coil when placed in the vicinity of the similar such coil. The plurality of insulator devices **54** having an embedded resonator coil **60** may comprise a subset of the series of insulator devices such that not all insulator devices or

discs in a series include a resonator coil **60**. However, in many embodiments, all of the insulator discs **54** are provided with a resonator coil **60**.

The wireless power transfer system **50** can include an energy transmitting coil **62** magnetically coupled to a first resonator coil insulator device **54a** of said series of connected insulator devices for wirelessly delivering electrical energy to said first resonator coil insulator device **54a**. Also provided is an energy receiving coil **64** magnetically coupled to a last resonator coil insulator device **54z** of said series of connected insulator devices for wirelessly receiving electrical energy from said last resonator coil insulator device **54z**. The plurality of insulator devices **54** having a resonator coil **60** are arranged within the series of devices so as to enable the near field transmission of electrical energy from a first end of the series to a second end of the series and vice-versa in some systems, i.e., the system **10** could be configured to be bi-directional.

The energy transmitting resonator coil **62** comprises a part of an energy harvesting circuit **66** that is configured to wirelessly harvest energy from a high voltage power transmission line **68** using a transformer (or an magnetically coupled device) **69**. The energy harvesting circuit **66** may in some embodiments comprise an alternating current (AC) to direct current (DC) power converter **70** for charging one or more batteries or capacitors **72** and for feeding a DC to AC inverter **74**. The DC to AC inverter **74** can be configured to provide a high frequency AC signal for driving the energy transmitting coil **62**. The mains frequency of 50 Hertz (Hz) may be up-converted by the energy harvesting circuit **66** to a frequency of typically higher than 20,000 Hz for driving the energy transmitting resonator coil **62**.

The energy receiving resonator coil **64** comprises part of an energy receiver circuit **76**, which may include in some embodiments a high frequency AC to DC (or AC to AC) converter **80** for providing a supply voltage or current at levels suitable for powering monitoring apparatuses **82**, which are configured to provide monitoring services such as electric parameters (e.g., voltage, current, phase angle, and power), mechanical parameters (e.g., tower structure, cable galloping, ice/snow thickness, and wind-induced mechanical vibration of transmission tower), thermal parameters (e.g., cable temperature), and/or weather information (e.g., wind speed, temperature and lightning, and pollution level), as well as anti-theft monitoring.

The series of connected insulator devices **54** comprising the insulator **52** define a wireless power transfer domino-resonator system, which is configured to direct the flow of

electrical energy from the first end of the series to the second end of the series by means of near field transmission of electrical energy from one end of the series to the other end of the series.

5 It will be understood that it is preferred that the insulator **52** is configured as an insulator for a high voltage power transmission system, but this is not an essential requirement of embodiments of the subject invention. In some embodiments, the insulator **52** is configured to support a power transmission cable. In many embodiments, the structures of the insulator **52** and the insulator discs **54** are changed as explained in more detail below, such that the insulator **52** may not be employed as a transmission line support  
10 device.

In some embodiments, the resonator coils **60** embedded inside the plurality of insulator devices **54** are identical for optimal transmission of electrical energy from the first end of the series to the second end of the series, and the plurality of insulator devices **54** is arranged with a distance between adjacent resonator coil insulator devices such that a  
15 mutual coupling factor between adjacent devices is sufficiently large for optimal or efficient transmission of electrical energy from the first end of the series to the second end of the series, preferably with said distance being similar or less than a size of the diameter of an embedded resonator coil **60**. The distance between adjacent resonator coil insulator devices is preferably the same or substantially the same. The distance between the energy  
20 transmitting coil **62** and first resonator coil insulator device **54a** of said series of connected insulator devices may be smaller than the distance between adjacent resonator coil insulator devices **54**. Similarly, the distance between the energy receiving coil **64** and last resonator coil insulator device **54z** of said series of connected insulator devices may be smaller than the distance between adjacent resonator coil insulator devices **54**.

25 Referring to Figure 7, an application of the present invention can be further illustrated by reference to an example of a standard power transmission system tower. The

magnetic field generated by the transmission cable (marked as ① in Figure 7) can be

“continuously” harvested with a transformer and a power converter comprising the energy harvesting circuit **68** of Figure 6. The harvested energy can be stored in one or more

supercapacitors and/or rechargeable batteries (72 in Figure 6). Because energy can be harvested from the power cable continuously without any time constraint (such as daytime only for solar panels), the storage capacity of the supercapacitor and/or battery 72 is expected to be much smaller than that for a solar power system. As the online monitoring

5 system has to be mounted on the power transmission system tower (marked as ② in Fig. 7),

which is earthed, there is a considerable transmission distance between the energy-harvesting point ① and the energy-receiving point ②.

According to IEC 60137 International Standard, Fifth edition, 2003, “Insulated bushings for alternating voltages above 1000V, the creepage distance depends on the  
10 voltage and the air pollution conditions as listed in Table 1 below:

Table 1. IEC 60137 Standard on Creepage Distance for Voltage > 1000V

Condition	Creepage
Normal	16 mm/kV
Medium pollution	20 mm/kV
Heavy pollution	25 mm/kV
Very Heavy Pollution	31 mm/kV

For a medium polluted condition and a transmission line voltage of 110 kiloVolts  
15 (kV), the creepage distance for wireless power transmission has to be at least 2.2 meters (m). Referring again to Figure 3, which shows an example of a known insulator string holding the high voltage transmission line to the transmission tower, for transmission distances of this magnitude, traditional wireless power transmission techniques cannot achieve high efficiency (typically < 15%) because such efficiency is inversely proportional to the  
20 transmission distance.

Embodiments of the subject invention address this problem through use of the disclosed novel insulator string or rod **52**.

Referring again to Figures 8a and 8b, the resonator can comprise a coil connected in parallel with a resonator capacitor to form an inductive-capacitor resonator tank whereby a resonance frequency of the resonator coil is determined by the values of the inductor and the capacitor.

The electrically insulating material preferably comprises a material rated for use in high voltage power transmission systems.

The insulator or insulator string **52** may connect the insulator devices or discs **56** by a rigid insulator shaft as shown in Figure 8b or by a flexible insulator shaft as shown in Figure 9.

The transmitter resonator coil **62** can be arranged in such a way that it is placed close to and magnetically coupled to the first resonator coil **54a** in the series of insulator discs **54** on the transmitter side. Similarly, the last resonator coil **54z** in the series of insulator discs **54** of the insulator rod or string can be placed close to the receiver resonator coil **64** for close magnetic coupling. The operation of the proposed insulator rod/string is based on the wireless domino-resonator systems of Figures 1 and 2. Based on the short-range magnetic resonance technique of [1] to [4], it has been shown that this approach is a good compromise of high energy efficiency and transmission distance.

It is important to note that the disclosed embodiments of the high voltage insulators (rods or strings) may have different functions when compared with traditional high voltage insulators. Traditional ones, such as those shown in Figures 3 to 5 are designed to provide the simultaneous functions of (i) mechanical support and (ii) high voltage insulator. The novel ones disclosed herein offer the simultaneous functions of (i) wireless power transmission over the creepage distance and (ii) high voltage insulation.

As described above, Figures 5a and 5b show the typical structure of a stackable insulator disc and its stacked-up structure, respectively. Because mechanical support is not a key function of the invention, the metallic pin and ball structures used for stacking up the discs in the traditional high voltage insulator rods can be replaced by non-metallic insulator materials.

In embodiments of the subject invention, a first insulator disc structure (Figure 8) can be similar to the traditional one as shown in Figure 5. It can have a stackable structure like the traditional one, except that the metallic pin and ball are replaced with electrical

insulating materials. This is best seen in Figure 8a. When stacked up in series (Figure 8b), these stackable discs form an insulator rod with wireless power transfer capability. The second disc structure for the invention is shown in Figure 9 and has a through-hole in its center for receiving a flexible shaft **90**. The flexible shaft can be made of flexible insulating materials such as cross-linked polyethylene (XLPE or PEX) and/or polyvinyl chloride (PVC). The insulator discs **54** with embedded LC resonators can be mounted along this flexible insulating shaft. To facilitate a standard approach, the distance between adjacent insulator discs should preferably be the same (or substantially the same) as shown in Figure 10. However, it is possible to optimize the power flow if the distance between the last two discs at each end of the insulator string is slightly different from the separation distance of the discs in the central portion of the string.

The insulator material for the discs can be of different types suitable for high voltage applications. Non-limiting examples are toughened glass, glazed porcelain, and polymer. In embodiments of the subject invention, while the series-connected insulator discs provide a high-voltage insulator, the series of coil-resonators provide a wireless power transfer path because these coil-resonators behave like a series of relay coil-resonators as in [1] to [4].

In general, embodiments of the subject invention relate to new structures of insulator discs with embedded resonator coils. By linking the insulator discs in a series using an appropriate mechanical mechanism, the insulator discs form an insulator or insulator string for a high power transmission line system. The resonator coils embedded inside the insulator discs therefore form a series of relay resonators that can be used for wireless power transfer through the principle of near-field magnetic coupling and resonance. Such an insulator string can provide the simultaneous functions of voltage insulator and wireless power transfer over the length of the string. Applications of embodiments of the subject invention are particularly suitable for, but not limited to, wireless power transfer in a high-voltage environment, such as encountered in high-voltage power transmission line systems.

Reference in this specification to “one embodiment” or “an embodiment” means that a particular feature, structure, or characteristic described in connection with the embodiment is included in at least one embodiment of the invention. The appearances of the phrase “in one embodiment” or “in an embodiment” in various places in the specification are not necessarily all referring to the same embodiment, nor are separate or alternative embodiments mutually exclusive of other embodiments. Moreover, various features are described which may be exhibited by some embodiments and not by others. Similarly,

various requirements are described that may be requirements for some embodiments but not other embodiments.

It should be understood that the examples and embodiments described herein are for illustrative purposes only and that various modifications or changes in light thereof will be suggested to persons skilled in the art and are to be included within the spirit and purview of this application.

All patents, patent applications, provisional applications, and publications referred to or cited herein (including those in the "References" section) are incorporated by reference in their entirety, including all figures and tables, to the extent they are not inconsistent with the explicit teachings of this specification.

Moreover, all statements herein reciting principles, aspects, and embodiments of the invention, as well as specific examples thereof, are intended to encompass both structural and functional equivalents thereof. Additionally, it is intended that such equivalents include both currently known equivalents as well as equivalents developed in the future, i.e., any elements developed that perform the same function, regardless of structure.

In the claims hereof, any element expressed as a means for performing a specified function is intended to encompass any way of performing that function including, for example, a) a combination of circuit elements that performs that function or b) software in any form, including, therefore, firmware, microcode or the like, combined with appropriate circuitry for executing that software to perform the function. The invention as defined by such claims resides in the fact that the functionalities provided by the various recited means are combined and brought together in the manner which the claims call for. It is thus regarded that any means that can provide those functionalities are equivalent to those shown herein.

#### REFERENCES

[1] S.Y.R. Hui and W.X. Zhong, "Apparatus and Method for Wireless Power Transfer", Patent application PCT/IB2011/000050, 14 January 2011;

[2] W.X. Zhong, C.K. Lee and S.Y.R. Hui, "General Analysis on the Use of Tesla's Resonators in Domino Forms for Wireless Power Transfer", IEEE Transactions on Industrial Electronics, Vol.60, No.1, January 2013, pp: 261-270;

[3] C.K. Lee, W.X. Zhong and S.Y.R. Hui, "Effects of Magnetic Coupling of Non-adjacent Resonators on Wireless Power Domino-Resonator Systems", IEEE Transactions on Power Electronics, Volume: 27, Issue: 4, 2012, Page(s): 1905 – 1916; and

[4] W.X. Zhong, C.K. Lee and S.Y.R. Hui, "Wireless Power Domino-Resonator Systems with Non-coaxial axes and Circular Structures", IEEE Transactions on Power Electronics Volume: 27 , Issue: 11, 2012 , Page(s): 4750 – 4762.

5 [5] R. Berthiaume and R. Blais, "Microwave repeater power supply tapped from the overhead ground wire on 735 kV transmission lines," IEEE Trans. Power App. Syst., vol. PAS-99, no. 1, pp. 183–184, Jan./Feb. 1980.

[6] A. Kurs, A. Karalis, R. Moffatt, J. D. Joannopoulos, P. Fisher, and M. Soljacic, "Wireless power transfer via strongly coupled magnetic resonances," Science, vol. 317, no. 5834, pp. 83-86, Jul. 2007.

10 [7] S.Y.R. Hui, W.X. Zhong and C.K. Lee, "A critical review of recent progress in mid-range wireless power transfer", IEEE Transactions on Power Electronics, Vol. 29, No. 9, September 2014, pp:4500-4511.

## CLAIMS

What is claimed is:

1. An insulator device, comprising:  
a body formed of an electrically insulating material and defining a cavity; and  
a resonator coil located within the cavity and configured for resonator inductive coupling with a similar such coil when placed in the vicinity of the similar such coil.
2. The insulator device of claim 1, wherein the resonator coil comprises a coil connected in parallel with a resonator capacitor to form an inductive-capacitor resonator tank such that a resonance frequency of the resonator coil is determined by the inductance of the inductive-capacitor resonator tank and the capacitance of the inductive-capacitor resonator tank.
3. The insulator device of claim 1, wherein the electrically insulating material comprises a material rated for use in high voltage power transmission systems.
4. The insulator device of claim 1, wherein the insulator device comprises a component for forming a string insulator comprising a series of connected insulator devices.
5. The insulator device of claim 1, wherein the cavity of the body of the insulator device is a sealed cavity.
6. The insulator device of claim 1, wherein the body of the insulator device has means for connecting the insulator device to a support rod.
7. The insulator device of claim 1, wherein the body of the insulator device has means provided on top and bottom surfaces thereof for connecting the insulator device respectively to two adjacent such devices.

8. The insulator device of claim 1, wherein the insulator device is configured for a high voltage power transmission system application.

9. The insulator device of claim 1, wherein ferromagnetic material is included in the center the resonator coil so that the ferromagnetic material behaves like a magnetic core in the resonator coil.

10. An insulator, comprising:

a series of connected insulator devices, a plurality of which each comprises a body formed of an electrically insulating material and defining a cavity, and a resonator coil located within the cavity and configured for resonator inductive coupling with a similar such coil when placed in the vicinity of the similar such coil;

wherein the plurality of insulator devices having a resonator coil are arranged within the series of connected insulator devices so as to enable the near field transmission of electrical energy from a first end of the series to a second end of the series.

11. The insulator of claim 10, wherein the plurality of insulator devices each comprising a body and a resonator coil comprises all of the insulator devices of the series of connected insulator devices.

12. The insulator of claim 10, wherein the series of connected insulator devices comprise a wireless power transfer domino-resonator system to direct the flow of electrical energy from the first end of the series to the second end of the series.

13. The insulator of claim 10, wherein the plurality of insulator devices having a resonator coil are arranged within the series of devices so as to enable the near field transmission of electrical energy from the second end of the series to the first end of the series.

14. The insulator of claim 10, wherein the insulator is configured as an insulator for a high voltage power transmission system.

15. The insulator of claim 14, wherein the insulator is configured to support a power transmission cable.

16. The insulator of claim 10, wherein the resonator coils embedded inside the plurality of insulator devices are identical for optimal transmission of electrical energy from the first end of the series to the second end of the series.

17. The insulator of claim 10, wherein a distance between adjacent resonator coil insulator devices is less than the diameter of an embedded resonator coil such that a mutual coupling factor between adjacent devices is large enough for efficient transmission of electrical energy from the first end of the series to the second end of the series.

18. The insulator of claim 10, wherein ferromagnetic material is included in the center the resonator coil so that the ferromagnetic material behaves like a magnetic core in the resonator coil.

19. A wireless power transfer system, comprising:

an insulator comprising a series of connected insulator devices, a plurality of which each comprises a body formed of an electrically insulating material and defining a cavity, and a resonator coil located within the cavity and configured for resonator inductive coupling with a similar such coil when placed in the vicinity of the similar such coil;

an energy transmitting coil magnetically coupled to a first resonator coil insulator device of the series of connected insulator devices for wirelessly delivering electrical energy to the first resonator coil insulator device; and

an energy receiving coil magnetically coupled to a last resonator coil insulator device of the series of connected insulator devices for wirelessly receiving electrical energy from the last resonator coil insulator device,

wherein the plurality of insulator devices of the series having a resonator coil are arranged within the series of devices so as to enable the near field transmission of electrical energy from a first end of the series to a second end of the series.

20. The wireless power transfer system of claim 19, wherein the energy transmitting coil comprises part of an energy harvesting circuit that is configured to wirelessly harvest energy from a high voltage power transmission line.

21. The wireless power transfer system of claim 20, wherein the energy harvesting circuit is configured to convert harvested electrical energy into a high frequency AC signal for driving the energy transmitting coil.

22. The wireless power transfer system of claim 19, wherein the energy receiving coil comprises part of a circuit configured to convert a received high frequency AC signal into a voltage or current output suitable for powering one or more power transmission system monitoring apparatuses.

23. The wireless power transfer system of claim 19, wherein ferromagnetic material is included in the center the resonator coil so that the ferromagnetic material behaves like a magnetic core in the resonator coil.

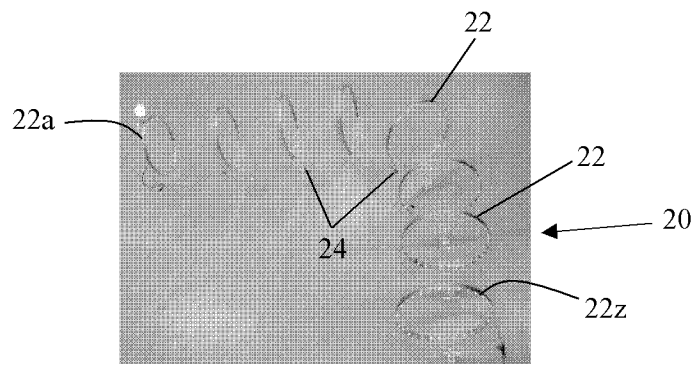
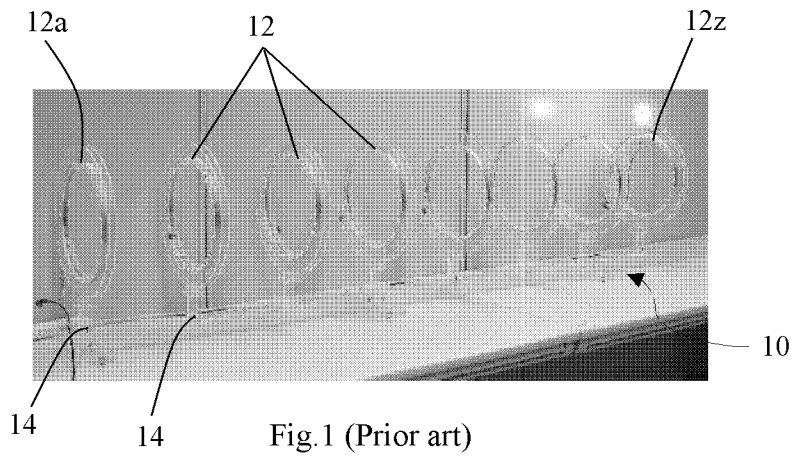

Fig.2 (Prior art)

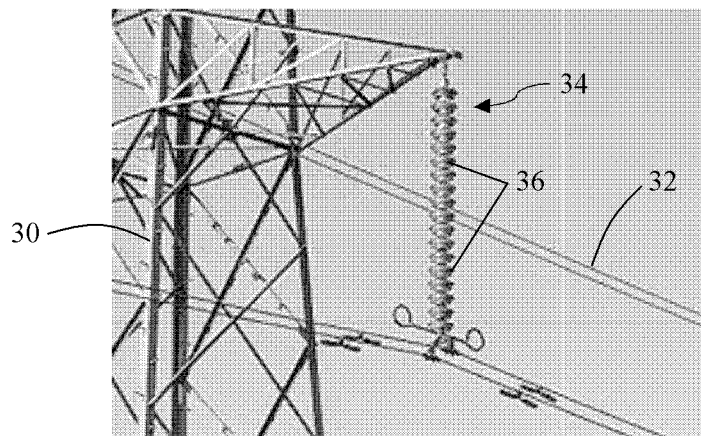

Fig.3 (Prior art)

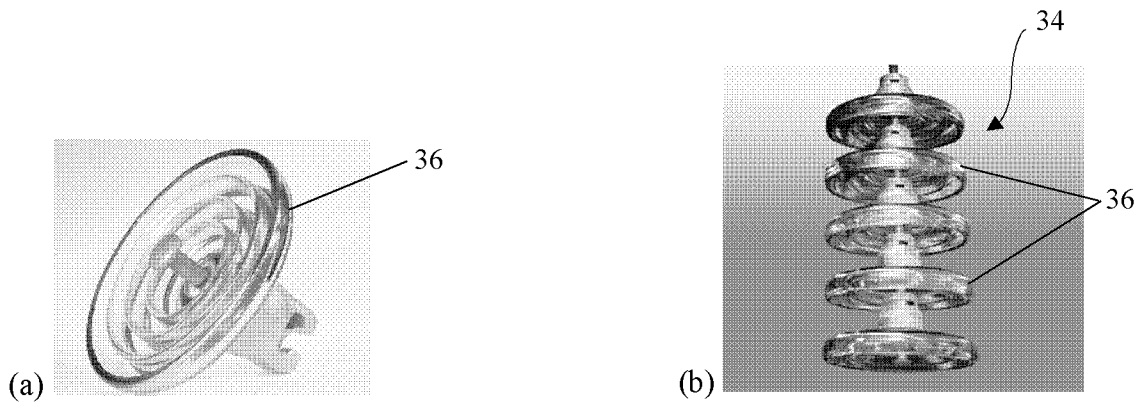

Fig.4 (Prior art)

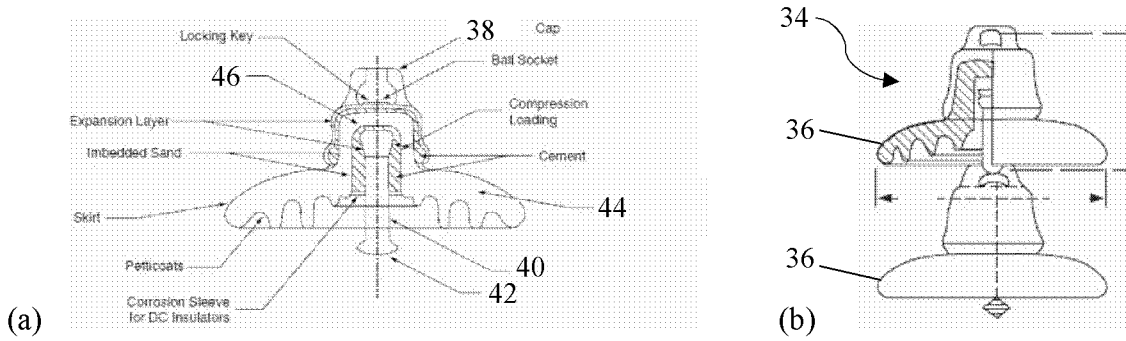

Fig.5 (Prior art)

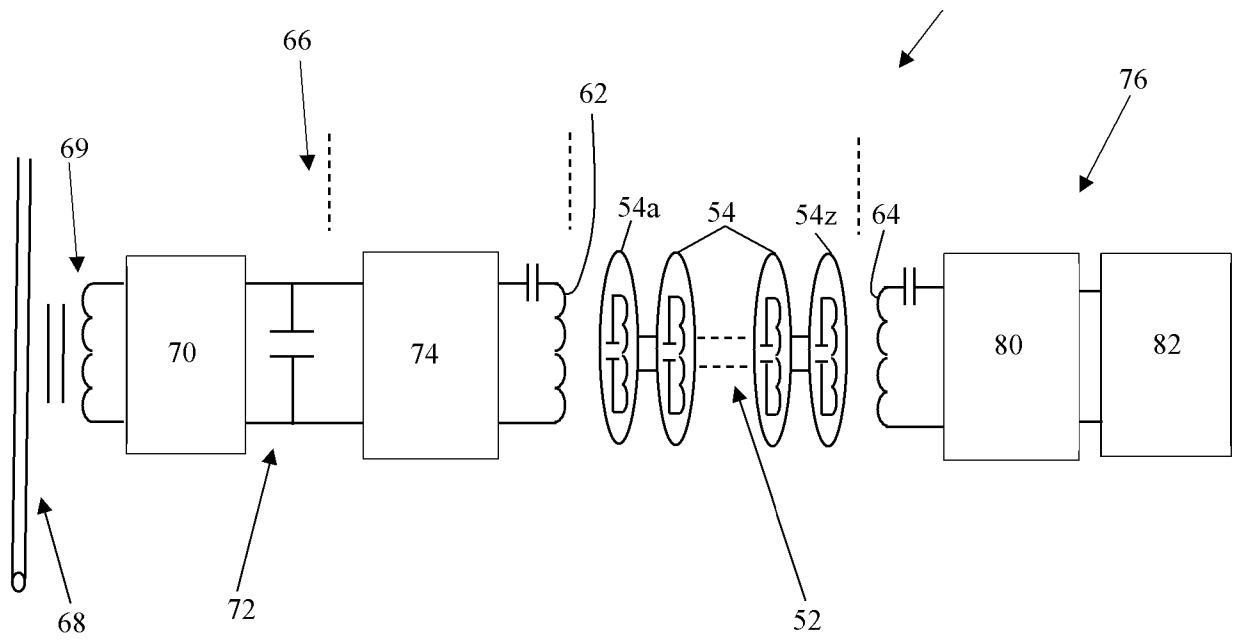

Fig.6

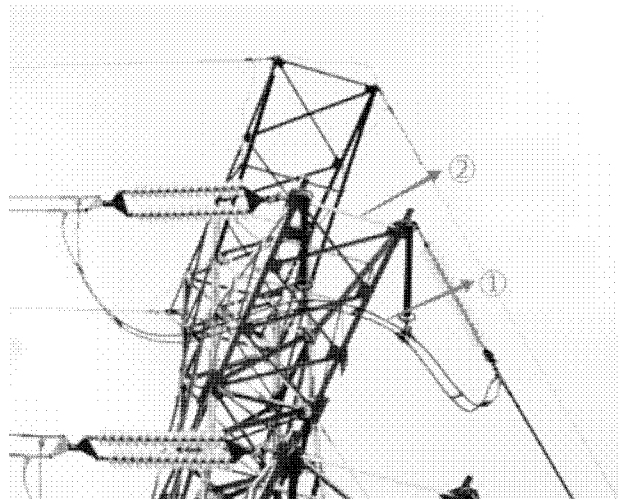

Fig.7

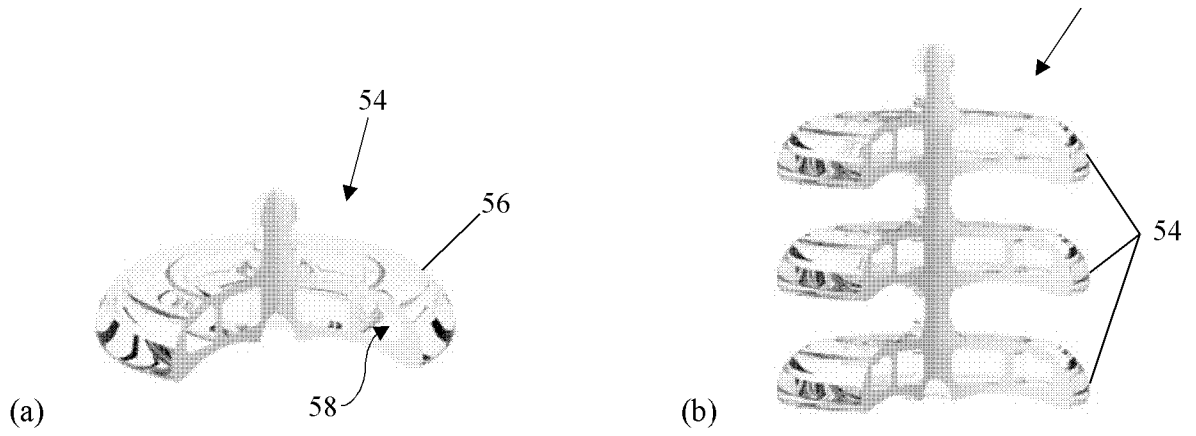

Fig.8

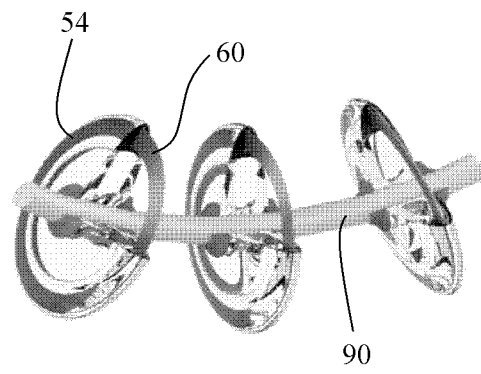

Fig.9

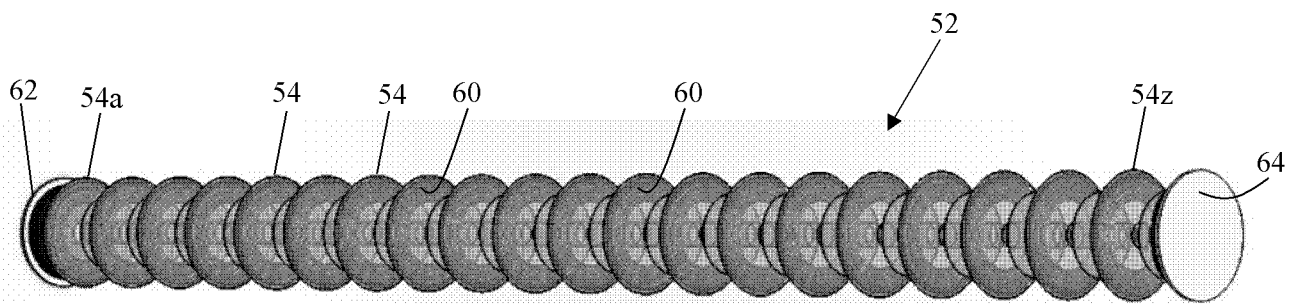

Fig.10

## INTERNATIONAL SEARCH REPORT

International application No.

PCT/CN2016/106225

**A. CLASSIFICATION OF SUBJECT MATTER**

H01F 38/14(2006.01)i; H02J 5/00(2016.01)i

According to International Patent Classification (IPC) or to both national classification and IPC

**B. FIELDS SEARCHED**

Minimum documentation searched (classification system followed by classification symbols)

H01F H02J

Documentation searched other than minimum documentation to the extent that such documents are included in the fields searched

Electronic data base consulted during the international search (name of data base and, where practicable, search terms used)

CNPAT, CNKI, WPI, EPODOC: wireless power energy transfer transmi+ insulat+ resonat+ coil cavity hous+ disc receiv+ optical tank inductive capacitor

**C. DOCUMENTS CONSIDERED TO BE RELEVANT**

Category*	Citation of document, with indication, where appropriate, of the relevant passages	Relevant to claim No.
X	CN 104578439 A (DELTA ELECTRONICS SHANGHAI CO., LTD.) 29 April 2015 (2015-04-29) description paragraphs [0002]-[0005], [0031]-[0041], figures 2-6	1-23
A	CN 103443883 A (CITY UNIVERSITY OF HONG KONG) 11 December 2013 (2013-12-11) the whole document	1-23
A	US 2011101788 A1 (UNIVERCITY OF PITTSBURGH-OF THE COMMONWEALTH SYSTEM OF HIGHER EDUCATION) 05 May 2011 (2011-05-05) the whole document	1-23
A	US 2015228402 A1 (THE UNIVERSITY OF HONG KONG) 13 August 2015 (2015-08-13) the whole document	1-23

 Further documents are listed in the continuation of Box C. See patent family annex.

\* Special categories of cited documents:

"A" document defining the general state of the art which is not considered to be of particular relevance

"E" earlier application or patent but published on or after the international filing date

"L" document which may throw doubts on priority claim(s) or which is cited to establish the publication date of another citation or other special reason (as specified)

"O" document referring to an oral disclosure, use, exhibition or other means

"P" document published prior to the international filing date but later than the priority date claimed

"T" later document published after the international filing date or priority date and not in conflict with the application but cited to understand the principle or theory underlying the invention

"X" document of particular relevance; the claimed invention cannot be considered novel or cannot be considered to involve an inventive step when the document is taken alone

"Y" document of particular relevance; the claimed invention cannot be considered to involve an inventive step when the document is combined with one or more other such documents, such combination being obvious to a person skilled in the art

"&amp;" document member of the same patent family

Date of the actual completion of the international search

16 January 2017

Date of mailing of the international search report

26 January 2017

Name and mailing address of the ISA/CN

STATE INTELLECTUAL PROPERTY OFFICE OF THE  
P.R.CHINA  
6, Xitucheng Rd., Jimen Bridge, Haidian District, Beijing  
100088  
China

Authorized officer

FENG,Nan

Facsimile No. (86-10)62019451

Telephone No. (86-10)61648273

**INTERNATIONAL SEARCH REPORT**  
**Information on patent family members**

International application No.

**PCT/CN2016/106225**

Patent document cited in search report			Publication date (day/month/year)	Patent family member(s)			Publication date (day/month/year)
CN	104578439	A	29 April 2015	TW	201517455	A	01 May 2015
				US	2015108945	A1	23 April 2015
CN	103443883	A	11 December 2013	US	2014028112	A1	30 January 2014
				WO	2012095682	A1	19 July 2012
US	2011101788	A1	05 May 2011	US	2014062212	A1	06 March 2014
US	2015228402	A1	13 August 2015	WO	2015120672	A1	20 August 2015
				EP	3105835	A1	21 December 2016