

G. F. EBERHARD.

BUCKLES.

No. 186,329.

Patented Jan. 16, 1877.

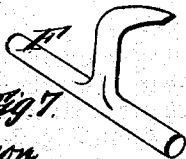
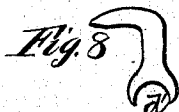
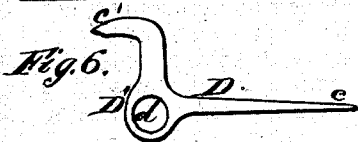
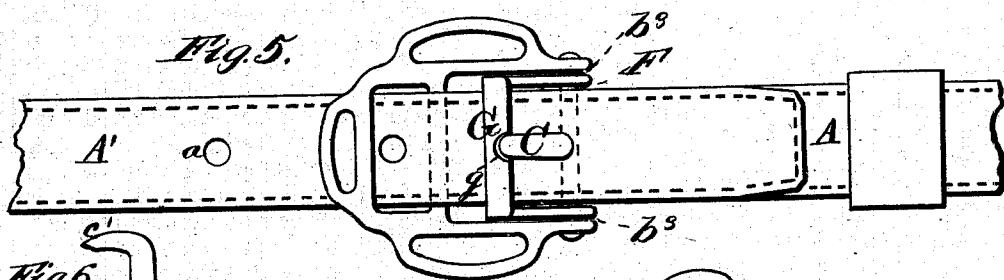
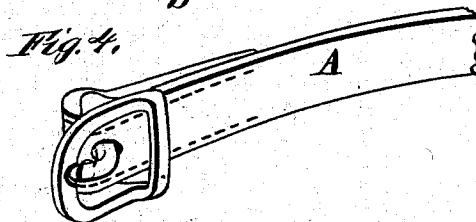
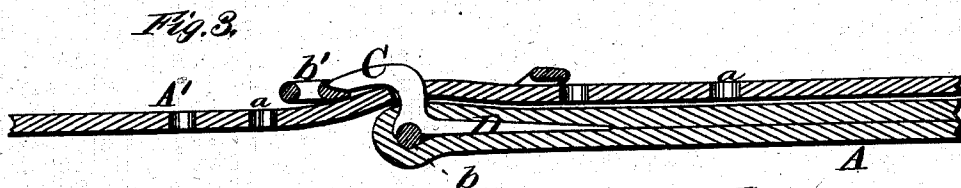
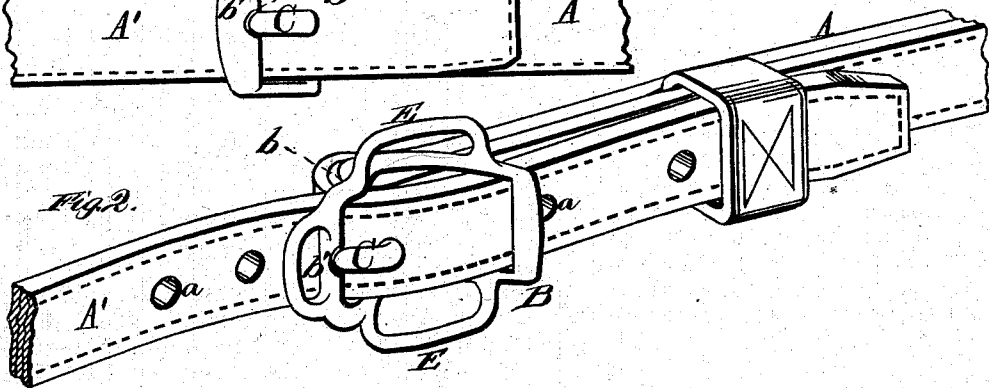
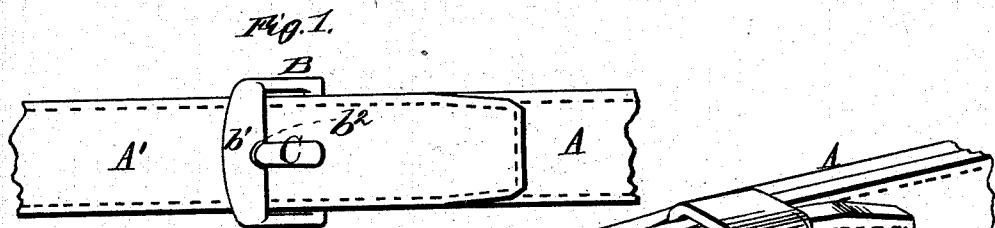

Fig. 9, George F. Eberhard.
c Gilmore, Smith & Co.
ATTORNEYS.

WITNESSES

Robert Everett, Fig. 7.
Eug. W. Johnson.

INVENTOR.

UNITED STATES PATENT OFFICE.

GEORGE F. EBERHARD, OF PITTSBURG, PENNSYLVANIA, ASSIGNOR TO
EBERHARD MANUFACTURING COMPANY, OF SAME PLACE.

IMPROVEMENT IN BUCKLES.

Specification forming part of Letters Patent No. 186,329, dated January 16, 1877; application filed
December 2, 1876.

To all whom it may concern:

Be it known that I, GEORGE F. EBERHARD, of Pittsburg, in the county of Allegheny and State of Pennsylvania, have invented a new and valuable Improvement in Buckles; and I do hereby declare that the following is a full, clear, and exact description of the construction and operation of the same, reference being had to the annexed drawings, making a part of this specification, and to the letters and figures of reference marked thereon.

Figure 1 of the drawings is a representation of a side view of my buckle. Fig. 2 is a perspective view thereof, and Fig. 3 is a horizontal sectional view of the same. Fig. 4 is a perspective view of another style of my buckle, and Fig. 5 is a side view of another style thereof. Figs. 6, 7, 8, and 9 are detail views.

The nature of this invention consists in constructing buckle-tongues in the form of a raised bent wedge or bent tapering bar, with a rearward shank or tail, whereby the said tongue may be operated to release the strap-trace, or other leather confined thereby. It also consists in applying to the raised angular buckle-tongue a pivoted bail, which receives the end or point of said tongue, and relieves the same of strain. It also consists in the combination of the parts, as will be hereinafter more fully set forth.

In the annexed drawings, A A' designate the ends of one or more leathern straps, bands, or traces, secured together by means of the buckle B and bent tongue C. End A is secured to the rear cross-bar *b* of said buckle by folding over the same and sewing, in the usual manner, or by any equivalent method. End A' is provided with the usual perforations *a*, through which passes the tongue C, to complete the attachment.

Fig. 1 shows a simple form of buckle B, provided with a tongue, constructed as more fully shown in Fig. 6. Said tongue is tapering in form, ending in a point, *c*. It is also raised above the buckle, and then extends forward at *c'*, almost at right angles to the upright or raised part. The effect of giving to the said tongue this raised or bent shape is to enable strap or band A' to lie nearly flat when

buckled, without the perforations *a a* being elongated, which weakens the strap. Thus I avoid the unnecessary crumpling and wear of the leather, or the weakening of it by making the holes *a* unnecessarily large, one of which results would ensue if a different form of tongue were used. This construction also relieves the front cross-bar *b'* of the buckle B from direct strain, such strain being applied first to the upright part of the tongue C; but said bent tongue is braced by said front cross-bar *b'*, which is provided with a small recess, *b²*, to receive the point of said tongue C. Said tongue is provided with a tail or shank, D, made in one piece therewith, or otherwise rigidly attached thereto, and adapted to facilitate the removing of said tongue from said perforations *a a*, thereby freeing strap end A' from the other end A. At the angle formed by the junction of said shank or tail D with said tongue C, said tongue is provided on its under side with an enlargement, D', which is perforated at *d* to receive the rear cross-bar *b* of buckle B, on which cross-bar the said tongue is pivoted.

Fig. 2 shows the application of a similar tongue, C, to a trace-buckle, provided with side loops E E, and Fig. 3 shows a longitudinal section of the same. In this case the enlargement D', instead of being perforated, is semicircularly recessed on its under side at *d'*. In other respects the arrangement and construction of the devices are the same, (excepting the shape of the buckle,) and the various parts thereof are similarly lettered in both cases. The shank D rests in all cases between the folds of strap end A, and, when depressed by the thumb, readily disengages the said bent or hooked tongue. The last-described modification of said tongue is shown in detail in Fig. 9.

Fig. 4 shows the application of my angular tongue C to an ordinary buckle, having a central cross-bar below the loop.

Fig. 5 shows a trace-buckle nearly similar to that shown in Fig. 2, but differing therefrom in having no rear cross-bar. Its angular tongue C is made in one piece, with a pivot-bar, F, (shown more distinctly in Fig. 7,) which bar is pivoted in the perforated rear

ends b^3 b^3 of said buckle. Said pivot-bar takes the place of the ordinary rear cross-bar. G designates a bail pivoted upon said pivot-bar F, and provided with a recess, g , for the reception of the point of said angular tongue C. The office of said bail is to relieve said tongue of a part of the strain of the trace by bracing said tongue.

Fig. 8 shows my angular tongue C without either the shank D or pivot-bar F, and having semicircular recess d' for pivoting, as before described.

The bent tongue, hereinbefore described, may be applied to any form of buckle in use, and employed for securing other substances beside leather; also, any one of the modifications of said tongue, shown and described herein, may be substituted for any other modification thereof.

Various other changes may be made without departing from the spirit of my invention.

The said angular tongue C may be cast in the form shown, or it may be formed out of wrought-iron; but in any case it forms a

strong angular post or bar, capable of enduring considerable strain.

What I claim as new, and desire to secure by Letters Patent, is—

1. In a buckle, the raised angular buckle-tongue C, provided with a lever-shank or tail, D, substantially as and for the purpose set forth.

2. The combination, with the raised angular buckle-tongue C, of the bail G, recessed at g , for the purpose of bracing the tongue, and relieving it from strain, substantially as described.

3. The combination of a buckle-frame, a raised angular tapering tongue, and a bail for bracing said tongue, substantially as set forth.

In testimony that I claim the above I have hereunto subscribed my name in the presence of two witnesses.

GEO. F. EBERHARD.

Witnesses:

E. CRAWFORD,
WM. S. MARKS.