

B. C. & F. W. HALL,
AUTOMATIC FIRE ALARM.
APPLICATION FILED JAN. 12, 1907.

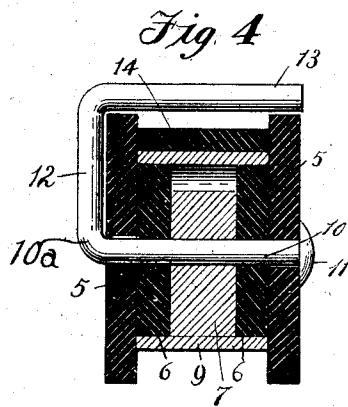
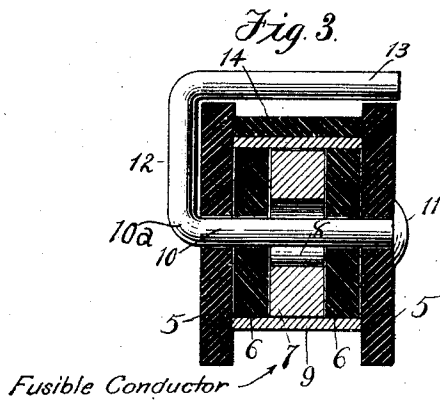
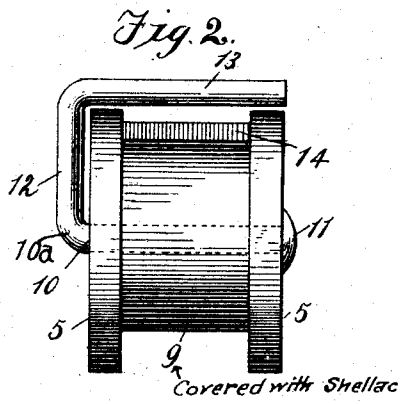
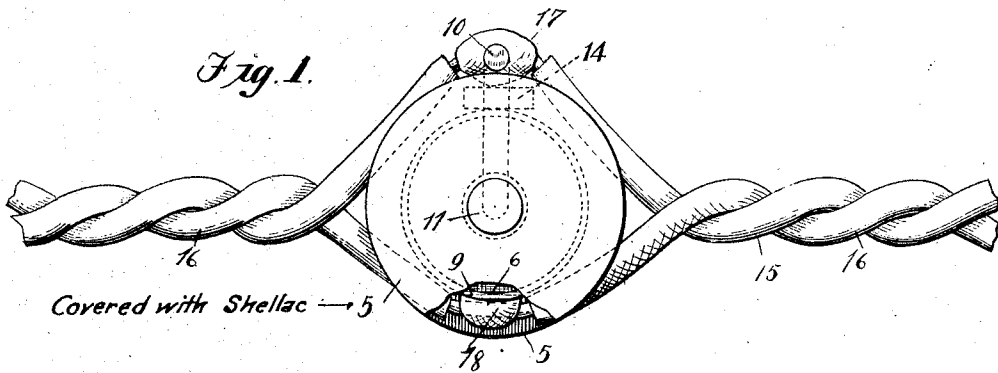

Witnesses:
C. F. Bassett
Matthew J. Marty

Inventors:
Bruce C. Hall
Floyd W. Hall.
By *Fredrick Benjamin*
Atty.

UNITED STATES PATENT OFFICE.

BRUCE C. HALL AND FLOYD W. HALL, OF ELMWOOD, ILLINOIS.

AUTOMATIC FIRE-ALARM.

No. 875,810.

Specification of Letters Patent.

Patented Jan. 7, 1908.

Application filed January 12, 1907. Serial No. 352,062.

To all whom it may concern:

Be it known that we, BRUCE C. HALL and FLOYD W. HALL, citizens of the United States, residing at Elmwood, in the county of Peoria and State of Illinois, have invented certain new and useful Improvements in Automatic Fire-Alarms, of which the following is a specification:

This invention relates to improvements in automatic fire alarm apparatus of that class in which fusible elements are used to close an electric circuit whereby suitable alarm devices are operated.

The particular object of the improvements which form the subject matter of this application is to provide a fusible element of economical construction, that may be inserted or connected with electric circuit wires by unskilled labor, that will fuse at a comparatively low temperature, that can be made very small so that it will be slightly in appearance and that will be certain in its action for the purpose for which it is intended.

In the accompanying drawings which form a part of this application, we have illustrated our improved device in a magnified form for the purpose of clearly showing its construction.

In said drawing:—Figure 1 is an elevational view showing the application of one of our improved fire alarm devices applied to circuit wires; Fig. 2 is an elevation of our improved device alone; Fig. 3 is a vertical section taken through our device, in the form it appears when ready for use, and Fig. 4 is a vertical section showing the device in its operative condition.

Referring to the details of the drawing, 5 represents two circular disks of fiber, rubber or other suitable non-conductive material, through the center of which an opening is formed for the passage of the pin 10. Placed between the two disks 5 are disks 6 of similar material but of smaller diameter than the disks 5 and the same are likewise provided with a central opening through which the pin 10 passes. Surrounding the disks 6 is a metal collar 9 which forms a spacer for the two disks 5, as clearly indicated in Figs. 3 and 4. Mounted between the washers 6 is a fusible element 7 made in the form of a disk and having a central opening 8 of considerably greater diameter than the cross diameter of the pin 10 which passes through said element, as shown in Fig. 3. The pin 10 is bent at 10^a at right angles to form the por-

tion 12 which embraces the outer face of the adjacent disk 5 and said pin is again bent at right angles to provide the portion 13 which overhangs the peripheries of the disks 5. Directly below the overhanging portion 13 of the pin we place a piece of fiber 14 for the purpose of effectively insulating the pin from the adjacent portion of the collar 9, said piece 14 being held in position by the pressure of the disks 5. In applying the device above described to the wires 15, 16, of the circuit, we secure the wire 15 to the pin 10 by a lump of solder 17, and the wire 16 to the face of the collar 9 by a lump of solder 18, as clearly shown in Fig. 1.

In a device constructed substantially as described it will be apparent that when the atmosphere surrounding the device reaches the fusing point of the fusible element 7, the latter upon melting will flow against the pin 10, thereby connecting said pin with the collar 9 and closing the circuit.

In practice the collar 9 will be made of thin sheet brass or other suitable metal the disks 5 and 6 will be of a diameter approximately one-fourth of that shown in the accompanying drawings so that when applied the device will be minute as compared with the devices commonly used for the purpose stated, and at the same time will involve the use of so little material as to make the fusible element quickly respond to the action of the surrounding heat there being no extensive areas of cool metal or porcelain to be heated before the fusible element is affected as in many of the devices of this character.

From the construction above described, it will be apparent that the device can be installed on electric circuit wires by the veriest tyro in the electrical art, it being necessary merely to attach the wires by a few drops of solder to the pin 10 and the collar 9, respectively. It will also be noted that the piece 14 will prevent the bridging by the solder of the space between the pin 10 and the adjacent side of the collar. In practice we will coat the entire device with shellac or other preservative against moisture either before securing it to the wires or afterwards as may be found most expedient, thus protecting the parts against deterioration from the elements or atmospheric conditions. It will be noted that upon fusing, the fusible metal will flow against the pin irrespective of the position of the device, thus rendering the action certain under all conditions.

Having thus described our invention, what we claim is:—

1. Means for electrically connecting the wires of an electric circuit, consisting of a pin electrically connected with one of the circuit wires, a metal collar surrounding said pin and electrically connected with the other circuit wire, a fusible element in contact with said collar and spaced from said pin, said element adapted when fused to contact with both pin and collar.

2. Means for electrically connecting the wires of an electric circuit, consisting of perforated insulating disks spaced apart, a contact member passing through said disks and connected with one of the circuit wires, a collar arranged between said disks and adapted, with said pin, to hold them in position, said collar connected with the other circuit wire, a fusible member inclosed by said disks and collar and so arranged, when fused, as to contact with said pin and collar.

3. Means for electrically connecting the wires of an electric circuit, consisting of non-conducting disks spaced apart and provided with a central opening therethrough, means for holding said disks in their spaced relation, said means consisting of an element electrically connected with one branch of said circuit, and another element connected with the other branch of said circuit, in combination with a fusible means adapted when fused to connect said elements, whereby the circuit will be closed.

4. Means for connecting the wires of an electric circuit, consisting of two disks of non-conducting material spaced apart, a contact member carrying said disks connected with one branch of the circuit and

adapted to prevent the removal of said disks therefrom, a fusible member surrounding said contact member and spaced therefrom, and a second contact member surrounding said fusible member, insulated from the first named contact member and connected with the other branch of said circuit, said fusible member adapted, when fused, to electrically connect said contact members.

5. In a device for electrically connecting the wires of an electric circuit, a disk of fusible metal having a hole therethrough, a contact member passing through said hole and normally spaced from and insulated from said disk, said member connected with one branch of the circuit, a second contact member surrounding the fusible disk and electrically connected with the other branch of the circuit, and means insulating said contacts from each other.

6. Means for electrically connecting the wires of an electric circuit, consisting of a pin connected with one branch of an electric circuit, disks of insulating material mounted on said pin and spaced apart, a fusible disk mounted on said pin between said insulating disks and normally spaced from said pin, a contact sleeve surrounding said fusible disk and arranged between said insulating disks, said sleeve connected with the other branch of an electric circuit, and a moisture and air excluding coating surrounding said parts.

In testimony whereof we affix our signatures in presence of two witnesses.

BRUCE C. HALL.
FLOYD W. HALL.

Witnesses:

MARSHALL T. LOTT,
HARRY SCHENCK.