



(72) ISEN, Irvin, US

(72) KUCHEROVSKY, Joseph, US

(72) HILTON, Jackie E., US

(71) BEMIS COMPANY, INC., US

(51) Int.Cl.⁶ B41F 9/00, B41M 1/22

(30) 1995/06/07 (08/488,285) US

(54) **APPAREIL ET PROCÉDE D'IMPRESSION DIRECTE D'UN
COMPOSANT DE CIRCUIT ELECTRIQUE SUR UN
SUBSTRAT**

(54) **APPARATUS AND PROCESS FOR DIRECTLY PRINTING AN
ELECTRICAL CIRCUIT COMPONENT ONTO A SUBSTRATE**

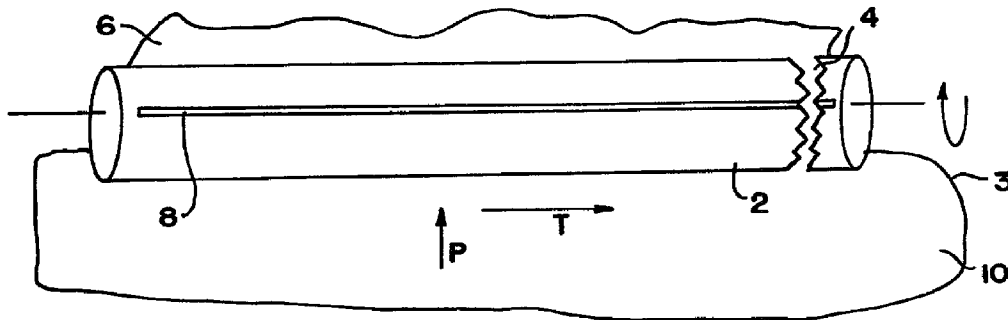

(57) Appareil et procédé permettant d'imprimer directement un composant de circuit électrique sur un substrat (52). L'appareil comprend un ou plusieurs postes d'impression (1-6) et un dispositif servant à acheminer le substrat (52) dans les postes d'impression. Le procédé consiste à imprimer directement un composant de circuit électrique sur le substrat (52) à l'aide d'un premier cylindre d'impression (56) à liquide électroconducteur (10), et à sécher le liquide avec un premier sécheur (62). De préférence, le composant imprimé du circuit électrique est apte à assurer sa fonction de circuit directement après impression et séchage, sans qu'il soit nécessaire de passer par les étapes de post-impression telles que l'attaque chimique, l'activation catalytique de l'encre et le bain chimique.

(57) Apparatus and process for directly printing an electrical circuit component onto a substrate (52) include structure and steps for providing one or a plurality of printing stations (1-6) and transporting the substrate (52) through the printing stations. Structure and steps are provided for directly printing an electrical circuit component on the substrate (52) with a first printing roller (56) using an electrically conductive liquid (10), and drying the liquid with a first dryer (62). Preferably, the printed electrical circuit component is capable of performing its circuit function directly after printing and drying, without the need for post printing process steps such as etching, catalytic ink activation, and electro-less bath.

PCT

WORLD INTELLECTUAL PROPERTY ORGANIZATION
International Bureau

INTERNATIONAL APPLICATION PUBLISHED UNDER THE PATENT COOPERATION TREATY (PCT)

(51) International Patent Classification⁶ :
B41F 9/00, B41M 1/22

A1

(11) International Publication Number: WO 96/40522

(43) International Publication Date: 19 December 1996 (19.12.96)

(21) International Application Number: PCT/US96/10011

(22) International Filing Date: 7 June 1996 (07.06.96)

(30) Priority Data:
08/488,285 7 June 1995 (07.06.95) US(71) Applicant: PARAMOUNT PACKAGING CORPORATION
[US/US]; 202 Oak Avenue, P.O. Box 902, Chalfont, PA
18914 (US).(72) Inventors: ISEN, Irvin; 100 Fairview Road, Narboth, PA
19072 (US). KUCHEROVSKY, Joseph; 9937 Wingtip
Road, Philadelphia, PA 19115 (US). HILTON, Jackie, E.;
212 Cedar Drive, Quakertown, PA 18951 (US).(74) Agents: FITZPATRICK, Joseph, M. et al.; Fitzpatrick, Cella,
Harper & Scinto, 277 Park Avenue, New York, NY 10172
(US).(81) Designated States: CA, European patent (AT, BE, CH, DE,
DK, ES, FI, FR, GB, GR, IE, IT, LU, MC, NL, PT, SE).

Published

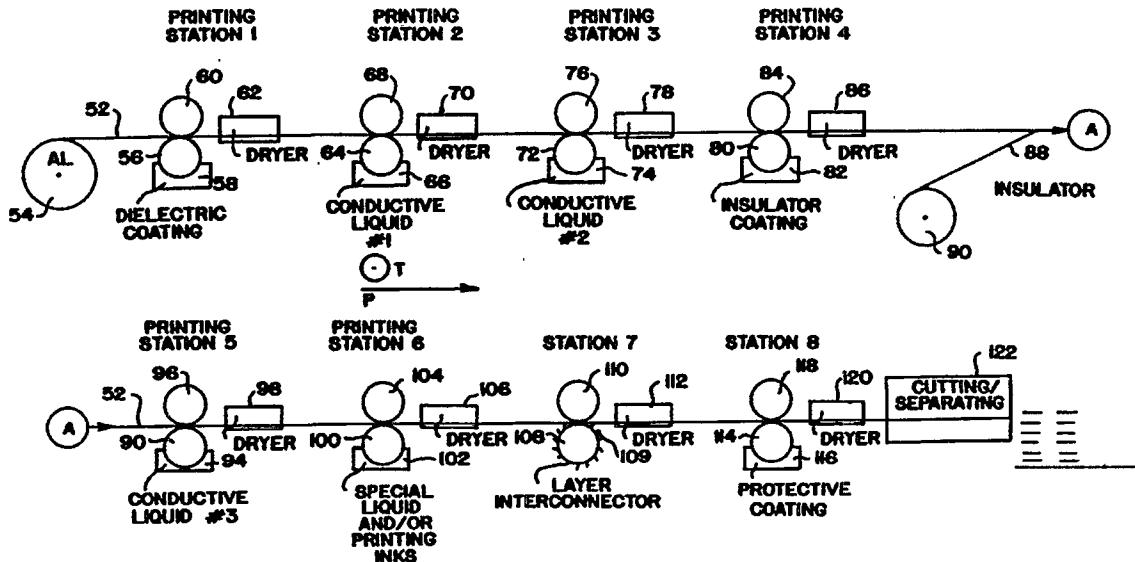
With international search report.(54) Title: APPARATUS AND PROCESS FOR DIRECTLY PRINTING AN ELECTRICAL CIRCUIT COMPONENT ONTO A
SUBSTRATE

(57) Abstract

Apparatus and process for directly printing an electrical circuit component onto a substrate (52) include structure and steps for providing one or a plurality of printing stations (1-6) and transporting the substrate (52) through the printing stations. Structure and steps are provided for directly printing an electrical circuit component on the substrate (52) with a first printing roller (56) using an electrically conductive liquid (10), and drying the liquid with a first dryer (62). Preferably, the printed electrical circuit component is capable of performing its circuit function directly after printing and drying, without the need for post printing process steps such as etching, catalytic ink activation, and electro-less bath.

1 -

APPARATUS AND PROCESS FOR DIRECTLY PRINTING
AN ELECTRICAL CIRCUIT COMPONENT ONTO A SUBSTRATE

BACKGROUND OF THE INVENTION

1. Field of the Invention

The present invention relates to apparatus and processes for directly printing an electrical circuit component onto a substrate without the need for post-printing steps such as metal etching, catalytic ink activation, and/or electroless deposition, etc.

2. Related Art

A wide variety of products contain electrical circuitry for carrying signals and/or power to perform communication, display, heating, computation, etc. Such electrical circuitry may be wired by hand, but is typically embodied in a printed circuit board installed in the product. Conventional printed circuit boards comprise a rigid, non-conductive substrate upon which conductive pathways (e.g., metal) have been formed.

Heretofore, a wide variety of processes have been used for forming the conductive pathways on the non-conductive substrate. For example, a metal film such

- 2 -

as copper can be applied to a rigid, non-conductive substrate such as fiberglass and epoxy. In a commonly-employed process, a sheet of the conductive metal is laminated to the non-conductive substrate and a photoresist is then coated on the metal sheet. The resulting printed circuit board is subsequently exposed to a light pattern using a light mask to reproduce the metal pathway pattern desired. This exposure is followed by photoresist development and then metal etching in the area unprotected by the photoresist, thereby producing the desired circuit pattern. Alternatively, an etch resist can be directly printed such as by silk screen, gravure, or the like, on the metal laminate sheet followed by curing and then metal etching. Of course, this multi-step process is slow, time-consuming, labor-intensive, and quite expensive.

Another presently available process utilizes metals or metal salts dispersed as particles in a solution, usually in a polymeric binder, and the particles function as seed sites for subsequent plating with a metal. The polymeric composition containing the metal or metal salt is applied to a substrate in a desired pattern. The composition is then heat-cured in order to drive off solvent and to cross-link the polymer. The substrate is then submerged in a metal bath or solution where metal pathways grow between the seed sites. This multi-step process is also slow and expensive. Typical examples of such processes are disclosed, for example, in U.S. Patent Nos. 3,900,320; 3,775,176; and 3,600,330.

It has also been proposed to form electrically conductive metal pathways by a process which includes coating a substrate with a composition containing a reducible metal complex. In one such process, a substrate is coated with a sorbitol copper formate

solution containing a photo-activated reducing agent. Upon exposure to ultraviolet radiation, unmasked areas are reduced to copper metal and are suitable for plating nucleation sites. Non-exposed areas are washed
5 clean and all copper formate is removed before plating can be carried out. Again, much time and expense are involved in such processes. Examples of this technology may be found in U.S. Patent Nos. 4,268,536; 4,181,750; 4,133,908; 4,192,764; 4,167,601; and
10 3,925,578.

It is also known to produce a printed circuit board by silk-screen processes in which a silk screen is placed on top of a rigid substrate and ink is pushed through
15 open areas of the silk screen onto the substrate. This, however, is not a direct printing process since the silk screen stencil must first be placed over the substrate, a high viscosity ink is then pushed through the screen onto the substrate, and then the silk screen
20 stencil must be removed. There are several inherent problems in this process. Initially, the inks must be fixed so as not to flow through the screen except where pushed, yet they must be applied with sufficient quantity and thickness of ink to flow together after
25 being applied to make a uniformly conductive surface. Furthermore, the speed of production is very slow with only a small quantity of printed circuit boards being produced with given period of time. In addition, the precision of the circuits is quite low since pulling
30 the stencil away from the substrate causes dispersion at the edges. Silk screen processing cannot produce thin or narrow lines because of the high viscosity ink. Also, silk screen inks are quite expensive and difficult to process. Silk screen processes cannot be
35 used to produce multi-layer printed circuit boards, and silk screen processes can only be used with rigid substrates since a firm backing is required to push the

- 4 -

ink through the silk screen stencil and to remove the stencil. Even if these difficulties can be overcome, silk-screening is difficult or impossible to automate fully for high speed printing.

5

In another known process, catalytic inks are applied to a substrate and are subsequently activated for plating by electroless surface treatment with noble and/or non-noble metals or salts. Typical examples of these processes are shown in U.S. Patent Nos. 4,089,993; 4,073,981; 4,100,038; and 4,006,047. The coated substrates are heat-cured and require elevated temperatures and long cure times. Again, such multi-step processes are quite expensive and time consuming.

15

A technique for producing a flexible anti-theft tag employing a resonant circuit is disclosed in U.S. Patent No. 3,913,219. According to this technique, an electrically insulated substrate has sheets of conductive foil bonded to each surface thereof. The laminated substrate is next printed on both surfaces with a black carbon ink in the particular patterns required for resonant circuit anti-theft tags. The substrate is then etched to chemically remove all of the unprinted aluminum foil on both sides of the web. The resultant conductive patterns on both web surfaces may be interconnected by welding or by coupling together the conductive surfaces. The time and costs associated with such a technique are readily apparent.

20
25
30

In summary, known processes for producing electrical circuitry such as silk-screen, catalytic ink, chemical etching, electroless bath, etc. are expensive and time consuming. What is needed is a method and apparatus for inexpensive, high-speed production of electrical component-bearing substrates, and especially printed circuit boards.

35

- 5 -

SUMMARY OF THE INVENTION

An object of the present invention is to overcome the disadvantages of known printed circuit techniques discussed above.

5

According to one aspect of the present invention, apparatus for directly printing an electrical circuit component (and/or the electrical circuit itself) onto a substrate comprises a printing station, and means for transporting the substrate to the printing station. Means are provided, at the printing station, for directly printing an electrical circuit component onto the substrate using an electrically-conductive liquid. The electrical circuit component as printed is capable of performing its circuit function and is not an intermediate-stage catalytic ink or a component upon which post-printing process steps must be performed in order for the component to perform that function.

10

15

20

According to another aspect of the present invention, a method for directly printing an electrical circuit component onto a substrate comprises the steps of providing a printing station and transporting the substrate to the printing station. At the printing station, the electrical circuit component is directly printed onto the substrate using an electrically-conductive solution.

25

BRIEF DESCRIPTION OF THE DRAWINGS

30

The present invention will be fully understood from the following detailed description of presently preferred embodiments and the accompanying drawings, in which:

35

FIG. 1 is a schematic view of a direct printing station according to the present invention;

- 6 -

FIG. 2 is a close-up view of the engraving in a prior-art picture-printing cylinder;

5 FIG. 3 is a close-up view of the engraving in a direct printing cylinder according to the present invention;

FIG. 4 is a cross-sectional view of the FIG. 3 cylinder taken along line 4-4 of FIG. 3;

10 FIG. 5 is a schematic view depicting the apparatus and process for producing directly-printed electrical components;

15 FIG. 6 is a plan view of an electrical circuit produced according to the present invention;

FIG. 7 is a cross-sectional view taken along line 7-7 of FIG. 6;

20 FIG. 8 is a cross-sectional view showing a number of electrical circuit components produced according to the present invention;

25 FIG. 9 is a cross-sectional view showing further electrical circuit components produced according to the present invention; and

FIG. 10 is a plan view of an anti-theft detection tag and activator according to the present invention.

30

DETAILED DESCRIPTION OF PRESENTLY
PREFERRED EXEMPLARY EMBODIMENTS

1. Introduction

35 The present invention employs a process we are calling the GRAVCO-PROCESS™ (The Gravco Inc. Process to be described below) to "directly print" an electrical circuit component onto a substrate. That is, the

- 7 -

conductive liquid (which forms the electrical circuit component) is transferred directly from the surface of the liquid-carrier to the surface of the substrate; the electrical circuit component is thus directly printed onto the substrate and is capable of performing its electrical circuit function, as printed, and without post-printing process steps such as catalytic ink activation, electroless bath, silk-screen stencil removal, etching, etc., known in the prior art.

Perforce, the GRAVCO-PROCESSTM is capable of producing electrical circuitry, such as printed circuit boards (flexible or rigid), using high-speed direct printing equipment known to those of skill in the art, such as rotogravure, flexographic, offset gravure, offset, and letter press, etc. The GRAVCO-PROCESSTM differs from known printing processes in that it can deposit directly, in one printing step, electrically-conductive liquid in a continuous pathway in the printing direction and in any direction oblique thereto. Since electrically-conductive pathways can be deposited continuously in any direction, high-speed, mass production printing equipment may be used for producing products such as printed circuit boards and their electrical components. Moreover, by depositing electrically-conductive liquid in any direction and in any configuration, a wide variety of electrical circuit components may be printed, such as signal lines, power lines, resistors, capacitors, resonant circuits, etc. Thus, the GRAVCO-PROCESSTM can produce highly-detailed, customized electrical circuits using high-speed mass-production printing techniques. With this invention, customized circuitry may be made at a fraction of the cost in a fraction of the time as compared to conventional printed circuit board technology.

35

- 8 -

A detailed description will now be provided of The Press; The Conductive Liquid; The Process; and The Articles according to the present invention.

5 2. The Press

The printing station equipment (see Fig. 5) utilized in the GRAVCO-PROCESS™ may be direct printing equipment known to those of skill in the art, such as rotogravure, flexographic, offset gravure, offset, or letter press. The press itself may comprise a cylinder or a plate engraved or inscribed with an image (such as an electrical circuit and/or electrical circuit component) to be reproduced. The engraving holds a liquid to be applied to a substrate or web. According to the presently preferred embodiment, the press comprises a cylinder or roller 2 depicted in FIG. 1, the roller being usable at a rotogravure printing station. The roller 2 comprises a polished copper-plated steel cylinder typically 0.1-3.0 meters in circumference. The copper plate has a plurality of liquid-carrying cells 4 engraved around the circumference of the cylinder, as shown in exaggerated form in FIG. 1. Those of skill in the art know that the cells 4 may be engraved in the copper plate by techniques such as diamond-stylus engraving, chemical etching, laser inscribing, etc.

The roller 2 contacts a bath 3 of conductive liquid 10, and is rotated so that the liquid 10 adheres to the cells 4, is carried upward in the printing direction P, and is deposited on a substrate 6 (to be described below). A doctor blade 8 is mounted in the transverse direction T and scrapes against the cylinder surface to regulate the amount of ink carried on the roller 2 and to remove excess ink therefrom.

- 9 -

FIG. 2 is a close-up view of prior art cells 4 engraved in a roller for performing prior art rotogravure picture printing. The plurality of cells 4 are connected together in the printing direction P--that is, circumferentially on roller 2. Each cell 4 is substantially 160 by 250 microns, and has a central portion 12 and a liquid communication portion 14 disposed in the printing direction P. While the central portion 12 of each cell 4 is deeper than the liquid communication portion 14 thereof, liquid ink nevertheless communicates readily in the printing direction from cell to cell. The cells 4 may be arranged with appropriate sizes, depths, and locations on the roller 2 to produce a pleasing picture when the ink is deposited on a substrate such as paper. While a black and white picture may require only one such roller, color pictures typically require four printing stations, one for each of red, blue, yellow, and black, the roller at each station bearing an appropriate array of cells for that color.

In FIG. 2, cell walls 16 are disposed so as to separate cells 4 in the transverse direction T. Ink must be prevented from flowing in the transverse direction T since this would produce a picture having unacceptable horizontal or diagonal lines therein. Furthermore, the cell walls 16 must support the doctor blade 8 which regulates the ink and removes excess ink from the roller.

FIG. 3 is a close-up view of the arrangement and disposition of cells 4 according to the present invention. According to the present invention, liquid communication channels are also provided in the transverse direction T between adjacent cells. Preferably, each cell 4 also has a liquid communication portion 18 extending in the transverse direction or in

- 10 -

a direction oblique thereto. According to the present embodiment, the transverse liquid communication portion 18 intersects the printing direction liquid communication portion 14 of an adjacent column of cells 4. In the printing process of this invention, conductive liquid according to the present invention (to be described below) is allowed to cross cell boundaries in both the printing direction P and the transverse direction T. Electrically conductive pathways can thus be configured in any direction parallel to or oblique to the printing and transverse directions.

In FIG. 3, the cell walls 16 are oriented at plus and minus 30-60 (preferably 45) degrees, respectively, with respect to the axis of roller 2. As the roller 2 rotates in the printing direction P, the thus-disposed cell walls 16 actually guide and regulate the flow of conductive liquid according to the present invention in the transverse direction to deposit an even and continuous layer of conductive liquid in any direction and in any configuration desired. The conductive liquid 10 from the bath 3 is picked-up by the cells 4 as the roller 2 rotates in the bath. Excess liquid is removed by the doctor blade 8, and the conductive liquid according to the present invention is carried to the substrate 6 where it is deposited directly thereon. While the central portion 12 of each cell 4 may be deeper than the liquid communication portions 14 and 18 thereof, when the liquid is deposited on the substrate 6, the free-flowing liquid according to the present invention tends to equalize readily in all areas where the solution contacts the substrate 6. Thus, uniform and continuous electrical pathways are formed on the substrate. The disposition of cell walls 16 depicted in FIG. 3 also provides support for doctor blade 8 in

- 11 -

the transverse direction T around the entire circumference of roller 2.

FIG. 4 is a cross-section taken along line 4-4 of FIG. 3, and depicts the relationship between cell central portion 12, liquid communication portions 14 and 18, cell walls 16, and the doctor blade 8. Sufficient voids are provided in roller 2 below the doctor blade 8 to carry the conductive liquid 10 from the bath 3 to the substrate 6. The depth of central cell portion 12 is substantially 10-100 (preferably 40 microns), and the depth of liquid communication portions 14, 18 is substantially 20-60 (preferably 20) microns. Since the columns of cells 4 in the present invention are disposed much closer together in the transverse direction, approximately 200 columns of cells are provided per inch in the present embodiment, as compared to 165 columns of cells per inch in the prior art roller depicted in FIG. 2.

While the press according to the GRAVCO-PROCESS™ has been described above with respect to a roller similar to one used in rotogravure printing, it is to be understood that the press according to the present invention may comprise a flat plate, may be made of a photopolymer or plastic, and may utilize technology similar to rotogravures flexographic, offset gravure, offset, and letter press printing. All such similar and equivalent presses are, of course, included within the scope of the appended claims.

3. The Conductive Liquid

According to the present invention, the conductive liquid (including conductive paste) utilized to form the electrically-conductive pathways may comprise a solution, a suspension, or a paste having a viscosity substantially within a range of 10 to 50,000 cp; more

- 12 -

preferably within the range of 10 - 200 cp; even more preferably within the range of 10 - 50 cp. The liquid preferably comprises a solvent and/or water (or a combination of solvent and water), solids (resins and
5 conductive powder), and plasticizers. Solventless liquids may also be used and oligimers will replace the solvent and/or water.

10 Preferably, the solvent comprises between substantially 55 percent and substantially 85 percent by weight of the liquid. (If water is used, it will comprise 25-65 percent by weight of the liquid). Even more preferably, the solvent is between substantially 65 percent and substantially 80 percent by weight; and
15 even more preferably between 70 and 75 (most preferably 72) percent by weight of the liquid. The solvent preferably includes esters, ether glycol, and ketones. Between substantially 60 percent and substantially 95 percent by weight of the solvent are esters or
20 equivalents. The most preferred embodiment includes 80 percent by weight of esters in the solvent. The solvent also should include between substantially 3 percent and substantially 20 percent, by weight ether glycols, and most preferably 10 percent. Finally, the
25 solvent includes between substantially 3 percent and substantially 20 percent by weight of ketones, most preferably 10 percent. Of course, water-based dispersions could be used in lieu of the solvent-based solution. In this instance, wetting agents and foam
30 suppressors, known to those of skill in the art, may also be used.

The preferred conductive liquid also includes between substantially 10 percent and substantially 40 percent
35 by weight of solids, most preferably 25 percent. The solids preferably include substantially 5 percent to substantially 90 percent (preferably 20 percent to 90

- 13 -

percent) by weight of polymer resin (polyester) -- a polar resin. Preferably, the polymer resins comprise 72 percent by weight of the solids.

5 The solids preferably include between substantially 3 percent and substantially 80 percent (preferably 10 percent to 80 percent) by weight of a conductive powder, most preferably 28 percent. The conductive powder comprises particles in the range of
10 substantially 3 to substantially 50 (preferably 5 - 10) microns in diameter and may comprise aluminum, graphite, gold, silver, carbon, or other known conductive materials, or any combination thereof. The choice of conductive powder will vary in accordance
15 with the component being designed, the width and thickness of the printed electrical pathway, and the current required to be carried therethrough.

20 Additionally, the conductive liquid according to the present invention preferably includes between substantially 1 percent and substantially 7 percent by weight, and most preferably between 2 and 3 percent by weight, of plasticizers. A preferred plasticizer is Dioctylphthalate.

25 Equivalents of the above-described electrically-conductive liquid may include water in addition to or as a replacement for the solvent. When replacing the solvent, the water comprises 25-65 percent by weight of
30 the liquid. Solventless liquids can also be provided where oligimers replace the solvent and comprise substantially 25-60 percent by weight of a liquid. In this formulation, the conductive powders comprise 15-50 percent by weight of the liquid, and the plasticizers
35 preferably comprise 1-5 percent by weight of the liquid. The oligimers may be activated by heat, light, electromagnetic radiation, etc.

- 14 -

The conductive liquids described above are merely illustrative and are designed to be used in signal lines for carrying low-power signals in the printed electrical circuit. Of course, a wide variety of solutions, suspensions, and/or pastes may be adapted depending upon the use for which the circuit component is designed. For example, signal lines and power lines will be highly-conductive. On the other hand, liquids used to print resistors will have a much lower conductivity. Magnetic liquids may be used to prepare inductive circuits, and electroluminescent liquids may be used to produce light-emitting circuitry. Of course, all such equivalent conductive liquids are encompassed by the present invention.

Furthermore, pigments may also be included in the conductive liquid to provide ornamental as well as functional features. Thus, not only may the conductive liquid perform an electrical circuit function, it may also be used as a label to provide information regarding the source of the goods or the product contained within the package. For example, an electrical circuit used in a child's toy may be arranged so that the circuitry spells out the toy name and/or toy instructions.

In a preferred embodiment, a conductive liquid for use in directly printing signal lines may be manufactured by pouring into a container substantially 88 percent by weight of the final liquid of AQUADAGTM liquid produced by Acheson Colloids Co., 1600 N. Washington, Port Huron, Michigan. In a separate container, 1/2-2 percent by weight of plasticizer (preferably Dioctylphthalate) is premixed by hand at ambient temperature with 10 percent by weight of solvent, esters, and/or ether glycol. After premixing the

- 15 -

plasticizer and solvent, the premix is added to the AQUADAG™ and mixed by air mixer for 15-20 minutes.

4. The Process

5 The GRAVCO-PROCESS™ for directly printing an electrical
circuit component onto a substrate is schematically
depicted in FIG. 5. The process will be described with
reference to the manufacture of a computerized pill
dispenser article which is depicted in FIG. 6. Such an
10 article is used to monitor and schedule the
dispensation of drugs in pill form. In FIG. 6, a pill
in a plastic blister is disposed over top of each
curved conductor line. The substrate beneath the
conductor line is aluminum foil or some other easily-
15 tearable surface. The pill dispenser is placed in a
computerized monitoring device (not shown), and the
device will send signals through the signal lines to
determine the electrical continuity of each line. As
each pill is dispensed, it is pushed downward through
20 the aluminum substrate, severing the signal line to
indicate that that pill has been dispensed. A display
on the device will indicate which pills have been
dispensed and when; the display may also indicate when
the next pill should be dispensed. Where the pill
25 dispenser has on-board signal generating, memory, and
display circuitry, it is even possible for the
dispenser itself to determine the time at which the
pill was dispensed, and the time the next pill is
scheduled to be dispensed.

30

The process of FIG. 5 feeds a substrate (web) of 1 mil
aluminum foil 52 from a roller 54 to printing station 1
which is configured similar to a well-known rotogravure
printing station. At printing station 1, a roller 56
35 sits in a bath of dielectric coating 58 and rotates to
deposit a thin but continuous layer of dielectric over
the bottom surface of aluminum sheet 52. The

- 16 -

dielectric coating is preferably a polymer resin and solvent solution 10 microns thick which prevents any electrical contact with the aluminum sheet 52. A pinch roller 60 is disposed on the other side of aluminum foil 52 and ensures a uniform dispersal of dielectric coating on the aluminum sheet 52.

Printing station 1 also includes a dryer 62 which dries the dielectric coating on the sheet 52. The dryer may comprise a hot air oven (5 feet long @ 200° C.) directing an air blast at the foil for 0.5 - 1.5 seconds.

After exiting printing station 1, the sheet 52 is fed to printing station 2 where a roller 64 (for example, the roller 2 described above) sits in a bath 66 of conductive liquid #1 at ambient temperature. Since the conductive liquid may contain powders, an ink agitation system may be used in bath 66. This first conductive liquid will be used for signal lines, power lines, and other high-conductivity uses, and may comprise the conductive liquid described above. The roller 64 will have a pattern of cells 4 disposed in the printing direction P, in the transverse direction T, and in any directions oblique thereto. Preferably, the roller 64 is wide enough to simultaneously print seven electrical circuits as depicted in FIG. 6. Again, a pinch roller 68 will ensure a proper printing, and a dryer 70 will dry the conductive liquid #1. While the dryer 70 may comprise a hot air oven, as described above, preferably it is a microwave or radio frequency generator (e.g., 27 megahertz) which will dry the conductive liquid internally and not just the skin, which is a problem with air dryers. Thus, at printing station 2 the electrical circuit and its components are directly printed in a single operation without the post-printing operations described earlier.

- 17 -

At printing station 3, a print roller 72 will apply conductive liquid #2 from bath 74 onto the sheet 52. Conductive liquid #2 is less conductive than liquid #1 and is used to deposit components such as resistors. Again, a pinch roller 76 and a dryer 78 are used to print and dry the conductive liquid #2. Alternatively, printing station 3 could apply an additional layer of conductive liquid #1 over the previous layer to form a thick circuit, such as a power line.

Where the circuits require an insulating layer to be deposited on top of conductive liquids #1 and #2, a printing station 4 may be provided. At printing station 4, the print roller 80 sits in a bath of insulator coating 82 (such as a lacquer) to deposit a specified thickness of insulation over top of the conductive liquids. The insulator coating is deposited at any thickness required by the circuit. For example, to form a capacitor, the insulator layer may be 1 micron to 1000 (preferably 500) microns thick. However, if a push-pad switch is being produced, the thickness of the insulator layer may be less, such as 10 microns. As with the previous printing stations, printing station 4 includes a pinch roller 84 and a dryer 86.

Alternative to printing station 4, or in addition thereto, a laminating insulator material 88 may be applied from a roller 90. For example, the insulator 88 may comprise paper, polymeric plastic, or any other flexible insulating substrate or web. The insulator 88 may have holes or electrically conductive patterns therein to allow electrical contact between the conductive liquid #1 and later-deposited conductive layers, if desired. The holes in insulator 88 may be small enough so that contact is only established by pushing the two conductive layers together through the

- 18 -

insulator 88 to produce, for example, a push-pad switch. In addition to laminating an insulator material, a roller may be provided for laminating one or more conductive layers (such as metallic foil) for additional signal or power channels, or for radio frequency shielding, as desired. Specific circuit details will be described later.

In FIG. 5, the sheet 52 is then transported to printing station 5 where a print roller 90 applies conductive liquid #3 from a bath 94 to the sheet 52 on top of the insulating layer. Conductive liquid #3 may comprise a highly-conductive liquid similar to conductive liquid #1. Again, this liquid may be used for upper-layer signal lines, power lines, capacitors, etc. A pinch roller 96 and a dryer 98 are also provided at printing station 5. Again, one or more layers of conductive liquid #3 may be printed, as desired.

If desired, a printing station 6 may be provided wherein any one or more of specialty liquids and/or printing inks may be applied. For example, special effects liquids may be provided such as thermochromic liquids, electrophosphorescent liquids, magnetochromic liquids, electrochromic liquids, zinc oxide (glow-in-the-dark) liquids, electroluminescent liquids, magnetic liquids, etc. If desired, more than one printing station may be provided for applying a series of such specialty liquids. In addition to, or as an alternative to the specialty liquids, graphic printing inks may be provided for affixing well-known labels, instructions, or decorations to the product. These inks may include conductive liquid so that the graphic image may comprise an electrical circuit and/or component. At the printing station 6, a print roller 100 transfers the specialty liquid and/or the printing

- 19 -

ink from a bath 102 and applies it to sheet 52 aided by a pinch roller 104 and a dryer 106.

At station 7, a spiked roller 108 is used to provide appropriate layer interconnects between the upper and one or more lower layers of conductive liquid. Each spike 109 will penetrate through the conductive liquid #3, the insulating layer, and the conductive liquid #1 and/or #2 to make an electrical contact between the upper and lower conductive layers. If dryers 98 and 106 are not activated (or are preferably modulated), the conductive liquid #3 will still be in liquid or semi-liquid form when spike 109 penetrates through the insulating layer to the lower conductive layer. The conductive liquid will move through the interconnect hole and make a good electrical contact with the lower conductive layer. Preferably, the spiked roller will be disposed before the upper conductive layer printing station so that the printing of the upper layer will force liquid under pressure into the interconnect hole. Of course, the number, location, and depth of each of these spikes 109 may be specially designed depending upon the particular circuit which is being manufactured. As an alternative, the roller 108 may sit in a bath (not shown) of conductive liquid to further enhance the inter-layer electrical contact. At station 7, the spiked roller may be a punch roller press, a male-female die; or a backing roller or other device 110 may be used to provide proper support for the penetrating spikes 109. A dryer 112 may be used, if desired, to dry the conductive liquid connecting the conductive layers. Alternatively, crimps, rivets or other electrical conductors (preferably those which can be installed in an in-line process) may be used to electrically couple two or more conductive layers.

- 20 -

Station 8 is equipped to provide a protective coating over the top of the finished electrical circuit. The roller 114 applies a protective coating from bath 116 to cover the surface of the finished product. The protective coating may comprise lacquer, polymeric plastic, etc. A pinch roller 118 (or smoothing bar) and a dryer 120 may be provided, if desired. A cutting/separating unit 122 may be provided to cut, separate, and stack separate electrical circuits. Alternatively, the sheet containing the printed circuit boards may be rewound onto another roller for shipping and subsequent processing. These units are reasonably well known to those of skill in the art and will not be described in further detail herein.

The process described above with respect to FIG. 5 is capable of infinite variation depending upon the electrical circuit being produced. For example, three, four, or five conductive layers may be provided with (or without) interspersed insulating layers. Conductive liquids may be printed on top of each other to build thick components, e.g., 5 layers for a power line. The spiked roller 108 may be provided at any station or in between stations depending upon the interconnections required among the various conductive layers (e.g., to interconnect layers 1 and 2, and then 4 and 5). The insulating layers may be transparent or may be light-blocking. The type of conductive liquid and the pattern dimensions may be adjusted to achieve desired electrical characteristics such as resistance ohms, capacitor picofarads, the wattage of any power line, current, inductance, reactance, etc. The characteristics of the insulator coatings may be chosen for desirable insulating properties such as breakthrough voltage, tangent losses, etc. Additional aluminum sheets and/or conductive layers may be inserted via roller, as with the insulator roller 90,

- 21 -

at any point in the process. The aluminum sheet may act as a ground plane for all of the electrical components, or may carry power to all of the circuits disposed above the dielectric layer, or may shield the circuit from electromagnetic or static electric interference.

As another alternative, an additional station (not shown in FIG. 5) may be provided at any point in the process for checking the quality of the already-printed circuits. For example, a roller may be provided having a plurality of electrodes disposed thereon which are arranged (registered) to come into contact with appropriate terminals on the sheet 52 passing beneath the roller. The electrodes on the roller will be activated (pulsed) to run continuity checks, resistance checks, voltage checks, amperage checks, etc., through the terminals in contact with the roller electrodes, etc. High-speed in-line quality checks will ensure a highly reliable product by quickly identifying failed circuits for removal at cutting/separating device 122. Alternatively, defective products may be marked as the sheet 52 is being rewound.

As yet another alternative, the process depicted in FIG. 5 may be "looped" from station 8 back to station 1 so that further additional conductive and insulating layers may be deposited and interconnected, as required.

As a further alternative, the electrical circuit may be formed on a flexible substrate (such as a 1 to 15 (preferably 1) mil thick polymeric plastic), and then bonded to a rigid substrate, such as an epoxy-fiberglass composite. Such a product is still far less expensive to produce than the known methods of producing known rigid printed circuit boards.

- 22 -

While the substrate depicted in FIG. 5 comprises a flexible aluminum foil, other flexible substrates may be utilized, such as polymeric materials to include
5 films, plastics, combinations, coextrusions, laminations, non-woven polymeric fabrics, cloth, paper, wool, etc. Also, while flexible substrates are preferred, semi-rigid or relatively rigid substrates can also be used including polyamide, polycarbonate,
10 polyester, mylar, lexan, kevlar, cardboard, acrylics, acetate, foamed or foamable polymers, fiberboard, etc. Rigid substrates can be provided in many forms including for example, ceramics, glass, plastics, paper compositions, or composite substrates such as epoxy-
15 fiberglass, epoxy-paper laminate, etc.

The conductive liquid printed according to the GRAVCO-PROCESSTM may be of any practical thickness, length, and width desired. The thickness may vary from one
20 molecular layer to 200 microns, or even up to 500 microns if desired. Since the liquid can be made to be relatively free-flowing, very thin, closely-spaced components may be printed. This flexibility provides the circuit designer with a wide range of circuit
25 component values which can be accommodated by the GRAVCO-PROCESSTM.

5. The Articles

An extraordinarily wide variety of useful articles may
30 be produced according to the GRAVCO-PROCESSTM, and hence many products that have never been practical or cost-effective will become available as a result of this invention. For example, FIG. 6 depicts one article useful for the reliable dispensation of drugs. Some
35 patients are forgetful or uncertain as to whether and when certain drugs have been or should be dispensed. A drug dispensation system in which it is positively

- 23 -

known when the last drug was dispensed and when the next drug should be dispensed is quite important. FIG. 6 depicts a plan view of a drug dispenser article which may accurately and reliably schedule drug treatment.

5 The circuit shown in FIG. 6 may be produced according to the GRAVCO-PROCESSTM described above, and its use will be described below. Drug dispenser article 200 has a plurality of electrodes 202 disposed along one edge thereof. The electrodes 202 are configured to be

10 inserted into a computerized drug scheduler (not shown). Signal lines 204 extend from electrodes 202 and back to matching electrodes 206, making a continuous electrically conductive path from electrodes 202 to electrodes 206. The signal lines 204 include

15 curvilinear portions 208 which are preferably disposed on aluminum foil immediately beneath a pill 210 contained within a plastic blister 212.

In order to dispense a pill, the patient pushes the

20 pill 210 through the aluminum foil at the bottom of the article 200, thus severing signal line 208. The severing of the signal line 208 is detected by the computerized scheduler, and the time is noted therein. The computer now has a schedule indicating the identity

25 of and time that each pill was removed from the article 200. The patient merely observes the display of the computerized scheduler to determine when the last drug was taken, and when the next drug is scheduled to be taken.

30 FIG. 7 is a cross-section view of a portion of the article 200 as viewed along lines 7-7, of FIG. 6. The flexible aluminum foil 52 has disposed thereon a dielectric coating 58, as has been described above with

35 reference to FIG. 5. Signal lines L_{S1} and L_{S2} are deposited thereover and carry signals. A thicker line L_p may be provided as a bus line for communication, as

- 24 -

a circuit-matching resistor, or as a power line for carrying power, if required. Disposed over top of the signal lines is a protective coating 116 of, for example lacquer, as described earlier with respect to
5 FIG. 5.

FIG. 8 is a cross-sectional view of a number of alternative circuit components which may be produced according to the GRAVCO-PROCESSTM described above. All
10 circuits are depicted as being printed on a substrate layer 53, such as 1-2 mil polymeric plastic. A capacitor C_1 is provided having plates 802 and 804 separated by an insulating layer 806. The capacitor plates 802, 804 and the insulating layer 806 are
15 dimensioned to produce the appropriate capacitance required for the circuit. Of course, the capacitor plates 802, 804 are coupled to other conductive circuitry (not shown).

20 A switch SW_1 is also shown in FIG. 8 and may comprise electrodes 808 and 810. The electrodes are separated by an insulating layer 812 which may comprise an insulating material having a plurality of voids or holes therein. Pushing down on electrode 810 will
25 cause it to make contact with electrode 808, thus closing switch SW_1 . If the insulating layer 812 has elastic properties, releasing pressure on electrode 810 will cause the switch to open.

30 Energy source (battery) E_1 is also shown in FIG. 8 and comprises electrode 816, electrolyte 818, and electrode 820. The electrolyte 818 preferably comprises micro-encapsulated liquid electrolyte (e.g., alkalines) which may also be deposited via the GRAVCO-PROCESSTM printing
35 techniques described above. Alternatively, the electrolyte may comprise a liquid or a gel encased in a plastic blister which is deposited on the electrode 816

- 25 -

in an in-line process, as depicted in FIG. 5 for insulator 88. When the power source is ready for activation, the electrolyte 818 may be activated by the user pressing thereon, or some other process can be applied for causing the electrolyte 818 to make contact with both electrodes 816 and 820 (e.g., mechanical pressure, electrical activation, heating, photo-stimulation, etc.). Such a power source may be a simple short-term, one-shot power supply, or it may provide longer-lasting, higher-power similar to known 1.5-volt batteries, depending upon the number of electrodes and the type of electrolyte used. In a preferred embodiment, a battery may be printed by printing a carbon electrode on a substrate, depositing a dry alkaline on top of the carbon electrode, and printing a zinc electrode over the dry alkaline. The zinc will have a plurality of holes therein so that dipping the battery in water will liquidify the alkaline thus activating the electrolyte to power the battery. If higher voltages are needed, a plurality of such batteries may be connected in series, or an increase in battery current may be achieved by connecting a plurality of such batteries in parallel.

Also depicted in FIG. 8 is a simple resistor R_1 which may provide a resistance depending upon the thickness, width, length, and type of conductive liquid used therefor.

FIG. 9 depicts further articles which may be produced according to the GRAVCO-PROCESSTM described above. FIG. 9 shows how a through (or interconnect) hole 822 which may be provided between signal lines L_{S1} and L_{S2} . The through hole 822 may be produced, for example, by the spiked roller 108 depicted in FIG. 5. FIG. 9 also depicts a light electrode LE1 which may, for example, comprise an electroluminescent layer. Upon application

- 26 -

of the appropriate current, LE1 will emit photons for a time and intensity depending upon the composition of the solution and the applied current and voltage.

5 FIG. 10 depicts a theft-detection tag produced according to the GRAVCO-PROCESSTM described above. Such tags may also be used for registering inventory, identifying products, tracking hospital patients (newborns), anti-shoplifting, product labeling, etc.

10 The anti-theft tag of FIG. 10 comprises a resonant circuit printed on both the top and bottom of an insulating substrate, for example, paper, cardboard, polymer films, nonwoven fabrics, cotton cloth, silk, etc. The top and bottom circuits may be connected by

15 folding, welding, or interconnecting as described above with reference to FIG. 5. The resonant circuit comprises a conductive coil 900 having a thin, 1 mm long, 0.25 mm wide bridge-portion 902 disposed therein. When the theft-detection tag passes through a detector

20 unit (not shown), RF energy emitted by the detector unit causes the circuit to resonate and act as a transmitter, giving off RF energy which may be detected by the detector. If the product has been properly purchased, a microwave capacitor 904 disposed near the

25 cash register may emit a low-power microwave ray to burn and sever the bridge 902, thus decoupling the resonant circuit and permitting the tag to be removed from the store through the detector apparatus without alarm. Of course, other ways of decoupling the

30 resonant circuit may be used, such as mechanical severing, magnetic alteration, etc. Very few articles of clothing currently have theft-detection circuits affixed thereto because known circuits are not cost-effective. However, according to the GRAVCO-PROCESSTM,

35 cotton or silk clothing labels bearing both product information and anti-theft circuitry may be produced in an in-line, high-speed process at low cost.

- 27 -

A wide variety of other articles may be produced according to the GRAVCO-PROCESSTM described above. For example, heating circuits can be printed on plastic sheeting which is laminated to a thermoformable plastic substrate, the laminate being subsequently thermoformed into a three dimensional product. Such a process can produce food trays made of foamed polymers may have heating circuits printed in the bottom thereof, so that food may be heated with an available electrical circuit, for example, a cigarette lighter in a car. Such a heating element may also be printed in coffee cups, soup cups, hot cereal containers, baby bottles, etc. The circuit need only have two electrodes and an appropriate number of resistors disposed near the product to be heated. Also, food products can be heated within flexible pouches with printed heating elements.

Other heating applications are also susceptible to the GRAVCO-PROCESSTM described above. For example, space heaters (e.g., for use in a van or trailer) may be produced by thermoforming large sheets of a semi-rigid substrate (e.g., foamable polymeric composites). Printed on the substrate (prior to thermoforming) would be a plurality of heating elements produced according to the GRAVCO-PROCESSTM. The heating elements could be readily configured to provide high heat or low heat and for a particular space desired. The heating elements could even be produced in interconnectable modular form. Power could be provided through a vehicle cigarette lighter, from a vehicle alternator, or from a wall outlet for use in a building space heater.

Heating elements may also be printed on cloth or on the non-woven polymer fabrics discussed above. This could result in inexpensive heated products such as heated

- 28 -

blankets, heated towels, heated socks, heated mittens, heated caps, heated clothes, heated automobile seats, heated furniture, etc.

5 Furthermore, large sheets of polyethylene having heated elements printed thereon may be produced for use in hot houses for personal or commercial use. The heating elements may be designed to produce a wide range of
10 btu's depending on the type of hot house being assembled.

Alternatively, electrical circuits produced according to the GRAVCO-PROCESSTM may be used to cool products. It is well known that semi-conductor materials (P-N
15 junctions) may generate heat or absorb heat depending upon the current (and direction of current) applied thereto. All of the above-noted heating applications may have complementary cooling applications which can be satisfied according to the electrical circuits
20 produced by the GRAVCO-PROCESSTM. As one example, the foam labels adhered to soda bottles may have circuitry printed therein to absorb heat from the bottle, thus cooling the liquid. The cooling circuitry may be coupled to an external power source, or a power source
25 may be printed into the label, as described above. Thus, the GRAVCO-PROCESSTM may produce a great number of products capable of being heated and/or cooled.

Electrically conductive liquids may also be printed
30 according to the GRAVCO-PROCESSTM on documents requiring authentication, such as bonds, stocks, currency, etc. Electrical circuitry having particular characteristics may be printed on the document and later verified with a small electrical authenticator which ascertains the
35 characteristics of the electrical circuit printed on the document.

- 29 -

Furthermore, electrically conductive liquids may be printed according to the GRAVCO-PROCESSTM to perform the function of product registration in well-known in-line bag-making, sheeting, or pouch-making processes and in any process requiring position detecting and triggering. Currently, a large black or dark registration mark is provided on a bag web. An optical reader determines the location of the registration mark to control the feeding, and cutting of the printed web. However, optical readers are susceptible to dirt and other reliability problems. By using a conductive ink as a small registration mark, a small roller (or wheel) with one or more electrodes thereon may be used to detect the passage of the conductive ink registration mark, e.g., with a continuity check.

Microwave susceptors may also be printed into products to be used in microwave ovens, such as microwave popcorn bags or boxes (plastic or paper). Currently, microwave susceptors must be mechanically (or manually) inserted into pouches or between layers of a microwave container, (e.g., a popcorn bag). With the GRAVCO-PROCESSTM, such susceptors may be printed on or within container layers in an in-line, low-cost process. Indeed, the GRAVCO-PROCESSTM may combine printing electrically conductive circuits with ornamental labels, as discussed earlier. Thus, the name of the microwave popcorn manufacturer may be printed with an electrically-conductive liquid so that the manufacturer's name itself acts as a microwave susceptor.

Electroluminescent liquids may be advantageously used in light-up displays attractive to the consumer. For example, soda cans may be printed with electroluminescent liquids, power lines, and terminals

- 30 -

5 using the GRAVCO-PROCESSTM described above. The soda can display at the store may have matching electrodes and a power source such that the displayed soda cans actually light up with the manufacturer's name and/or trademark.

10 Furthermore, tamper-evident packaging may also be created utilizing electrical circuits produced by the GRAVCO-PROCESSTM described above. For example, signal lines may be printed on shrink-wrap product coverings such that the signal lines break to show tampering. A simple circuit located at the cash register would be used to detect broken signal lines indicating that the package had been tampered with.

15 As described above, any known or useful electrical circuit can be produced according to the GRAVCO-PROCESSTM including, but not limited to, signal lines, power lines, connectors, switches, antennas, induction heaters, radiant heaters, coolers, radiation
20 reflectors, diodes, capacitors, transistors, resistors, inductors, coils, batteries, sensors, fuel cells, piezoelectric elements, light emitting circuits, photovoltaic cells, photo-imaging cells, etc.

25

6. Conclusion

Thus, what has been described above is a method and apparatus for the high-speed mass production of electrical circuit components by directly printing
30 electrically conductive liquids onto a substrate without post-printing processes. The GRAVCO-PROCESSTM is far superior to the best-known printed circuit board techniques, such as silk-screen. The GRAVCO-PROCESSTM can produce printed circuit boards 10-50 times faster
35 than silk-screen processes. The precision and geometric tolerances produced according to the present invention are also far superior to silk-screening since

- 31 -

a stencil does not have to be pulled away from the substrate allowing the thick ink to cause dispersion at the edges. The silk-screen process can produce signal line the order of 500 microns, whereas the present invention can produce signal lines tolerances an order of magnitude narrower. Silk-screen inks are also quite expensive, from 600-700 dollars per pound, orders of magnitude more expensive than the present invention. In addition, a large amount of ink wastage is seen in silk-screen processes, where the present invention will waste very little ink. The present invention can miniaturize or downsize circuits because the direct printing process can produce much finer and smaller dimensions than silk-screen stencils. For example, silk-screen processes can only approximately space signal lines 2 millimeters apart, whereas the present invention can space signal lines approximately 0.1 millimeters apart. Further, the GRAVCO-PROCESSTM can easily produce multi-layer circuitry, whereas silk screening can only produce a single layer. Finally, silk-screen processes cannot print circuit boards on flexible substrates, whereas the present invention can print on one mil flexible substrates such as plastic, paper, or aluminum foil. Accordingly, the present invention can produce electrical circuit components and/or electrically circuits at a fraction of the cost and in a fraction of the time of the best-known current printed circuit board techniques.

While the present invention has been described with what are presently considered to be the preferred embodiments, the claims are not to be limited to the disclosed embodiments. To the contrary, the claims are intended to cover various modifications and equivalent structures and functions as are apparent from the appended claims.

- 32 -

WHAT IS CLAIMED IS:

1. Apparatus for directly printing an electrical circuit component onto a substrate, comprising:
- 5 a printing station;
means for transporting the substrate to said printing station; and
means for directly printing, at said
- 10 printing station, an electrical circuit component onto the substrate using an electrically-conductive liquid.
2. Apparatus according to Claim 1, wherein said means for printing prints the electrical circuit
- 15 component in one printing step, the electrical circuit component being capable of performing its circuit functions without post-printing steps.
3. Apparatus according to Claim 1, wherein said means for printing prints an electrical circuit
- 20 component comprising at least one of: a signal line; a power line; a resistor; a capacitor; an inductor; a diode; a coil; a transistor; a battery; an antenna; and a switch.
- 25
4. Apparatus according to Claim 1, wherein said printing station comprises at least one of a rotogravure printer, an offset gravure printer, a flexographic printer, an offset printer, and a letter
- 30 press.
5. Apparatus according to Claim 1, wherein said means for transporting transports a substrate comprising at least polymeric plastic, paper, flexible
- 35 fiber board, non-woven polymeric fabrics cloth, and metallic foil.

- 33 -

6. Apparatus according to Claim 1, further comprising a dielectric printing station, and means for printing, at said dielectric printing station, a dielectric material between the substrate and the electrical circuit component.

7. Apparatus according to Claim 1, further comprising an insulator printing station, and means for printing, at the insulator printing station, an insulator material on top of said electrical circuit component.

8. Apparatus according to Claim 7, further comprising a second printing station, and means for printing, at the second printing station, a second electrical circuit component on top of said insulator material.

9. Apparatus according to Claim 8, further comprising means for electrically connecting the second electrical circuit component to the electrical circuit component.

10. Apparatus according to Claim 1, further comprising means for drying the printed electrically-conductive liquid.

11. Apparatus according to Claim 10, wherein said means for drying comprises an electromagnetic field generator.

12. Apparatus according to Claim 1, further comprising means for printing an insulating layer over said electrical circuit component, and means for printing a second electrical circuit component over top of said insulator layer, and means for punching through the second electrical circuit component and the

- 34 -

insulator layer to electrically connect the second electrical circuit component and the electrical circuit component.

5 13. Apparatus according to Claim 1, further comprising means for depositing a protective layer over said electrical circuit component.

10 14. Apparatus according to Claim 1, wherein said substrate comprises a flexible substrate, and further comprising means for overlaying onto a rigid substrate the flexible substrate having the electrical circuit component thereon.

15 15. Apparatus according to Claim 1, wherein said means for printing prints first and second battery electrodes, and further comprising means for depositing a battery electrolyte between said first and second battery electrodes.

20 16. Apparatus according to Claim 1, wherein said means for printing prints a resonant circuit.

25 17. Apparatus for directly printing an electrical circuit component onto a flexible substrate, comprising:

 a printing station;
 means for transporting the flexible substrate to said printing station; and
30 means for directly printing, at said printing station, an electrical circuit component onto the substrate using an electrically-conductive liquid, the electrical circuit component extending in a printing direction in a direction transverse thereto so
35 that the electrical circuit component, as printed, is electrically conductive in the printing direction and in the transverse direction.

- 35 -

18. Apparatus according to Claim 17, wherein said means for directly printing prints in electrical circuit comprising a plurality of electrical circuit components.

5

19. Apparatus according to Claim 17, wherein said means for transporting transports a substrate comprising polymer film.

10

20. A method for directly printing an electrical circuit component onto a substrate, comprising the steps of:

providing a printing station;

transporting the substrate to the printing

15

station; and

directly printing, at the printing station, an electrical circuit component onto the substrate using an electrically-conductive liquid.

20

21. A method according to Claim 20, wherein said printing step prints an electrical circuit component capable of carrying out its electrical circuit functions without post-printing steps.

25

22. A method according to Claim 20, wherein said printing step prints an electrical circuit component comprising at least one of: a signal line; a power line; a resistor; a capacitor; an inductor; a diode; a coil; a transistor; a battery; an antenna; and a

30

switch.

35

23. A method according to Claim 20, wherein the step of providing a printing station includes the step of providing one of a rotogravure printer, an offset gravure printer, a flexographic printer, an offset printer, and a letter press.

- 36 -

24. A method according to Claim 20, wherein said transporting step transports a substrate comprising at least one of polymeric plastic, paper, flexible fiber board, non-woven polymeric fabrics, cloth, and metallic foil.

25. A method according to Claim 20, further comprising the step of providing a dielectric printing station, and further comprising the step of printing, at the dielectric printing station, a dielectric material between the substrate and the electrical circuit component.

26. A method according to Claim 20, further comprising the step of providing an insulator printing station, and further comprising the step of printing, at the insulator printing station, an insulator material on top of the electrical circuit component.

27. A method according to Claim 26, further comprising the step of providing a second printing station, and further comprising the step of printing, at the second printing station, a second electrical circuit component on top of said insulator material.

28. A method according to Claim 27, further comprising the step of electrically connecting the second electrical circuit component to the electrical circuit component through the insulator material.

29. A method according to Claim 20, further comprising the step of drying the printed electrically-conductive liquid.

30. A method according to Claim 29, wherein the step of drying comprises the step of drying with an electromagnetic field generator.

- 37 -

31. A method according to Claim 20, further comprising the steps of:

directly printing an insulator layer over top of the electrical circuit components;

5 directly printing a second electrical circuit component on top of said insulator layer; and

interconnecting the second electrical circuit component and the first electrical circuit component through said insulator layer.

10

32. A method according to Claim 20, further comprising the step of depositing a protective layer over the electrical circuit component.

15

33. A method according to Claim 20, wherein the step of transporting the substrate comprises the step of transporting a flexible substrate, and further comprising the step of overlaying, onto a rigid substrate, the flexible substrate having the electrical circuit component printed thereon.

20

34. A method according to Claim 20, wherein said printing step prints first and second battery electrodes, and further comprising the step of depositing a battery electrolyte between the first and second battery electrodes.

25

35. A method according to Claim 20, wherein said printing step comprises the step of printing a resonant circuit.

30

36. A method for directly printing an electrical circuit component onto a flexible substrate, comprising the steps of:

35

providing a printing station;

transporting the flexible substrate to the printing station; and

- 38 -

directly printing, at the printing station,
an electrical circuit component onto the substrate
using an electrically-conductive liquid, the electrical
circuit component being printed in a printing direction
5 and in a direction transverse thereto such that the
electrical circuit component, as printed, is
electrically-conductive in both the printing direction
and in the transverse direction.

10 37. A method according to Claim 36, wherein said
step of directly printing prints an electrical circuit
comprising a plurality of electrical circuit
components.

15 38. A method according to Claim 36, wherein said
transporting step transports a polymeric film
substrate.

20 39. A product produced by the process according
to Claim 20.

25

1/6

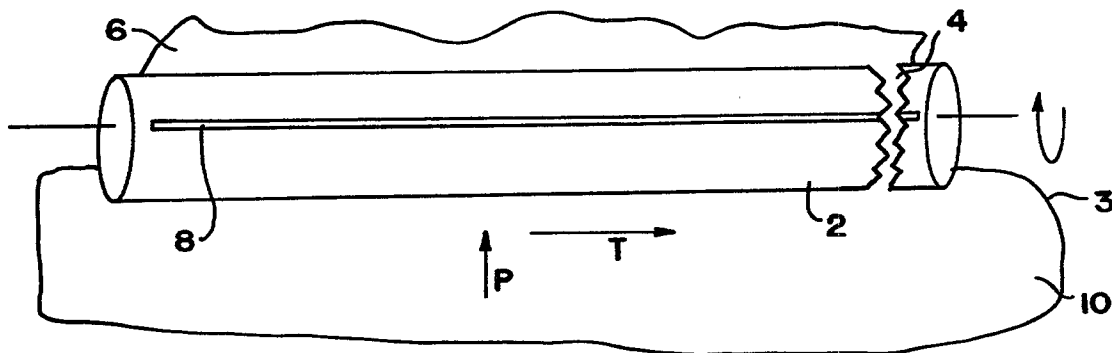

FIG. 1

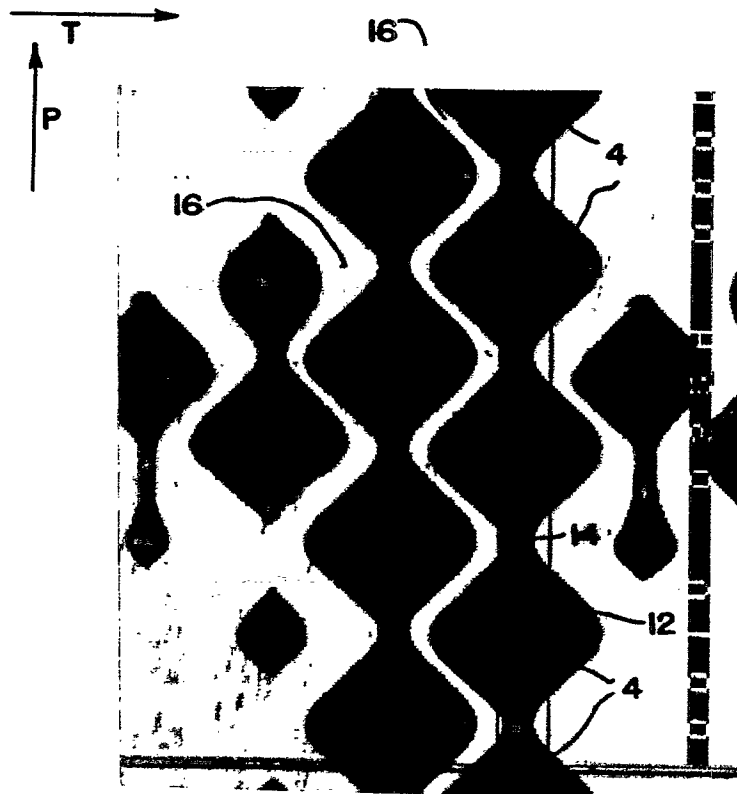

FIG. 2
PRIOR ART

2/6

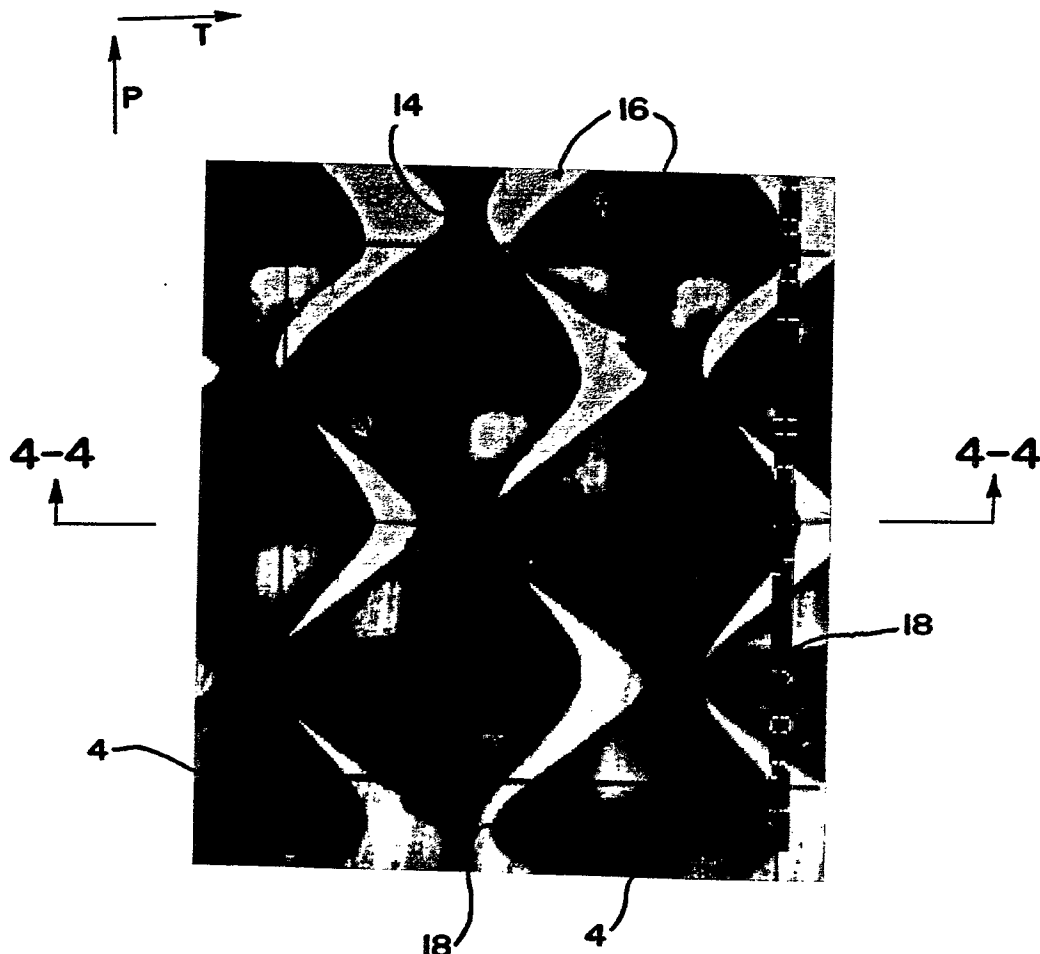

FIG. 3

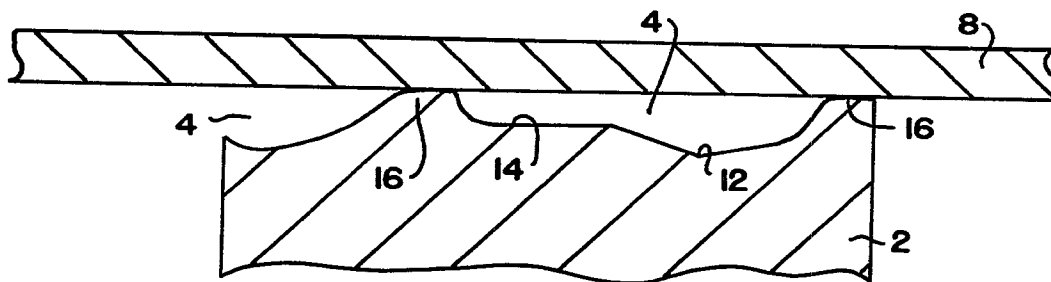

FIG. 4

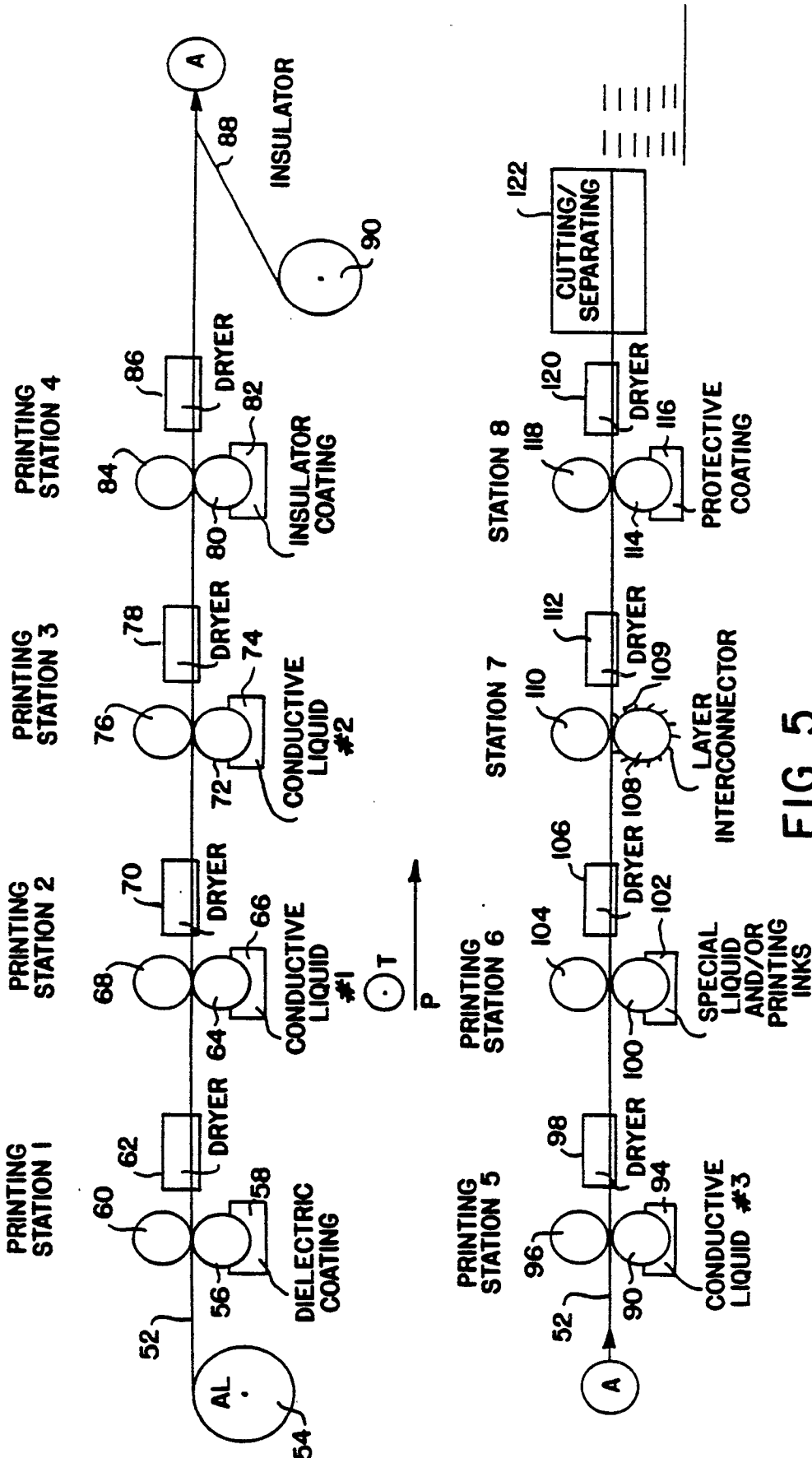

FIG. 5

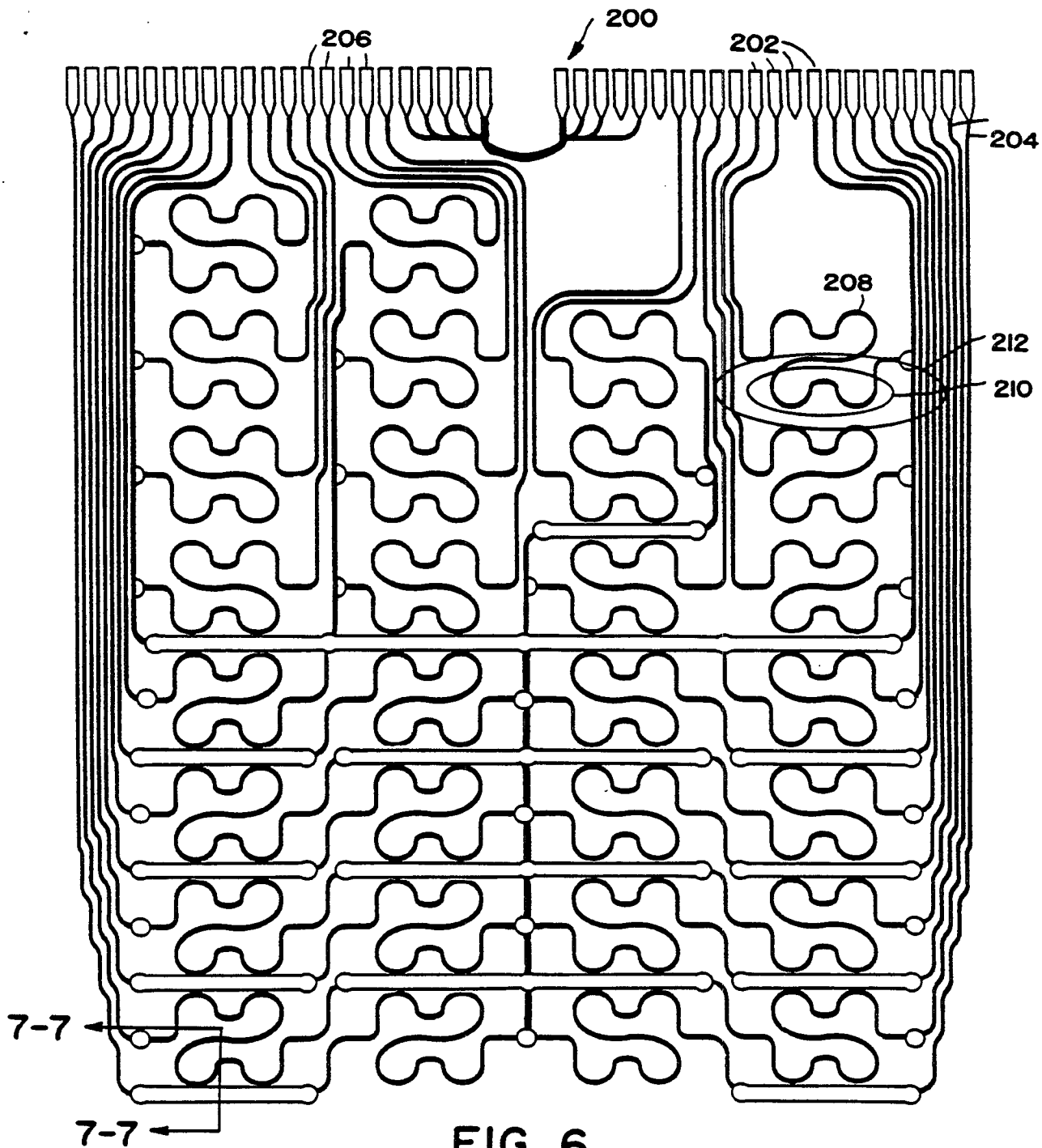

FIG. 6

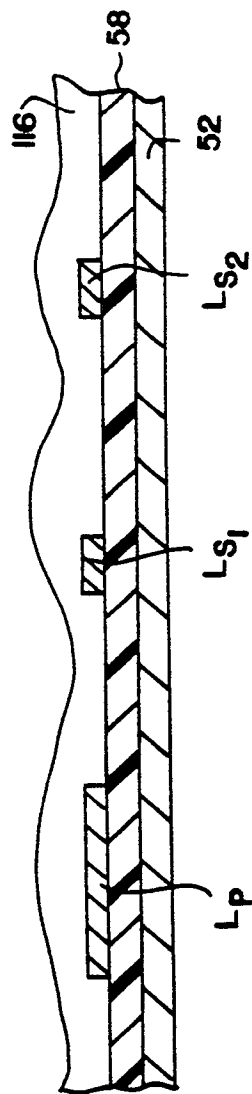

FIG. 7

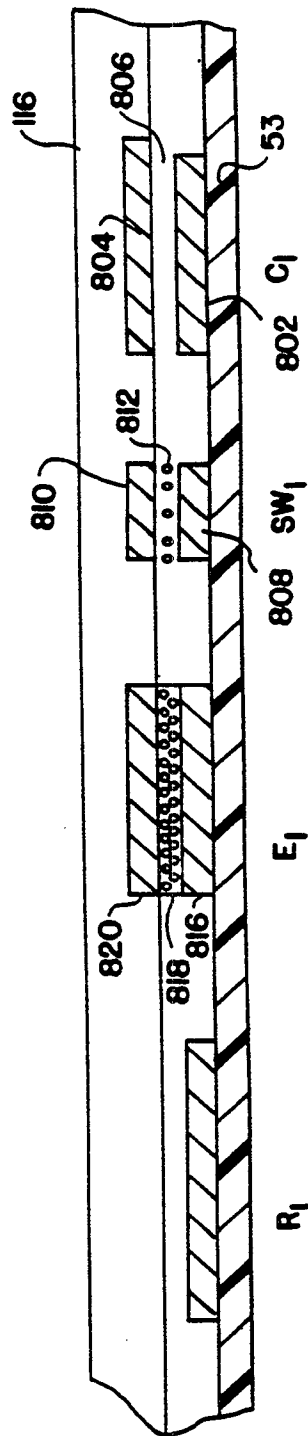

FIG. 8

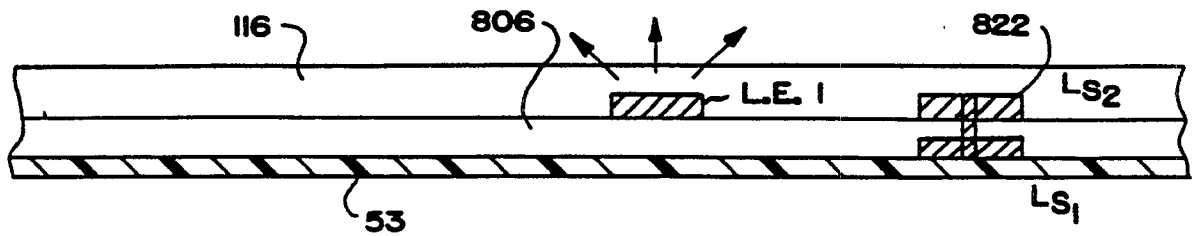

FIG. 9

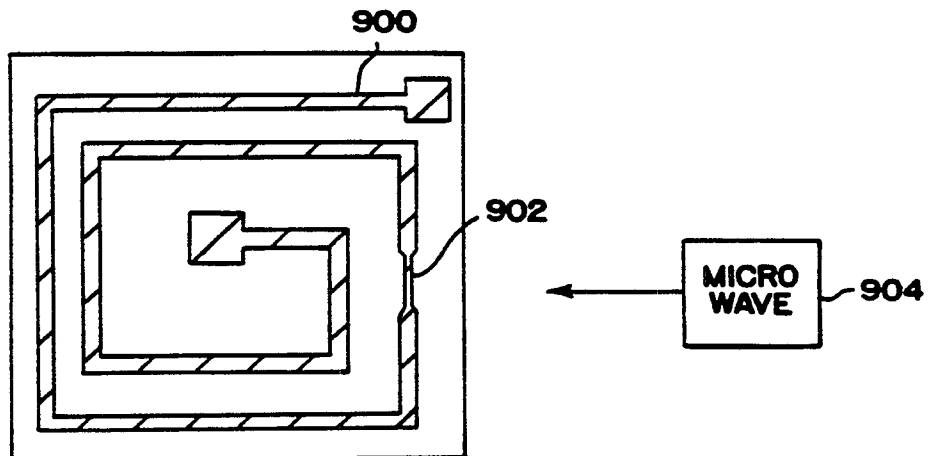

FIG. 10

