



(51) International Patent Classification:  
F25B 5/00 (2006.01)

(21) International Application Number:  
PCT/CN2014/094675

(22) International Filing Date:  
23 December 2014 (23.12.2014)

(25) Filing Language: English

(26) Publication Language: English

(71) Applicants: TRANE AIR CONDITIONING SYSTEMS (CHINA) CO., LTD. [CN/CN]; Suzhou Donglu No. 88, Taicang, Jiangsu 215400 (CN). TRANE INTERNATIONAL INC. [US/US]; One Centennial Avenue, Piscataway, New Jersey 08855 (US).

(72) Inventors: DU, Yuqing, Terry; 11F, Hongqiao City Tower Zunyi 100, Shanghai 200051 (CN). WANG, Jun, Jim; No. 268 Xi Zang Road, Shanghai 200001 (CN). XU, Liang; No. 268 Xi Zang Road, Shanghai 200001 (CN). DU, Mingxun, Max; Suzhou Donglu No. 88, Taicang, Jiangsu 215400 (CN).

(74) Agent: XU & PARTNERS, LLC.; Room No. 106, Building No. 1, Universal High-Tech Plaza, 958 Zhen Bei Road, Putuo District, Shanghai 200333 (CN).

(81) Designated States (unless otherwise indicated, for every kind of national protection available): AE, AG, AL, AM, AO, AT, AU, AZ, BA, BB, BG, BH, BN, BR, BW, BY, BZ, CA, CH, CL, CN, CO, CR, CU, CZ, DE, DK, DM, DO, DZ, EC, EE, EG, ES, FI, GB, GD, GE, GH, GM, GT, HN, HR, HU, ID, IL, IN, IR, IS, JP, KE, KG, KN, KP, KR, KZ, LA, LC, LK, LR, LS, LU, LY, MA, MD, ME, MG, MK, MN, MW, MX, MY, MZ, NA, NG, NI, NO, NZ, OM, PA, PE, PG, PH, PL, PT, QA, RO, RS, RU, RW, SA, SC, SD, SE, SG, SK, SL, SM, ST, SV, SY, TH, TJ, TM, TN, TR, TT, TZ, UA, UG, US, UZ, VC, VN, ZA, ZM, ZW.

(84) Designated States (unless otherwise indicated, for every kind of regional protection available): ARIPO (BW, GH, GM, KE, LR, LS, MW, MZ, NA, RW, SD, SL, ST, SZ, TZ, UG, ZM, ZW), Eurasian (AM, AZ, BY, KG, KZ, RU, TJ, TM), European (AL, AT, BE, BG, CH, CY, CZ, DE, DK, EE, ES, FI, FR, GB, GR, HR, HU, IE, IS, IT, LT, LU, LV, MC, MK, MT, NL, NO, PL, PT, RO, RS, SE, SI, SK, SM, TR), OAPI (BF, BJ, CF, CG, CI, CM, GA, GN, GQ, GW, KM, ML, MR, NE, SN, TD, TG).

Published:

— with international search report (Art. 21(3))

(54) Title: TEMPERATURE REGULATING SYSTEMS AND CONTROL METHODS THEREOF

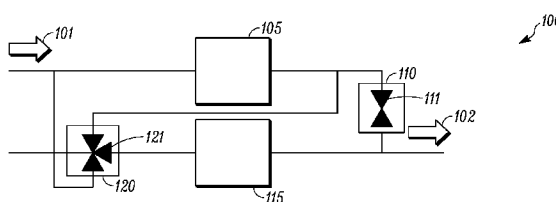

FIG. 1A

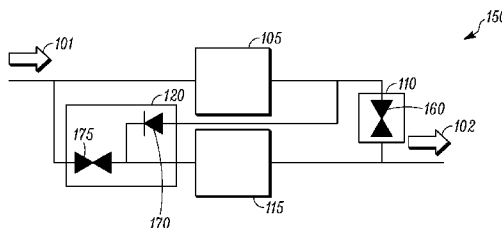

FIG. 1B

(57) Abstract: A temperature regulating system (100) includes a fluid circuit including fluidly connected components. The fluid circuit includes a first and second temperature regulator (105, 115), a first and second flow control device (110, 120), a fluid input (101), and a fluid output (102). The temperature regulating system (100) has the flexibility to position flow control devices (110, 120) such that the temperature regulators (105, 115) can be in parallel flow, serial flow, or combinations thereof.

## TEMPERATURE REGULATING SYSTEMS AND CONTROL METHODS THEREOF

### FIELD

The disclosure relates to temperature regulating systems and control methods thereof. More specifically, the disclosure relates to temperature regulating systems that include at least two temperature regulators and at least two flow control devices. The flow control devices can be in different positions, such that one temperature regulator may be in parallel and/or in serial flow with one or more other temperature regulators.

### BACKGROUND

A temperature regulator may be used to heat up or cool down a working fluid. A working fluid can be, e.g., water, refrigerant, or the like. Multiple temperature regulators may be used simultaneously to achieve a desired cooling or heating capacity.

### SUMMARY

The disclosure relates to temperature regulating systems and control methods thereof. More specifically, the disclosure relates to temperature regulating systems that includes at least two temperature regulators and at least two flow control devices. The flow control devices can be in different positions, such that one temperature regulator may be in parallel and/or in serial flow with one or more other temperature regulators.

A “position” of a flow control device is defined to be opening and/or closing of a certain fluid flow in a temperature regulating system. For example, when a flow control device is a two-way valve, the flow control device can be in a closed position that stops the fluid flow; or, the flow control device can be in an open position that allows the fluid flow. In another example, when a flow control device is a three-way valve having input-output ports A, B, and C, the flow control device can be in a position to stop the fluid flow at A and allow fluid flow between B and C; or, the flow control device can be in a position to stop the fluid flow at B and allow fluid flow between A and C; or the like.

A “flow” is defined to be a manner in which the working fluid flows through a temperature regulating system, e.g., in parallel flow, in serial flow, and/or combination thereof. For example, the working fluid may flow through two or more temperature regulators in parallel

flow. In another example, the working fluid may flow through two or more temperature regulators in serial flow.

A “connection” means the physical, structural connection of the components in a temperature regulating system. A certain connection of a temperature regulating system may allow for different fluid flows, e.g., parallel flow and/or serial flow, because flow control devices can change their positions.

This disclosure provides different embodiments of temperature regulating systems and control methods thereof, wherein the positions of the flow control devices in the temperature regulating system may be changed, so that the temperature regulators in the temperature regulating system may be in serial and/or in parallel flow. The disclosure provides different embodiments of temperature regulating systems that have the flexibility to change the fluid flow among parallel flow, serial flow, or combinations thereof.

To illustrate the advantages of the flexibilities according to the embodiments of the disclosure, consider the following example. One temperature regulating system does not have the flexibility to change fluid flow from parallel to serial flow. This temperature regulating system has two modular temperature regulators, for example two modular water chillers using water as a working fluid, are in parallel flow. A modular water chiller is a water chiller that can be added or removed from a system to increase or decrease the cooling capacity of the system, depending on the design and the need of the system. In one situation, the water flow is less than its maximum flow capacity, e.g., 50% of its maximum flow. In this situation, only one of the two temperature regulators, for example, can be operated, while the other unit is shut-off. This is because if both temperature regulators in parallel flow are simultaneously operated under a 50% fluid flow amount, damage to the temperature regulator units may result because of insufficient fluid flow. The use of only one of the two temperature regulators can result in a 50% of the cooling capacity of the system not being used, because the other regulator is not operating. However, if the temperature regulating system in this example has the flexibility to change the fluid flow such that the two temperature regulators in parallel flow can be changed to serial flow, then the cooling capacity of both temperature regulators can be used and, at the same time, potential damage to the temperature regulators due to insufficient fluid flow may be avoided.

This disclosure provides different temperature regulating systems and control methods thereof that provide the ability to change the fluid flow, e.g. in serial and/or in parallel flow, of

the temperature regulators. In other words, according to one embodiment, a temperature regulating system under a certain connection may have the compatibilities of parallel flow and/or serial flow. These compatibilities can be achieved through controls of the positions of flow control devices. For example, in one flow control device position, the temperature regulators may be in parallel flow. In another flow control device position, the temperature regulators may be in serial flow. In another flow control device position, the temperature regulators may be divided in groups; among groups, groups are in parallel flow; within each group, regulators are in serial flow.

In one embodiment, as an example, a temperature regulating system includes two temperature regulators and two flow control devices with a certain connection. Under the connection, when the fluid flow is at 100%, for example, the flow control devices can be in such a position that the two temperature regulators are in parallel flow. Under the same connection, when the fluid flow is at 50%, for example, the flow control devices can be in such a position that the two temperature regulators are in serial flow.

In another embodiment, as an example, a temperature regulating system includes three temperature regulators and four flow control devices with a certain connection. Under the connection, when the fluid flow is at 100%, for example, the flow control devices can be in such a position that the three temperature regulators are in parallel flow. Under the same connection, when the working fluid flow is at 33%, for example, the flow control device can be in such a position that the three temperature regulators are in serial flow.

In another embodiment, as an example, a temperature regulating system includes four temperature regulators and six flow control devices with a certain connection. Under the connection, when the fluid flow is at 100%, for example, the flow control devices can be in such a position that the four temperature regulators are in parallel flow. Under the same connection, when the working fluid flow is at 50%, for example, the flow control devices can be in such a position that the four temperature regulators are separated in two groups, group 1 and group 2, wherein group 1 and group 2 each includes two temperature regulators. Group 1 is in parallel flow with group 2. Yet, within each group, the two temperature regulators are in serial flow. Under the same connection, when the working fluid is at 25%, for example, the flow control devices can be in such a position that all four temperature regulators are in serial flow.

A “temperature regulator” may include at least one cooler, at least one heater, or combinations thereof. A cooler is to be understood as any apparatus that is capable of removing heat from a working fluid, such as water, oil, refrigerant, or the like, via heat exchanging. In one embodiment, a cooler is a chiller. In another embodiment, a cooler is a water chiller. In yet another embodiment, a cooler is a modular water chiller. A heater is to be understood as any apparatus that is capable of adding heat to a working fluid, such as water, oil, refrigerant, or the like, via heat exchanging. In one embodiment, the heater is a water heater. In another embodiment, the heater is a modular water heater.

In one embodiment the temperature regulating system can be used in radiation ceiling cooling, which uses, for example, water as a main working fluid. In another embodiment, the temperature regulating system can be used in radiant floor heating, which uses, for example, water as a main working fluid. In one embodiment, the temperature regulating system can be used in buildings and enclosed spaces and/or rooms, such as for example a hotel, a hospital, a school, an apartment building, a shopping mall, a conference center, a residential home, a sports stadium, or the like.

The disclosure provides a temperature regulating system includes a total number of  $N$  temperature regulators, each temperature regulator is expressed as the  $i$ th temperature regulator, where  $i = 1, 2, 3, 4 \dots N$ ;  $N$  can be any positive integer  $\geq 2$ . The fluid circuit further includes a total number of  $(2N - 2)$  flow control devices, a fluid input, and a fluid output.

For example, in one embodiment, a temperature regulating system includes a fluid circuit including fluidly connected components. The fluid circuit includes a first and second temperature regulator, a first and second flow control device, a fluid input, and a fluid output. In the fluid circuit, the fluid input is disposed upstream of the first temperature regulator, and upstream of the second flow control device. The fluid output is disposed downstream of the first flow control device, and downstream of the second temperature regulator. The first temperature regulator is disposed downstream of the fluid input, upstream of the first flow control device, and upstream of the second flow control device. The second temperature regulator is disposed downstream of the second flow control device, and upstream of the fluid output. The first flow control device is disposed downstream of the first temperature regulator, and upstream of the fluid output. The second flow control device is disposed downstream of the fluid input, downstream of the first temperature regulator, and upstream of the second temperature regulator.

A “flow control device” may include one or more devices for controlling fluid flow, for example, one or more valves. A flow control device is to be understood to be any combination of flow control devices, e.g., valves, that are able to establish a suitable fluid flow. For example, in one embodiment, a flow control device includes a two-way valve. In one embodiment, a flow control device includes a three-way valve. In another embodiment, a flow control device includes a check valve and a two-way valve.

Flow control devices in a temperature regulating system may include different devices. In one embodiment, within a temperature regulating system, one flow control device is a two-way valve and another flow control device is a three-way valve. In another embodiment, within a temperature regulating system, one flow control device is a two-way valve and another flow control device is a combination of a check valve and a two-way valve.

One embodiment of a method of controlling a temperature regulating system includes, receiving information about an amount, e.g. flow rate, of a working fluid flowing into the system; determining a target temperature of the working fluid; and determining an operation of the temperature regulating system to obtain the target temperature of the working fluid. Determining an operation of the temperature regulating system further includes, when the fluid amount is less than a threshold amount, positioning a flow control device such that at least two temperature regulators in the temperature regulating system are in serial flow.

A “threshold amount” is defined to be a certain amount of fluid, e.g. flow rate, flowing into a temperature regulating system that is sufficient to support a certain number of temperature regulators in the system to operate in a parallel flow without being damaged due to insufficient fluid flow. In some situations, the certain number of temperature regulators means all of the temperature regulators in the system. In some situations, the certain number of temperature regulators means less than all of the temperature regulators in the system.

In one embodiment, a temperature regulating system has four regulators and each regulator requires 25% of a maximum fluid flow supply to avoid being damaged due to insufficient fluid flow. In a first situation of the embodiment, the four regulators are all in parallel flow. In the first situation, the threshold amount is 100% of the maximum fluid flow supply. In a second situation of the embodiment, the four regulators are separated into two groups (e.g., group 1 and group 2). Within each group, the temperature regulators are in serial flow. Among the two groups, the groups are in parallel flow. In this second situation, the

threshold amount is 50% of the maximum fluid flow supply. In a third situation, the four regulators are all in serial flow. In this third situation, the threshold amount is 25% of the maximum fluid flow supply. In one embodiment, the threshold amount can be predetermined by testing the system.

#### BRIEF DESCRIPTION OF THE DRAWINGS

FIG. 1A illustrates one embodiment of a temperature regulating system with two temperature regulators and two flow control devices.

FIG. 1B illustrates another embodiment of a temperature regulating system with two temperature regulators and two flow control devices.

FIG. 2A illustrates one embodiment of a temperature regulating system with three temperature regulators and four flow control devices.

FIG. 2B illustrates another embodiment of a temperature regulating system with three temperature regulators and four flow control devices.

FIG. 3A illustrates one embodiment of a temperature regulating system with four temperature regulators and six flow control devices.

FIG. 3B illustrates another embodiment of a temperature regulating system with four temperature regulators and six flow control devices.

FIG. 4 illustrates an embodiment of a control method of a temperature regulating system.

FIG. 5 illustrates one embodiment of a temperature regulating system with one controller, two temperature regulators, and two flow control devices.

#### DETAILED DESCRIPTION

The term “upstream of” and “downstream of” indicates the relative locations in a fluid flow direction in a fluid circuit which include fluidly connected components. Fluid flows from upstream to downstream. For example, component A is disposed downstream of component B means fluid flows from component B to component A. In another example, component A is disposed downstream of component B has the same meaning as B is disposed upstream of A. In this paragraph, component means non-piping and non-passage way types of system components, e.g., temperature regulators, flow control devices, oil separators, heat-exchangers, or the like. In some embodiments, “disposed downstream” (or upstream) means fluid can flow directly from

one component to another component directly without any intermediate component disposed in between. For example, component A is disposed downstream of component B means fluid flows directly from B to A without any intermediate component between component B and component A. In some other embodiments, “disposed downstream” (or upstream) means fluid can flow indirectly from one component to another component with intermediate components disposed in between. For example, component A is disposed downstream of component B means fluid flows indirectly from B to A with one or more intermediate components disposed between component B and component A.

FIG. 1A and 1B illustrates two different embodiments of a temperature regulating system with two temperature regulators and two flow control devices. A flow control device may include one or more devices for controlling fluid flow, for example, one or more valves. A flow control device is to be understood to be any combination of devices, e.g., valves, that is able to establish a suitable fluid flow. For example, in one embodiment, a flow control device includes a two-way valve. In one embodiment, a flow control device includes a three-way valve. In another embodiment, a flow control device includes a check valve and a two-way valve.

FIG. 1A illustrates one embodiment of a temperature regulating system 100 with two temperature regulators and two flow control devices. In FIG. 1A, one embodiment of a temperature regulating system 100 includes a fluid circuit including fluidly connected components. The fluid circuit includes a first 105 and second 115 temperature regulator, a first 110 and second 120 flow control device, a fluid input 101, and a fluid output 102.

In the fluid circuit, the fluid input 101 is disposed upstream of the first temperature regulator 105, and upstream of the second flow control device 120. The fluid output 102 is disposed downstream of the first flow control device 110, and downstream of the second temperature regulator 115.

The first temperature regulator 105 is disposed downstream of the fluid input 101, upstream of the first flow control device 110, and upstream of the second flow control device 120. The second temperature regulator is disposed downstream of the second flow control device 120, and upstream of the fluid output 102.

The first flow control device 110 is disposed downstream of the first temperature regulator 105, and upstream of the fluid output 102. The second flow control device 120 is disposed downstream of the fluid input 101, downstream of the first temperature regulator 105,

and upstream of the second temperature regulator 115. As shown in FIG. 1A, the first flow control device 110 is a two-way valve 111. The second flow control device 120 is a three-way valve 121.

FIG. 1B illustrates another embodiment of a temperature regulating system 100 with two temperature regulators and two flow control devices. As shown in FIG. 1B, the first flow control device 110 can be a two-way valve 160. In another embodiment, the second flow control device 120 can include a check valve 170 and a two-way valve 175. The check valve 170 is disposed downstream of the first temperature regulator 105 and upstream of the second temperature regulator 115. The check valve 170 regulates fluid to flow unidirectionally from the first temperature regulator 105 to the second temperature regulator 115. The two-way valve 175 is disposed downstream of the fluid input 101 and upstream of the second temperature regulator 115.

In one embodiment, as shown in FIG. 1A and 1B, the first flow control device 110 and the second flow control device 120 can be in a position such that the first temperature regulator 105 and the second temperature regulator 115 can be in parallel flow. The first flow control device 110 can be in an open position, such that the working fluid can flow, e.g. flow directly, from the first temperature regulator 105 to the fluid output 102. The second flow control device 120 is in a position such that no working fluid can flow from the first temperature regulator 105 to the second temperature regulator 115; and there can be fluid flow, e.g. direct flow, from the fluid input 101 to the second temperature regulator 115.

In another embodiment, as shown in FIG. 1A and 1B, the first flow control device 110 and the second flow control device 120 can be in a position such that the first temperature regulator 105 and the second temperature regulator 115 can be in serial flow. The first flow control device 110 can be in a closed position, such that the working fluid cannot flow from the first temperature regulator 105 to the fluid output 102. The second flow control device 120 is in a position such that working fluid can flow, e.g. flow directly, from the first temperature regulator 105 to the second temperature regulator 115; and no fluid can flow from the fluid input 101 to the second temperature regulator 115.

In one embodiment, the first 105 and/or second 115 temperature regulator may include at least one cooler, at least one heater, or combinations thereof. A cooler is to be understood as any apparatus that is capable of removing heat from a liquid via heat exchanging. In one

embodiment, a cooler is a chiller. In another embodiment, a cooler is a water chiller. In yet another embodiment, a cooler is a modular water chiller. A heater is to be understood as any apparatus that is capable of adding heat to a liquid via heat exchanging. In one embodiment, the heater is a water heater. In another embodiment, the heater is a modular water heater.

FIG. 2A illustrates one embodiment of a temperature regulating system 200 with three temperature regulators and four flow control devices. In one embodiment, as shown in FIG. 2A, a temperature regulating system 200 includes a fluid circuit including fluidly connected components. The fluid circuit includes a first 205, second 220, and third 235 temperature regulator, a first 210, second 215, third 225, and fourth 230 flow control device, a fluid input 201, and a fluid output 202.

The fluid input 201 is disposed upstream of the first temperature regulator 205, upstream of the second 215 and fourth 230 flow control devices. The fluid output 202 is disposed downstream of the first 210 and third 225 flow control devices, and downstream of the third temperature regulator 235.

The first temperature regulator 205 is disposed downstream of the fluid input 201, upstream of the first flow control device 210, and upstream of the second flow control device 215. The second temperature regulator 220 is disposed downstream of the second flow control device 215, upstream of the third flow control device 225, and upstream of the fourth flow control device 230. The third temperature regulator 235 is disposed downstream of the fourth flow control device 230, and upstream of the fluid output 202.

The first flow control device 210 is disposed downstream of the first temperature regulator 205, and upstream of the fluid output 202. The second flow control device 215 is disposed downstream of the fluid input 201, downstream of the first temperature regulator 205, and upstream of the second temperature regulator 220. The third flow control device 225 is disposed downstream of the second temperature regulator 220, and upstream of the fluid output 202. The fourth flow control device 230 is disposed downstream of the fluid input 201, downstream of the second temperature regulator 220, and upstream of the third temperature regulator 235.

As shown in FIG. 2A and FIG. 2B, in one embodiment, the first flow control device 210 can be a two-way valve 211. In one embodiment, the third flow control device 225 can be a two-way valve 226.

As shown in FIG. 2A, in one embodiment, the second flow control device 215 can be a three-way valve 216. In another embodiment, the fourth flow control device 230 can be a three-way valve 231.

As shown in FIG. 2B, in one embodiment, the second flow control device 215 can include a check valve 218 and a two-way valve 217. The check valve 218 is disposed downstream of the first temperature regulator 205 and upstream of the second temperature regulator 220. The check valve 218 regulates fluid to flow unidirectionally from the first temperature regulator 205 to the second temperature regulator 220. The two-way valve 217 is disposed downstream of the fluid input 201 and upstream of the second temperature regulator 220.

As shown in FIG. 2B, the fourth flow control device 230 can include a check valve 233 and a two-way valve 232. The check valve 233 is disposed downstream of the second temperature regulator 220 and upstream of the third temperature regulator 235. The check valve 233 regulates fluid to flow unidirectionally from the second temperature regulator 220 to the third temperature regulator 235. The two-way valve 232 is disposed downstream of the fluid input 201 and upstream of the third temperature regulator 235.

In one embodiment, the flow control devices 210, 215, 225, 230 are in a position such that the temperature regulators 205, 220, 235 (as show in FIG. 2A and 2B) are in parallel flow. In this embodiment, the first 210 and the third 225 flow control devices are in open positions, such that working fluid can flow, e.g. flow directly, from the first 205 and the second 220 temperature regulators to the fluid output 202. In this embodiment, the second flow control device 215 is in a position that there is no flow of working fluid from the first temperature regulator 205 to the second temperature regulator 220; but there is flow, e.g. direct flow, of working fluid from the fluid input 201 to the second temperature regulator 220. In this embodiment, the fourth flow control device 230 is in a position that there is no flow of working fluid from the second temperature regulator 220 to the third temperature regulator 235; but there is flow, e.g. direct flow, of working fluid from the fluid input 201 to the third temperature regulator 235. In another embodiment, the flow control devices 210, 215, 225, 230 are in a position such that the temperature regulators 205, 220, 235 (as show in FIG. 2A and 2B) are in serial flow. In this embodiment, the first 210 and the third 225 flow control devices are in closed positions, such that working fluid cannot flow from the first 205 and the second 220 temperature

regulators to the fluid output 202. In this embodiment, the second flow control device 215 is in a position such that the working fluid can flow, e.g. flow directly, from the first temperature regulator 205 to the second temperature regulator 220; but the working fluid cannot flow from the fluid input 201 to the second temperature regulator 220. In this embodiment, the fourth flow control device 230 is in a position such that the working fluid can flow, e.g. flow directly, from the second temperature regulator 220 to the third temperature regulator 235; but there the working fluid cannot flow from the fluid input 201 to the third temperature regulator 235.

In another embodiment, the flow control devices 210, 215, 225, 230 are in a position such that the temperature regulators 205, 220, 235 (as show in FIG. 2A and 2B) are separated in two groups, group 1 and group 2. Group 1 and group 2 are in parallel flow. However, within each group, the temperature regulators are in serial flow.

In one embodiment, as shown in FIG. 2A and 2B, group 1 may include the first 205 and second 220 temperature regulators, wherein the first 205 and second 220 temperature regulators may be in serial flow. Group 2 includes the third temperature regulator 235. In this embodiment, the first flow control device 210 is in a closed position, such that working fluid cannot flow from the first temperature regulator 205 to the fluid output 202. The second flow control device 215 is in a position such that the working fluid can flow, e.g. flow directly, from the first temperature regulator 205 to the second temperature regulator 220, but the working fluid cannot flow from the fluid input 201 to the second temperature regulator 220. The third flow control device 225 is in an open position, such that working fluid can flow, e.g. flow directly, from the second temperature regulator 220 to the fluid output 202. The fourth flow control device 230 is in a position such that the working fluid cannot flow from the second temperature regulator 220 to the third temperature regulator 235, but the working fluid can flow, e.g. flow directly, from the fluid input 201 to the third temperature regulator 235.

In one embodiment, the first 205, second 220, and/or third 235 temperature regulator may include at least one cooler, at least one heater, or combinations thereof. A cooler is to be understood as any apparatus that is capable of removing heat from a liquid via heat exchanging. In one embodiment, a cooler is a chiller. In another embodiment, a cooler is a water chiller. In yet another embodiment, a cooler is a modular water chiller. A heater is to be understood as any apparatus that is capable of adding heat to a liquid via heat exchanging. In one embodiment, the heater is a water heater. In another embodiment, the heater is a modular water heater.

FIG. 3A illustrates one embodiment of a temperature regulating system 300 with four temperature regulators and six flow control devices. In one embodiment, such as in FIG. 3A, a temperature regulating system 300, includes a fluid circuit including fluidly connected components. The fluid circuit includes a first 305, second 320, third 335, and fourth 349 temperature regulator, a first 310, second 315, third 325, fourth 330, fifth 340, and sixth 345 flow control device, a fluid input 301, and a fluid output 302.

In the temperature regulating system 300, the fluid input 301 is disposed upstream of the first temperature regulator 305, and upstream of the second 316, fourth 331, and sixth 346 flow control devices.

The fluid output 302 is disposed downstream of the first 310, third 325, and fifth 340 flow control devices, and downstream of the fourth temperature regulator 349.

The first temperature regulator 305 is disposed downstream of the fluid input 301, upstream of the first flow control device 310, and upstream of the second flow control device 315. The second temperature regulator 320 is disposed downstream of the second flow control device 315, upstream of the third flow control device 325, and upstream of the fourth flow control device 330. The third temperature regulator 335 is disposed downstream of the fourth flow control device 330, upstream of the fifth flow control device 340, and upstream of the sixth flow control device 345. The fourth temperature regulator 349 is disposed downstream of the sixth flow control device 345, and upstream of the fluid output 302.

The first flow control device 310 is disposed downstream of the first temperature regulator 305, and upstream of the fluid output 302. The second flow control device 315 is disposed downstream of the fluid input 301, downstream of the first temperature regulator 305, and upstream of the second temperature regulator 320. The third flow control device 325 is disposed downstream of the second temperature regulator 320, and upstream of the fluid output 302. The fourth flow control device 330 is disposed downstream of the fluid input 301, downstream of the second temperature regulator 320, and upstream of the third temperature regulator 335. The fifth flow control device 340 is disposed downstream of the third temperature regulator 335, and upstream of the fluid output 302. The sixth flow control device 345 is disposed downstream of the fluid input 301, downstream of the third temperature regulator 335, and upstream of the fourth temperature regulator 349.

In one embodiment, as shown in FIG. 3A and FIG. 3B, the first flow control device 310 is a two-way valve 311. In another embodiment, the third flow control device 325 can be a two-way valve 326. In yet another embodiment, the fifth flow control device 340 can be a two-way valve 341.

In one embodiment, as shown in FIG. 3A, the second flow control device 315 can be a three-way valve 316. In another embodiment, the fourth flow control device 330 can be a three-way valve 331. In another embodiment, the sixth flow control device 345 can be a three-way valve 346.

As shown in FIG. 3B, in one embodiment, the second flow control device 315 can include a check valve 318 and a two-way valve 317. The check valve 318 is disposed downstream of the first temperature regulator 305 and upstream of the second temperature regulator 320. The check valve 318 regulates fluid to flow unidirectionally from the first temperature regulator 305 to the second temperature regulator 320. The two-way valve 317 is disposed downstream of the fluid input 301 and upstream of the second temperature regulator 320.

As shown in FIG. 3B, in another embodiment, the fourth flow control device 330 can include a check valve 333 and a two-way valve 332. The check valve 333 is disposed downstream of the second temperature regulator 320 and upstream of the third temperature regulator 335. The check valve 333 regulates fluid to flow unidirectionally from the second temperature regulator 320 to the third temperature regulator 335. The two-way valve 332 is disposed downstream of the fluid input 301 and upstream of the third temperature regulator 335.

As shown in FIG. 3B, in another embodiment, the sixth flow control device 345 can include a check valve 348 and a two-way valve 347. The check valve 348 is disposed downstream of the third temperature regulator 335 and upstream of the fourth temperature regulator 349. The check valve 348 regulates fluid to flow unidirectionally from the third temperature regulator 335 to the fourth temperature regulator 349. The two-way valve 347 is disposed downstream of the fluid input 301 and upstream of the fourth temperature regulator 349.

In one embodiment, the first 305, second 320, third 335, and/or fourth 349 temperature regulator may include at least one cooler, at least one heater, or combinations thereof. A cooler is to be understood as any apparatus that is capable of removing heat from a liquid via heat exchanging. In one embodiment, a cooler is a chiller. In another embodiment, a cooler is a

water chiller. In yet another embodiment, a cooler is a modular water chiller. A heater is to be understood as any apparatus that is capable of adding heat to a liquid via heat exchanging. In one embodiment, the heater is a water heater. In another embodiment, the heater is a modular water heater.

Applying similar principles as described in FIG. 1A, 1B, 2A, and 2B, in one embodiment, the first 310, second 315, third 325, fourth 330, fifth 340, and sixth 345 flow control devices may be in a position that the first 305, second 320, third 335, and fourth 349 temperature regulators are in serial flow. In one embodiment, the first 310, second 315, third 325, fourth 330, fifth 340, and sixth 345 flow control devices may be in a position that the first 305, second 320, third 335, and fourth 349 temperature regulators are in parallel flow.

In another embodiment, the flow control devices 310, 315, 325, 330, 340, 345 are in a position such that the temperature regulators 305, 320, 335, 349 (as show in FIG. 3A and 3B) are separated in two groups, group 1 and group 2. Group 1 and group 2 are in parallel flow. However, within each group, the temperature regulators are in serial flow.

In one embodiment, as shown in FIG. 3A and 3B, group 1 may include the first 305 and second 320 temperature regulators, wherein the first 305 and second 320 temperature regulators may be in serial flow. Group 2 includes the third 335 and fourth 349 temperature regulators, wherein the third 335 and the fourth 349 temperature regulators may be in serial flow. In this embodiment, the first flow control device 310 is in a closed position, such that working fluid cannot flow from the first temperature regulator 305 to the fluid output 302. The second flow control device 315 is in a position such that the working fluid can flow, e.g. flow directly, from the first temperature regulator 305 to the second temperature regulator 320, but the working fluid cannot flow from the fluid input 301 to the second temperature regulator 320. The third flow control device 325 is in an open position, such that the working fluid can flow, e.g. flow directly, from the second temperature regulator 320 to the fluid output 302. The fourth flow control device 330 is in a position such that the working fluid cannot flow from the second temperature regulator 320 to the third temperature regulator 335, but the working fluid can flow, e.g. flow directly, from the fluid input 301 to the third temperature regulator 335. The fifth flow control device 340 is in a closed position, such that working fluid cannot flow from the third temperature regulator 335 to the fluid output 302. The sixth flow control device 345 is in a position such that the working fluid can flow, e.g. flow directly, from the third temperature regulator 335 to the

fourth temperature regulator 349, but the working fluid cannot flow from the fluid input 301 to the fourth temperature regulator 349. It should be understood that the above embodiment is only an example. Group 1 and group 2 may include different number of temperature regulators, e.g., group 1 has three and group 2 has one temperature regulator, or vice versa, and still maintain the parallel flow among groups and serial flow within a group.

It should be understood that different embodiments of a temperature regulating system are not limited to two regulators (as shown in FIG. 1A and 1B), three regulators (as shown in FIG. 2A and 2B), and four regulators (as shown in FIG. 3A and 3B). The number of regulators can go up to  $N$ , where  $N$  can be any positive integer equal or larger than 2.

In one embodiment, a temperature regulating system includes a fluid circuit including fluidly connected components. The fluid circuit includes a total number of  $N$  temperature regulators, each temperature regulator is expressed as the  $i$ th temperature regulator, where  $i = 1, 2, 3, 4 \dots N$ ;  $N$  can be any positive integer  $\geq 2$ . The fluid circuit further includes a total number of  $(2N - 2)$  flow control devices, a fluid input, and a fluid output.

The configurations of the  $N$  regulators and the  $(2N - 2)$  flow control devices can be mathematically described under three conditions: when  $i = 1$ ,  $1 < i < N$ , and  $i = N$  as follows.

When  $i = 1$ , the  $i$ th temperature regulator is disposed downstream of the fluid input, upstream of the  $(2i - 1)$ th flow control device, and upstream of the  $(2i)$ th flow control device; the  $(2i - 1)$ th flow control device is disposed downstream to the  $i$ th temperature regulator, and upstream of the fluid output, the  $(2i)$ th flow control device is disposed downstream of the fluid input, downstream of the  $i$ th temperature regulator, and upstream of the  $(i + 1)$ th temperature regulator.

When  $1 < i < N$ , the  $i$ th temperature regulator is disposed downstream of the  $(2i - 2)$ th flow control device, upstream of the  $(2i - 1)$ th flow control device, and upstream of the  $(2i)$ th flow control device; the  $(2i - 1)$ th flow control device is disposed downstream of the  $i$ th temperature regulator, and upstream of the fluid output, the  $(2i)$ th flow control device is disposed downstream to the fluid input, downstream of the  $i$ th temperature regulator, and upstream of the  $(i + 1)$ th regulator.

When  $i = N$ , the  $i$ th temperature regulator is disposed downstream of the  $(2i - 2)$ th flow control device, and upstream of the fluid output.

In another embodiment, for example, a temperature regulating system with N regulators and  $(2N-2)$  flow control devices, the flow control devices may be in different positions such that any temperature regulator can be in a parallel and/or serial flow with another temperature regulator.

FIG. 4 illustrates an embodiment of a control method 400 of a temperature regulating system. In one embodiment, as shown in FIG. 4, the control method includes receiving information about an amount of a working fluid flowing into the system 405; determining a target temperature of the working fluid 410; and determining an operation of the temperature regulating system to obtain the target temperature of the working fluid 415. The determining an operation of the temperature regulating system further includes, when the fluid amount is less than a threshold amount, positioning a flow control device such that at least two temperature regulators in the temperature regulating system are in serial flow 420.

The method of receiving information about an amount of a working fluid flowing into the system further includes receiving information about working fluid availability 406; and/or receiving information about demands of the working fluid 407.

The receiving information about working fluid availability 406 may further include receiving information about the working fluid supply; receiving information about a governmental regulation; or the like. The receiving information about the working fluid supply can include measuring the fluid flow amount at a fluid input. The receiving information about a governmental regulation may include e.g, information about municipal water control schedule, limitation on water usage, or the like.

The receiving information about demands of the working fluid 407 may further include receiving information about a predictable schedule. Predictable schedule may include, e.g., a check-in, check-out schedule of a hotel, a meeting schedule of a conference, a working schedule of a factory, a class schedule of a school, a working schedule of an office building, an operational schedule of a shopping mall, or the like.

The determining a target temperature of the working fluid 410 may further include receiving information about a fluid temperature at a fluid input 411; receiving information about a fluid temperature at a fluid output 412; receiving information about indoor temperature 413; receiving information about outdoor temperature 414; and/or the like. The outdoor temperature may be obtained through actual measurement, weather forecast, or the like.

The determining an operation of the temperature regulating system 415 may include receiving information of a working load of the temperature regulator 416, e.g., compressor energy consumptions, fan speed, working fluid flow rate, fluid pump energy consumptions, and/or the like. The determining an operation of the temperature regulating system 415 may further include a subsequent process of regulating a cooling/heating capacity of the temperature regulators 417, or the like.

FIG. 5 illustrates one embodiment of a temperature regulating system with one controller, two temperature regulators, and two flow control devices. In FIG. 5, the temperature regulating system 500 includes a first 510 and second 520 temperature regulator, a first 514 and second 524 flow control device, a fluid input 501, a fluid output 502, and a controller 505.

As shown in FIG. 5, the controller 505 establishes independent communications (shown as dashed line) with the first temperature regulator 510, the second temperature regulator 520, the first flow control device 514, and the second flow control device 524. The communication can be electrical/electromagnetic/electronic communication. In one embodiment, the communication can be done through a physical wire. In another embodiment, the communication can be done through wireless communication. The controller 505 may include a processor, a memory, a clock, and an input/output (I/O) interface (not shown). In some embodiments, the controller can include fewer or additional components.

In one embodiment, the controller 505 may control the working capacity of the temperature regulators 510, 520.

In one embodiment, the controller 505 may control the first 514 and the second 524 flow control devices in a position such that the first 510 and second 520 temperature regulators are in serial flow. In this embodiment, the controller 505 controls the first flow control device 514 in a position such that no fluid flows from the first temperature regulator 510 to the fluid output 502. The controller 505 further controls the second flow control device 524 such that no working fluid may flow from the fluid input 501 to the second temperature regulator 520, but the working fluid may flow, e.g., directly flow, from the first temperature regulator 510 to the second temperature regulator 520.

In one embodiment, the controller 505 may control the first 514 and the second 524 flow control devices in a position that the first 510 and second 520 temperature regulators are in parallel flow. In this embodiment, the controller 505 controls the first flow control device 514

such that the working fluid may flow, e.g., directly flow, from the first temperature regulator 510 to the fluid output 502. The controller 505 further controls the second flow control device 524 such that the working fluid may flow, e.g., directly flow, from the fluid input 501 to the second temperature regulator 520, but the working fluid cannot flow from the first temperature regulator 510 to the second temperature regulator 520.

It is to be understood that the controller 505 described in FIG. 5 can be applied to any temperature regulating system described in this application, for example FIG. 1A, 1B, 2A, 2B, 3A, and 3B. It is to be understood that a controller may be further applied in a temperature regulating system with N regulators, where N is positive integers and  $N \geq 2$ , and (2N-2) flow control devices. The controller can be used in a temperature regulating system to change positions of flow control devices, such that the fluid flows of the temperature regulators are changeable, e.g. parallel, serial, parallel among groups and serial within any group, or the like. Examples of the flexibility of changing fluid flows are described in different embodiments in FIG. 1A, 1B, 2A, 2B, 3A, and 3B.

It is to be understood that a controller can be applied to any temperature regulating system using the control method as shown in FIG. 4. A controller 505 may receive information about a fluid amount of a working fluid 405; may determine a target temperature of the working fluid 410; and determine an operation of the temperature regulating system 415. The controller 505 may also determine the operation, when the fluid amount is less than a threshold amount, the controller can position a flow control device such that at least two temperature regulators in the temperature regulating system are in serial flow 420.

Aspects.

It is noted that any of the aspects 1-16, and be combined with any of the aspects 16 and 17-22. Aspect 16 can be combined with any of the aspects 17-22.

Aspect 1. A temperature regulating system, comprising:

a fluid circuit including fluidly connected components, the fluid circuit includes a first and second temperature regulator, a first and second flow control device, a fluid input, and a fluid output, wherein,

the fluid input is disposed upstream of the first temperature regulator, and upstream of the second flow control device;

the fluid output is disposed downstream of the first flow control device, and downstream of the second temperature regulator;

the first temperature regulator is disposed downstream of the fluid input, upstream of the first flow control device, and upstream of the second flow control device;

the second temperature regulator is disposed downstream of the second flow control device, and upstream of the fluid output;

the first flow control device is disposed downstream of the first temperature regulator, and upstream of the fluid output; and

the second flow control device is disposed downstream of the fluid input, downstream of the first temperature regulator, and upstream of the second temperature regulator.

Aspect 2. The temperature regulating system according to aspect 1, the first flow control device includes a two-way valve.

Aspect 3. The temperature regulating system according to aspect 1-2, the second flow control device includes a three-way valve.

Aspect 4. The temperature regulating system according to aspect 1-2, the second flow control device further includes a check valve and a two-way valve, wherein,

the check valve is disposed downstream of the first temperature regulator and upstream of the second temperature regulator, the check valve regulates fluid to flow unidirectionally from the first temperature regulator to the second temperature regulator; and

the two-way valve is disposed downstream of the fluid input and upstream of the second temperature regulator,

Aspect 5. The temperature regulating system according to aspect 1-4, wherein the first or second temperature regulator includes at least one cooler or at least one heater.

Aspect 6. The temperature regulating system according to aspect 1-5, further includes a controller, the controller controls the temperature regulators and flow control devices.

Aspect 7. The temperature regulating system according to aspect 1-6, wherein the fluid circuit further comprises a third temperature regulator, and a third and fourth flow control device, wherein,

the third temperature regulator is disposed downstream of the fourth flow control device, and upstream of the fluid output;

the third flow control device is disposed downstream of the second temperature regulator, and upstream of the fluid output; and

the fourth flow control device is disposed downstream of the fluid input, downstream of the second temperature regulator, and upstream of the third temperature regulator.

Aspect 8. The temperature regulating system according to aspect 7, the third flow control device includes a two-way valve.

Aspect 9. The temperature regulating system according to aspect 7-8, the fourth flow control device includes a three-way valve.

Aspect 10. The temperature regulating system according to aspect 7-8, the fourth flow control device further includes a check valve and a two-way valve, wherein,

the check valve is disposed downstream of the second temperature regulator and upstream of the third temperature regulator, the check valve regulates fluid to flow unidirectionally from the second temperature regulator to the third temperature regulator; and

the two-way valve is disposed downstream of the fluid input and upstream of the third temperature regulator.

Aspect 11. The temperature regulating system according to aspect 7-10, the third temperature regulator includes at least one cooler or at least one heater.

Aspect 12. The temperature regulating system according to aspect 7-11, wherein the fluid circuit further comprises a fourth temperature regulator, and a fifth and sixth flow control device, wherein,

the fourth temperature regulator is disposed downstream of the sixth flow control device, and upstream of the fluid output;

the fifth flow control device is disposed downstream of the third temperature regulator, and upstream of the fluid output; and

the sixth flow control device is disposed downstream of the fluid input, downstream of the third temperature regulator, and upstream of the fourth temperature regulator.

Aspect 13. The temperature regulating system according to aspect 12, the fifth flow control device includes a two-way valve.

Aspect 14. The temperature regulating system according to aspect 12-13, the sixth flow control device includes a three-way valve.

Aspect 15. The temperature regulating system according to aspect 12-13, the sixth flow control device further includes a check valve and a two-way valve, wherein,

the check valve is disposed downstream of the third temperature regulator and upstream of the fourth temperature regulator, the check valve regulates fluid to flow unidirectionally from the third temperature regulator to the fourth temperature regulator; and

the two-way valve is disposed downstream of the fluid input and upstream of the fourth temperature regulator.

Aspect 16. A temperature regulating system, comprising:

a fluid circuit including fluidly connected components, the fluid circuit includes a total number of  $i$  temperature regulators, where  $i = 1, 2, 3, 4 \dots N; N$  can be any positive integer  $\geq 2$ , a total number of  $(2N - 2)$  flow control devices, a fluid input, and a fluid output,

wherein,

when  $i = 1$ ,

the  $i$ th temperature regulator is disposed downstream of the fluid input, upstream of the  $(2i - 1)$ th flow control device, and upstream of the  $(2i)$ th flow control device;

the  $(2i - 1)$ th flow control device is disposed downstream to the  $i$ th temperature regulator, and upstream of the fluid output,

the  $(2i)$ th flow control device, where is disposed downstream of the fluid input, downstream of the  $i$ th temperature regulator, and upstream of the  $(i + 1)$ th temperature regulator,

when  $1 < i < N$ ,

the  $i$ th temperature regulator is disposed downstream of the  $(2i - 2)$ th flow control device, upstream of the  $(2i - 1)$ th flow control device, and upstream of the  $(2i)$ th flow control device,

the  $(2i - 1)$ th flow control device is disposed downstream of the  $i$ th temperature regulator, and upstream of the fluid output,

the  $(2i)$ th flow control device is disposed downstream to the fluid input, downstream of the  $i$ th temperature regulator, and upstream of the  $(i + 1)$ th regulator;

when  $i = N$ ,

the  $i$ th temperature regulator is disposed downstream of the  $(2i - 2)$ th flow control device, and upstream of the fluid output.

Aspect 17. A method of controlling a temperature regulating system, comprising,

receiving information about an amount of a working fluid flowing into the system;

determining a target temperature of the working fluid; and

determining an operation of the temperature regulating system to obtain the target temperature of the working fluid, further including

when the fluid amount is less than a threshold amount, positioning a flow control device such that at least two temperature regulators in the temperature regulating system are in serial flow.

Aspect 18. The method of aspect 17, wherein the step of receiving information about a fluid amount of a working fluid comprises

- receiving information about working fluid availability; and/or
- receiving information about demands of the working fluid

Aspect 19. The method of aspect 18, wherein the step of receiving information about working fluid availability includes

- receiving information about the working fluid supply; and/or
- receiving information about a governmental regulation.

Aspect 20. The method of aspect 18, wherein the step of receiving information about demands of the working fluid includes,

- receiving information about a predictable schedule.

Aspect 21. The method according to aspect 17-20, wherein the step of determining a target temperature of the working fluid includes

- receiving information about a fluid temperature at a fluid input;
- receiving information about a fluid temperature at a fluid output;
- receiving information about an indoor temperature; and/or
- receiving information about an outdoor temperature.

Aspect 22. The method according to aspect 17-21, wherein the step of determining an operation of the temperature regulating system includes

- receiving information of a working load of the temperature regulator; and/or
- regulating a cooling/heating capacity of the temperature regulators.

With regard to the foregoing disclosure, it is to be understood that variations may be made in detail, without departing from the scope of the present invention. It is intended that the specification and depicted embodiments are to be considered exemplary only, with a true scope and spirit of the invention being indicated by the broad meaning of the claims.

## Claims

What claimed is:

1. A temperature regulating system, comprising:
  - a fluid circuit including fluidly connected components, the fluid circuit includes a first and second temperature regulator, a first and second flow control device, a fluid input, and a fluid output, wherein,
    - the fluid input is disposed upstream of the first temperature regulator, and upstream of the second flow control device;
    - the fluid output is disposed downstream of the first flow control device, and downstream of the second temperature regulator;
    - the first temperature regulator is disposed downstream of the fluid input, upstream of the first flow control device, and upstream of the second flow control device;
    - the second temperature regulator is disposed downstream of the second flow control device, and upstream of the fluid output;
    - the first flow control device is disposed downstream of the first temperature regulator, and upstream of the fluid output; and
    - the second flow control device is disposed downstream of the fluid input, downstream of the first temperature regulator, and upstream of the second temperature regulator.
2. The temperature regulating system according to claim 1, the first flow control device includes a two-way valve.
3. The temperature regulating system according to claim 1, the second flow control device includes a three-way valve.
4. The temperature regulating system according to claim 1, the second flow control device further includes a check valve and a two-way valve, wherein,

the check valve is disposed downstream of the first temperature regulator and upstream of the second temperature regulator, the check valve regulates fluid to flow unidirectionally from the first temperature regulator to the second temperature regulator; and

the two-way valve is disposed downstream of the fluid input and upstream of the second temperature regulator,

5. The temperature regulating system according to claim 1, wherein the first or second temperature regulator includes at least one cooler or at least one heater.
6. The temperature regulating system according to claim 1, further includes a controller, the controller controls the temperature regulators and flow control devices.
7. The temperature regulating system according to claim 1, wherein the fluid circuit further comprises a third temperature regulator, and a third and fourth flow control device, wherein,  
the third temperature regulator is disposed downstream of the fourth flow control device, and upstream of the fluid output;  
the third flow control device is disposed downstream of the second temperature regulator, and upstream of the fluid output; and  
the fourth flow control device is disposed downstream of the fluid input, downstream of the second temperature regulator, and upstream of the third temperature regulator.
8. The temperature regulating system according to claim 7, the third flow control device includes a two-way valve.
9. The temperature regulating system according to claim 7, the fourth flow control device includes a three-way valve.
10. The temperature regulating system according to claim 7, the fourth flow control device further includes a check valve and a two-way valve, wherein,

the check valve is disposed downstream of the second temperature regulator and upstream of the third temperature regulator, the check valve regulates fluid to flow unidirectionally from the second temperature regulator to the third temperature regulator; and

the two-way valve is disposed downstream of the fluid input and upstream of the third temperature regulator.

11. The temperature regulating system according to claim 7, the third temperature regulator includes at least one cooler or at least one heater.

12. The temperature regulating system according to claim 7, wherein the fluid circuit further comprises a fourth temperature regulator, and a fifth and sixth flow control device, wherein,

the fourth temperature regulator is disposed downstream of the sixth flow control device, and upstream of the fluid output;

the fifth flow control device is disposed downstream of the third temperature regulator, and upstream of the fluid output; and

the sixth flow control device is disposed downstream of the fluid input, downstream of the third temperature regulator, and upstream of the fourth temperature regulator.

13. The temperature regulating system according to claim 12, the fifth flow control device includes a two-way valve.

14. The temperature regulating system according to claim 12, the sixth flow control device includes a three-way valve.

15. The temperature regulating system according to claim 12, the sixth flow control device further includes a check valve and a two-way valve, wherein,

the check valve is disposed downstream of the third temperature regulator and upstream of the fourth temperature regulator, the check valve regulates fluid to flow unidirectionally from the third temperature regulator to the fourth temperature regulator; and

the two-way valve is disposed downstream of the fluid input and upstream of the fourth temperature regulator.

16. A temperature regulating system, comprising:  
 a fluid circuit including fluidly connected components, the fluid circuit includes  
 a total number of  $i$  temperature regulators, where  
 $i = 1, 2, 3, 4 \dots N$ ;  $N$  can be any positive integer  $\geq 2$ ,  
 a total number of  $(2N - 2)$  flow control devices,  
 a fluid input, and  
 a fluid output,  
 wherein,  
 when  $i = 1$ ,  
 the  $i$ th temperature regulator is disposed downstream of the fluid input, upstream  
 of the  $(2i - 1)$ th flow control device, and upstream of the  $(2i)$ th flow control device;  
 the  $(2i - 1)$ th flow control device is disposed downstream to the  $i$ th temperature  
 regulator, and upstream of the fluid output,  
 the  $(2i)$ th flow control device, where is disposed downstream of the fluid input,  
 downstream of the  $i$ th temperature regulator, and upstream of the  $(i + 1)$ th temperature  
 regulator,  
 when  $1 < i < N$ ,  
 the  $i$ th temperature regulator is disposed downstream of the  $(2i - 2)$ th flow  
 control device, upstream of the  $(2i - 1)$ th flow control device, and upstream of the  $(2i)$ th flow  
 control device,  
 the  $(2i - 1)$ th flow control device is disposed downstream of the  $i$ th temperature  
 regulator, and upstream of the fluid output,  
 the  $(2i)$ th flow control device is disposed downstream to the fluid input,  
 downstream of the  $i$ th temperature regulator, and upstream of the  $(i + 1)$ th regulator;  
 when  $i = N$ ,  
 the  $i$ th temperature regulator is disposed downstream of the  $(2i - 2)$ th flow  
 control device, and upstream of the fluid output.
17. A method of controlling a temperature regulating system, comprising,  
 receiving information about an amount of a working fluid flowing into the system;

determining a target temperature of the working fluid; and  
determining an operation of the temperature regulating system to obtain the target temperature of the working fluid, further including  
when the fluid amount is less than a threshold amount, positioning a flow control device such that at least two temperature regulators in the temperature regulating system are in serial flow.

18. The method according of claim 17, wherein the step of receiving information about a fluid amount further comprises

receiving information about working fluid availability; and/or  
receiving information about demands of the working fluid

19. The method according to claim 18, wherein the step of receiving information about working fluid availability comprises

receiving information about the working fluid supply; and/or  
receiving information about a governmental regulation.

20. The method according to claim 18, wherein the step of receiving information about demands of the working fluid includes

receiving information about a predictable schedule.

21. The method according to claim 17, wherein the step of determining a target temperature comprises

receiving information about a fluid temperature at a fluid input;  
receiving information about a fluid temperature at a fluid output;  
receiving information about an indoor temperature; and/or  
receiving information about an outdoor temperature.

22. The method according to claim 17, where in the step of determining an operation of the temperature regulating system includes

receiving information of a working load of the temperature regulator; and/or

regulating a cooling/heating capacity of the temperature regulators.

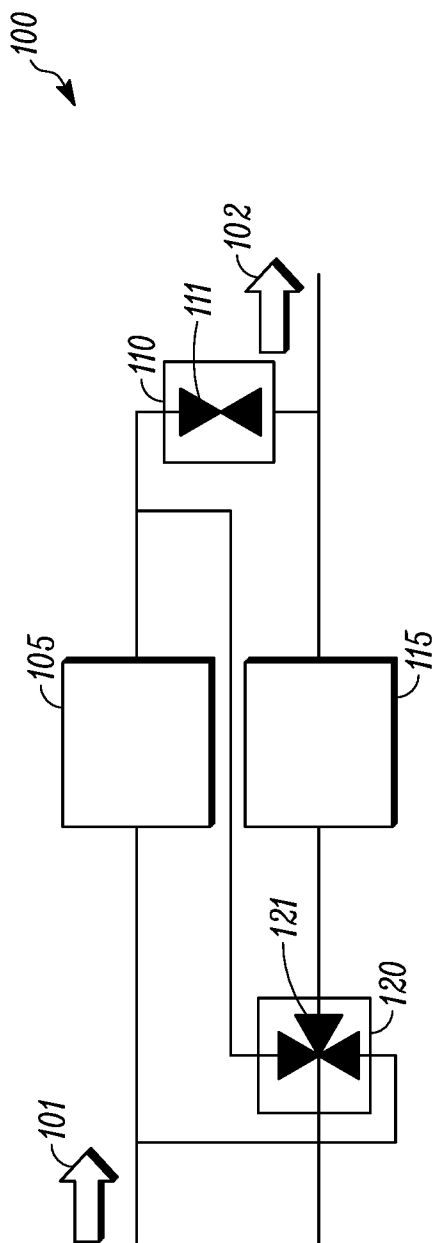

FIG. 1A

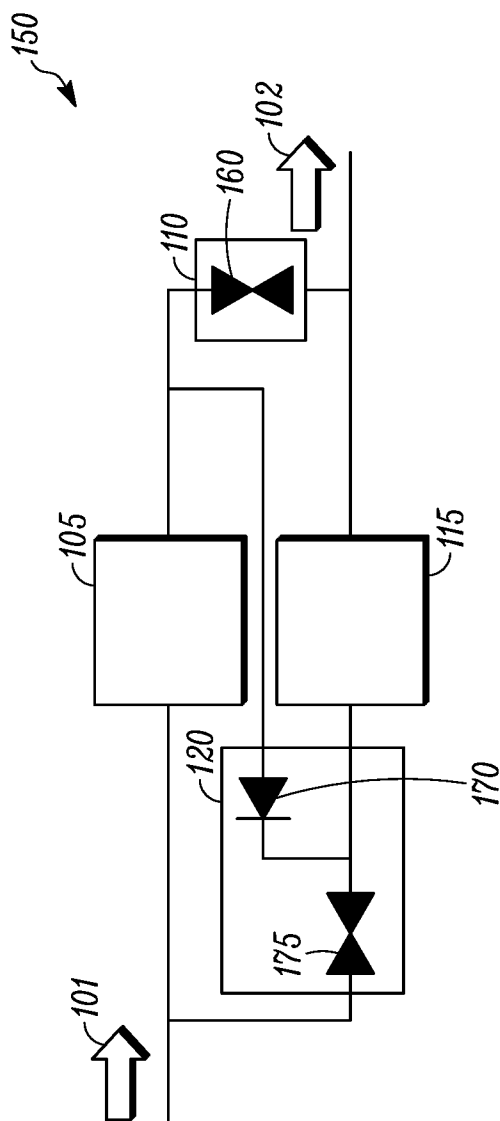

FIG. 1B

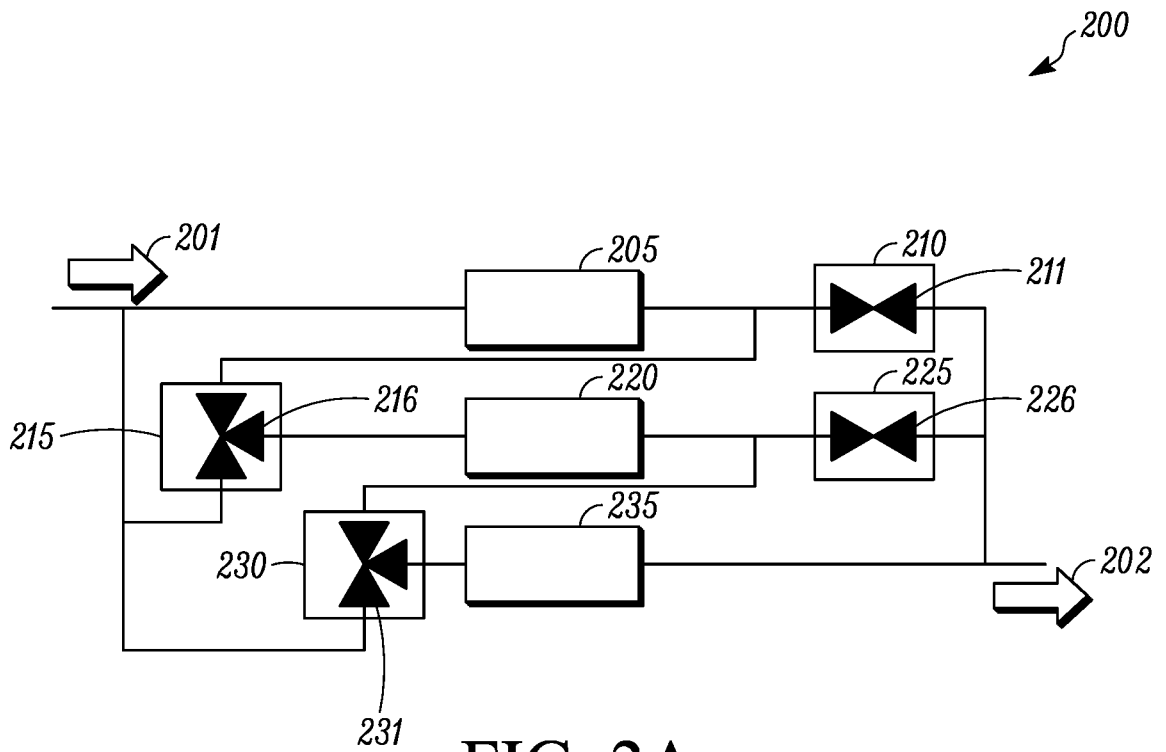

FIG. 2A

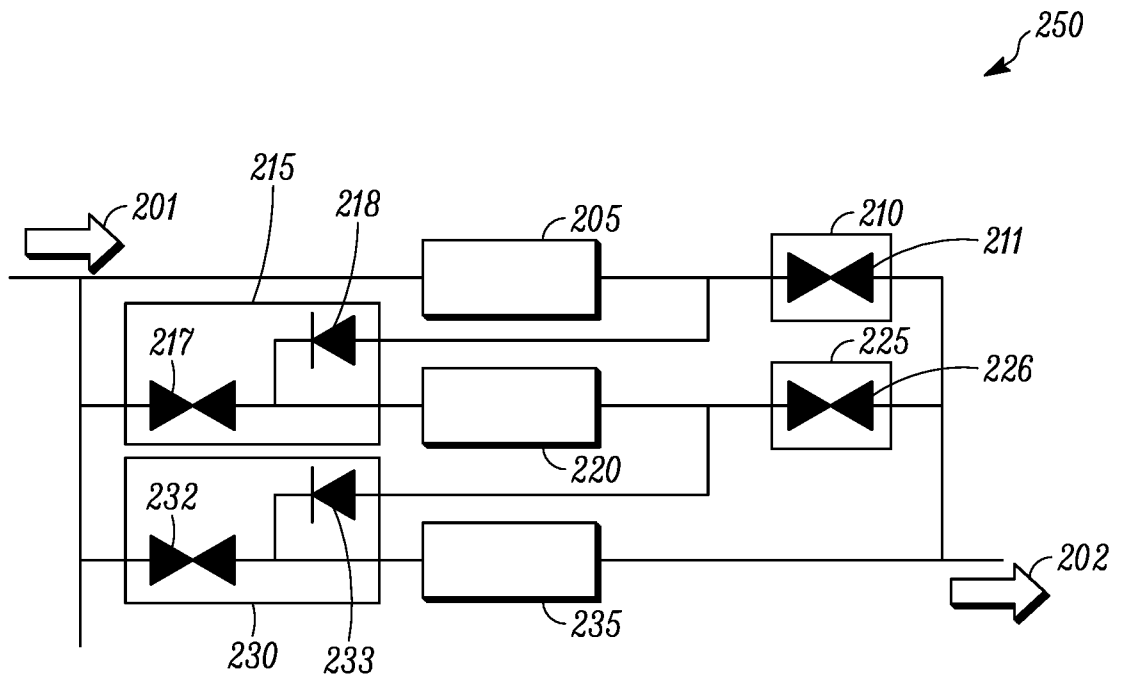

FIG. 2B

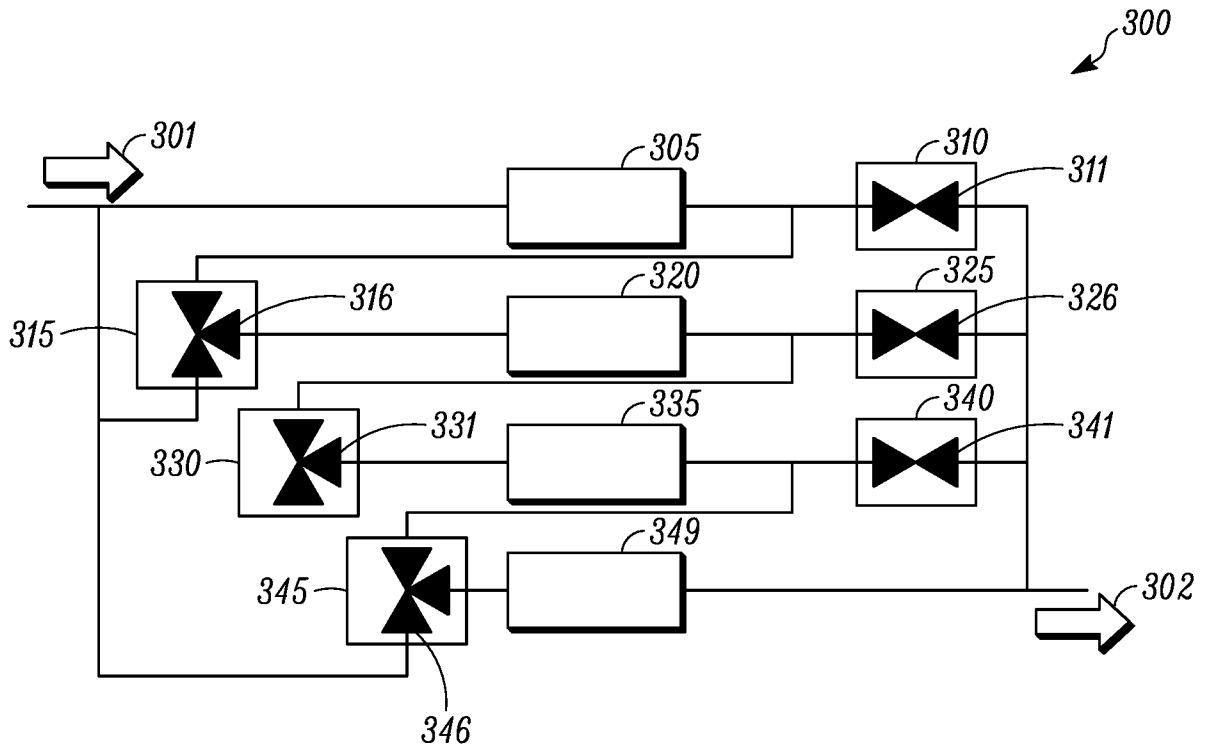

FIG. 3A

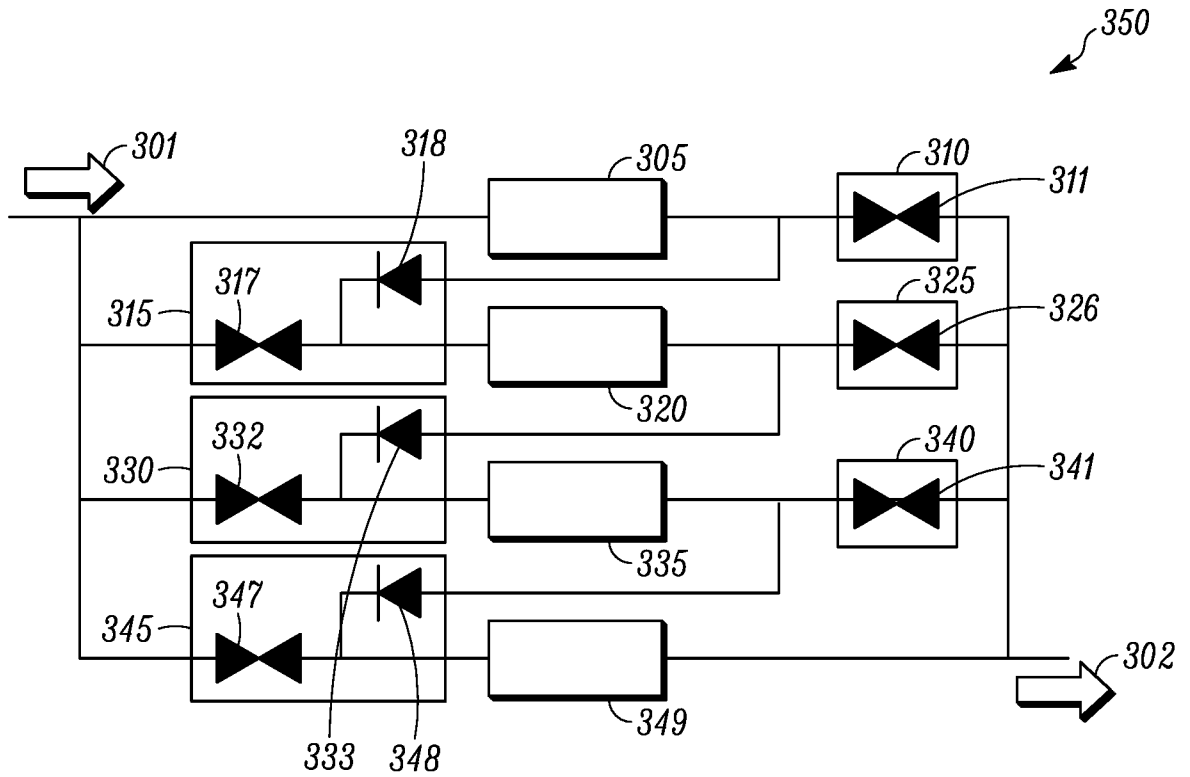

FIG. 3B

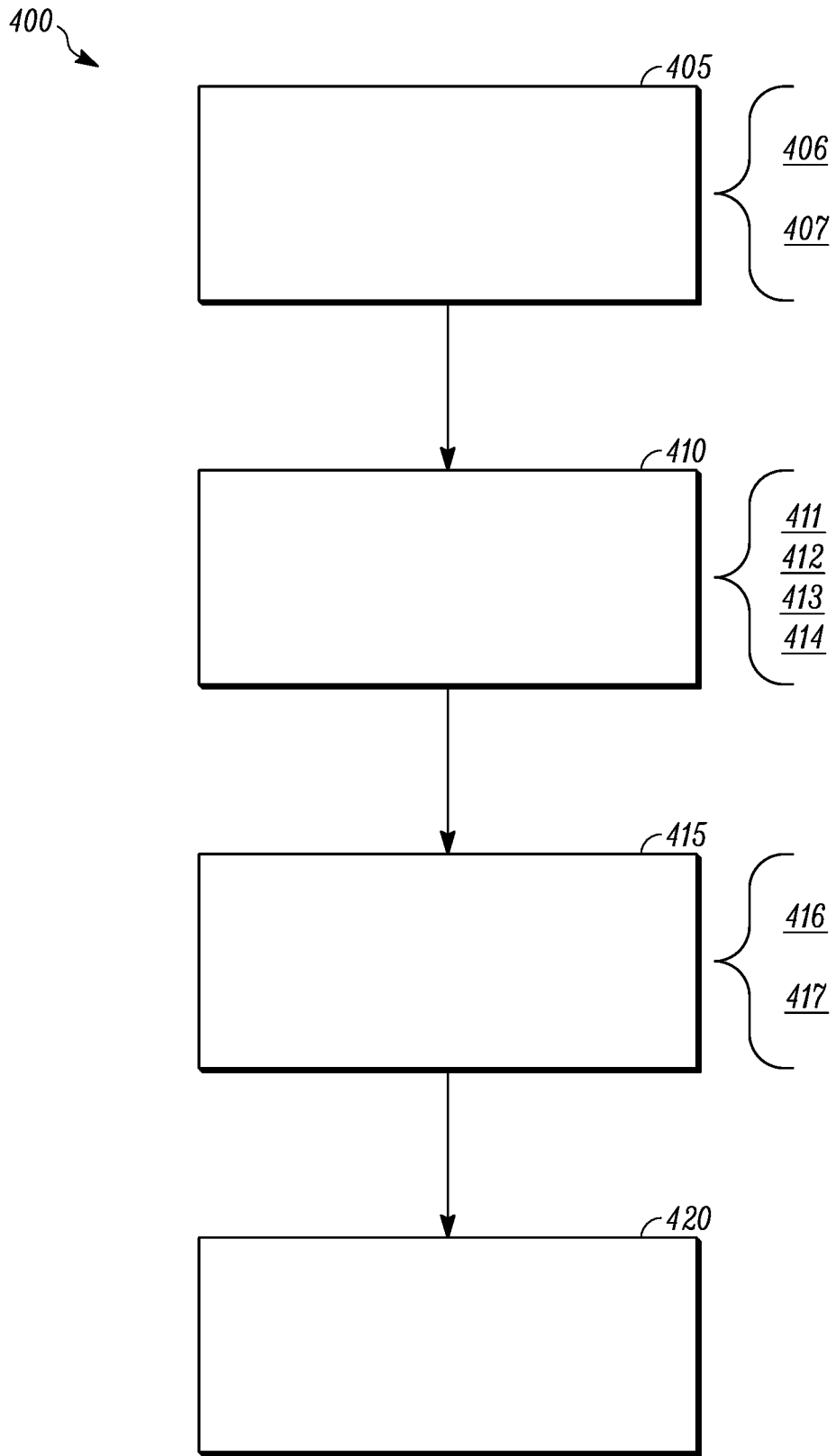

FIG. 4

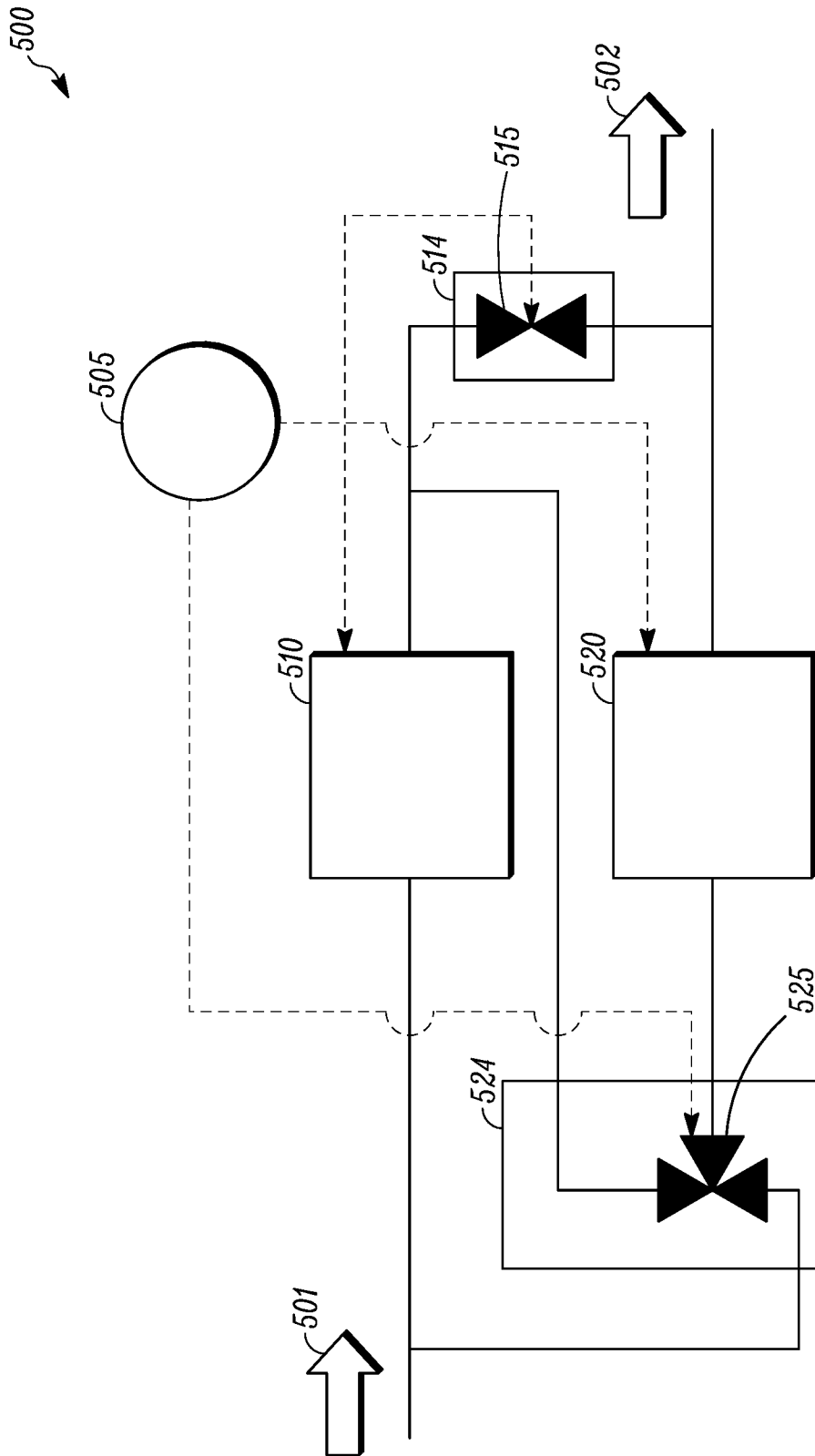

FIG. 5

## INTERNATIONAL SEARCH REPORT

International application No.

PCT/CN2014/094675

<b>A. CLASSIFICATION OF SUBJECT MATTER</b> F25B 5/00(2006.01)i  According to International Patent Classification (IPC) or to both national classification and IPC		
<b>B. FIELDS SEARCHED</b> Minimum documentation searched (classification system followed by classification symbols) F25B5/-  Documentation searched other than minimum documentation to the extent that such documents are included in the fields searched  Electronic data base consulted during the international search (name of data base and, where practicable, search terms used) WPI,EPODOC,CNPAT,CNKI: F25B5/-;temperature, regulating, regulated, regulator , upstream, downstream, flow, control, parallel, serial, capacity, cool, cooling, heat, heating, fluid		
<b>C. DOCUMENTS CONSIDERED TO BE RELEVANT</b>		
Category*	Citation of document, with indication, where appropriate, of the relevant passages	Relevant to claim No.
X	US 2007227146 A1 (SEIDEL, PESSACH) 04 October 2007 (2007-10-04) description paragraphs[0005], [0028], [0029], [0053], figure 6	1-16
X	CN 103884139 A (LIEBERT CORP.) 25 June 2014 (2014-06-25) description paragraphs[0023]-[0028]	17-22
A	WO 2014150886 A1 (JOHNSON CONTROLS TECHNOLOGY COMPANY) 25 September 2014 (2014-09-25) whole document	1-22
A	CN 2703988 Y (GUANGZHOU KELONG ELECTRIC APPLIANCE CO., LTD.) 08 June 2005 (2005-06-08) whole document	1-22
A	CN 102032630 A (SOUTHEAST UNIVERSITY ET AL.) 27 April 2011 (2011-04-27) whole document	1-22
A	CN 102116541 A (LIU, XIONG) 06 July 2011 (2011-07-06) whole document	1-22
<input checked="" type="checkbox"/> Further documents are listed in the continuation of Box C. <input checked="" type="checkbox"/> See patent family annex.		
* Special categories of cited documents: “A” document defining the general state of the art which is not considered to be of particular relevance “E” earlier application or patent but published on or after the international filing date “L” document which may throw doubts on priority claim(s) or which is cited to establish the publication date of another citation or other special reason (as specified) “O” document referring to an oral disclosure, use, exhibition or other means “P” document published prior to the international filing date but later than the priority date claimed “T” later document published after the international filing date or priority date and not in conflict with the application but cited to understand the principle or theory underlying the invention “X” document of particular relevance; the claimed invention cannot be considered novel or cannot be considered to involve an inventive step when the document is taken alone “Y” document of particular relevance; the claimed invention cannot be considered to involve an inventive step when the document is combined with one or more other such documents, such combination being obvious to a person skilled in the art “&” document member of the same patent family		
Date of the actual completion of the international search <b>15 August 2015</b>		Date of mailing of the international search report <b>28 August 2015</b>
Name and mailing address of the ISA/CN <b>STATE INTELLECTUAL PROPERTY OFFICE OF THE P.R.CHINA 6, Xitucheng Rd., Jimen Bridge, Haidian District, Beijing 100088, China</b> Facsimile No. (86-10)62019451		Authorized officer  <b>LIU,Mei</b>  Telephone No. (86-10)01061648431

INTERNATIONAL SEARCH REPORT

International application No.

**PCT/CN2014/094675**

**C. DOCUMENTS CONSIDERED TO BE RELEVANT**

Category*	Citation of document, with indication, where appropriate, of the relevant passages	Relevant to claim No.
A	CN 203404908 U (TCL AIR CONDITIONER ZHONGSHAN CO., LTD.) 22 January 2014 (2014-01-22) whole document	1-22
<hr/>		

**INTERNATIONAL SEARCH REPORT**  
**Information on patent family members**

International application No.

**PCT/CN2014/094675**

Patent document cited in search report			Publication date (day/month/year)	Patent family member(s)			Publication date (day/month/year)
US	2007227146	A1	04 October 2007	WO	2004097320	A8	10 March 2005
				US	7997079	B2	16 August 2011
				WO	2004097320	A2	11 November 2004
				EP	1625128	A2	15 February 2006
				IL	155665	A	04 May 2009
CN	103884139	A	25 June 2014	CN	103884125	A	25 June 2014
				EP	2755461	A2	16 July 2014
				WO	2012145263	A2	26 October 2012
				CN	103884050	A	25 June 2014
				US	2013098085	A1	25 April 2013
				EP	2700289	A2	26 February 2014
				US	9038404	B2	26 May 2015
				CN	103609206	A	26 February 2014
				US	2013098088	A1	25 April 2013
				US	2013098087	A1	25 April 2013
				US	8881541	B2	11 November 2014
				US	2013098086	A1	25 April 2013
				US	2014033753	A1	06 February 2014
				US	2015230367	A1	13 August 2015
WO	2014150886	A1	25 September 2014	US	2014260376	A1	18 September 2014
				TW	201447200	A	16 December 2014
CN	2703988	Y	08 June 2005	None			
CN	102032630	A	27 April 2011	CN	102032630	B	02 July 2014
CN	102116541	A	06 July 2011	CN	102116541	B	28 November 2012
CN	203404908	U	22 January 2014	None			