

N. A. PATTERSON.

Grain Separator.

No. 29,812.

Patented Aug. 28, 1860.

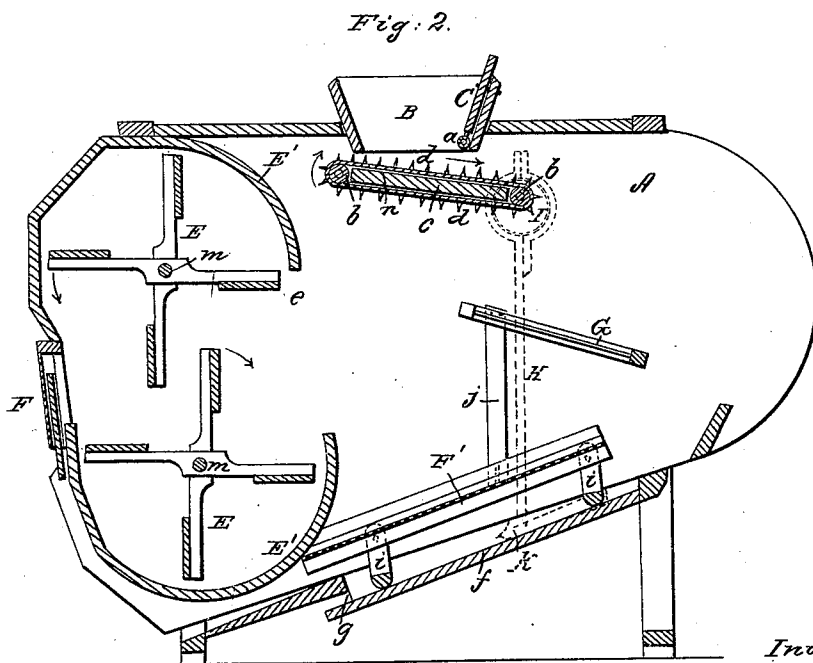
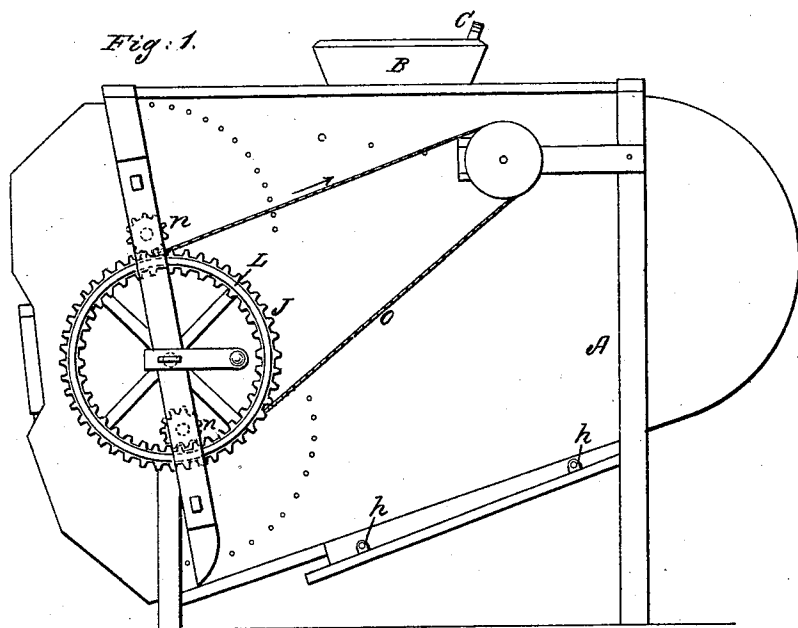

Witnesses:  
J. W. Coombs.  
R. S. Spencer.

Inventor:  
N. A. Patterson.  
per Mumford & Co.,  
Attorneys.

# UNITED STATES PATENT OFFICE.

N. A. PATTERSON, OF KINGSTON, TENNESSEE.

## GRAIN-SEPARATOR.

Specification of Letters Patent No. 29,812, dated August 28, 1860.

*To all whom it may concern:*

Be it known that I, N. A. PATTERSON, of Kingston, in the county of Roane and State of Tennessee, have invented a new and Improved Grain-Separator; and I do hereby declare that the following is a full, clear, and exact description of the same, reference being had to the annexed drawings, making a part of this specification, in which—

Figure 1 is a side view of my invention. Fig. 2 a side sectional view of the same the plane of section passing through the center.

Similar letters of reference indicate corresponding parts in the two figures.

To enable those skilled in the art to fully understand and construct my invention I will proceed to describe it.

A represents a case or box in the upper part of which a hopper B, is placed the front end of the hopper being provided with a slide C, having a roller *a*, at its lower end as shown in Fig. 2. Within the case or box A, and immediately below the hopper B, there is placed an endless apron D, slightly inclined, *b, b*, being the rollers over which the apron works and *c*, a supporting board between the rollers and the upper and lower sides of the apron. The apron D, is armed with teeth or spikes *d*, of a suitable length and it extends a little beyond the front part of the hopper.

Within the case or box at its back part there are placed two fans E, E, one above the other. These fans may be constructed in the usual or in any proper way and they are of such dimensions that the two may extend from the top to the bottom of the case and the paths of rotation of the two fans meet at the center and if desired overlap each other. In Fig. 2, the paths of rotation of the fans are shown overlapping each other. Each fan is fitted within a semi-cylindrical case E', the upper part of the upper fan and the lower part of the lower one being covered by the cases having an opening *e*, in front. The back part of the cases E', form the back of the case or box A, and a slide F, is inserted in the back of the case to supply the fans with air during their rotation.

The bottom *f*, of the case or box A, is inclined and is provided with an opening *g*, and directly over the bottom *f*, there are two parallel shafts *h, h*, the journals of which have their bearings in the sides of the box or case and are allowed to turn freely there-

in. To each shaft *h*, there are two vertical arms *i*, attached, one near each end, and the upper ends of these arms are pivoted to the sides of a screen F'. To each side of the screen F', a vertical bar *j*, is attached said bars supporting a screen G.

The screen G, is inclined, its front end being the lowest. The screen F', is inclined in a reverse direction.

One of the shafts *h*, extends through the side of the case A, and has an arm *k*, attached, the outer end of which is connected to the lower end of a vertical bar H, the upper part of which is provided with a yoke that is fitted on an eccentric I, at one end of the front roller *b*, of the apron D, see dotted lines in Fig. 1.

One end of each shaft *m* of the fans E, has a pinion *n*, on it and these pinions gear into a double toothed spur wheel J, which is placed on a driving shaft, said wheel having teeth on its outer and inner periphery and being at one side of the case or box. To the spur wheel J, a pulley L, is attached from which motion is communicated to the apron D, by a belt *o*.

The operation is as follows: The grain to be cleaned and separated from foreign substances is placed in the hopper B, and the driving shaft K, is rotated by any convenient power. The grain passes from the hopper on the endless apron D, the supply being regulated by adjusting the slide C, the roller *a*, admitting of the free passage of the grain underneath the slide whether the quantity allowed to escape be greater or less. The apron D, moves in the direction indicated by the arrows adjoining it and discharges the grain uniformly or regularly on the screen G, the latter as well as the screen F', vibrating longitudinally and with a rising and falling movement owing to their connection with the arms *i*, of the shafts *h*, the latter being actuated by the arm *k*, and vertical bar H, and eccentric I. The grain passes through screen H, the light coarse foreign substances being blown off from it by the blasts from the fans E, E, and the grain falls on screen F', which of course has the same movement as G, and efficiently separates the small grain, cockle and the like from the sound grain, the latter passing off the depressed end of the screen F', and the former passing through the latter and out from the case or box through the opening *g*. The two fans E, E, cause a

blast or volume of air to pass through the whole height of the case A, from the screen F', to the endless apron D, and effectually separates all light foreign substances from the grain, and the double toothed wheel J, and pinions *n*, *n*, constitute a very simple means for driving both fans from the same shaft.

I do not claim any of the within described parts when separately considered, and irrespective of the arrangement herein shown and described. But

I do claim as new and desire to secure by Letters Patent—

The arrangement as herein shown and described of the double toothed spur wheel J, pinions *n*, shafts *m*, and fans E, E, with the feeding apron D, bar H, eccentric I, and screens F', G, all as set forth for the purpose specified.

N. A. PATTERSON.

Witnesses:

M. L. PATTERSON,  
S. I. D'ARMOND.