



(51) International Patent Classification:
H04B 7/024 (2017.01)

(21) International Application Number:
PCT/CN2018/102996

(22) International Filing Date:
29 August 2018 (29.08.2018)

(25) Filing Language: English

(26) Publication Language: English

(71) Applicant: **QUALCOMM INCORPORATED** [US/US];
ATTN: International IP Administration, 5775 Morehouse
Drive, San Diego, CA 92121-1714 (US).

(72) Inventors; and

(71) Applicants (for US only): **HAO, Chenxi** [CN/CN]; 5775
Morehouse Drive, San Diego, CA 92121-1714 (US).
ZHANG, Yu [CN/CN]; 5775 Morehouse Drive, San Diego,

CA 92121-1714 (US). **WEI, Chao** [CN/CN]; 5775 More-
house Drive, San Diego, CA 92121-1714 (US). **WU,**
Liangming [CN/CN]; 5775 Morehouse Drive, San Diego,
CA 92121-1714 (US). **XU, Hao** [US/CN]; 5775 More-
house Drive, San Diego, CA 92121-1714 (US). **GAAL,**
Peter [US/US]; 5775 Morehouse Drive, San Diego, CA
92121-1714 (US). **CHEN, Wanshi** [CN/US]; 5775 More-
house Drive, San Diego, CA 92121-1714 (US).

(74) Agent: **NTD PATENT & TRADEMARK AGENCY
LTD.**; 10th Floor, Tower C, Beijing Global Trade Center,
36 North Third Ring Road East, Dongcheng District, Bei-
jing 100013 (CN).

(81) Designated States (unless otherwise indicated, for every
kind of national protection available): AE, AG, AL, AM,
AO, AT, AU, AZ, BA, BB, BG, BH, BN, BR, BW, BY, BZ,
CA, CH, CL, CN, CO, CR, CU, CZ, DE, DJ, DK, DM, DO,
DZ, EC, EE, EG, ES, FI, GB, GD, GE, GH, GM, GT, HN,

(54) Title: SINGLE AND MULTI-STAGE DOWNLINK CONTROL INFORMATION DESIGN FOR MULTIPLE TRANSCIEVER
NODES

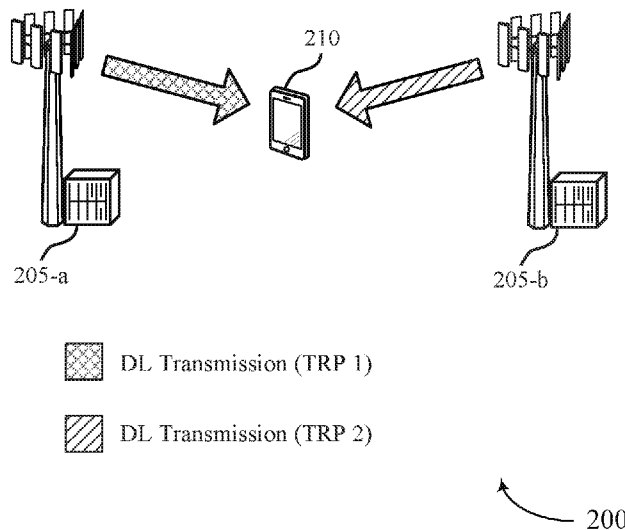

FIG. 2

(57) Abstract: Methods, systems, and devices for wireless communications are described. A user equipment (UE) may receive a downlink control information (DCI) message configuring a downlink transmission of one or more codewords (CWs) associated with one or more demodulation reference signal (DMRS) port groups, wherein the DCI message comprises a mode indicator, a common parameter set for the one or more DMRS port groups, and one or more DMRS port group-specific parameter set. The UE may determine, based at least in part on the mode indicator, a transmission scheme for the downlink transmission, wherein the transmission scheme comprises an association between the one or more DMRS port groups and the one or more CWs. The UE may determine, based at least in part on DCI message, at least one of a quasi-co-located (QCL) information, a rate matching configuration, and/or a resource allocation, for at least one DMRS port group.



HR, HU, ID, IL, IN, IR, IS, JO, JP, KE, KG, KH, KN, KP, KR, KW, KZ, LA, LC, LK, LR, LS, LU, LY, MA, MD, ME, MG, MK, MN, MW, MX, MY, MZ, NA, NG, NI, NO, NZ, OM, PA, PE, PG, PH, PL, PT, QA, RO, RS, RU, RW, SA, SC, SD, SE, SG, SK, SL, SM, ST, SV, SY, TH, TJ, TM, TN, TR, TT, TZ, UA, UG, US, UZ, VC, VN, ZA, ZM, ZW.

(84) Designated States (*unless otherwise indicated, for every kind of regional protection available*): ARIPO (BW, GH, GM, KE, LR, LS, MW, MZ, NA, RW, SD, SL, ST, SZ, TZ, UG, ZM, ZW), Eurasian (AM, AZ, BY, KG, KZ, RU, TJ, TM), European (AL, AT, BE, BG, CH, CY, CZ, DE, DK, EE, ES, FI, FR, GB, GR, HR, HU, IE, IS, IT, LT, LU, LV, MC, MK, MT, NL, NO, PL, PT, RO, RS, SE, SI, SK, SM, TR), OAPI (BF, BJ, CF, CG, CI, CM, GA, GN, GQ, GW, KM, ML, MR, NE, SN, TD, TG).

Declarations under Rule 4.17:

— *of inventorship (Rule 4.17(iv))*

Published:

— *with international search report (Art. 21(3))*

SINGLE AND MULTI-STAGE DOWNLINK CONTROL INFORMATION DESIGN FOR MULTIPLE TRANSCEIVER NODES

BACKGROUND

5 [0001] The following relates generally to wireless communications, and more specifically to single and multi-stage downlink control information (DCI) design for multiple transceiver nodes.

[0002] Wireless communications systems are widely deployed to provide various types of communication content such as voice, video, packet data, messaging, broadcast, and so on. These systems may be capable of supporting communication with multiple users by sharing 10 the available system resources (e.g., time, frequency, and power). Examples of such multiple-access systems include fourth generation (4G) systems such as Long Term Evolution (LTE) systems, LTE-Advanced (LTE-A) systems, or LTE-A Pro systems, and fifth generation (5G) systems which may be referred to as New Radio (NR) systems. These systems may employ technologies such as code division multiple access (CDMA), time division multiple access 15 (TDMA), frequency division multiple access (FDMA), orthogonal frequency division multiple access (OFDMA), or discrete Fourier transform-spread-OFDM (DFT-S-OFDM). A wireless multiple-access communications system may include a number of base stations or network access nodes, each simultaneously supporting communication for multiple communication devices, which may be otherwise known as user equipment (UE).

20 [0003] Wireless communication systems may use various transmission schemes to support communications between a UE and base station. In some examples, the transmission schemes may support transmissions from multiple transmission/reception points (TRPS), which may also be referred to as a transceiver nodes. That is, multiple transceiver nodes may be associated with a base station, or with multiple base stations, where each transceiver node 25 transmits the same or different information to the UE. In some aspects, a transmission scheme may refer to an association between one or more reference signal port groups and one or more codewords. Examples of transmission schemes include, but are not limited to, each transceiver node transmitting a unique codeword to the UE during the downlink transmission, each transceiver node transmitting a different part of the same codeword to the UE, and/or 30 each transceiver node transmitting a different version of the same codeword to the UE. Typically, conventional techniques require a separate downlink grant, e.g., a DCI, indicating

resources for the downlink transmission from the respective transceiver node. However, this approach is inefficient and involves increased overhead in terms of signaling, resources, and the like.

SUMMARY

5 [0004] The described techniques relate to improved methods, systems, devices, and apparatuses that support single and multi-stage downlink control information (DCI) design for multiple transceiver nodes. Generally, the described techniques provide for various techniques for signaling or otherwise providing an indication of a transmission scheme to a user equipment (UE) using a more efficient DCI design. For example, the UE may receive a DCI message that configures a downlink transmission for the UE. Broadly, the downlink
10 transmission may include one or more codewords that are associated with one or more demodulation reference signals (DMRS) port groups. In some aspects, the DCI message may carry or otherwise provide an indication of a mode indicator that the UE can use to determine the transmission scheme for the downlink transmission. In some examples, the DCI message may also carry or otherwise provide an indication of a common parameter set for the DMRS
15 port groups as well as one or more DMRS port groups specific parameter sets. In some examples, the UE may use these parameter sets to determine or otherwise identify quasi-co-located (QCL) information, a rate matching configuration, and/or a resource allocation for a DMRS port group. Generally, the UE may use this information to receive the downlink
20 transmission from the transceiver nodes. In some aspects, a multi-stage DCI message may be used. For example, the first DCI message may indicate a DMRS port groups specific parameter set for a first transceiver node and may also identify or more scheduling resources for receiving a second DCI message that carries or otherwise provides an indication of a DMRS port group specific parameter set for a second transceiver node.

25 [0005] A method of wireless communication at a UE is described. The method may include receiving a DCI message configuring a downlink transmission of one or more CWs associated with one or more DMRS port groups, where the DCI message includes a mode indicator, a common parameter set for the one or more DMRS port groups, and one or more DMRS port group-specific parameter set, determining, based on the mode indicator, a
30 transmission scheme for the downlink transmission, where the transmission scheme includes an association between the one or more DMRS port groups and the one or more CWs, and

determining, based on at least one of the common parameter set for the one or more DMRS port groups, the one or more DMRS port group-specific parameter set, or a combination thereof, at least one of QCL information, a rate matching configuration, a resource allocation, or a combination thereof, for at least one DMRS port group.

5 **[0006]** An apparatus for wireless communication at a UE is described. The apparatus may include a processor, memory in electronic communication with the processor, and instructions stored in the memory. The instructions may be executable by the processor to cause the apparatus to receive a DCI message configuring a downlink transmission of one or more CWs associated with one or more DMRS port groups, where the DCI message includes
10 a mode indicator, a common parameter set for the one or more DMRS port groups, and one or more DMRS port group-specific parameter set, determine, based on the mode indicator, a transmission scheme for the downlink transmission, where the transmission scheme includes an association between the one or more DMRS port groups and the one or more CWs, and determine, based on at least one of the common parameter set for the one or more DMRS port
15 groups, the one or more DMRS port group-specific parameter set, or a combination thereof, at least one of QCL information, a rate matching configuration, a resource allocation, or a combination thereof, for at least one DMRS port group.

[0007] Another apparatus for wireless communication at a UE is described. The apparatus may include means for receiving a DCI message configuring a downlink
20 transmission of one or more CWs associated with one or more DMRS port groups, where the DCI message includes a mode indicator, a common parameter set for the one or more DMRS port groups, and one or more DMRS port group-specific parameter set, determining, based on the mode indicator, a transmission scheme for the downlink transmission, where the transmission scheme includes an association between the one or more DMRS port groups and
25 the one or more CWs, and determining, based on at least one of the common parameter set for the one or more DMRS port groups, the one or more DMRS port group-specific parameter set, or a combination thereof, at least one of QCL information, a rate matching configuration, a resource allocation, or a combination thereof, for at least one DMRS port group.

30 **[0008]** A non-transitory computer-readable medium storing code for wireless communication at a UE is described. The code may include instructions executable by a

processor to receive a DCI message configuring a downlink transmission of one or more CWs associated with one or more DMRS port groups, where the DCI message includes a mode indicator, a common parameter set for the one or more DMRS port groups, and one or more DMRS port group-specific parameter set, determine, based on the mode indicator, a transmission scheme for the downlink transmission, where the transmission scheme includes an association between the one or more DMRS port groups and the one or more CWs, and determine, based on at least one of the common parameter set for the one or more DMRS port groups, the one or more DMRS port group-specific parameter set, or a combination thereof, at least one of QCL information, a rate matching configuration, a resource allocation, or a combination thereof, for at least one DMRS port group.

[0009] Some examples of the method, apparatuses, and non-transitory computer-readable medium described herein may further include operations, features, means, or instructions for determining, based on a first DMRS port group-specific parameter set, at least one of a first QCL information, a first rate matching configuration, a first resource allocation, or a combination thereof, for a first DMRS port group and determining, based on a second DMRS port group-specific parameter set, at least one of a second QCL information, a second rate matching configuration, a second resource allocation, or a combination thereof, for a second DMRS port group.

[0010] In some examples of the method, apparatuses, and non-transitory computer-readable medium described herein, each of the one or more DMRS port group-specific parameter set includes an indication of at least one of a frequency domain resource allocation, a time domain resource allocation, the QCL information, the rate matching configuration, or combinations thereof, for an associated DMRS port group.

[0011] Some examples of the method, apparatuses, and non-transitory computer-readable medium described herein may further include operations, features, means, or instructions for identifying one or more DCI message formats based on the one or more DMRS port group-specific parameter sets and determining the DCI message format for the DCI message based on at least one of a CRC scrambling sequence associated with each of the one or more DCI message formats, a payload size of each of the one or more DCI message formats, or a combination thereof.

[0012] In some examples of the method, apparatuses, and non-transitory computer-readable medium described herein, the common parameter set includes an indication of at least one of a CW configuration for each CW being communicated during the downlink transmission, a HARQ process number, a HARQ timing parameter, a downlink assignment index, a frequency resource allocation common to each DMRS port group, a time resource allocation common to each DMRS port group, a DMRS port grouping, or a combination thereof.

[0013] Some examples of the method, apparatuses, and non-transitory computer-readable medium described herein may further include operations, features, means, or instructions for identifying a scrambling sequence used to scramble the DCI message, where the scrambling sequence includes the mode indicator.

[0014] In some examples of the method, apparatuses, and non-transitory computer-readable medium described herein, the DCI message includes one or more bits or fields configured to indicate the mode indicator.

[0015] Some examples of the method, apparatuses, and non-transitory computer-readable medium described herein may further include operations, features, means, or instructions for receiving a signal indicating a set of supported transmission schemes and identifying the transmission scheme from the set of supported transmission schemes based on the mode indicator.

[0016] In some examples of the method, apparatuses, and non-transitory computer-readable medium described herein, the transmission scheme includes a first TB associated with a first CW being communicated using a first DMRS port group and a second TB associated with a second CW being communicated using a second DMRS port group.

[0017] In some examples of the method, apparatuses, and non-transitory computer-readable medium described herein, a first data stream associated with the first TB that may be associated with the first CW may be mapped to the first DMRS port group according to an order including a first layer of the first DMRS port group, then a frequency resource allocation of the first DMRS port group, and then a time resource allocation of the first DMRS port group and a second data stream associated with the second TB that may be associated with the second CW may be mapped to the second DMRS port group according to an order including a second layer of the second DMRS port group, then a frequency resource

allocation of the second DMRS port group, and then a time resource allocation of the second DMRS port group.

[0018] In some examples of the method, apparatuses, and non-transitory computer-readable medium described herein, the transmission scheme includes a TB associated with a first CW being communicated using a first DMRS port group and a second DMRS port group, where a first version of the CW may be communicated from the first DMRS port group and a second version of the CW may be communicated from the second DMRS port group.

[0019] In some examples of the method, apparatuses, and non-transitory computer-readable medium described herein, the first and second versions of the CW include a different redundancy version or a different mapping function between the TB and the DMRS port group.

[0020] In some examples of the method, apparatuses, and non-transitory computer-readable medium described herein, a first data stream associated with a first version of the TB that may be associated with the CW may be mapped to the first DMRS port group according to an order including a first layer of the first DMRS port group, then a frequency resource allocation of the first DMRS port group, and then a time resource allocation of the first DMRS port group and a second data stream associated with a second version of the TB that may be associated with the CW may be mapped to the second DMRS port group according to an order including a second layer of the second DMRS port group, then a frequency resource allocation of the second DMRS port group, and then a time resource allocation of the second DMRS port group.

[0021] In some examples of the method, apparatuses, and non-transitory computer-readable medium described herein, the transmission scheme includes a TB associated with a first CW being communicated using a first DMRS port group and a second DMRS port group, where a first portion of the CW may be communicated from the first DMRS port group and a second portion of the CW may be communicated from the second DMRS port group.

[0022] In some examples of the method, apparatuses, and non-transitory computer-readable medium described herein, a first data stream associated with a first portion of the TB that may be associated with the CW may be mapped to the first DMRS port group according

to an order including a first layer of the first DMRS port group, then a frequency resource allocation of the first DMRS port group, and then a time resource allocation of the first DMRS port group and a second data stream associated with a second portion of the TB that may be associated with the CW may be mapped to the second DMRS port group according to an order including a second layer of the second DMRS port group, then a frequency resource allocation of the second DMRS port group, and then a time resource allocation of the second DMRS port group.

[0023] Some examples of the method, apparatuses, and non-transitory computer-readable medium described herein may further include operations, features, means, or instructions for aggregating, based on an index associated with each DMRS port of the first DMRS port group and the second DMRS port group, the DMRS port of the first DMRS port group and the second DMRS port group to form an aggregated DMRS port, aggregating, based on an index associated with each resource element associated with a frequency resource allocation and a time resource allocation associated with the first DMRS port group and second DMRS port group, a frequency resource allocation and a time resource allocation associated with the first DMRS port group and the second DMRS port group to form an aggregated frequency resource allocation and an aggregated time resource allocation and mapping a data stream of the TB associated with the CW according to the order including one or more layers associated with the aggregated DMRS port, then the aggregated frequency resource allocation, and then the aggregated time resource allocation.

[0024] Some examples of the method, apparatuses, and non-transitory computer-readable medium described herein may further include operations, features, means, or instructions for determining that a first DMRS port group and a second DMRS port group may be configured with a same frequency resource allocation and time resource allocation and determining that the first DMRS port group and the second DMRS port group may be configured with different DMRS ports.

[0025] Some examples of the method, apparatuses, and non-transitory computer-readable medium described herein may further include operations, features, means, or instructions for determining that a first DMRS port group and a second DMRS port group may be configured with a different frequency resource allocation and time resource allocation, determining that the first DMRS port group may be active in the frequency resource allocation and time

resource allocation associated with the first DMRS port group and determining that the second DMRS port group may be active in the frequency resource allocation and time resource allocation associated with the second DMRS port group.

5 [0026] Some examples of the method, apparatuses, and non-transitory computer-readable medium described herein may further include operations, features, means, or instructions for determining that a first DMRS port group and a second DMRS port group share one or more DMRS ports, but may be configured with a different frequency resource allocation and time resource allocation, determining that at least one of a first QCL information, a first rate matching configuration, or a combination thereof, may be applied to the shared one or more
10 DMRS ports using a frequency resource allocation and time resource allocation associated with the first DMRS port group and determining that at least one of a second QCL information, a second rate matching configuration, or a combination thereof, may be applied to the shared one or more DMRS ports using a frequency resource allocation and time resource allocation associated with the second DMRS port group.

15 [0027] In some examples of the method, apparatuses, and non-transitory computer-readable medium described herein, the DCI message may include operations, features, means, or instructions for receiving the second DCI message that includes an indication of a second DMRS port group-specific parameter set.

20 [0028] In some examples of the method, apparatuses, and non-transitory computer-readable medium described herein, the indication of the resource includes an indication of a starting resource block for receiving the second DCI message.

[0029] Some examples of the method, apparatuses, and non-transitory computer-readable medium described herein may further include operations, features, means, or instructions for determining, based on the starting resource block for the second DCI message, a payload size
25 for the second DCI message, determining, based on the payload size, whether the resource allocation for the first DMRS port group may be the same as or different from the resource allocation for the second DMRS port group, determining, upon a determination that the resource allocation for the first DMRS port group may be the same as the resource allocation for the second DMRS port group, that the second DMRS port group-specific parameter set
30 does not indicate the resource allocation for the second DMRS port group and determining, upon a determination that the resource allocation for the first DMRS port group may be

different from the resource allocation for the second DMRS port group, that the second DMRS port group-specific parameter set does indicate the resource allocation for the second DMRS port group.

[0030] In some examples of the method, apparatuses, and non-transitory computer-readable medium described herein, the indication of the resource includes an indication of a component carrier identifier or a cell identifier, where the component carrier identifier or the cell identifier conveys an indication of a starting resource block for receiving the second DCI message.

[0031] Some examples of the method, apparatuses, and non-transitory computer-readable medium described herein may further include operations, features, means, or instructions for determining, based on the starting resource block for the second DCI message, a payload size for the second DCI message, determining, based on the payload size, whether the resource allocation for the first DMRS port group may be the same as or different from the resource allocation for the second DMRS port group, determining, upon a determination that the resource allocation for the first DMRS port group may be the same as the resource allocation for the second DMRS port group, that the second DMRS port group-specific parameter set does not indicate the resource allocation for the second DMRS port group and determining, upon a determination that the resource allocation for the first DMRS port group may be different from the resource allocation for the second DMRS port group, that the second DMRS port group-specific parameter set does indicate the resource allocation for the second DMRS port group.

[0032] In some examples of the method, apparatuses, and non-transitory computer-readable medium described herein, the indication of the resource may include operations, features, means, or instructions for determining, based on an indicator, a payload size of the second DCI message conveying the second DMRS port group-specific parameter set for the second DMRS port group, determining, based on the payload size, the resource allocation for the second DCI message, determining, upon a determination that the resource allocation for the first DMRS port group may be the same as the resource allocation for the second DMRS port group, that the second DMRS port group-specific parameter set does not indicate the resource allocation for the second DMRS port group and determining, upon a determination that the resource allocation for the first DMRS port group may be different from the resource

allocation for the second DMRS port group, that the second DMRS port group-specific parameter set does indicate the resource allocation for the second DMRS port group.

5 **[0033]** Some examples of the method, apparatuses, and non-transitory computer-readable medium described herein may further include operations, features, means, or instructions for determining, based on the mode indicator, a payload size of the second DCI message conveying the second DMRS port group-specific parameter set for the second DMRS port group, determining, based on the payload size, the resource allocation for the second DCI message, determining, upon a determination that the resource allocation for the first DMRS port group may be the same as the resource allocation for the second DMRS port group, that 10 the second DMRS port group-specific parameter set does not indicate the resource allocation for the second DMRS port group and determining, upon a determination that the resource allocation for the first DMRS port group may be different from the resource allocation for the second DMRS port group, that the second DMRS port group-specific parameter set does indicate the resource allocation for the second DMRS port group.

15 **[0034]** Some examples of the method, apparatuses, and non-transitory computer-readable medium described herein may further include operations, features, means, or instructions for determining, based on one or more bits or fields in the DCI message that explicitly indicates the resource for the second DCI message, a resource occupancy for the second DCI message, determining, based on the resource occupancy, whether the resource allocation for the first 20 DMRS port group may be the same as or different from the resource allocation for the second DMRS port group, determining, upon a determination that the resource allocation for the first DMRS port group may be the same as the resource allocation for the second DMRS port group, that the second DMRS port group-specific parameter set does not indicate the resource allocation for the second DMRS port group and determining, upon a determination that the 25 resource allocation for the first DMRS port group may be different from the resource allocation for the second DMRS port group, that the second DMRS port group-specific parameter set does indicate the resource allocation for the second DMRS port group.

[0035] Some examples of the method, apparatuses, and non-transitory computer-readable medium described herein may further include operations, features, means, or instructions for 30 determining that the second DCI message could not be decoded, determining, based on the transmission scheme, that the first DMRS port group and at least one port of the second

DMRS port group may be associated with different portions of a TB of a CW and transmitting a signal indicating that at least the second DCI message or the TB could not be decoded.

5 [0036] Some examples of the method, apparatuses, and non-transitory computer-readable medium described herein may further include operations, features, means, or instructions for determining that the second DCI message could not be decoded, determining, based on the transmission scheme, that the first DMRS port group and at least one DMRS port of the second DMRS port group may be associated with different TBs and transmitting a first signal indicating a decoding result of the TB associated with the first DMRS port group.

10 [0037] Some examples of the method, apparatuses, and non-transitory computer-readable medium described herein may further include operations, features, means, or instructions for transmitting a second signal indicating that at least the second DCI message or the TB associated with the second DMRS port group could not be decoded.

15 [0038] Some examples of the method, apparatuses, and non-transitory computer-readable medium described herein may further include operations, features, means, or instructions for determining that the second DCI message could not be decoded, determining, based on the transmission scheme, that the first DMRS port group and at least one DMRS port of the second DMRS port group may be associated with different versions of a TB associated with a CW and transmitting a first signal indicating a decoding result of the TB.

20 [0039] Some examples of the method, apparatuses, and non-transitory computer-readable medium described herein may further include operations, features, means, or instructions for transmitting a second signal indicating that the second DCI message could not be decoded.

25 [0040] A method of wireless communication at a base station is described. The method may include determining that a downlink transmission to a UE is to occur, the downlink transmission including one or more CWs associated with one or more DMRS port groups, configuring a DCI message to indicate a mode indicator, a common parameter set for the one or more DMRS port groups, and one or more DMRS port group-specific parameter set, where the mode indicator provides an indication of the association between the one or more DMRS port groups and the one or more CWs being communicated during the downlink transmission,
30 and transmitting the DCI message to configure the downlink transmission.

[0041] An apparatus for wireless communication at a base station is described. The apparatus may include a processor, memory in electronic communication with the processor, and instructions stored in the memory. The instructions may be executable by the processor to cause the apparatus to determine that a downlink transmission to a UE is to occur, the
5 downlink transmission including one or more CWs associated with one or more DMRS port groups, configure a DCI message to indicate a mode indicator, a common parameter set for the one or more DMRS port groups, and one or more DMRS port group-specific parameter set, where the mode indicator provides an indication of the association between the one or more DMRS port groups and the one or more CWs being communicated during the downlink
10 transmission, and transmit the DCI message to configure the downlink transmission.

[0042] Another apparatus for wireless communication at a base station is described. The apparatus may include means for determining that a downlink transmission to a UE is to occur, the downlink transmission including one or more CWs associated with one or more DMRS port groups, configuring a DCI message to indicate a mode indicator, a common
15 parameter set for the one or more DMRS port groups, and one or more DMRS port group-specific parameter set, where the mode indicator provides an indication of the association between the one or more DMRS port groups and the one or more CWs being communicated during the downlink transmission, and transmitting the DCI message to configure the downlink transmission.

[0043] A non-transitory computer-readable medium storing code for wireless
20 communication at a base station is described. The code may include instructions executable by a processor to determine that a downlink transmission to a UE is to occur, the downlink transmission including one or more CWs associated with one or more DMRS port groups, configure a DCI message to indicate a mode indicator, a common parameter set for the one or
25 more DMRS port groups, and one or more DMRS port group-specific parameter set, where the mode indicator provides an indication of the association between the one or more DMRS port groups and the one or more CWs being communicated during the downlink transmission, and transmit the DCI message to configure the downlink transmission.

[0044] Some examples of the method, apparatuses, and non-transitory computer-readable
30 medium described herein may further include operations, features, means, or instructions for configuring a first DMRS port group-specific parameter set to indicate at least one of a first

QCL information, a first rate matching configuration, a first resource allocation, or a combination thereof, for a first DMRS port group and configuring a second DMRS port group-specific parameter set to indicate at least one of a second QCL information, a second rate matching configuration, a second resource allocation, or a combination thereof, for a
5 second DMRS port group.

[0045] In some examples of the method, apparatuses, and non-transitory computer-readable medium described herein, each of the one or more DMRS port group-specific parameter set includes an indication of at least one of a frequency domain resource allocation, a time domain resource allocation, the QCL information, the rate matching configuration, or
10 combinations thereof, for an associated DMRS port group.

[0046] Some examples of the method, apparatuses, and non-transitory computer-readable medium described herein may further include operations, features, means, or instructions for identifying one or more DCI message formats based on the one or more DMRS port group-specific parameter sets, selecting the DCI message format for the DCI message based on at
15 least one of the one or more DMRS port group-specific parameter sets or the common parameter set for the one or more DMRS port groups and scrambling the DCI message using a CRC scrambling sequence associated with the selected DCI message format.

[0047] In some examples of the method, apparatuses, and non-transitory computer-readable medium described herein, the common parameter set includes an indication of at
20 least one of a CW configuration for each CW being communicated during the downlink transmission, a HARQ process number, a HARQ timing parameter, a downlink assignment index, a frequency resource allocation common to each DMRS port group, a time resource allocation common to each DMRS port group, a DMRS port grouping, or a combination thereof.

[0048] Some examples of the method, apparatuses, and non-transitory computer-readable medium described herein may further include operations, features, means, or instructions for identifying a scrambling sequence used to scramble the DCI message, where the scrambling sequence indicates the mode indicator.
25

[0049] In some examples of the method, apparatuses, and non-transitory computer-readable medium described herein, the DCI message includes one or more bits or fields
30 configured to indicate the mode indicator.

- 5 [0050] Some examples of the method, apparatuses, and non-transitory computer-readable medium described herein may further include operations, features, means, or instructions for transmitting a signal indicating a set of supported transmission schemes, determining a transmission scheme from the set of supported transmission schemes and transmitting the DCI message conveying the mode indicator to indicate the determined transmission scheme.
- [0051] In some examples of the method, apparatuses, and non-transitory computer-readable medium described herein, the transmission scheme includes a first TB associated with a first CW being communicated using a first DMRS port group and a second TB associated with a second CW being communicated using a second DMRS port group.
- 10 [0052] In some examples of the method, apparatuses, and non-transitory computer-readable medium described herein, a first data stream associated with the first TB that may be associated with the first CW may be mapped to the first DMRS port group according to an order including a first layer of the first DMRS port group, then a frequency resource allocation of the first DMRS port group, and then a time resource allocation of the first
- 15 DMRS port group and a second data stream associated with the second TB that may be associated with the second CW may be mapped to the second DMRS port group according to an order including a second layer of the second DMRS port group, then a frequency resource allocation of the second DMRS port group, and then a time resource allocation of the second DMRS port group.
- 20 [0053] In some examples of the method, apparatuses, and non-transitory computer-readable medium described herein, the transmission scheme includes a TB associated with a first CW being communicated using a first DMRS port group and a second DMRS port group, where a first version of the CW may be communicated from the first DMRS port group and a second version of the CW may be communicated from the second DMRS port
- 25 group.
- [0054] In some examples of the method, apparatuses, and non-transitory computer-readable medium described herein, the first and second versions of the CW include a different redundancy version or a different mapping function between the TB and the DMRS port group.
- 30 [0055] In some examples of the method, apparatuses, and non-transitory computer-readable medium described herein, a first data stream associated with a first version of the TB

that may be associated with the CW may be mapped to the first DMRS port group according to an order including a first layer of the first DMRS port group, then a frequency resource allocation of the first DMRS port group, and then a time resource allocation of the first DMRS port group and a second data stream associated with a second version of the TB that
5 may be associated with the CW may be mapped to the second DMRS port group according to an order including a second layer of the second DMRS port group, then a frequency resource allocation of the second DMRS port group, and then a time resource allocation of the second DMRS port group.

[0056] In some examples of the method, apparatuses, and non-transitory computer-readable medium described herein, the transmission scheme includes a TB associated with a
10 first CW being communicated using a first DMRS port group and a second DMRS port group, where a first portion of the CW may be communicated from the first DMRS port group and a second portion of the CW may be communicated from the second DMRS port group.

[0057] In some examples of the method, apparatuses, and non-transitory computer-readable medium described herein, a first data stream associated with a first portion of the TB that may be associated with the CW may be mapped to the first DMRS port group according to an order including a first layer of the first DMRS port group, then a frequency resource allocation of the first DMRS port group, and then a time resource allocation of the first
20 DMRS port group and a second data stream associated with a second portion of the TB that may be associated with the CW may be mapped to the second DMRS port group according to an order including a second layer of the second DMRS port group, then a frequency resource allocation of the second DMRS port group, and then a time resource allocation of the second DMRS port group.

[0058] Some examples of the method, apparatuses, and non-transitory computer-readable medium described herein may further include operations, features, means, or instructions for aggregating, based on an index associated with each DMRS port of the first DMRS port group and the second DMRS port group, the DMRS port of the first DMRS port group and the second DMRS port group to form an aggregated DMRS port, aggregating, based on an
30 index associated with each resource element associated with a frequency resource allocation and a time resource allocation, the frequency resource allocation and the time resource

allocation to form an aggregated frequency resource allocation and an aggregated time resource allocation and mapping a data stream of the TB associated with the CW according to the order including one or more layers associated with the aggregated DMRS port, then the aggregated frequency resource allocation, and then the aggregated time resource allocation.

5 [0059] Some examples of the method, apparatuses, and non-transitory computer-readable medium described herein may further include operations, features, means, or instructions for configuring a first DMRS port group and a second DMRS port group with a same frequency resource allocation and time resource allocation and configuring the first DMRS port group and the second DMRS port group with different DMRS ports.

10 [0060] Some examples of the method, apparatuses, and non-transitory computer-readable medium described herein may further include operations, features, means, or instructions for configuring a first DMRS port group and a second DMRS port group with a different frequency resource allocation and time resource allocation, where the first DMRS port group may be active in the frequency resource allocation and time resource allocation associated
15 with the first DMRS port group and the second DMRS port group may be active in the frequency resource allocation and time resource allocation associated with the second DMRS port group.

[0061] Some examples of the method, apparatuses, and non-transitory computer-readable medium described herein may further include operations, features, means, or instructions for
20 configuring a first DMRS port group and a second DMRS port group to share one or more DMRS ports, but with a different frequency resource allocation and time resource allocation, where at least one of a first QCL information, a first rate matching configuration, or a combination thereof, may be applied to the shared one or more DMRS ports using a frequency resource allocation and time resource allocation associated with the first DMRS
25 port group and where at least one of a second QCL information, a second rate matching configuration, or a combination thereof, may be applied to the shared one or more DMRS ports using a frequency resource allocation and time resource allocation associated with the second DMRS port group.

[0062] In some examples of the method, apparatuses, and non-transitory computer-
30 readable medium described herein, the DCI message may include operations, features,

means, or instructions for transmitting the second DCI message that includes an indication of a second DMRS port group-specific parameter set.

5 [0063] In some examples of the method, apparatuses, and non-transitory computer-readable medium described herein, the indication of the resource includes an indication of a starting resource block for receiving the second DCI message.

10 [0064] In some examples of the method, apparatuses, and non-transitory computer-readable medium described herein, the indication of the resource includes an indication of a component carrier identifier or a cell identifier, where the component carrier identifier or the cell identifier conveys an indication of a starting resource block for receiving the second DCI message.

[0065] In some examples of the method, apparatuses, and non-transitory computer-readable medium described herein, the indication of the resource includes an indicator indicating whether a resource allocation for the second DMRS port group may be the same as the resource allocation for the first DMRS port group.

15 [0066] In some examples of the method, apparatuses, and non-transitory computer-readable medium described herein, the mode indicator indicated in the DCI message conveys an indication of whether a resource allocation for the second DMRS port group may be the same as a resource allocation for the first DMRS port group.

20 [0067] Some examples of the method, apparatuses, and non-transitory computer-readable medium described herein may further include operations, features, means, or instructions for configuring, based on one or more bits or fields in the DCI message that explicitly indicate the resource for the second DCI message, a resource occupancy for the second DCI message.

25 [0068] Some examples of the method, apparatuses, and non-transitory computer-readable medium described herein may further include operations, features, means, or instructions for receiving a signal indicating that at least the second DCI message or at least one DMRS port of the second DMRS port group associated with different portions of a TB of a CW could not be decoded and performing, based on the signal and the transmission scheme, a retransmission of the second DCI message or the different portion of the TB.

30 [0069] Some examples of the method, apparatuses, and non-transitory computer-readable medium described herein may further include operations, features, means, or instructions for

receiving a first signal indicating a decoding result of a TB associated with the first DMRS port group.

[0070] Some examples of the method, apparatuses, and non-transitory computer-readable medium described herein may further include operations, features, means, or instructions for receiving a second signal indicating that at least the second DCI message or a TB associated with the second DMRS port group could not be decoded and performing, based on the second signal and the transmission scheme, a retransmission of the second DCI message or the TB associated with the second DMRS port group.

[0071] Some examples of the method, apparatuses, and non-transitory computer-readable medium described herein may further include operations, features, means, or instructions for receiving a first signal indicating a decoding result of the TB.

[0072] Some examples of the method, apparatuses, and non-transitory computer-readable medium described herein may further include operations, features, means, or instructions for receiving a second signal indicating that the second DCI message could not be decoded and performing a retransmission of the second DCI message.

BRIEF DESCRIPTION OF THE DRAWINGS

[0073] FIG. 1 illustrates an example of a system for wireless communications that supports single and multi-stage downlink control information (DCI) design for multiple transceiver nodes in accordance with aspects of the present disclosure.

[0074] FIG. 2 illustrates an example of a wireless communication system that supports single and multi-stage DCI design for multiple transceiver nodes in accordance with aspects of the present disclosure.

[0075] FIG. 3 illustrates an example of a DCI configuration that supports single and multi-stage DCI design for multiple transceiver nodes in accordance with aspects of the present disclosure.

[0076] FIG. 4 illustrates an example of a DCI configuration that supports single and multi-stage dcI design for multiple transceiver nodes in accordance with aspects of the present disclosure.

[0077] FIG. 5 illustrates an example of a DCI configuration that supports single and multi-stage DCI design for multiple transceiver nodes in accordance with aspects of the present disclosure.

5 [0078] FIG. 6 illustrates an example of a multi-DCI configuration that supports single and multi-stage DCI design for multiple transceiver nodes in accordance with aspects of the present disclosure.

[0079] FIG. 7 illustrates an example of a multi-DCI configuration that supports single and multi-stage DCI design for multiple transceiver nodes in accordance with aspects of the present disclosure.

10 [0080] FIG. 8 illustrates an example of a process that supports single and multi-stage DCI design for multiple transceiver nodes in accordance with aspects of the present disclosure.

[0081] FIGs. 9 and 10 show block diagrams of devices that support single and multi-stage DCI design for multiple transceiver nodes in accordance with aspects of the present disclosure.

15 [0082] FIG. 11 shows a block diagram of a communications manager that supports single and multi-stage DCI design for multiple transceiver nodes in accordance with aspects of the present disclosure.

[0083] FIG. 12 shows a diagram of a system including a device that supports single and multi-stage DCI design for multiple transceiver nodes in accordance with aspects of the present disclosure.

20

[0084] FIGs. 13 and 14 show block diagrams of devices that support single and multi-stage DCI design for multiple transceiver nodes in accordance with aspects of the present disclosure.

[0085] FIG. 15 shows a block diagram of a communications manager that supports single and multi-stage DCI design for multiple transceiver nodes in accordance with aspects of the present disclosure.

25

[0086] FIG. 16 shows a diagram of a system including a device that supports single and multi-stage DCI design for multiple transceiver nodes in accordance with aspects of the present disclosure.

[0087] FIGs. 17 and 18 show flowcharts illustrating methods that support single and multi-stage DCI design for multiple transceiver nodes in accordance with aspects of the present disclosure.

DETAILED DESCRIPTION

5 [0088] Wireless communication systems may use a downlink control information (DCI) message as a grant to schedule communications between a base station and user equipment (UE). The communications may include using different transmission schemes to support the communications between the UE and base station. In some examples, the transmission schemes may support transmissions from multiple transmission/reception points (TRPS),
10 which may also be referred to as a transceiver nodes. That is, multiple transceiver nodes may be associated with a base station, or with multiple base stations, where each transceiver node transmits the same or different information to the UE during a downlink transmission. In some aspects, a transmission scheme may refer to an association between one or more demodulation reference signal (DMRS) port groups and one or more codewords. Examples of
15 transmission schemes include, but are not limited to, each transceiver node transmitting a unique codeword to the UE during the downlink transmission, each transceiver node transmitting a different part of the same codeword to the UE, and/or each transceiver node transmitting a different version of the same codeword to the UE. Typically, conventional techniques require a separate downlink grant, e.g., a DCI indicating resources for the
20 downlink transmission from the respective transceiver node. However, this approach is inefficient and involves increased overhead in terms of signaling, resources, and the like.

[0089] Aspects of the disclosure are initially described in the context of a wireless communications system. Aspects of the described techniques provide a design for a single stage or multi-stage DCI that supports downlink transmissions for multiple transceiver nodes
25 or TRPs. For example, the base station may transmit a DCI message to the UE that configures a downlink transmission of one or more codewords. Generally, each codeword may be associated with one or more DMRS port groups. In some examples, the DCI message may carry or otherwise provide an indication of a mode indicator that can be used by the UE to determine the transmission scheme for the downlink transmission. In some examples, the
30 DCI message may also carry or otherwise convey an indication of a common parameter set for the DMRS port groups as well as one or more DMRS port groups specific parameter sets.

The UE may use this information, along with the transmission scheme information, to determine quasi-co-located (QCL) information, a rate matching configuration, and/or a resource allocation for a DMRS port group to use during the downlink transmission. In a multi-stage DCI design, the first DCI message may include the common parameter set for the DMRS port groups, a first DMRS port groups specific parameter set, and an indication of a resource for receiving a second DCI message. The UE may receive the second DCI message and use a second DMRS port groups specific parameter set to determine the QCL information, the rate matching configuration, and/or the resource allocation for the DMRS port group associated with the second DCI message.

10 [0090] In some aspects, the indication of the DMRS ports configuration and/or the DMRS group configuration may be provided in the common parameter set and/or the DMRS port group specific parameter set(s). For example, when the indication of the DMRS ports is carried or conveyed in the common parameter set, the DMRS port configuration information may also be provided in the common parameter set. In this case, the grouping of information
15 may be provided in higher layer signaling, e.g., radio resource control (RRC) signaling, medium access control (MAC) control element (CE) signaling, and the like. For example, if there are two DMRS port groups, RRC/MAC CE signaling may configure two bitmaps, each bitmap with 12 bits. The first bitmap may be used to indicate which DMRS port(s) out of the 12 DMRS ports belong to the first DMRS port group. The second bitmap may be used to
20 convey the indication of the second DMRS port group. By providing the DMRS ports configuration in the common parameter set, the UE may know which DMRS ports are associated with a DMRS port group 1 and which DMRS ports are associated with DMRS port group 2 using the RRC/MAC CE configuration.

25 [0091] Aspects of the disclosure are further illustrated by and described with reference to apparatus diagrams, system diagrams, and flowcharts that relate to single and multi-stage DCI design for multiple transceiver nodes.

[0092] FIG. 1 illustrates an example of a wireless communications system 100 that supports single and multi-stage DCI design for multiple transceiver nodes in accordance with aspects of the present disclosure. The wireless communications system 100 includes base stations 105, UEs 115, and a core network 130. In some examples, the wireless
30 communications system 100 may be a Long Term Evolution (LTE) network, an LTE-

Advanced (LTE-A) network, an LTE-A Pro network, or a New Radio (NR) network. In some cases, wireless communications system 100 may support enhanced broadband communications, ultra-reliable (e.g., mission critical) communications, low latency communications, or communications with low-cost and low-complexity devices.

5 [0093] Base stations 105 may wirelessly communicate with UEs 115 via one or more base station antennas. Base stations 105 described herein may include or may be referred to by those skilled in the art as a base transceiver station, a radio base station, an access point, a radio transceiver, a NodeB, an eNodeB (eNB), a next-generation Node B or giga-nodeB (either of which may be referred to as a gNB), a Home NodeB, a Home eNodeB, or some
10 other suitable terminology. Wireless communications system 100 may include base stations 105 of different types (e.g., macro or small cell base stations). The UEs 115 described herein may be able to communicate with various types of base stations 105 and network equipment including macro eNBs, small cell eNBs, gNBs, relay base stations, and the like.

[0094] Each base station 105 may be associated with a particular geographic coverage
15 area 110 in which communications with various UEs 115 is supported. Each base station 105 may provide communication coverage for a respective geographic coverage area 110 via communication links 125, and communication links 125 between a base station 105 and a UE 115 may utilize one or more carriers. Communication links 125 shown in wireless
20 communications system 100 may include uplink transmissions from a UE 115 to a base station 105, or downlink transmissions from a base station 105 to a UE 115. Downlink transmissions may also be called forward link transmissions while uplink transmissions may also be called reverse link transmissions.

[0095] The geographic coverage area 110 for a base station 105 may be divided into
25 sectors making up only a portion of the geographic coverage area 110, and each sector may be associated with a cell. For example, each base station 105 may provide communication coverage for a macro cell, a small cell, a hot spot, or other types of cells, or various combinations thereof. In some examples, a base station 105 may be movable and therefore provide communication coverage for a moving geographic coverage area 110. In some
30 examples, different geographic coverage areas 110 associated with different technologies may overlap, and overlapping geographic coverage areas 110 associated with different technologies may be supported by the same base station 105 or by different base stations 105.

The wireless communications system 100 may include, for example, a heterogeneous LTE/LTE-A/LTE-A Pro or NR network in which different types of base stations 105 provide coverage for various geographic coverage areas 110.

[0096] The term “cell” refers to a logical communication entity used for communication with a base station 105 (e.g., over a carrier), and may be associated with an identifier for distinguishing neighboring cells (e.g., a physical cell identifier (PCID), a virtual cell identifier (VCID)) operating via the same or a different carrier. In some examples, a carrier may support multiple cells, and different cells may be configured according to different protocol types (e.g., machine-type communication (MTC), narrowband Internet-of-Things (NB-IoT), enhanced mobile broadband (eMBB), or others) that may provide access for different types of devices. In some cases, the term “cell” may refer to a portion of a geographic coverage area 110 (e.g., a sector) over which the logical entity operates.

[0097] UEs 115 may be dispersed throughout the wireless communications system 100, and each UE 115 may be stationary or mobile. A UE 115 may also be referred to as a mobile device, a wireless device, a remote device, a handheld device, or a subscriber device, or some other suitable terminology, where the “device” may also be referred to as a unit, a station, a terminal, or a client. A UE 115 may also be a personal electronic device such as a cellular phone, a personal digital assistant (PDA), a tablet computer, a laptop computer, or a personal computer. In some examples, a UE 115 may also refer to a wireless local loop (WLL) station, an Internet of Things (IoT) device, an Internet of Everything (IoE) device, or an MTC device, or the like, which may be implemented in various articles such as appliances, vehicles, meters, or the like.

[0098] Some UEs 115, such as MTC or IoT devices, may be low cost or low complexity devices, and may provide for automated communication between machines (e.g., via Machine-to-Machine (M2M) communication). M2M communication or MTC may refer to data communication technologies that allow devices to communicate with one another or a base station 105 without human intervention. In some examples, M2M communication or MTC may include communications from devices that integrate sensors or meters to measure or capture information and relay that information to a central server or application program that can make use of the information or present the information to humans interacting with the program or application. Some UEs 115 may be designed to collect information or enable

automated behavior of machines. Examples of applications for MTC devices include smart metering, inventory monitoring, water level monitoring, equipment monitoring, healthcare monitoring, wildlife monitoring, weather and geological event monitoring, fleet management and tracking, remote security sensing, physical access control, and transaction-based business charging.

[0099] Some UEs 115 may be configured to employ operating modes that reduce power consumption, such as half-duplex communications (e.g., a mode that supports one-way communication via transmission or reception, but not transmission and reception simultaneously). In some examples half-duplex communications may be performed at a reduced peak rate. Other power conservation techniques for UEs 115 include entering a power saving “deep sleep” mode when not engaging in active communications, or operating over a limited bandwidth (e.g., according to narrowband communications). In some cases, UEs 115 may be designed to support critical functions (e.g., mission critical functions), and a wireless communications system 100 may be configured to provide ultra-reliable communications for these functions.

[0100] In some cases, a UE 115 may also be able to communicate directly with other UEs 115 (e.g., using a peer-to-peer (P2P) or device-to-device (D2D) protocol). One or more of a group of UEs 115 utilizing D2D communications may be within the geographic coverage area 110 of a base station 105. Other UEs 115 in such a group may be outside the geographic coverage area 110 of a base station 105, or be otherwise unable to receive transmissions from a base station 105. In some cases, groups of UEs 115 communicating via D2D communications may utilize a one-to-many (1:M) system in which each UE 115 transmits to every other UE 115 in the group. In some cases, a base station 105 facilitates the scheduling of resources for D2D communications. In other cases, D2D communications are carried out between UEs 115 without the involvement of a base station 105.

[0101] Base stations 105 may communicate with the core network 130 and with one another. For example, base stations 105 may interface with the core network 130 through backhaul links 132 (e.g., via an S1, N2, N3, or another interface). Base stations 105 may communicate with one another over backhaul links 134 (e.g., via an X2, Xn, or other interface) either directly (e.g., directly between base stations 105) or indirectly (e.g., via core network 130).

[0102] The core network 130 may provide user authentication, access authorization, tracking, Internet Protocol (IP) connectivity, and other access, routing, or mobility functions. The core network 130 may be an evolved packet core (EPC), which may include at least one mobility management entity (MME), at least one serving gateway (S-GW), and at least one Packet Data Network (PDN) gateway (P-GW). The MME may manage non-access stratum (e.g., control plane) functions such as mobility, authentication, and bearer management for UEs 115 served by base stations 105 associated with the EPC. User IP packets may be transferred through the S-GW, which itself may be connected to the P-GW. The P-GW may provide IP address allocation as well as other functions. The P-GW may be connected to the network operators IP services. The operators IP services may include access to the Internet, Intranet(s), an IP Multimedia Subsystem (IMS), or a Packet-Switched (PS) Streaming Service.

[0103] At least some of the network devices, such as a base station 105, may include subcomponents such as an access network entity, which may be an example of an access node controller (ANC). Each access network entity may communicate with UEs 115 through a number of other access network transmission entities, which may be referred to as a radio head, a smart radio head, or a transmission/reception point (TRP). In some configurations, various functions of each access network entity or base station 105 may be distributed across various network devices (e.g., radio heads and access network controllers) or consolidated into a single network device (e.g., a base station 105).

[0104] Wireless communications system 100 may operate using one or more frequency bands, typically in the range of 300 MHz to 300 GHz. Generally, the region from 300 MHz to 3 GHz is known as the ultra-high frequency (UHF) region or decimeter band, since the wavelengths range from approximately one decimeter to one meter in length. UHF waves may be blocked or redirected by buildings and environmental features. However, the waves may penetrate structures sufficiently for a macro cell to provide service to UEs 115 located indoors. Transmission of UHF waves may be associated with smaller antennas and shorter range (e.g., less than 100 km) compared to transmission using the smaller frequencies and longer waves of the high frequency (HF) or very high frequency (VHF) portion of the spectrum below 300 MHz.

[0105] Wireless communications system 100 may also operate in a super high frequency (SHF) region using frequency bands from 3 GHz to 30 GHz, also known as the centimeter

band. The SHF region includes bands such as the 5 GHz industrial, scientific, and medical (ISM) bands, which may be used opportunistically by devices that can tolerate interference from other users.

[0106] Wireless communications system 100 may also operate in an extremely high frequency (EHF) region of the spectrum (e.g., from 30 GHz to 300 GHz), also known as the millimeter band. In some examples, wireless communications system 100 may support millimeter wave (mmW) communications between UEs 115 and base stations 105, and EHF antennas of the respective devices may be even smaller and more closely spaced than UHF antennas. In some cases, this may facilitate use of antenna arrays within a UE 115. However, the propagation of EHF transmissions may be subject to even greater atmospheric attenuation and shorter range than SHF or UHF transmissions. Techniques disclosed herein may be employed across transmissions that use one or more different frequency regions, and designated use of bands across these frequency regions may differ by country or regulating body.

[0107] In some cases, wireless communications system 100 may utilize both licensed and unlicensed radio frequency spectrum bands. For example, wireless communications system 100 may employ License Assisted Access (LAA), LTE-Unlicensed (LTE-U) radio access technology, or NR technology in an unlicensed band such as the 5 GHz ISM band. When operating in unlicensed radio frequency spectrum bands, wireless devices such as base stations 105 and UEs 115 may employ listen-before-talk (LBT) procedures to ensure a frequency channel is clear before transmitting data. In some cases, operations in unlicensed bands may be based on a CA configuration in conjunction with CCs operating in a licensed band (e.g., LAA). Operations in unlicensed spectrum may include downlink transmissions, uplink transmissions, peer-to-peer transmissions, or a combination of these. Duplexing in unlicensed spectrum may be based on frequency division duplexing (FDD), time division duplexing (TDD), or a combination of both.

[0108] In some examples, base station 105 or UE 115 may be equipped with multiple antennas, which may be used to employ techniques such as transmit diversity, receive diversity, multiple-input multiple-output (MIMO) communications, or beamforming. For example, wireless communications system 100 may use a transmission scheme between a transmitting device (e.g., a base station 105) and a receiving device (e.g., a UE 115), where

the transmitting device is equipped with multiple antennas and the receiving devices are equipped with one or more antennas. MIMO communications may employ multipath signal propagation to increase the spectral efficiency by transmitting or receiving multiple signals via different spatial layers, which may be referred to as spatial multiplexing. The multiple signals may, for example, be transmitted by the transmitting device via different antennas or different combinations of antennas. Likewise, the multiple signals may be received by the receiving device via different antennas or different combinations of antennas. Each of the multiple signals may be referred to as a separate spatial stream, and may carry bits associated with the same data stream (e.g., the same codeword) or different data streams. Different spatial layers may be associated with different antenna ports used for channel measurement and reporting. MIMO techniques include single-user MIMO (SU-MIMO) where multiple spatial layers are transmitted to the same receiving device, and multiple-user MIMO (MU-MIMO) where multiple spatial layers are transmitted to multiple devices.

[0109] Beamforming, which may also be referred to as spatial filtering, directional transmission, or directional reception, is a signal processing technique that may be used at a transmitting device or a receiving device (e.g., a base station 105 or a UE 115) to shape or steer an antenna beam (e.g., a transmit beam or receive beam) along a spatial path between the transmitting device and the receiving device. Beamforming may be achieved by combining the signals communicated via antenna elements of an antenna array such that signals propagating at particular orientations with respect to an antenna array experience constructive interference while others experience destructive interference. The adjustment of signals communicated via the antenna elements may include a transmitting device or a receiving device applying certain amplitude and phase offsets to signals carried via each of the antenna elements associated with the device. The adjustments associated with each of the antenna elements may be defined by a beamforming weight set associated with a particular orientation (e.g., with respect to the antenna array of the transmitting device or receiving device, or with respect to some other orientation).

[0110] In one example, a base station 105 may use multiple antennas or antenna arrays to conduct beamforming operations for directional communications with a UE 115. For instance, some signals (e.g. synchronization signals, reference signals, beam selection signals, or other control signals) may be transmitted by a base station 105 multiple times in different directions, which may include a signal being transmitted according to different beamforming

weight sets associated with different directions of transmission. Transmissions in different beam directions may be used to identify (e.g., by the base station 105 or a receiving device, such as a UE 115) a beam direction for subsequent transmission and/or reception by the base station 105. Some signals, such as data signals associated with a particular receiving device, may be transmitted by a base station 105 in a single beam direction (e.g., a direction associated with the receiving device, such as a UE 115). In some examples, the beam direction associated with transmissions along a single beam direction may be determined based at least in part on a signal that was transmitted in different beam directions. For example, a UE 115 may receive one or more of the signals transmitted by the base station 105 in different directions, and the UE 115 may report to the base station 105 an indication of the signal it received with a highest signal quality, or an otherwise acceptable signal quality. Although these techniques are described with reference to signals transmitted in one or more directions by a base station 105, a UE 115 may employ similar techniques for transmitting signals multiple times in different directions (e.g., for identifying a beam direction for subsequent transmission or reception by the UE 115), or transmitting a signal in a single direction (e.g., for transmitting data to a receiving device).

[0111] A receiving device (e.g., a UE 115, which may be an example of a mmW receiving device) may try multiple receive beams when receiving various signals from the base station 105, such as synchronization signals, reference signals, beam selection signals, or other control signals. For example, a receiving device may try multiple receive directions by receiving via different antenna subarrays, by processing received signals according to different antenna subarrays, by receiving according to different receive beamforming weight sets applied to signals received at a plurality of antenna elements of an antenna array, or by processing received signals according to different receive beamforming weight sets applied to signals received at a plurality of antenna elements of an antenna array, any of which may be referred to as “listening” according to different receive beams or receive directions. In some examples a receiving device may use a single receive beam to receive along a single beam direction (e.g., when receiving a data signal). The single receive beam may be aligned in a beam direction determined based at least in part on listening according to different receive beam directions (e.g., a beam direction determined to have a highest signal strength, highest signal-to-noise ratio, or otherwise acceptable signal quality based at least in part on listening according to multiple beam directions).

[0112] In some cases, the antennas of a base station 105 or UE 115 may be located within one or more antenna arrays, which may support MIMO operations, or transmit or receive beamforming. For example, one or more base station antennas or antenna arrays may be co-located at an antenna assembly, such as an antenna tower. In some cases, antennas or antenna arrays associated with a base station 105 may be located in diverse geographic locations. A base station 105 may have an antenna array with a number of rows and columns of antenna ports that the base station 105 may use to support beamforming of communications with a UE 115. Likewise, a UE 115 may have one or more antenna arrays that may support various MIMO or beamforming operations.

10 [0113] In some cases, wireless communications system 100 may be a packet-based network that operate according to a layered protocol stack. In the user plane, communications at the bearer or Packet Data Convergence Protocol (PDCP) layer may be IP-based. A Radio Link Control (RLC) layer may in some cases perform packet segmentation and reassembly to communicate over logical channels. A Medium Access Control (MAC) layer may perform priority handling and multiplexing of logical channels into transport channels. The MAC layer may also use hybrid automatic repeat request (HARQ) to provide retransmission at the MAC layer to improve link efficiency. In the control plane, the Radio Resource Control (RRC) protocol layer may provide establishment, configuration, and maintenance of an RRC connection between a UE 115 and a base station 105 or core network 130 supporting radio bearers for user plane data. At the Physical (PHY) layer, transport channels may be mapped to physical channels.

[0114] In some cases, UEs 115 and base stations 105 may support retransmissions of data to increase the likelihood that data is received successfully. HARQ feedback is one technique of increasing the likelihood that data is received correctly over a communication link 125. HARQ may include a combination of error detection (e.g., using a cyclic redundancy check (CRC)), forward error correction (FEC), and retransmission (e.g., automatic repeat request (ARQ)). HARQ may improve throughput at the MAC layer in poor radio conditions (e.g., signal-to-noise conditions). In some cases, a wireless device may support same-slot HARQ feedback, where the device may provide HARQ feedback in a specific slot for data received in a previous symbol in the slot. In other cases, the device may provide HARQ feedback in a subsequent slot, or according to some other time interval.

[0115] Time intervals in LTE or NR may be expressed in multiples of a basic time unit, which may, for example, refer to a sampling period of $T_s = 1/30,720,000$ seconds. Time intervals of a communications resource may be organized according to radio frames each having a duration of 10 milliseconds (ms), where the frame period may be expressed as $T_f = 307,200 T_s$. The radio frames may be identified by a system frame number (SFN) ranging from 0 to 1023. Each frame may include 10 subframes numbered from 0 to 9, and each subframe may have a duration of 1 ms. A subframe may be further divided into 2 slots each having a duration of 0.5 ms, and each slot may contain 6 or 7 modulation symbol periods (e.g., depending on the length of the cyclic prefix prepended to each symbol period). Excluding the cyclic prefix, each symbol period may contain 2048 sampling periods. In some cases, a subframe may be the smallest scheduling unit of the wireless communications system 100, and may be referred to as a transmission time interval (TTI). In other cases, a smallest scheduling unit of the wireless communications system 100 may be shorter than a subframe or may be dynamically selected (e.g., in bursts of shortened TTIs (sTTIs) or in selected component carriers using sTTIs).

[0116] In some wireless communications systems, a slot may further be divided into multiple mini-slots containing one or more symbols. In some instances, a symbol of a mini-slot or a mini-slot may be the smallest unit of scheduling. Each symbol may vary in duration depending on the subcarrier spacing or frequency band of operation, for example. Further, some wireless communications systems may implement slot aggregation in which multiple slots or mini-slots are aggregated together and used for communication between a UE 115 and a base station 105.

[0117] The term “carrier” refers to a set of radio frequency spectrum resources having a defined physical layer structure for supporting communications over a communication link 125. For example, a carrier of a communication link 125 may include a portion of a radio frequency spectrum band that is operated according to physical layer channels for a given radio access technology. Each physical layer channel may carry user data, control information, or other signaling. A carrier may be associated with a pre-defined frequency channel (e.g., an E-UTRA absolute radio frequency channel number (EARFCN)), and may be positioned according to a channel raster for discovery by UEs 115. Carriers may be downlink or uplink (e.g., in an FDD mode), or be configured to carry downlink and uplink communications (e.g., in a TDD mode). In some examples, signal waveforms transmitted

over a carrier may be made up of multiple sub-carriers (e.g., using multi-carrier modulation (MCM) techniques such as OFDM or DFT-s-OFDM).

[0118] The organizational structure of the carriers may be different for different radio access technologies (e.g., LTE, LTE-A, LTE-A Pro, NR, etc.). For example, communications over a carrier may be organized according to TTIs or slots, each of which may include user data as well as control information or signaling to support decoding the user data. A carrier may also include dedicated acquisition signaling (e.g., synchronization signals or system information, etc.) and control signaling that coordinates operation for the carrier. In some examples (e.g., in a carrier aggregation configuration), a carrier may also have acquisition signaling or control signaling that coordinates operations for other carriers.

[0119] Physical channels may be multiplexed on a carrier according to various techniques. A physical control channel and a physical data channel may be multiplexed on a downlink carrier, for example, using time division multiplexing (TDM) techniques, frequency division multiplexing (FDM) techniques, or hybrid TDM-FDM techniques. In some examples, control information transmitted in a physical control channel may be distributed between different control regions in a cascaded manner (e.g., between a common control region or common search space and one or more UE-specific control regions or UE-specific search spaces).

[0120] A carrier may be associated with a particular bandwidth of the radio frequency spectrum, and in some examples the carrier bandwidth may be referred to as a “system bandwidth” of the carrier or the wireless communications system 100. For example, the carrier bandwidth may be one of a number of predetermined bandwidths for carriers of a particular radio access technology (e.g., 1.4, 3, 5, 10, 15, 20, 40, or 80 MHz). In some examples, each served UE 115 may be configured for operating over portions or all of the carrier bandwidth. In other examples, some UEs 115 may be configured for operation using a narrowband protocol type that is associated with a predefined portion or range (e.g., set of subcarriers or RBs) within a carrier (e.g., “in-band” deployment of a narrowband protocol type).

[0121] In a system employing MCM techniques, a resource element may consist of one symbol period (e.g., a duration of one modulation symbol) and one subcarrier, where the symbol period and subcarrier spacing are inversely related. The number of bits carried by each resource element may depend on the modulation scheme (e.g., the order of the

modulation scheme). Thus, the more resource elements that a UE 115 receives and the higher the order of the modulation scheme, the higher the data rate may be for the UE 115. In MIMO systems, a wireless communications resource may refer to a combination of a radio frequency spectrum resource, a time resource, and a spatial resource (e.g., spatial layers), and the use of multiple spatial layers may further increase the data rate for communications with a UE 115.

[0122] Devices of the wireless communications system 100 (e.g., base stations 105 or UEs 115) may have a hardware configuration that supports communications over a particular carrier bandwidth, or may be configurable to support communications over one of a set of carrier bandwidths. In some examples, the wireless communications system 100 may include base stations 105 and/or UEs 115 that can support simultaneous communications via carriers associated with more than one different carrier bandwidth.

[0123] Wireless communications system 100 may support communication with a UE 115 on multiple cells or carriers, a feature which may be referred to as carrier aggregation (CA) or multi-carrier operation. A UE 115 may be configured with multiple downlink CCs and one or more uplink CCs according to a carrier aggregation configuration. Carrier aggregation may be used with both FDD and TDD component carriers.

[0124] In some cases, wireless communications system 100 may utilize enhanced component carriers (eCCs). An eCC may be characterized by one or more features including wider carrier or frequency channel bandwidth, shorter symbol duration, shorter TTI duration, or modified control channel configuration. In some cases, an eCC may be associated with a carrier aggregation configuration or a dual connectivity configuration (e.g., when multiple serving cells have a suboptimal or non-ideal backhaul link). An eCC may also be configured for use in unlicensed spectrum or shared spectrum (e.g., where more than one operator is allowed to use the spectrum). An eCC characterized by wide carrier bandwidth may include one or more segments that may be utilized by UEs 115 that are not capable of monitoring the whole carrier bandwidth or are otherwise configured to use a limited carrier bandwidth (e.g., to conserve power).

[0125] In some cases, an eCC may utilize a different symbol duration than other CCs, which may include use of a reduced symbol duration as compared with symbol durations of the other CCs. A shorter symbol duration may be associated with increased spacing between

adjacent subcarriers. A device, such as a UE 115 or base station 105, utilizing eCCs may transmit wideband signals (e.g., according to frequency channel or carrier bandwidths of 20, 40, 60, 80 MHz, etc.) at reduced symbol durations (e.g., 16.67 microseconds). A TTI in eCC may consist of one or multiple symbol periods. In some cases, the TTI duration (that is, the number of symbol periods in a TTI) may be variable.

[0126] Wireless communications systems such as an NR system may utilize any combination of licensed, shared, and unlicensed spectrum bands, among others. The flexibility of eCC symbol duration and subcarrier spacing may allow for the use of eCC across multiple spectrums. In some examples, NR shared spectrum may increase spectrum utilization and spectral efficiency, specifically through dynamic vertical (e.g., across the frequency domain) and horizontal (e.g., across the time domain) sharing of resources.

[0127] In some aspects, a UE 115 may receive a DCI message configuring a downlink transmission of one or more codewords associated with one or more DMRS port groups. The DCI message may include a mode indicator, a common parameter set for the one or more DMRS port groups, and one or more DMRS port group-specific parameter set. The UE 115 may determine, based at least in part on the mode indicator, a transmission scheme for the downlink transmission. The transmission scheme may include an association between the one or more DMRS port groups and the one or more codewords. The UE 115 may determine, based at least in part on at least one of the common parameter sets for the one or more DMRS port groups, the one or more DMRS port group-specific parameter set, or a combination thereof, at least one of QCL information, a rate matching configuration, a resource allocation, or a combination thereof, for at least one DMRS port group.

[0128] FIG. 2 illustrates an example of a wireless communication system 200 that supports single and multi-stage DCI design for multiple transceiver nodes in accordance with aspects of the present disclosure. In some examples, wireless communication system 200 may implement aspects of wireless communication system 100. Wireless communication system 200 may include a first transceiver node 205-a, a second transceiver node 205-b, and a UE 210, which may be examples of the corresponding devices described herein. In some aspects, the first transceiver node 205-a may also be referred to as TRP 1 or simply TRP1. In some aspects, the second transceiver node 205-b may also be referred to as TRP 2 or simply TRP2.

[0129] Wireless communication system 200 may support downlink transmissions to UE 210 from both the first transceiver node 205-a and the second transceiver node 205-b. Generally, the downlink transmissions may be communicated according to one or more transmission schemes. In some aspects, the transmission scheme (which may also be referred to as different “cases”) may include each of transceiver nodes 205 communicating different codewords to UE 210 (e.g., case 1), communicating different portions (e.g., different layers of the same codeword, different parts of the same codeword, etc.) of the same codeword to UE 210 (e.g., case 2), and/or communicating different versions of the same codeword to UE 210 (e.g., case 3). Generally, the codeword may refer to a set of information bits that are encoded, modulated, and transmitted to UE 210. Generally, the downlink transmissions to UE 210 may be communicated using the same resources or using different resources between the transceiver nodes 205.

[0130] Conventional techniques may require each transceiver node 205 to separately grant its own downlink transmission to UE 210. For example, conventional techniques require the first transceiver node 205-a to signal a grant message to UE 210 that identifies resources to use for the downlink transmission from the first transceiver node 205-a and also require the second transceiver node 205-b to signal a separate grant message to UE 210 that identifies resources to use for the downlink transmission from the second transceiver node 205-b. However, aspects of the described techniques provide for a single stage and/or a multi-stage DCI design with a mode indicator that supports the different transmission schemes from transceiver nodes 205-a and 205-b.

[0131] For example, UE 210 may receive a DCI message from either transceiver node 205-a or 205-b that configures the downlink transmission of one or more codewords to UE 210. Generally, each codeword may be associated with one or more DMRS port groups. In some examples, the DCI message may carry or otherwise convey an indication of the mode indicator, a parameter set that is common for each of the one or more DMRS port groups, and one or more parameter sets that are specific to a particular DMRS port group.

[0132] In some aspects, UE 210 may identify the DCI format (e.g., a format of the DCI message) using, for example, blind detection based on the payload size of the DCI message and a maximum number of codewords that are scheduled by the DCI message. In the example where there are two transceiver nodes 205 performing a downlink transmission to

UE 210, there may be a hypothesis of four formats for the DCI message. The first hypothesis may be associated with a maximum number of codewords being one, for a first format (format 1) being used for the DCI message. A second hypothesis may be associated with a maximum number of codewords being two, with the first format being used for the DCI message. A third hypothesis may be associated with a maximum number of codewords being one, with a second format (format 2) being used for the DCI message. A fourth hypothesis may be associated with a maximum number of codewords being two, and the second format being used for the DCI message. In some examples, there may be more than two transceiver nodes 205 performing downlink transmissions to UE 210.

10 **[0133]** UE 210 may use the mode indicator to determine the transmission scheme being used for the downlink transmission (e.g., to identify case 1, case 2, or case 3). In some aspects, the transmission scheme is, at least in some aspects, an association between the one or more DMRS port groups and the one or more codewords. In some examples, each DMRS port group may be associated with a different transceiver node 205, such that UE 210
15 determining or otherwise identifying the DMRS port group signals an indication of which transceiver node 205 is communicating the associated codeword. In other aspects, a DMRS port group may be shared between the multiple transceiver nodes 205.

[0134] In some aspects, UE 210 may determine the transmission scheme based on the mode indicator where the mode indicator is implicitly conveyed in the DCI message. For
20 example, the mode indicator may be signaled in the DCI message via CRC scrambling, e.g., each case (and corresponding mode indicator) may correspond to the particular CRC scrambling sequence. Accordingly, UE 210 may try to descramble the DCI message using one or more CRC scrambling sequences, such that the CRC scrambling sequence that is successful during the decoding conveys the indication of the mode indicator. In some aspects,
25 the mode indicator in the DCI message may be explicitly indicated via a field or bits.

[0135] In some examples, the number of bits or bit width of the mode indicator may be related to the total number of transmission schemes. For example, this may be dependent upon the maximum number of codewords being communicated during the downlink transmission, e.g., if the maximum number of codewords is one, only one transmission
30 scheme with only one codeword can be configured by the DCI message.

[0136] In some aspects, UE 210 may be configured with the set of available transmission schemes, e.g., via higher layer signaling, such as RRC signaling, MAC control element (CE) signaling, and the like. In this example, the mode indicator provided in the DCI message may signal which transmission scheme from the set of available transmission schemes are being used for the downlink transmission. For example, the mode indicator may simply be one or more bits set corresponding to a particular transmission scheme, may indicate an index associated with a particular transmission scheme, and the like.

[0137] In some aspects, UE 210 may use the parameter sets (e.g., the parameter set that is common for the DMRS port groups as well as any parameter set(s) that is specific to a particular DMRS port group) to identify or otherwise determine additional configuration information for the downlink transmission. For example, UE 210 may determine or otherwise identify QCL information, a rate matching configuration, and/or a resource allocation for each DMRS port group.

[0138] In some aspects, UE 210 may use the DCI message (e.g., the mode indicator) to determine a mapping (e.g., the association) between a DMRS port group and a corresponding codeword. Broadly, each codeword may be mapped to a DMRS port group and resource allocation of the corresponding transceiver node 205, e.g., for cases 1 and 3. For example, a codeword may be mapped to a DMRS port group and resource allocation of transceiver node 205-a, and then mapped to a DMRS port group and resource allocation of transceiver node 205-b (e.g., DMRS port (TRP1) – frequency (TRP1) – Time (TRP1) – DMRS port (TRP2) – frequency (TRP2) – time (TRP2)), for case 2.

[0139] More particularly, the mapping may comprise mapping using the order across layers first, then across frequency, and finally across time. As one non-limiting example, a transport block may have eight bits, and there may be two layers/subcarriers/symbols, two subcarriers/symbols, and two symbols, where layer 1 and layer 2 have the same subcarriers and symbols. In this instance, the mapping may be: bit 1 to layer 1 of subcarrier 1 and symbol 1, then bit 2 to layer 2 of subcarrier 1 and symbol 1, then bit 3 to layer 1 of subcarrier 2 and symbol 1, then bit 4 to layer 2 of subcarrier 2 and symbol 1, then bit 5 to layer 1 of subcarrier 1 and symbol 2, then bit 6 to layer 2 of subcarrier 1 and symbol 2, then bit 7 to layer 1 of subcarrier 2 and symbol 2, and then bit 8 to layer 2 of subcarrier 2 and symbol 2.

[0140] In the instance where layer 1 and layer 2 use different subcarriers, but the same symbols, the layer-frequency-time order after aggregating may be (assuming layer 1 uses subcarriers 1 and 2 and layer 2 use subcarriers 3 and 4): bit 1 to layer 1 of subcarrier 1 and symbol 1, then bit 2 to layer 1 of subcarrier 2 and symbol 1, then bit 3 to layer 2 of subcarrier 3 and symbol 1, then bit 4 to layer 2 of subcarrier 4 and symbol 1, then bit 5 to layer 1 of subcarrier 1 and symbol 2, then bit 6 to layer 2 of subcarrier 2 and symbol 2, then bit 7 to layer 1 of subcarrier 3 and symbol 2, and then bit 8 to layer 2 of subcarrier 4 and symbol 2.

[0141] For cases 1 and 3, the mapping order is first within a TRP, and then across TRPs. Assuming layer 1 is from TRP1 and layer 2 is from TRP2, and both DMRS ports have the same resource allocations, the mapping may be: bit 1 to layer 1 of subcarrier 1 and symbol 1, then bit 2 to layer 1 of subcarrier 2 and symbol 1, then bit 3 to layer 1 of subcarrier 1 and symbol 2, then bit 4 to layer 1 of subcarrier 2 and symbol 2, then bit 5 to layer 2 of subcarrier 1 and symbol 1, then bit 6 to layer 2 of subcarrier 2 and symbol 1, then bit 7 to layer 2 of subcarrier 1 and symbol 2, and then bit 8 to layer 2 of subcarrier 2 and symbol 2.

[0142] In another example, UE 210 may aggregate the DMRS ports that support the same resource allocation of both TRP1 and TRP2 (e.g., for case 2), and then map the codeword to the aggregated ports and resource allocations. For example and in a format where the same resource allocation is used for both transceiver nodes 205 (e.g., TRP1 and TRP2), UE 210 may aggregate the DMRS ports for the first transceiver node 205-a, the DMRS ports for the second transceiver node 205-b, and then map the aggregated DMRS ports to the time/frequency resources allocation, e.g., DMRS port (TRP1) – DMRS port (TRP2) – frequency – time. In another example, where different resources are allocated, UE 210 may map the DMRS port group for the first transceiver node 205-a, to the frequency allocated to the first transceiver node 205-a, to the DMRS port group for the second transceiver node 205-b, to the frequency allocated to the second transceiver node 205-b, into the time resource, e.g., DMRS port (TRP1) – frequency (TRP1) – DMRS port (TRP2) – frequency (TRP2) – time.

[0143] In some aspects, when UE 210 determines that a first format is used for the DCI message and that the DCI message allocates the same resources to both transceiver nodes 205, UE 210 may determine that separate DMRS port groups are configured. In this example, the indication of the resource allocation may be provided in the common parameter set, e.g., in a portion of the first DCI message that indicates parameters common to all TRPs participating

in the downlink transmission. Generally, the different DMRS port groups may refer to DMRS port groups having different resources (e.g., frequency resource), using a different cover code (e.g., orthogonal cover code or cyclic shift), and/or a different DMRS sequence. When UE 210 determines that the second format is used for the DCI message and that the DCI message allocates different resources to both transceiver nodes 205, UE 210 may determine that the DMRS port group for the first transceiver node 205-a is only active in the resource allocation configured in the DMRS port group specific parameter set for the first transceiver node 205-a and that the DMRS port group of the second transceiver node 205-b is only active in the resource allocation configured in the DMRS port group specific parameter set for the second transceiver node 205-b. In another option, the DCI message uses a second format with different resource allocations. The UE 210 may determine that the QCL information is applied to the DMRS port groups on different resources.

[0144] In some aspects, the DCI message discussed above may be referred to as a first DCI message in a multi-stage DCI design. For example, the DCI message may carry or otherwise convey the indication of the mode indicator and the parameter set that is common to each of the DMRS port groups, a first DMRS port group specific parameter set (e.g., the parameter set for the first transceiver node 205-a), as well as an indication of a resource to be used for receiving a second DCI message (and the resource to be used for receiving a third DCI message when there are 3 transceiver nodes 205). For example, the indication of the resource for receiving the second DCI message may include an indication of, or information associated with, a first resource block position for the second DCI message (e.g., an explicit indication using one or more bits or fields, or an implicit indication). In the example where the indication of the resources is implicitly conveyed, this may be based on an identifier for a component carrier of a particular transceiver node 205. For example, the component carrier and/or cell identifier for each transceiver node 205 may be associated with, or otherwise correspond to, a specific starting resource block position for the second DCI message.

[0145] Like the DCI message in a single DCI case, the second DCI message may have more than one format. Broadly, when the resource allocation is the same between the transceiver nodes 205, a first format for the second DCI message may include no indication of a resource allocation, e.g., UE 210 may determine that the same resource allocation is used for both transceiver nodes 205 when no resource allocation is indicated in the second DCI message. When the resource allocation is different between the transceiver nodes 205, a

second format for the second DCI message may include a resource allocation being indicated for the second transceiver node 205-b. Accordingly, UE 210 may identify the format for the second DCI message based on whether a resource allocation indication is conveyed in the second DCI message.

5 [0146] In some aspects, there may be two ways for UE 210 to determine the format of the second DCI message. In one example method, UE 210 may determine the format of the second DCI message via the scheduling of second DCI message that is provided in the first DCI message. For example, the first DCI message may have a one bit indication to indicate whether the resource allocation of TRP1 and the resource allocation of TRP2 are the same or
10 not, based on which the UE 210 determines the payload of the second DCI message and the format of the second DCI message. That is, there may be an explicit indication of the resource allocation of the second DCI message in the scheduling of the second DCI message provided in the first DCI message. If a larger resource allocation for the second DCI message is provided, then it may mean the resource allocation of TRP2 is provided in the second DCI
15 message. If a smaller resource allocation for the second DCI message is provided, then it may mean the resource allocation of TRP2 is not provided in the second DCI message and it is the same as the resource allocation of TRP1. In another example method, UE 210 may determine the format (and/or payload) of the second DCI message via blind decoding, such as is described with respect to the single-stage DCI message discussed above.

20 [0147] In some aspects, once UE 210 determines a format for the second DCI message, UE 210 can calculate the payload size and the number of needed resources. For example, the first DCI message (e.g., in the scheduling indication for the second DCI message) may carry one bit that indicates whether the resource allocation of the second transceiver node 205-b is equal to or not equal to the resource allocation of the first transceiver node 205-a. In another
25 example, the mode indicator may include one or more bits or fields that may provide, or otherwise convey, an indication of whether the resource allocation for the first transceiver node 205-a is equal to or unequal to the resource allocation of the second transceiver node 205-b. In yet another example, the scheduling indication for the second DCI message carried in the first DCI message may explicitly indicate the resource occupancy for the second DCI
30 message.

[0148] In some aspects, determining the scheduling of a second DCI message may include UE 210 identifying whether the resource allocations for the first transceiver node 205-a and the second transceiver node 205-b are the same or different, e.g., based on the mode indicator, based on a one-bit indication, and the like. UE 210 may identify the resources of the second DCI message, e.g., based on at least one of the starting resource blocks, the techniques discussed above, and/or an explicit resource occupancy indication. UE 210 may receive a second DCI message in the indicated resources and decode the second DCI message to determine a second parameter set that is specific to the second transceiver node 205-b.

10 [0149] In some aspects, there may be a failure to decode the second DCI message. In this situation, UE 210 may know the transmission scheme for the downlink transmission (e.g., based on the mode indicator carried in the first DCI message). UE 210 may be aware that the downlink transmission is a multi-transceiver node transmission and that a portion of a codeword or a codeword will be lost. UE 210 may perform the codeword to layer mapping and the layer to port mapping, rate matching, and decoding based on the first DCI message that was successfully decoded and then provide a feedback signal that is configured based on the transmission scheme. As one example for case 1, UE 210 may generate an ACK/NACK signal for the first codeword and a NACK signal for the second codeword (or another dedicated signal to indicate the failure of receiving the second DCI message). As another example for case 2, UE 210 may generate an ACK/NACK for the first codeword if it is only associated with the first transceiver node 205-a and a NACK signal for the second codeword (or another dedicated signal to indicate the failure of receiving the second DCI message). In another example for case 3, UE 210 may generate an ACK/NACK signal for the codeword, e.g., due to missing one version of the codeword not necessarily impacting the ability of UE 210 to successfully decode the second version of the codeword. Generally, UE 210 may transmit the feedback signal (e.g., the ACK/NACK information) following a HARQ timing and downlink assignment index (DAI) configured in the first DCI message.

[0150] Specific examples of the describes techniques will now be discussed below. It is to be understood that these examples are not limiting, and the associated features may be implemented in other manners. Moreover, aspects of some or all of the different examples may be combined in some situations.

[0151] In a first example (example 1), the mode indicator may indicate that the transmission scheme is a transmit diversity scheme, e.g., a space and frequency block coding (SFBC) scheme. Aspects of example 1 may be associated with a first format (format 1) for the first DCI message where the same resource allocations are indicated for both transceiver nodes 205. Aspects of example 1 may also be associated with a case 3 transmission scheme where different versions of the same codeword are communicated by the transceiver nodes 205. Generally, the codewords may be mapped to layers according to the order: layer – frequency – time. For example, when two DMRS port groups are configured (e.g., one DMRS port group per transceiver node), the codeword may be mapped to layers according to:

$$\begin{aligned}x^{(0)}(i) &= d^{(0)}(2i) \\x^{(1)}(i) &= d^{(0)}(2i+1)\end{aligned}$$

[0152] As another example, where four DMRS port groups are configured (e.g., two DMRS port groups per transceiver node), the codeword may be mapped to layers according to:

$$\begin{aligned}x^{(0)}(i) &= d^{(0)}(4i) \\x^{(1)}(i) &= d^{(0)}(4i+1) \\x^{(2)}(i) &= d^{(0)}(4i+2) \\x^{(3)}(i) &= d^{(0)}(4i+3)\end{aligned}$$

[0153] The layers may then be mapped to DMRS port groups of the first transceiver node 205-a sequentially, e.g., in order of x . This mapping may depend on the number of configured DMRS ports. In the example where two DMRS ports are configured (e.g., one DMRS port group for each transceiver node 205, and each DMRS port group has one DMRS port), the layers may be mapped according to: $y^{(0)}(i) = x^{(0)}(i)$, $y^{(0)}(i+1) = x^{(1)}(i)$..., and so forth, for the first transceiver node 205-a. In the example where four DMRS ports are configured (e.g., two DMRS port groups for each transceiver node 205, and each DMRS port group has two DMRS ports), the layers may be mapped according to: $y^{(0)}(i) = x^{(0)}(i)$, $y^{(0)}(i+1) = x^{(1)}(i)$, $y^{(1)}(i+2) = x^{(2)}(i)$, $y^{(1)}(i+3) = x^{(3)}(i)$..., and so forth, for the first transceiver node 205-a. As one example, DMRS port 0 may be used for (i) and $(i+1)$ tones to carry layers 0 and 1, respectively.

[0154] In example 1, the layers may be mapped to DMRS port groups for the second transceiver node 205-b in a different manner. In the example where two DMRS ports are configured (e.g., one DMRS port group for each transceiver node 205, and each DMRS port group has one DMRS port), the layers may be mapped according to: $y^{(1)}(i) = x^{(1*)}(i)$,

5 $y^{(1)}(i+1) = x^{(0*)}(i)$..., and so forth, for the second transceiver node 205-b. In the example where four DMRS ports are configured (e.g., two DMRS port groups for each transceiver node 205, and each DMRS port group has two DMRS ports), the layers may be mapped according to: $y^{(2)}(i) = x^{(1*)}(i)$, $y^{(2)}(i+1) = -x^{(0*)}(i)$, $y^{(3)}(i+2) = x^{(3*)}(i)$,
 $y^{(3)}(i+3) = -x^{(2*)}(i)$..., and so forth, for the second transceiver node 205-b.

10 **[0155]** In a second example (example 2), the mode indicator may indicate that the transmission scheme is a transmit diversity scheme. Aspects of example 2 may be associated with a second format (format 2) for the first DCI message where different resource allocations are indicated for each transceiver node 205. Aspects of example 2 may also be associated with a case 3 transmission scheme where different versions of the same codeword
 15 are communicated by the transceiver nodes 205. For example, one codeword may be configured, with the codeword being replicated and the two transceiver nodes 205 using different redundancy versions (RVs) for the codeword. Mapping in example 2 may include codeword to port mapping. For example, a first version of the codeword having the first RV may be transmitted on resources of the first transceiver node 205-a according to the following
 20 mapping order: DMRS port – frequency – time. A second version of the codeword having the second RV may be transmitted on resources of the second transceiver node 205-b according to the following mapping order: DMRS port – frequency – time.

[0156] In a third example (example 3), the mode indicator may indicate that the transmission scheme is a transmit diversity scheme, e.g., a resource element level transceiver
 25 node 205 cycling. Aspects of example 3 may also be associated with a case 2 transmission scheme where different portions of the same codeword are communicated by the transceiver nodes 205, e.g., a first portion of the codeword communicated by the first transceiver node 205-a and a second portion of the codeword communicated by the second transceiver node 205-b. In some aspects, the first format (format 1) of the first DCI message may be used in
 30 example 3 where the same resource allocations are indicated for both transceiver nodes 205. For example, the DMRS port group of the first transceiver node 205-a may be active in even

tones, whereas the DMRS port group of the second transceiver node 205-b may be active in odd tones. Once configured, a first part of the codeword is transmitted using the resource allocation and DMRS port group of the first transceiver node 205-a and a second part of the codeword is transmitted using the resource allocation and DMRS port group of the second transceiver node 205-b.

[0157] In some aspects, two alternatives may be supported in example 3 for codeword to DMRS port group mapping for a rank 1 transmission. In a first alternative (Alt-1), codeword to DMRS port mapping may be configured according to: DMRS port (TRP1) – frequency – time - DMRS port (TRP2) – frequency – time. In a second alternative (Alt-2), codeword to DMRS port mapping may be configured according to: DMRS port (TRP1) - DMRS port (TRP2) – frequency - time. More particularly, codeword mapping according to the first and second alternatives may be configured according to:

Rank-1 Transmission (one DMRS port/TRP)		Codeword-to-Layer (Codeword may have M QAM Symbols)	Layer-to-DMRS Port
Alt-1	Alt-1.1	$x^0(i) = d^0(i), x^1(i) = d^0(i+1)$	$y^0(2i) = x^0(i), y^1(2i+1) = x^0(M/4+i)$ $y^0(2i+2) = x^1(i), y^1(2i+3) = x^1(M/4+i)$
	Alt-1.2	$x^0(i) = d^0(i), x^1(i) = d^0(M/2+i)$	$y^0(2i) = x^0(i), y^1(2i+1) = x^1(i)$ $y^0(2i+2) = x^0(i+1), y^1(2i+3) = x^1(i+1)$
Alt-2		$x^0(i) = d^0(i), x^1(i) = d^0(i+1)$	$y^0(2i) = x^0(i), y^1(2i+1) = x^1(i)$ $y^0(2i+2) = x^0(i+1), y^1(2i+3) = x^1(i+1)$

[0158] In example 3, the mode indicator in the first DCI message may indicate a transmit diversity scheme, e.g., resource element level transceiver node 205 cycling. In some aspects, two alternatives may be supported in example 3 for codeword to DMRS port mapping for a rank 2 transmission. In a first alternative (Alt-1), codeword to DMRS port mapping may be configured according to: DMRS port (TRP1) – frequency – time - DMRS port (TRP2) –

frequency – time. In a second alternative (Alt-2), codeword to DMRS port mapping may be configured according to: DMRS port (TRP1) - DMRS port (TRP2) – frequency - time. More particularly, codeword mapping according to the first and second alternatives for a rank 2 transmission may be configured according to:

Rank-2 Transmission (two DMRS ports/TRP)		Codeword-to-Layer (Codeword may have M QAM Symbols)	Layer-to-DMRS Port
Alt-1	Alt-1.1	$x^0(i) = d^0(i), x^1(i) = d^0(i+1)$ $x^2(i) = d^0(i+2), x^3(i) = d^0(i+3)$	$\begin{bmatrix} y^0(2i) \\ y^1(2i) \end{bmatrix} = \begin{bmatrix} x^0(i) \\ x^1(i) \end{bmatrix}, \begin{bmatrix} y^2(2i+1) \\ y^3(2i+1) \end{bmatrix} = \begin{bmatrix} x^0(M/4+i) \\ x^1(M/4+i) \end{bmatrix},$ $\begin{bmatrix} y^0(2i+2) \\ y^1(2i+2) \end{bmatrix} = \begin{bmatrix} x^2(i) \\ x^3(i) \end{bmatrix}, \begin{bmatrix} y^2(2i+3) \\ y^3(2i+3) \end{bmatrix} = \begin{bmatrix} x^2(M/4+i) \\ x^3(M/4+i) \end{bmatrix},$
	Alt-1.2	$x^0(i) = d^0(i), x^1(i) = d^0(i+1)$ $x^2(i) = d^0(M/2+i), x^3(i) = d^0(M/2+i+1)$	$\begin{bmatrix} y^0(2i) \\ y^1(2i) \end{bmatrix} = \begin{bmatrix} x^0(i) \\ x^1(i) \end{bmatrix}, \begin{bmatrix} y^2(2i+1) \\ y^3(2i+1) \end{bmatrix} = \begin{bmatrix} x^2(i) \\ x^3(i) \end{bmatrix},$ $\begin{bmatrix} y^0(2i+2) \\ y^1(2i+2) \end{bmatrix} = \begin{bmatrix} x^0(i+1) \\ x^1(i+1) \end{bmatrix}, \begin{bmatrix} y^2(2i+3) \\ y^3(2i+3) \end{bmatrix} = \begin{bmatrix} x^2(i+1) \\ x^3(i+1) \end{bmatrix},$
Alt-2		$x^0(i) = d^0(i), x^1(i) = d^0(i+1)$ $x^2(i) = d^0(i+2), x^3(i) = d^0(i+3)$	$\begin{bmatrix} y^0(2i) \\ y^1(2i) \end{bmatrix} = \begin{bmatrix} x^0(i) \\ x^1(i) \end{bmatrix}, \begin{bmatrix} y^2(2i+1) \\ y^3(2i+1) \end{bmatrix} = \begin{bmatrix} x^2(i) \\ x^3(i) \end{bmatrix},$ $\begin{bmatrix} y^0(2i+2) \\ y^1(2i+2) \end{bmatrix} = \begin{bmatrix} x^0(i+1) \\ x^1(i+1) \end{bmatrix}, \begin{bmatrix} y^2(2i+3) \\ y^3(2i+3) \end{bmatrix} = \begin{bmatrix} x^2(i+1) \\ x^3(i+1) \end{bmatrix},$

5 [0159] In some aspects of example 3, the mode indicator in the first DCI message may indicate a transmit diversity scheme, e.g., with resource element level TRP cycling for a case 2 transmission scheme. For example, precoder cycling within each TRP (e.g., a rank 2 case) may be supported. When the DMRS port groups of TRP1 are used in even tones (e.g., 2i, 2i+2, 2i+4, etc.), for tones 2i, 2i+4, 2i+8, etc., the layer-to-DMRS port mapping may be

10 based on $U_0 = \begin{bmatrix} 1,1 \\ 1,-1 \end{bmatrix}$ and for tones 2i, 2i+2, 2i+6, etc., the layer-to-DMRS port mapping may

be based on $U_n = \begin{bmatrix} 1, j \\ 1, -j \end{bmatrix}$. When the DMRS port groups of TRP1 are used in odd tones (e.g., $2i+1, 2i+3, 2i+5$, etc.), for tones $2i+1, 2i+5, 2i+9$, etc., the layer-to-DMRS port mapping may be based on $U_n = \begin{bmatrix} 1, 1 \\ 1, -1 \end{bmatrix}$ and for tones $2i+3, 2i+7, 2i+9$, etc., the layer-to-DMRS port mapping may be based on $U_o = \begin{bmatrix} 1, j \\ 1, -j \end{bmatrix}$. In this case, the layer-to-DMRS port mapping may

5 be configured according to:

Rank-2 Transmission (two DMRS ports/TRP)		Layer-to-DMRS Port
Alt-1	Alt-1.1	$\begin{bmatrix} y^0(2i) \\ y^1(2i) \end{bmatrix} = U_0 \begin{bmatrix} x^0(i) \\ x^1(i) \end{bmatrix}, \begin{bmatrix} y^2(2i+1) \\ y^3(2i+1) \end{bmatrix} = U_0 \begin{bmatrix} x^0(M/4+i) \\ x^1(M/4+i) \end{bmatrix},$ $\begin{bmatrix} y^0(2i+2) \\ y^1(2i+2) \end{bmatrix} = U_1 \begin{bmatrix} x^2(i) \\ x^3(i) \end{bmatrix}, \begin{bmatrix} y^2(2i+3) \\ y^3(2i+3) \end{bmatrix} = U_1 \begin{bmatrix} x^2(M/4+i) \\ x^3(M/4+i) \end{bmatrix},$
	Alt-1.2	$\begin{bmatrix} y^0(2i) \\ y^1(2i) \end{bmatrix} = U_0 \begin{bmatrix} x^0(i) \\ x^1(i) \end{bmatrix}, \begin{bmatrix} y^2(2i+1) \\ y^3(2i+1) \end{bmatrix} = U_0 \begin{bmatrix} x^2(i) \\ x^3(i) \end{bmatrix},$ $\begin{bmatrix} y^0(2i+2) \\ y^1(2i+2) \end{bmatrix} = U_1 \begin{bmatrix} x^0(i+1) \\ x^1(i+1) \end{bmatrix}, \begin{bmatrix} y^2(2i+3) \\ y^3(2i+3) \end{bmatrix} = U_1 \begin{bmatrix} x^2(i+1) \\ x^3(i+1) \end{bmatrix},$
Alt-2		$\begin{bmatrix} y^0(2i) \\ y^1(2i) \end{bmatrix} = U_0 \begin{bmatrix} x^0(i) \\ x^1(i) \end{bmatrix}, \begin{bmatrix} y^2(2i+1) \\ y^3(2i+1) \end{bmatrix} = U_0 \begin{bmatrix} x^2(i) \\ x^3(i) \end{bmatrix},$ $\begin{bmatrix} y^0(2i+2) \\ y^1(2i+2) \end{bmatrix} = U_1 \begin{bmatrix} x^0(i+1) \\ x^1(i+1) \end{bmatrix}, \begin{bmatrix} y^2(2i+3) \\ y^3(2i+3) \end{bmatrix} = U_1 \begin{bmatrix} x^2(i+1) \\ x^3(i+1) \end{bmatrix},$

[0160] In a fourth example (example 4), the mode indicator may indicate that the transmission scheme is a transmit diversity scheme, e.g., a sub-band/resource block level transceiver node 205 cycling. Aspects of example 4 may also be associated with a case 2 transmission scheme where different portions of the same codeword are communicated by the transceiver nodes 205, e.g., a first portion of the codeword communicated by the first transceiver node 205-a and a second portion of the codeword communicated by the second transceiver node 205-b. In some aspects, the second format (format 2) of the first DCI

message may be used in example 4 where different resource allocations are indicated for the transceiver nodes 205. For example, the DMRS port group of the first transceiver node 205-a may be active in odd resource blocks, whereas the DMRS port group of the second transceiver node 205-b may be active in even resource blocks. Once configured, a first part of the codeword is transmitted using the resource allocation and DMRS port group of the first transceiver node 205-a and a second part of the codeword is transmitted using the resource allocation and DMRS port group of the second transceiver node 205-b.

[0161] In some aspects, two alternatives may be supported in example 4 for codeword to DMRS port mapping for a rank 1 transmission. In a first alternative (Alt-1), codeword to DMRS port mapping may be configured according to: DMRS port (TRP1) – frequency (TRP1) – time - DMRS port (TRP2) – frequency (TRP2) – time. In a second alternative (Alt-2), codeword to DMRS port mapping may be configured according to: DMRS port (TRP1) – frequency (TRP1) – DMRS port (TRP2) – frequency (TRP2) - time. More particularly, codeword mapping according to the first and second alternatives may be configured according to:

Rank-1 Transmission (one DMRS port/TRP)		Codeword-to-Layer (Codeword has M QAM Symbols)	Layer-to-DMRS Port (N is frequency offset of TRP2 relative to TRP1; N' is the number of Resources for TRP1 in the assigned slot)
Alt-1	Alt-1.1	$x^0(i) = d^0(i), x^1(i) = d^0(i+1)$	$y^0(2i) = x^0(i), y^1(2i+N) = x^0(N'+i)$ $y^0(2i+1) = x^1(i), y^1(2i+N+1) = x^1(N'+i)$
	Alt-1.2	$x^0(i) = d^0(i), x^1(i) = d^0(N'+i)$	$y^0(2i) = x^0(i), y^1(2i+N) = x^1(i)$ $y^0(2i+1) = x^0(i+1), y^1(2i+N+1) = x^1(i+1)$
Alt-2		$z^0(i) = d^0(i)$ wherein $z^0(i)$ is 1) obtained by the aggregated resource allocations of TRP1 and TRP2, 2) index I is order based on the order frequency to time, and 3) in the resource allocation of TRP1, $z^0(i) = y^0(i)$ while in the resource allocation of TRP2, $z^0(i) = y^1(i)$	

[0162] In example 4, the mode indicator in the first DCI message may indicate a transmit diversity scheme, e.g., sub-band/resource block level transceiver node 205 cycling. In some aspects, two alternatives may be supported in example 4 for codeword to DMRS port mapping for a rank 2 transmission. Codeword mapping according to the first and second alternatives for a rank 2 transmission where four DMRS port groups are configured may be configured according to:

Rank-2 Transmission (two DMRS ports/TRP)		Codeword-to-Layer (Codeword may have M QAM Symbols and $N' < M$)	Layer-to-DMRS Port (N is frequency offset of TRP2 relative to TRP1; N' is the number of resources for TRP1 in the assigned slot)
Alt-1	Alt-1.1	$x^0(i) = d^0(i), x^1(i) = d^0(i+1)$ $x^2(i) = d^0(i+2), x^3(i) = d^0(i+3)$	$\begin{bmatrix} y^0(2i) \\ y^1(2i) \end{bmatrix} = \begin{bmatrix} x^0(i) \\ x^1(i) \end{bmatrix}, \begin{bmatrix} y^2(2i+N) \\ y^3(2i+N) \end{bmatrix} = \begin{bmatrix} x^0(N'+i) \\ x^1(N'+i) \end{bmatrix}$ $\begin{bmatrix} y^0(2i+1) \\ y^1(2i+1) \end{bmatrix} = \begin{bmatrix} x^2(i) \\ x^3(i) \end{bmatrix}, \begin{bmatrix} y^2(2i+N+1) \\ y^3(2i+N+1) \end{bmatrix} = \begin{bmatrix} x^2(N'+i) \\ x^3(N'+i) \end{bmatrix}$
	Alt-1.2	$x^0(i) = d^0(i), x^1(i) = d^0(i+1)$ $x^2(i) = d^0(2N'+i), x^3(i) = d^0(2N'+i+1)$	$\begin{bmatrix} y^0(2i) \\ y^1(2i) \end{bmatrix} = \begin{bmatrix} x^0(i) \\ x^1(i) \end{bmatrix}, \begin{bmatrix} y^2(2i+N) \\ y^3(2i+N) \end{bmatrix} = \begin{bmatrix} x^2(i) \\ x^3(i) \end{bmatrix}$ $\begin{bmatrix} y^0(2i+1) \\ y^1(2i+1) \end{bmatrix} = \begin{bmatrix} x^0(i+1) \\ x^1(i+1) \end{bmatrix}, \begin{bmatrix} y^2(2i+N+1) \\ y^3(2i+N+1) \end{bmatrix} = \begin{bmatrix} x^2(i+1) \\ x^3(i+1) \end{bmatrix}$
Alt-2		$\begin{bmatrix} z^0(i) \\ z^1(i) \end{bmatrix} = \begin{bmatrix} d^0(i) \\ d^1(i+1) \end{bmatrix}, \text{ where } \begin{bmatrix} z^0(i) \\ z^1(i) \end{bmatrix} \text{ is 1) obtained by the aggregated resources of the resource allocations for TRP1 and TRP2, 2) index } i \text{ is order based on the order frequency to time, and 3) in the resource allocation of TRP1,}$ $\begin{bmatrix} z^0(i) \\ z^1(i) \end{bmatrix} = \begin{bmatrix} y^0(i) \\ y^1(i) \end{bmatrix}, \text{ while in the resource allocation of TRP2 } \begin{bmatrix} z^0(i) \\ z^1(i) \end{bmatrix} = \begin{bmatrix} y^2(i) \\ y^3(i) \end{bmatrix}$	

[0163] In some aspects of example 4, the mode indicator in the first DCI message may indicate a transmit diversity scheme, e.g., with sub-band/resource block level TRP cycling for a case 2 transmission scheme. For example, precoder cycling within each TRP (e.g., a rank 2

case) may be supported. In the resources for TRP1 and for even tones, the layer-to-port mapping may be based on $U_0 = \begin{bmatrix} 1, 1 \\ 1, -1 \end{bmatrix}$, and for odd tones the layer-to-port mapping may be based on $U_n = \begin{bmatrix} 1, j \\ 1, -j \end{bmatrix}$. In the resources for TRP2 and for even tones, the layer-to-port mapping may be based on $U_0 = \begin{bmatrix} 1, 1 \\ 1, -1 \end{bmatrix}$, and for odd tones the layer-to-port mapping may be based on $U_n = \begin{bmatrix} 1, j \\ 1, -j \end{bmatrix}$.

[0164] In a fifth example (example 5), the mode indicator may indicate that the transmission scheme is a spatial multiplexing scheme. Aspects of example 5 may be associated with a first format (format 1) for the first DCI message where the same resource allocations are indicated for both transceiver nodes 205. Aspects of example 1 may also be associated with a case 1 transmission scheme where different codewords are communicated by each transceiver nodes 205. For example, a first codeword (CW1) may be transmitted using the DMRS port groups of TRP1 and a second codeword (CW2) may be transmitted using the DMRS port groups of TRP2. The order for the mapping may be: layer (CW1, TRP1) – frequency – time – layer (CW2, TRP2) – frequency – time. For example and when two DMRS port groups are configured, one for each TRP, and each DMRS port group has two DMRS ports, the codeword may be mapped to layers according to:

$x^0(i) = d^0(i), x^1(i) = d^0(i+1)$ and $x^2(i) = d^1(i), x^3(i) = d^1(i+1)$. The layer-to-port mapping may include a one-to-one mapping according to:

$y^0(i) = x^0(i), y^1(i) = x^1(i), y^2(i) = x^2(i), y^3(i) = x^3(i)$, wherein $y^p(i)$ refers to port P on

subcarrier 1, and where index i is ordered following: frequency – time.

[0165] In a sixth example (example 6), the mode indicator may indicate that the transmission scheme is a spatial multiplexing scheme. Aspects of example 6 may be associated with a second format (format 2) for the first DCI message where different resource allocations are indicated for transceiver nodes 205. Aspects of example 6 may also be associated with a case 1 transmission scheme where different codewords are communicated by each transceiver nodes 205. For example, CW1 may be transmitted using the DMRS port groups of TRP1 on a first resource allocation and CW2 may be transmitted using the DMRS

port groups of TRP2 on a second resource allocation. Each codeword may be mapped to DMRS port groups associated with the corresponding TRP. The order for the mapping may be: layer (CW1, TRP1) – frequency (TRP1) – time (TRP1) – layer (CW2, TRP2) – frequency (TRP2) – time (TRP2). For example and when two DMRS port groups are configured, one for each TRP, and each DMRS port group has one DMRS port, the codeword may be mapped to layers according to: $x^0(i) = d^0(i)$, $x^1(i) = d^0(i+1)$ and $x^2(i) = d^1(i)$, $x^3(i) = d^1(i+1)$. The layer-to-port mapping may include a one-to-one mapping according to:

$y^0(i) = x^0(i)$, $y^1(i) = x^1(i)$, $y^2(i+N) = x^2(i)$, $y^3(i+N) = x^3(i)$, wherein $y^p(i)$ refers to port P on subcarrier 1, and where index i is ordered following: frequency – time within each resource allocation. In some aspects, N may denote a sub-band offset of the resource allocation for TRP2 relative to TRP1. In some aspects, DMRS port 0 and 1 may be active on the first resource allocation for TRP1 whereas DMRS ports 2 and 3 may be active on the second resource allocation for TRP2.

[0166] In a seventh example (example 7), the mode indicator may indicate that the transmission scheme is a spatial multiplexing scheme. Aspects of example 7 may also be associated with a case 2 transmission scheme where different portions or parts of the same codeword are communicated by the transceiver nodes 205, e.g., a first portion of the codeword communicated using the DMRS port groups of the first transceiver node 205-a and a second portion of the codeword communicated using the DMRS port groups of the second transceiver node 205-b. In some aspects, the first format (format 1) of the first DCI message may be used in example 7 where the same resource allocations are indicated for both transceiver nodes 205.

[0167] In some aspects, two alternatives may be supported in example 7 for codeword to DMRS port mapping. In a first alternative (Alt-1), codeword to DMRS port mapping may be configured according to: DMRS port (TRP1) – frequency – time - DMRS port (TRP2) – frequency – time. In a second alternative (Alt-2), codeword to DMRS port mapping may be configured according to: DMRS port (TRP1) - DMRS port (TRP2) – frequency - time. More particularly, codeword mapping according to the first and second alternatives may be configured according to:

Two DMRS ports/TRP	Codeword-to-Layer	Layer-to-DMRS Port
--------------------	-------------------	--------------------

	(Codeword may have M QAM Symbols)	
Alt-1	$\begin{bmatrix} x^0(i) \\ x^1(i) \\ x^2(i) \\ x^3(i) \end{bmatrix} = \begin{bmatrix} d^0(i) \\ d^0(i+1) \\ d^0(M/2+2) \\ d^0(M/2+i+2) \end{bmatrix}$	$\begin{bmatrix} y^0(i) \\ y^1(i) \\ y^2(i) \\ y^3(i) \end{bmatrix} = \begin{bmatrix} x^0(i) \\ x^1(i) \\ x^2(i) \\ x^3(i) \end{bmatrix}$
Alt-2	$\begin{bmatrix} x^0(i) \\ x^1(i) \\ x^2(i) \\ x^3(i) \end{bmatrix} = \begin{bmatrix} d^0(i) \\ d^0(i+1) \\ d^0(i+2) \\ d^0(i+3) \end{bmatrix}$	$\begin{bmatrix} y^0(i) \\ y^1(i) \\ y^2(i) \\ y^3(i) \end{bmatrix} = \begin{bmatrix} x^0(i) \\ x^1(i) \\ x^2(i) \\ x^3(i) \end{bmatrix}$

[0168] In an eighth example (example 8), the mode indicator may indicate that the transmission scheme is a spatial multiplexing scheme. Aspects of example 8 may also be associated with a case 2 transmission scheme where different portions or parts of the same codeword are communicated by the transceiver nodes 205, e.g., a first portion of the codeword communicated using the DMRS port groups of the first transceiver node 205-a and a second portion of the codeword communicated using the DMRS port groups of the second transceiver node 205-b. In some aspects, the second format (format 2) of the first DCI message may be used in example 8 where different resource allocations indicated for the transceiver nodes 205.

10 **[0169]** In some aspects, two alternatives may be supported in example 8 for codeword to DMRS port mapping. In a first alternative (Alt-1), codeword to DMRS port mapping may be configured according to: DMRS port (TRP1) – frequency (TRP1) – time - DMRS port (TRP2) – frequency (TRP2) – time. In a second alternative (Alt-2), codeword to DMRS port mapping may be configured according to: DMRS port (TRP1) – frequency (TRP1) – DMRS port (TRP2) – frequency (TRP2) - time. More particularly, codeword mapping according to the first and second alternatives may be configured according to:

Two DMRS ports/TRP	Codeword-to-Layer (Codeword may have M QAM	Layer-to-DMRS Port
--------------------	---	--------------------

	Symbols)	
Alt-1	$\begin{bmatrix} x^0(i) \\ x^1(i) \\ x^2(i) \\ x^3(i) \end{bmatrix} = \begin{bmatrix} d^0(i) \\ d^0(i+1) \\ d^0(2N^1+i) \\ d^0(2N^1+i+1) \end{bmatrix}$	$\begin{bmatrix} y^0(i) \\ y^1(i) \\ y^2(i+N) \\ y^3(i+N) \end{bmatrix} = \begin{bmatrix} x^0(i) \\ x^1(i) \\ x^2(i) \\ x^3(i) \end{bmatrix}$
Alt-2	$\begin{bmatrix} y^0(i) \\ y^1(i) \end{bmatrix} = \begin{bmatrix} x^0(i) \\ x^1(i) \end{bmatrix} = \begin{bmatrix} d^0(i) \\ d^1(i+1) \end{bmatrix}$, where index i is obtained by aggregating the first resource allocation for TRP1 and the second resource allocation for TRP2 following the order: frequency to time; in the first resource allocation, $y^0(i)$ and $y^1(i)$ are the port of TRP1; in the second resource allocation, $y^0(i)$ and $y^1(i)$ are the port of TRP2.	

[0170] In a ninth example (example 9), the mode indicator may indicate that the transmission scheme is a spatial multiplexing scheme. Aspects of example 9 may also be associated with a case 2 transmission scheme where different portions or parts of the same codeword are communicated by the transceiver nodes 205, as well as a second codeword (CW2) being communicated by the second transceiver node 205-b That is, a first portion of CW1 communicated using the DMRS port groups of the first transceiver node 205-a, a second portion of CW1 may be communicated using a first set of DMRS port groups of the second transceiver node 205-b, and CW2 may be communicated using a second set of DMRS port groups of the second transceiver node 205-b. In some aspects, the first format (format 1) of the first DCI message may be used in example 9 where the same resource allocations are indicated for the transceiver nodes 205.

[0171] In some aspects, UE 210 may determine the first and second set of DMRS ports of TRP2. For example, UE 210 may aggregate the DMRS port groups according to: DMRS port (TRP1) – DMRS port (TRP2). UE 210 may then determine the association between the aggregated ports and the codewords, such as in a single TRP case, e.g., for layers/DMRS ports 1-4 - one codeword; for layers/DMRS ports > four - two codewords. More particularly, according to (2,3), (3,3), (3,4), (4,3), wherein the first number indicates the layer for CW1 and the second number indicates the layer for CW2.

[0172] In some aspects, two alternatives may be supported in example 9 for codeword to DMRS port mapping for CW1. In a first alternative (Alt-1), codeword to DMRS port mapping may be configured according to: DMRS port (TRP1) – frequency – time - DMRS port (TRP2) – frequency – time. In a second alternative (Alt-2), codeword to DMRS port mapping may be configured according to: DMRS port (TRP1)– DMRS port (TRP2) – frequency - time. More particularly, codeword mapping according to the first and second alternatives may be configured according to:

TRP1 – 2 DMRS Ports TRP2 – 4 DMRS Ports	Codeword-to-Layer (Codeword has M QAM Symbols)	Layer-to-DMRS Port
Alt-1	$\begin{bmatrix} x^0(i) \\ x^1(i) \\ x^2(i) \\ x^3(i) \\ x^4(i) \\ x^5(i) \end{bmatrix} = \begin{bmatrix} d^0(i) \\ d^0(i+1) \\ d^0(2M/3+i) \\ d^1(i) \\ d^1(i+1) \\ d^1(i+2) \end{bmatrix}$	$\begin{bmatrix} y^0(i) \\ y^1(i) \\ y^2(i) \\ y^3(i) \\ y^4(i) \\ y^5(i) \end{bmatrix} = \begin{bmatrix} x^0(i) \\ x^1(i) \\ x^2(i) \\ x^3(i) \\ x^4(i) \\ x^5(i) \end{bmatrix}$
Alt-2	$\begin{bmatrix} x^0(i) \\ x^1(i) \\ x^2(i) \\ x^3(i) \\ x^4(i) \\ x^5(i) \end{bmatrix} = \begin{bmatrix} d^0(i) \\ d^0(i+1) \\ d^0(i+2) \\ d^1(i) \\ d^1(i+1) \\ d^1(i+2) \end{bmatrix}$	$\begin{bmatrix} y^0(i) \\ y^1(i) \\ y^2(i) \\ y^3(i) \\ y^4(i) \\ y^5(i) \end{bmatrix} = \begin{bmatrix} x^0(i) \\ x^1(i) \\ x^2(i) \\ x^3(i) \\ x^4(i) \\ x^5(i) \end{bmatrix}$

[0173] For CW2 mapping in example 9, the DMRS port mapping may be configured according to: DMRS port – frequency – time.

10 [0174] Based on the information determined above (e.g., the mode indicator and one or more of the parameter sets indicated in the first DCI message and/or second DCI message), UE 210 may receive the downlink transmissions from the first transceiver node 205-a and the second transceiver node 205-b according to the determined transmission scheme, QCL information, rate matching configuration, resource allocation, and the like. UE 210 may
 15 transmit feedback information based on its success or failure to decode the DCI message(s) and/or downlink transmission from each transceiver node 205.

[0175] FIG. 3 illustrates an example of a DCI configuration 300 that supports single and multi-stage DCI design for multiple transceiver nodes in accordance with aspects of the present disclosure. In some examples, DCI configuration 300 may implement aspects of wireless communication systems 100/200. Aspects of DCI configuration 300 may be implemented by a base station and/or UE, which may be examples of the corresponding devices described herein. Generally, DCI configuration 300 illustrates a format 1 DCI configuration, which may be used in a single-stage DCI design.

[0176] As discussed above, the UE may receive a DCI message that carries, or otherwise conveys, an indication of a mode indicator, parameter sets that are common to each TRP participating in the downlink transmission, and one or more parameter sets that are specific to particular TRPs participating in the downlink transmission. DCI configuration 300 illustrates one example of how the DCI message can be configured for transmission to the UE, and used by the UE to determine the transmission scheme and/or associated communication parameters to use during the downlink transmission.

[0177] DCI configuration 300 may include a mode indicator field 305, a codeword information field 310, a HARQ process number field 315, a HARQ timing field 320, a downlink assignment index (DAI) field 325, a resource allocation field 330, a DMRS1 configuration information field 335, and a DMRS2 configuration information field 340. Broadly, the mode indicator field 305 may explicitly or implicitly indicate a transmission scheme being used for the downlink transmission. For example, the mode indicator field 305 may include one or more bits or fields that identifies a transmission scheme, identifies a number or index associated with a transmission scheme, and the like. Implicitly, the transmission scheme may be indicated based at least in part on a CRC scrambling sequence associated with the DCI message. Generally, the transmission scheme may indicate or otherwise be associated with a link or association between a codeword and a DMRS port group for one or more TRPs participating in the downlink transmission.

[0178] Codeword information field 310 may generally convey an indication of one or codeword communication parameters being used for the downlink transmission. In some aspects, codeword information field 310 may be considered a part of a common parameter set that is associated with each TRP participating in the downlink transmission. Generally, codeword information field 310 may carry or otherwise provide an indication of an MCS, a

new data indicator (NDI), a redundancy version (RV), and the like, for each TRP. In some examples, the codeword information field 310 may carry or otherwise provide an indication of a separate MCS, NDI, RV, and the like, for each TRP, e.g., when the configured maximum number of codewords scheduled by the DCI is two.

5 [0179] The HARQ process number field 315 generally carries or otherwise conveys an indication of a number or identifier associated with each HARQ process configured by the DCI. Moreover, the HARQ timing field 320 generally carries or otherwise conveys an indication of a timing parameter for each HARQ process, e.g., an indication of timing for transmission of a feedback signal.

10 [0180] Broadly, the DAI field 325 may carry or otherwise convey an indication of a number or index identifying all of the downlink data being communicated during the downlink transmission that has been bundled into one HARQ ACK/NACK transmission. The resource allocation field 330 may carry or otherwise convey an indication of time and/or frequency resources that are allocated to the one or more TRPs participating in the downlink
15 transmission. Again, in the format 1 DCI configuration 300, the same resources are allocated in the resource allocation field 330 for both (or all) TRPs participating in the downlink transmission.

[0181] The DMRS1 configuration information field 335 generally carries or otherwise indicates a parameter set that are specific to a first DMRS port group. In some aspects, the
20 first DMRS port group may be associated with a particular TRP, such as TRP1, for the downlink transmission. Similarly, the DMRS2 configuration information field 340 generally carries or otherwise indicates a parameter set that are specific to a second DMRS port group. In some aspects, the second DMRS port group may be associated with a particular TRP, such as TRP2, for the downlink transmission. For example, each DMRS port group specific
25 configuration information field 335 and 340 may provide an indication of a DMRS configuration (e.g., the DMRS port configuration information), QCL information, rate matching configuration, and the like, for the corresponding TRP to use during the downlink transmission.

[0182] It is to be understood that different configurations may be implemented with
30 respect to the DMRS configuration information fields 335 and 340. In some aspects, this may include the indication of the DMRS configuration being moved to the portion of the DCI

message that indicates the common parameter set. For example, the DMRS configuration information illustrated in DCI configuration 300 as being provided in the DMRS1

configuration information field 335 and DMRS2 configuration information field 340 may, instead, be indicated in a separate information field (not shown). As one non-limiting

5 example, the UE may be preconfigured with available sets of DMRS port groups, with each

DMRS port group including one or more DMRS ports. This may be accomplished using higher layer signaling (e.g., RRC and/or MAC CE signaling). In this example, the DMRS

configuration may include a bit, a bitmap, or other field that indicates which DMRS port group(s) is/are activated for the downlink transmission from the respective TRP. In another

10 example, the UE may not be preconfigured with the available sets of DMRS port groups. In

this example, the DMRS configuration may identify which DMRS port groups are being

activated for the downlink transmission. The DMRS configuration may further include one or more configuration parameters for the DMRS port group(s) used for the downlink

transmission.

15 **[0183]** Generally, the codeword information field 310, the HARQ process number field 315, the HARQ timing field 320, the DAI field 325, and/or the resource allocation field 330 may be considered a common parameter set that is applicable to each TRP participating in the

downlink transmission. Generally, each of the DMRS1 configuration information field 335

and DMRS2 configuration information field 340 may be considered one or more DMRS port

20 group specific parameter set. As discussed, the DMRS information may be indicated in the

DMRS1/2 configuration information fields 335/340 (as is indicated in FIG. 3), or may be

indicated separately in a stand-alone field (e.g., as part of the common parameter set).

[0184] Accordingly, the UE may receive a DCI message configured according to DCI

configuration 300 and use the mode indicator to determine the transmission scheme for the

25 downlink transmission and the common parameter set and one or more DMRS port group

specific parameter sets to identify the QCL information, the rate matching configuration, the

resource allocation, and the like, for each DMRS port group. The UE may receive the

downlink transmission from TRP1 and TRP2 according to the transmission scheme and other

parameters identified from DCI configuration 300.

30 **[0185]** FIG. 4 illustrates an example of a DCI configuration 400 that supports single and

multi-stage DCI design for multiple transceiver nodes in accordance with aspects of the

present disclosure. In some examples, DCI configuration 400 may implement aspects of wireless communication systems 100/200. Aspects of DCI configuration 400 may be implemented by a base station and/or UE, which may be examples of the corresponding devices described herein. Generally, DCI configuration 400 illustrates a format 2 (option 1) DCI configuration, which may be used in a single stage DCI design.

[0186] As discussed above, the UE may receive a DCI message that carries or otherwise conveys an indication of a mode indicator, parameter sets that are common to each TRP participating in the downlink transmission, and one or more parameter sets that are specific to a particular TRP participating in the downlink transmission. DCI configuration 400 illustrates one example of how the DCI message can be configured for transmission to the UE, and used by the UE to determine the transmission scheme and/or associated communication parameters use during the downlink transmission.

[0187] DCI configuration 400 may include a mode indicator field 405, a codeword information field 410, a HARQ process number field 415, a HARQ timing field 420, a DAI field 425, a DMRS1 configuration information field 430, and a DMRS2 configuration information field 435. Broadly, the mode indicator field 405 may explicitly or implicitly indicate a transmission scheme being used for the downlink transmission. For example, the mode indicator field 405 may include one or more bits or fields that identifies a transmission scheme, identifies a number or index associated with a transmission scheme, and the like. Implicitly, the transmission scheme may be indicated based at least in part on a CRC scrambling sequence associated with the DCI configuration 400. Generally, the transmission scheme may indicate otherwise be associated with a link or association between a codeword and a DMRS port group for one or more TRPs participating in the downlink transmission.

[0188] Codeword information field 410 may generally convey an indication of one or more codeword communication parameters being used for the downlink transmission. In some aspects, codeword information field 410 may be considered a part of a common parameter set that is associated with each TRP participating in the downlink transmission. Generally, codeword information field 410 may carry or otherwise provide an indication of a MCS, a NDI, a RV, and the like, for each TRP. In some examples, the codeword information field 410 may carry or otherwise provide an indication of a separate MCS, NDI, RV, and the like,

for each TRP, e.g., when the configured maximum number of codewords scheduled by the DCI is two.

[0189] The HARQ process number field 415 generally carries or otherwise conveys an indication of a number or identifier associated with each HARQ process configured by the DCI. Moreover, the HARQ timing field 420 generally carries or otherwise conveys an indication of a timing parameter for each HARQ process, e.g., an indication of timing for transmission of a feedback signal.

[0190] Broadly, the DAI field 425 may carry or otherwise convey an indication of a number or index identifying all of the downlink data being communicated during the downlink transmission that has been bundled into one HARQ ACK/NACK transmission.

[0191] The DMRS1 configuration information field 430 generally carries or otherwise indicates a parameter set that are specific to a first DMRS port group. In some aspects, the first DMRS port group may be associated with a particular TRP, such as TRP1, for the downlink transmission. Similarly, the DMRS2 configuration information field 435 generally carries or otherwise indicate a parameter set that are specific to a second DMRS port group. In some aspects, the second DMRS port group may be associated with a particular TRP, such as TRP2, for the downlink transmission. For example, each DMRS specific configuration information field 430 and 435 may provide an indication of a DMRS configuration (e.g., the DMRS port configuration information), QCL information, rate matching configuration, and the like, for the corresponding TRP to use during the downlink transmission. One difference between the DCI configuration 300 and DCI configuration 400 is that the resource allocation for each TRP is provided in the DMRS port group specific parameter set. Thus, each DMRS specific configuration information field 430 and 435 may also carry or otherwise convey an indication of the time and/or frequency resources that are allocated to the corresponding TRP. Again, in the format 2 (option 1) DCI configuration 400, different resources may be allocated for each TRPs participating in the downlink transmission.

[0192] It is to be understood that different configurations may be implemented with respect to the DMRS configuration information fields 430 and 435. In some aspects, this may include the indication of the DMRS configuration being moved to the portion of the DCI message that indicates the common parameter set. For example, the DMRS configuration information illustrated in DCI configuration 400 as being provided in the DMRS1

configuration information field 430 and DMRS2 configuration information field 435 may, instead, be indicated in a separate information field (not shown). As one non-limiting example, the UE may be preconfigured with available sets of DMRS port groups, with each DMRS port group including one or more DMRS ports. In this example, the DMRS
5 configuration may include a bit, a bitmap, or other field that indicates which DMRS port group(s) is/are activated for the downlink transmission from the respective TRP. In another example, the UE may not be preconfigured with the available sets of DMRS port groups. In this example, the DMRS configuration may identify which DMRS port groups are being activated for the downlink transmission. The DMRS configuration may further include one or
10 more configuration parameters for the DMRS port group(s) used for the downlink transmission.

[0193] Generally, the codeword information field 410, the HARQ process number field 415, the HARQ timing field 420, and/or the DAI field 425 may be considered a common parameter set that is applicable to each TRP participating in the downlink transmission.
15 Generally, each of the DMRS1 configuration information field 430 and DMRS2 configuration information field 435 may be considered a DMRS port group specific parameter set.

[0194] Accordingly, the UE may receive a DCI message configured according to DCI configuration 400 and use the mode indicator to determine the transmission scheme for the
20 downlink transmission and the common parameter set and one or more DMRS port group specific parameter sets to identify the QCL information, the rate matching configuration, the resource allocation, and the like, for each DMRS port group. The UE may receive the downlink transmission from TRP1 and TRP2 according to the transmission scheme and other parameters identified from DCI configuration 400.

[0195] **FIG. 5** illustrates an example of a DCI configuration 500 that supports single and multi-stage DCI design for multiple transceiver nodes in accordance with aspects of the present disclosure. In some examples, DCI configuration 500 may implement aspects of wireless communication systems 100/200. Aspects of DCI configuration 500 may be implemented by a base station and/or UE, which may be examples of the corresponding
25 devices described herein. Generally, DCI configuration 500 illustrates a format 2 (option 2) DCI configuration, which may be used in a single stage DCI design.
30

[0196] As discussed above, the UE may receive a DCI message that carries or otherwise conveys an indication of a mode indicator, parameter sets that are common to each TRP participating in the downlink transmission, and one or more parameter sets that are specific to a particular TRP participating in the downlink transmission. DCI configuration 500 illustrates one example of how the DCI message can be configured for transmission to the UE, and used by the UE to determine the transmission scheme and/or associated communication parameters use during the downlink transmission.

[0197] DCI configuration 500 may include a mode indicator field 505, a codeword information field 510, a HARQ process number field 515, a HARQ timing field 520, a DAI field 525, a DMRS port configuration field 530, a DMRS1 configuration information field 535, and a DMRS2 configuration information field 540. Broadly, the mode indicator field 505 may explicitly or implicitly indicate a transmission scheme being used for the downlink transmission. For example, the mode indicator field 505 may include one or more bits or fields that identifies a transmission scheme, identifies a number or index associated with a transmission scheme, and the like. Implicitly, the transmission scheme may be indicated based at least in part on a CRC scrambling sequence associated with the DCI configuration 500. Generally, the transmission scheme may indicate otherwise be associated with a link or association between a codeword and a DMRS port group for one or more TRPs participating in the downlink transmission.

[0198] Codeword information field 510 may generally convey an indication of one or codeword communication parameters being used for the downlink transmission. In some aspects, codeword information field 510 may be considered a part of a common parameter set that is associated with each TRP participating in the downlink transmission. Generally, codeword information field 510 may carry or otherwise provide an indication of a MCS, a NDI, a RV, and the like, for each TRP. In some examples, the codeword information field 510 may carry or otherwise provide an indication of a separate MCS, NDI, RV, and the like, for each TRP, e.g., when the configured maximum number of codewords scheduled by the DCI is two.

[0199] The HARQ process number field 515 generally carries or otherwise conveys an indication of a number or identifier associated with each HARQ process configured by the DCI. Moreover, the HARQ timing field 520 generally carries or otherwise conveys an

indication of a timing parameter for each HARQ process, e.g., an indication of timing for transmission of a feedback signal. Broadly, the DAI field 525 may carry or otherwise convey an indication of a number or index identifying all of the downlink data being communicated during the downlink transmission that has been bundled into one HARQ ACK/NACK transmission. The DMRS port configuration field 530 may generally carry or otherwise convey an indication of a DMRS port group configuration for the TRPs participating in the downlink transmission.

[0200] It is to be understood that different configurations may be implemented with respect to the DMRS port configuration field 530. In some aspects, this may include the indication of the DMRS configuration being moved to the portion of the DCI message that indicates the DMRS port group-specific parameter set. For example, the DMRS port configuration information illustrated in DCI configuration 500 as being provided in a separate field may, instead, be indicated in the DMRS1 configuration information field 535 and DMRS2 configuration information field 540 (not shown). As one non-limiting example, the UE may be preconfigured with available sets of DMRS port groups, with each DMRS port group including one or more DMRS ports. In this example, the DMRS port configuration may include a bit, a bitmap, or other field that indicates which DMRS port group(s) is/are activated for the downlink transmission. In another example, the UE may not be preconfigured with the available sets of DMRS port groups. In this example, the DMRS port configuration may identify which DMRS port groups are being activated for the downlink transmission. The DMRS port configuration may further include one or more configuration parameters for the DMRS port group(s) used for the downlink transmission.

[0201] The DMRS1 configuration information field 535 generally carries or otherwise indicates a parameter set that are specific to a first DMRS port group. In some aspects, the first DMRS port group may be associated with a particular TRP, such as TRP1, for the downlink transmission. Similarly, the DMRS2 configuration information field 540 generally carries or otherwise indicate a parameter set that are specific to a second DMRS port group. In some aspects, the second DMRS port group may be associated with a particular TRP, such as TRP2, for the downlink transmission. For example, each DMRS specific configuration information field 535 and 540 may provide an indication of a time/frequency resource allocation, QCL information, rate matching configuration, and the like, for the corresponding TRP to use during the downlink transmission. In some aspects, the QCL information may be

a resource-specific QCL, e.g., may only be applied to the resources indicated in the time/frequency resource allocation carried by the TRP associated with the DMRS port group specific configuration field. In DCI configuration 500, the indication of the DMRS port group configuration is moved to the common parameter set. Again, in the format 2 (option 2) DCI configuration 500, different resources may be allocated for each TRPs participating in the downlink transmission.

[0202] Generally, the codeword information field 510, the HARQ process number field 515, the HARQ timing field 520, the DAI field 525, and/or the DMRS port configuration field 530 may be considered a common parameter set that is applicable to each TRP participating in the downlink transmission. Generally, each of the DMRS1 configuration information field 535 and DMRS2 configuration information field 540 may be considered a DMRS port group specific parameter set.

[0203] Accordingly, the UE may receive a DCI message configured according to DCI configuration 500 and use the mode indicator to determine the transmission scheme for the downlink transmission and the common parameter set and one or more DMRS port group specific parameter sets to identify the QCL information, the rate matching configuration, the resource allocation, and the like, for each DMRS port group. The UE may receive the downlink transmission from TRP1 and TRP2 according to the transmission scheme and other parameters identified from DCI configuration 500.

[0204] FIG. 6 illustrates an example of a multi-stage DCI configuration 600 that supports single and multi-stage DCI design for multiple transceiver nodes in accordance with aspects of the present disclosure. In some examples, multi-stage DCI configuration 600 may implement aspects of wireless communication systems 100/200. Aspects of multi-stage DCI configuration 600 may be implemented by a base station and/or UE, which may be examples of the corresponding devices described herein. Generally, multi-stage DCI configuration 600 illustrates a DCI configuration which may be used in a multi-stage DCI design.

[0205] As discussed above, the UE may receive a DCI message (e.g., a first DCI message 605) that carries or otherwise conveys an indication of a mode indicator, parameter sets that are common to each TRP participating in the downlink transmission, and one or more parameter sets that are specific to a particular DMRS port group, e.g., a DMRS port group associated with a TRP participating in the downlink transmission. In some aspects, the first

DCI message may include a first DMRS port group-specific parameter set as well as an indication of a resource for receiving a second DCI message 610. The second DCI message 610 may carry or otherwise convey an indication of a second DMRS port group-specific parameter set. Multi-stage DCI configuration 600 illustrates one example of how the first DCI message 605 and the second DCI message 610 can be configured for transmission to the UE, and used by the UE to determine the transmission scheme and/or associated communication parameters to use during the downlink transmission.

[0206] The first DCI message 605 may include a codeword information field 615, a HARQ process number field 620, a HARQ timing field 625, a DAI field 630, a resource allocation field 635 for a first DMRS port group (DMRS1), a DMRS port configuration field 640 for DMRS1, a QCL information field 645 for DMRS1, a rate matching pattern or configuration for DMRS1, a mode indicator field 655, a scheduling (e.g., resource allocation or indication) field 660 for the second DCI message 610, and (if a third DMRS port group is applicable, e.g., associated with a third TRP participating in the downlink transmission), a scheduling field 665 for a third DCI message (not shown). Broadly, the mode indicator field 655 may explicitly or implicitly indicate a transmission scheme being used for the downlink transmission. For example, the mode indicator field 665 may include one or more bits or fields that identifies a transmission scheme, identifies a number or index associated with a transmission scheme, and the like. Implicitly, the transmission scheme may be indicated based at least in part on a CRC scrambling sequence associated with the first DCI message 605. Generally, the transmission scheme may indicate otherwise be associated with a link or association between a codeword and a DMRS port group for one or more TRPs participating in the downlink transmission.

[0207] Codeword information field 615 may generally convey an indication of one or codeword communication parameters being used for the downlink transmission. Generally, codeword information field 615 may carry or otherwise provide an indication of a MCS, a NDI, a RV, and the like, for each TRP participating in the downlink transmission. In some examples, the codeword information field 615 may carry or otherwise provide an indication of a separate MCS, NDI, RV, and the like, for each TRP, e.g., when the configured maximum number of codewords scheduled by the DCI is two.

[0208] The HARQ process number field 620 generally carries or otherwise conveys an indication of a number or identifier associated with each HARQ process configured by the DCI. Moreover, the HARQ timing field 625 generally carries or otherwise conveys an indication of a timing parameter for each HARQ process, e.g., an indication of timing for transmission of a feedback signal. Broadly, the DAI field 630 may carry or otherwise convey an indication of a number or index identifying all of the downlink data being communicated during the downlink transmission that has been bundled into one HARQ ACK/NACK transmission. The DMRS port configuration field 640 may generally carry or otherwise convey an indication of a DMRS port configuration for the first DMRS port group, e.g., the DMRS port group associated with TRP1. The rate matching pattern or configuration field 650 may carry or otherwise provide an indication of the rate matching pattern to be used by TRP1 during the downlink transmission.

[0209] Generally, the scheduling field 660 (and scheduling field 665 when applicable) may generally identify the resource allocation (e.g., time/frequency resources) of where the second DCI message (and third DCI message, when applicable) can be detected. For example, the scheduling field 660 may indicate a starting resource block position of the second DCI message 610. In some aspects, the starting resource block position of the second DCI message may be based or otherwise associated with a component carrier and/or cell identifier for each transceiver node.

[0210] The UE may receive the first DCI message 605 and use the mode indicator to determine the transmission scheme for the downlink transmission. Moreover, the UE may use the other field(s) to determine the various communication parameters (common to all TRPs and specific to the first TRP) that will be used during the downlink transmission, e.g., MCS, rate matching, etc. The UE may use the scheduling field 660 to determine where to detect the second DCI message 610. The contents of the second DCI message 610 may be dependent on the format for the DCI messages. Generally, each of the different formats for the second DCI message 610 may carry or otherwise convey an indication of a second DMRS port group specific parameter set for TRP2 (or a third DMRS port group specific parameter set when TRP3 participates in the downlink transmission).

[0211] In a first format where the same resource allocations are used for TRP1 and TRP2, the second DCI message 610 may carry or otherwise convey an indication of a DMRS port

field 670 that identifies the DMRS port group configuration for TRP2, a QCL information field 675 for TRP2, and a rate matching configuration field 680 for TRP2.

[0212] In a second format (option 1) where different resources allocations are made for TRP1 and TRP2, the second DCI message 610 may carry or otherwise convey an indication of the DMRS port field 670 that identifies the DMRS port group configuration for TRP2, the QCL information field 675 for TRP2, the rate matching configuration field 680 for TRP2, and a resource allocation field 685 that identifies time/frequency resources for TRP2 to use during the downlink transmission.

[0213] In a second format (option 2) where different resources allocations are made for TRP1 and TRP2, the second DCI message 610 may carry or otherwise convey an indication of the QCL information field 675 for TRP2, the rate matching configuration field 680 for TRP2, and the resource allocation field 685 that identifies time/frequency resources for TRP2 to use during the downlink transmission.

[0214] Accordingly, the UE may receive the first DCI message 605 and the second DCI message 610, use the mode indicator to determine the transmission scheme for the downlink transmission and the common parameter set and one or more DMRS port group specific parameter sets to identify the QCL information, the rate matching configuration, the resource allocation, and the like, for each DMRS port group. The UE may receive the downlink transmission from TRP1 and TRP2 according to the transmission scheme and other parameters identified from multi-stage DCI configuration 600.

[0215] FIG. 7 illustrates an example of a multi-stage DCI configuration 700 that supports single and multi-stage DCI design for multiple transceiver nodes in accordance with aspects of the present disclosure. In some examples, multi-stage DCI configuration 700 may implement aspects of wireless communication systems 100/200. Aspects of multi-stage DCI configuration 700 may be implemented by a base station and/or UE, which may be examples of the corresponding devices described herein. Generally, multi-stage DCI configuration 700 illustrates a DCI configuration which may be used in a multi-stage DCI design.

[0216] As discussed above, the UE may receive a DCI message (e.g., a first DCI message 705) that carries or otherwise conveys an indication of a mode indicator, parameter sets that are common to each TRP participating in the downlink transmission, and one or more parameter sets that are common to a particular DMRS port group, e.g., a DMRS port group

associated with a TRP participating in the downlink transmission. In some aspects, the first DCI message 705 may include a first DMRS port group-specific parameter set as well as an indication of a resource for receiving a second DCI message 710. The second DCI message 710 may carry or otherwise convey an indication of a second DMRS port group-specific parameter set. Multi-stage DCI configuration 700 illustrates one example of how the first DCI message 705 and the second DCI message 710 can be configured for transmission to the UE, and used by the UE to determine the transmission scheme and/or associated communication parameters to use during the downlink transmission.

[0217] The first DCI message 705 may include a codeword information field 715, a HARQ process number field 720, a HARQ timing field 725, a DAI field 730, a resource allocation field 735 for a first DMRS port group (DMRS1), a DMRS port configuration field 740 that is common for all DMRS port groups, a QCL information field 745 for DMRS1, a rate matching pattern or configuration for DMRS1, a mode indicator field 755, a scheduling (e.g., resource allocation or indication) field 760 for the second DCI message 710, and (if a third DMRS port group is applicable, e.g., associated with a third TRP participating in the downlink transmission), a scheduling field 765 for a third DCI message (not shown). Broadly, the mode indicator field 755 may explicitly or implicitly indicate a transmission scheme being used for the downlink transmission. For example, the mode indicator field 755 may include one or more bits or fields that identifies a transmission scheme, identifies a number or index associated with a transmission scheme, and the like. Implicitly, the transmission scheme may be indicated based at least in part on a CRC scrambling sequence associated with the first DCI message 705. Generally, the transmission scheme may indicate otherwise be associated with a link or association between a codeword and a DMRS port group for one or more TRPs participating in the downlink transmission.

[0218] Codeword information field 715 may generally convey an indication of one or codeword communication parameters being used for the downlink transmission. Generally, codeword information field 715 may carry or otherwise provide an indication of a MCS, a NDI, a RV, and the like, for each TRP participating in the downlink transmission. In some examples, the codeword information field 715 may carry or otherwise provide an indication of a separate MCS, NDI, RV, and the like, for each TRP, e.g., when the configured maximum number of codewords scheduled by the DCI is two.

[0219] The HARQ process number field 720 generally carries or otherwise conveys an indication of a number or identifier associated with each HARQ process configured by the DCI. Moreover, the HARQ timing field 725 generally carries or otherwise conveys an indication of a timing parameter for each HARQ process, e.g., an indication of timing for transmission of a feedback signal. Broadly, the DAI field 730 may carry or otherwise convey an indication of a number or index identifying all of the downlink data being communicated during the downlink transmission that has been bundled into one HARQ ACK/NACK transmission. The DMRS port configuration field 740 may generally carry or otherwise convey an indication of a DMRS port configuration for each DMRS port group, e.g., the DMRS port groups associated with their respective TRPs. The rate matching pattern or configuration field 750 may carry or otherwise provide an indication of the rate matching pattern to be used by TRP1 during the downlink transmission.

[0220] Generally, the scheduling field 760 (and scheduling field 765 when applicable) may generally identify the resource allocation (e.g., time/frequency resources) of where the second DCI message 710 (and third DCI message, when applicable) can be detected. For example, the scheduling field 760 may indicate a starting resource block position of the second DCI message 710. In some aspects, the starting resource block position of the second DCI message may be based or otherwise associated with a component carrier and/or cell identifier for each transceiver node.

[0221] The UE may receive the first DCI message 705 and use the mode indicator to determine the transmission scheme for the downlink transmission. Moreover, the UE may use the other field(s) to determine the various communication parameters (common to all TRPs and/or specific to the first TRP) that will be used during the downlink transmission, e.g., MCS, rate matching, etc. The UE may use the scheduling field 760 to determine where to detect the second DCI message 710. The contents of the second DCI message 710 may be dependent on the format for the DCI messages. Generally, each of the different formats for the second DCI message 710 may carry or otherwise convey an indication of a second DMRS port group specific parameter set for TRP2 (or a third DMRS port group specific parameter set when TRP3 participates in the downlink transmission).

[0222] In a first format where the same resource allocations are used for TRP1 and TRP2, the second DCI message 710 may carry or otherwise convey an indication of a QCL

information field 775 for TRP2 and a rate matching configuration field 780 for TRP2. The DMRS port field that identifies the DMRS port group configuration for TRP2 is conveyed in the common DMRS port field 740 of the first DCI message 705.

5 [0223] In a second format where different resources allocations are made for TRP1 and TRP2, the second DCI message 710 may carry or otherwise convey an indication of the QCL information field 775 for TRP2, the rate matching configuration field 780 for TRP2, and a resource allocation field 785 that identifies time/frequency resources for TRP2 to use during the downlink transmission. The DMRS port field that identifies the DMRS port group configuration for TRP2 is conveyed in the common DMRS port field 740 of the first DCI
10 message 705.

[0224] Accordingly, the UE may receive the first DCI message 705 and the second DCI message 710, use the mode indicator to determine the transmission scheme for the downlink transmission and the common parameter set and one or more DMRS port group specific parameter sets to identify the QCL information, the rate matching configuration, the resource
15 allocation, and the like, for each DMRS port group. The UE may receive the downlink transmission from TRP1 and TRP2 according to the transmission scheme and other parameters identified from multi-stage DCI configuration 700.

[0225] FIG. 8 illustrates an example of a process 800 that supports single and multi-stage DCI design for multiple transceiver nodes in accordance with aspects of the present
20 disclosure. In some examples, process 800 may implement aspects of wireless communication systems 100/200, DCI configurations 300/400/500, and/or multi-stage DCI configurations 600/700. Aspects of process 800 may be implemented by a UE 805 and/or a transceiver node 810, which may be examples of the corresponding devices described herein. In some aspects, transceiver node 810 may also be referred to as a TRP or a base station.

25 [0226] At 815, transceiver node 810 may transmit (and UE 805 may receive) a DCI message configuring a downlink transmission for UE 805. In some aspects, the DCI message may include a mode indicator, a common parameter set for the one or more DMRS port groups, and one or more DMRS port group specific parameter sets.

[0227] At 820, UE 805 may determine the transmission scheme for the downlink
30 transmission. In some aspects, a transmission scheme may be based on an association between the one or more DMRS port groups and one or more codewords being

communicated during the downlink transmission. UE 805 may determine the transmission scheme based at least in part on the mode indicator.

[0228] At 825, UE 805 may determine the QCL information, rate matching configuration, resource allocation, and the like, from the DCI message. In some aspects, UE 805 may
5 determine the QCL information, rate matching configuration, and/or resource allocation based on the common parameter set for the one or more DMRS port groups and the one or more DMRS port group specific parameter sets indicated in the DCI message. In some aspects, UE 805 may determine the QC information, rate matching configuration, and/or resource allocation for at least one (or each of the) DMRS port group. Transceiver node 810
10 may perform the downlink transmission to UE 805 according to the transmission scheme and using one or more parameter sets.

[0229] FIG. 9 shows a block diagram 900 of a device 905 that supports single and multi-stage DCI design for multiple transceiver nodes in accordance with aspects of the present disclosure. The device 905 may be an example of aspects of a UE 115 as described herein.
15 The device 905 may include a receiver 910, a communications manager 915, and a transmitter 920. The device 905 may also include a processor. Each of these components may be in communication with one another (e.g., via one or more buses).

[0230] The receiver 910 may receive information such as packets, user data, or control information associated with various information channels (e.g., control channels, data
20 channels, and information related to single and multi-stage DCI design for multiple transceiver nodes, etc.). Information may be passed on to other components of the device 905. The receiver 910 may be an example of aspects of the transceiver 1220 described with reference to FIG. 12. The receiver 910 may utilize a single antenna or a set of antennas.

[0231] The communications manager 915 may receive a DCI message configuring a
25 downlink transmission of one or more codewords (CWs) associated with one or more DMRS port groups, where the DCI message includes a mode indicator, a common parameter set for the one or more DMRS port groups, and one or more DMRS port group-specific parameter set, determine, based on the mode indicator, a transmission scheme for the downlink transmission, where the transmission scheme includes an association between the one or
30 more DMRS port groups and the one or more CWs, and determine, based on at least one of the common parameter set for the one or more DMRS port groups, the one or more DMRS

port group-specific parameter set, or a combination thereof, at least one of a QCL information, a rate matching configuration, a resource allocation, or a combination thereof, for at least one DMRS port group. The communications manager 915 may be an example of aspects of the communications manager 1210 described herein.

5 [0232] The communications manager 915, or its sub-components, may be implemented in hardware, code (e.g., software or firmware) executed by a processor, or any combination thereof. If implemented in code executed by a processor, the functions of the communications manager 915, or its sub-components may be executed by a general-purpose processor, a DSP, an application-specific integrated circuit (ASIC), a FPGA or other programmable logic
10 device, discrete gate or transistor logic, discrete hardware components, or any combination thereof designed to perform the functions described in the present disclosure.

[0233] The communications manager 915, or its sub-components, may be physically located at various positions, including being distributed such that portions of functions are implemented at different physical locations by one or more physical components. In some
15 examples, the communications manager 915, or its sub-components, may be a separate and distinct component in accordance with various aspects of the present disclosure. In some examples, the communications manager 915, or its sub-components, may be combined with one or more other hardware components, including but not limited to an input/output (I/O) component, a transceiver, a network server, another computing device, one or more other
20 components described in the present disclosure, or a combination thereof in accordance with various aspects of the present disclosure.

[0234] The transmitter 920 may transmit signals generated by other components of the device 905. In some examples, the transmitter 920 may be collocated with a receiver 910 in a transceiver module. For example, the transmitter 920 may be an example of aspects of the
25 transceiver 1220 described with reference to FIG. 12. The transmitter 920 may utilize a single antenna or a set of antennas.

[0235] FIG. 10 shows a block diagram 1000 of a device 1005 that supports single and multi-stage DCI design for multiple transceiver nodes in accordance with aspects of the present disclosure. The device 1005 may be an example of aspects of a device 905, or a UE
30 115 as described herein. The device 1005 may include a receiver 1010, a communications

manager 1015, and a transmitter 1035. The device 1005 may also include a processor. Each of these components may be in communication with one another (e.g., via one or more buses).

[0236] The receiver 1010 may receive information such as packets, user data, or control information associated with various information channels (e.g., control channels, data channels, and information related to single and multi-stage DCI design for multiple transceiver nodes, etc.). Information may be passed on to other components of the device 1005. The receiver 1010 may be an example of aspects of the transceiver 1220 described with reference to FIG. 12. The receiver 1010 may utilize a single antenna or a set of antennas.

[0237] The communications manager 1015 may be an example of aspects of the communications manager 915 as described herein. The communications manager 1015 may include a DCI manager 1020, a mode indicator 1025, and a transmission scheme manager 1030. The communications manager 1015 may be an example of aspects of the communications manager 1210 described herein.

[0238] The DCI manager 1020 may receive a DCI message configuring a downlink transmission of one or more CWs associated with one or more DMRS port groups, where the DCI message includes a mode indicator, a common parameter set for the one or more DMRS port groups, and one or more DMRS port group-specific parameter set.

[0239] The mode indicator 1025 may determine, based on the mode indicator, a transmission scheme for the downlink transmission, where the transmission scheme includes an association between the one or more DMRS port groups and the one or more CWs.

[0240] The transmission scheme manager 1030 may determine, based on at least one of the common parameter set for the one or more DMRS port groups, the one or more DMRS port group-specific parameter set, or a combination thereof, at least one of a QCL information, a rate matching configuration, a resource allocation, or a combination thereof, for at least one DMRS port group.

[0241] The transmitter 1035 may transmit signals generated by other components of the device 1005. In some examples, the transmitter 1035 may be collocated with a receiver 1010 in a transceiver module. For example, the transmitter 1035 may be an example of aspects of the transceiver 1220 described with reference to FIG. 12. The transmitter 1035 may utilize a single antenna or a set of antennas.

[0242] FIG. 11 shows a block diagram 1100 of a communications manager 1105 that supports single and multi-stage DCI design for multiple transceiver nodes in accordance with aspects of the present disclosure. The communications manager 1105 may be an example of aspects of a communications manager 915, a communications manager 1015, or a communications manager 1210 described herein. The communications manager 1105 may include a DCI manager 1110, a mode indicator 1115, a transmission scheme manager 1120, a DCI configuration manager 1125, a port-specific parameter manager 1130, a mode indicator manager 1135, a transmission scheme configuration manager 1140, a transmission scheme case manager 1145, a RA manager 1150, and a multi-stage DCI manager 1155. Each of these modules may communicate, directly or indirectly, with one another (e.g., via one or more buses).

[0243] The DCI manager 1110 may receive a DCI message configuring a downlink transmission of one or more CWs associated with one or more DMRS port groups, where the DCI message includes a mode indicator, a common parameter set for the one or more DMRS port groups, and one or more DMRS port group-specific parameter set. In some cases, the DCI message includes one or more bits or fields configured to indicate the mode indicator.

[0244] The mode indicator 1115 may determine, based on the mode indicator, a transmission scheme for the downlink transmission, where the transmission scheme includes an association between the one or more DMRS port groups and the one or more CWs.

[0245] The transmission scheme manager 1120 may determine, based on at least one of the common parameter set for the one or more DMRS port groups, the one or more DMRS port group-specific parameter set, or a combination thereof, at least one of a QCL information, a rate matching configuration, a resource allocation, or a combination thereof, for at least one DMRS port group.

[0246] The DCI configuration manager 1125 may determine, based on a first DMRS port group-specific parameter set, at least one of a first QCL information, a first rate matching configuration, a first resource allocation, or a combination thereof, for a first DMRS port group. In some examples, the DCI configuration manager 1125 may determine, based on a second DMRS port group-specific parameter set, at least one of a second QCL information, a second rate matching configuration, a second resource allocation, or a combination thereof, for a second DMRS port group. In some cases, the common parameter set includes an

indication of at least one of a CW configuration for each CW being communicated during the downlink transmission, a HARQ process number, a HARQ timing parameter, a downlink assignment index, a frequency resource allocation common to each DMRS port group, a time resource allocation common to each DMRS port group, a DMRS port grouping, or a combination thereof.

[0247] The port-specific parameter manager 1130 may identify one or more DCI message formats based on the one or more DMRS port group-specific parameter sets. In some examples, the port-specific parameter manager 1130 may determine the DCI message format for the DCI message based on at least one of a CRC scrambling sequence associated with each of the one or more DCI message formats, a payload size of each of the one or more DCI message formats, or a combination thereof. In some cases, each of the one or more DMRS port group-specific parameter set includes an indication of at least one of a frequency domain resource allocation, a time domain resource allocation, the QCL information, the rate matching configuration, or combinations thereof, for an associated DMRS port group.

[0248] The mode indicator manager 1135 may identify a scrambling sequence used to scramble the DCI message, where the scrambling sequence includes the mode indicator.

[0249] The transmission scheme configuration manager 1140 may receive a signal indicating a set of supported transmission schemes. In some examples, the transmission scheme configuration manager 1140 may identify the transmission scheme from the set of supported transmission schemes based on the mode indicator.

[0250] The transmission scheme case manager 1145 may aggregate, based on an index associated with each DMRS port of the first DMRS port group and the second DMRS port group, the DMRS port of the first DMRS port group and the second DMRS port group to form an aggregated DMRS port. In some examples, the transmission scheme case manager 1145 may aggregate, based on an index associated with each resource element associated with a frequency resource allocation and a time resource allocation associated with the first DMRS port group and second DMRS port group, a frequency resource allocation and a time resource allocation associated with the first DMRS port group and the second DMRS port group to form an aggregated frequency resource allocation and an aggregated time resource allocation.

[0251] In some examples, the transmission scheme case manager 1145 may map a data stream of the TB associated with the CW according to the order including one or more layers associated with the aggregated DMRS port, then the aggregated frequency resource allocation, and then the aggregated time resource allocation. In some cases, the transmission scheme includes a first TB associated with a first CW being communicated using a first DMRS port group and a second TB associated with a second CW being communicated using a second DMRS port group.

[0252] In some cases, a first data stream associated with the first TB that is associated with the first CW is mapped to the first DMRS port group according to an order including a first layer of the first DMRS port group, then a frequency resource allocation of the first DMRS port group, and then a time resource allocation of the first DMRS port group.

[0253] In some cases, a second data stream associated with the second TB that is associated with the second CW is mapped to the second DMRS port group according to an order including a second layer of the second DMRS port group, then a frequency resource allocation of the second DMRS port group, and then a time resource allocation of the second DMRS port group.

[0254] In some cases, the transmission scheme includes a TB associated with a first CW being communicated using a first DMRS port group and a second DMRS port group, where a first version of the CW is communicated from the first DMRS port group and a second version of the CW is communicated from the second DMRS port group.

[0255] In some cases, the first and second versions of the CW include a different redundancy version or a different mapping function between the TB and the DMRS port group.

[0256] In some cases, a first data stream associated with a first version of the TB that is associated with the CW is mapped to the first DMRS port group according to an order including a first layer of the first DMRS port group, then a frequency resource allocation of the first DMRS port group, and then a time resource allocation of the first DMRS port group.

[0257] In some cases, a second data stream associated with a second version of the TB that is associated with the CW is mapped to the second DMRS port group according to an order including a second layer of the second DMRS port group, then a frequency resource

allocation of the second DMRS port group, and then a time resource allocation of the second DMRS port group.

[0258] In some cases, the transmission scheme includes a TB associated with a first CW being communicated using a first DMRS port group and a second DMRS port group, where a
5 first portion of the CW is communicated from the first DMRS port group and a second portion of the CW is communicated from the second DMRS port group.

[0259] In some cases, a first data stream associated with a first portion of the TB that is associated with the CW is mapped to the first DMRS port group according to an order including a first layer of the first DMRS port group, then a frequency resource allocation of
10 the first DMRS port group, and then a time resource allocation of the first DMRS port group.

[0260] In some cases, a second data stream associated with a second portion of the TB that is associated with the CW is mapped to the second DMRS port group according to an order including a second layer of the second DMRS port group, then a frequency resource allocation of the second DMRS port group, and then a time resource allocation of the second
15 DMRS port group.

[0261] The RA manager 1150 may determine that a first DMRS port group and a second DMRS port group are configured with a same frequency resource allocation and time resource allocation.

[0262] In some examples, the RA manager 1150 may determine that the first DMRS port
20 group and the second DMRS port group are configured with different DMRS ports.

[0263] In some examples, the RA manager 1150 may determine that a first DMRS port group and a second DMRS port group are configured with a different frequency resource allocation and time resource allocation.

[0264] In some examples, the RA manager 1150 may determine that the first DMRS port
25 group is active in the frequency resource allocation and time resource allocation associated with the first DMRS port group.

[0265] In some examples, the RA manager 1150 may determine that the second DMRS port group is active in the frequency resource allocation and time resource allocation associated with the second DMRS port group.

[0266] In some examples, the RA manager 1150 may determine that a first DMRS port group and a second DMRS port group share one or more DMRS ports, but are configured with a different frequency resource allocation and time resource allocation.

5 [0267] In some examples, the RA manager 1150 may determine that at least one of a first QCL information, a first rate matching configuration, or a combination thereof, is applied to the shared one or more DMRS ports using a frequency resource allocation and time resource allocation associated with the first DMRS port group.

10 [0268] In some examples, the RA manager 1150 may determine that at least one of a second QCL information, a second rate matching configuration, or a combination thereof, is applied to the shared one or more DMRS ports using a frequency resource allocation and time resource allocation associated with the second DMRS port group.

[0269] The multi-stage DCI manager 1155 may receive the second DCI message that includes an indication of a second DMRS port group-specific parameter set.

15 [0270] In some examples, the multi-stage DCI manager 1155 may determine, based on the starting resource block for the second DCI message, a payload size for the second DCI message.

[0271] In some examples, the multi-stage DCI manager 1155 may determine, based on the payload size, whether the resource allocation for the first DMRS port group is the same as or different from the resource allocation for the second DMRS port group.

20 [0272] In some examples, the multi-stage DCI manager 1155 may determine, upon a determination that the resource allocation for the first DMRS port group is the same as the resource allocation for the second DMRS port group, that the second DMRS port group-specific parameter set does not indicate the resource allocation for the second DMRS port group.

25 [0273] In some examples, the multi-stage DCI manager 1155 may determine, upon a determination that the resource allocation for the first DMRS port group is different from the resource allocation for the second DMRS port group, that the second DMRS port group-specific parameter set does indicate the resource allocation for the second DMRS port group.

30 [0274] In some examples, the multi-stage DCI manager 1155 may determine, based on the starting resource block for the second DCI message, a resource occupancy for the second

DCI message. In some examples, the multi-stage DCI manager 1155 may determine, based on the resource occupancy, whether the resource allocation for the first DMRS port group is the same as or different from the resource allocation for the second DMRS port group. In some examples, the multi-stage DCI manager 1155 may determine, based on the mode indicator, a payload size of the second DCI message conveying the second DMRS port group-specific parameter set for the second DMRS port group.

[0275] In some examples, the multi-stage DCI manager 1155 may determine, based on the payload size, the resource allocation for the second DCI message. In some examples, the multi-stage DCI manager 1155 may determine, based on one or more bits or fields in the DCI message that explicitly indicates the resource for the second DCI message, a resource occupancy for the second DCI message. In some examples, the multi-stage DCI manager 1155 may determine that the second DCI message could not be decoded. In some examples, the multi-stage DCI manager 1155 may determine, based on the transmission scheme, that the first DMRS port group and at least one port of the second DMRS port group are associated with different portions of a TB of a CW. In some examples, the multi-stage DCI manager 1155 may transmit a signal indicating that at least the second DCI message or the TB could not be decoded.

[0276] In some examples, the multi-stage DCI manager 1155 may determine, based on the transmission scheme, that the first DMRS port group and at least one DMRS port of the second DMRS port group are associated with different TBs. In some examples, the multi-stage DCI manager 1155 may transmit a first signal indicating a decoding result of the TB associated with the first DMRS port group. In some examples, the multi-stage DCI manager 1155 may transmit a second signal indicating that at least the second DCI message or the TB associated with the second DMRS port group could not be decoded. In some examples, the multi-stage DCI manager 1155 may determine, based on the transmission scheme, that the first DMRS port group and at least one DMRS port of the second DMRS port group are associated with different versions of a TB associated with a CW. In some examples, the multi-stage DCI manager 1155 may transmit a first signal indicating a decoding result of the TB. In some examples, the multi-stage DCI manager 1155 may transmit a second signal indicating that the second DCI message could not be decoded. In some cases, the indication of the resource includes an indication of a starting resource block for receiving the second DCI message. In some cases, the indication of the resource includes an indication of a

component carrier identifier or a cell identifier, where the component carrier identifier or the cell identifier conveys an indication of a starting resource block for receiving the second DCI message.

[0277] FIG. 12 shows a diagram of a system 1200 including a device 1205 that supports
5 single and multi-stage DCI design for multiple transceiver nodes in accordance with aspects of the present disclosure. The device 1205 may be an example of or include the components of device 905, device 1005, or a UE 115 as described herein. The device 1205 may include components for bi-directional voice and data communications including components for transmitting and receiving communications, including a communications manager 1210, an
10 I/O controller 1215, a transceiver 1220, an antenna 1225, memory 1230, and a processor 1240. These components may be in electronic communication via one or more buses (e.g., bus 1245).

[0278] The communications manager 1210 may receive a DCI message configuring a
5 downlink transmission of one or more CWs associated with one or more DMRS port groups, where the DCI message includes a mode indicator, a common parameter set for the one or more DMRS port groups, and one or more DMRS port group-specific parameter set, determine, based on the mode indicator, a transmission scheme for the downlink transmission, where the transmission scheme includes an association between the one or more DMRS port
15 groups and the one or more CWs, and determine, based on at least one of the common parameter set for the one or more DMRS port groups, the one or more DMRS port group-specific parameter set, or a combination thereof, at least one of a QCL information, a rate matching configuration, a resource allocation, or a combination thereof, for at least one
20 DMRS port group.

[0279] The I/O controller 1215 may manage input and output signals for the device 1205.
25 The I/O controller 1215 may also manage peripherals not integrated into the device 1205. In some cases, the I/O controller 1215 may represent a physical connection or port to an external peripheral. In some cases, the I/O controller 1215 may utilize an operating system such as iOS®, ANDROID®, MS-DOS®, MS-WINDOWS®, OS/2®, UNIX®, LINUX®, or another known operating system. In other cases, the I/O controller 1215 may represent or interact
30 with a modem, a keyboard, a mouse, a touchscreen, or a similar device. In some cases, the I/O controller 1215 may be implemented as part of a processor. In some cases, a user may

interact with the device 1205 via the I/O controller 1215 or via hardware components controlled by the I/O controller 1215.

[0280] The transceiver 1220 may communicate bi-directionally, via one or more antennas, wired, or wireless links as described above. For example, the transceiver 1220 may represent
5 a wireless transceiver and may communicate bi-directionally with another wireless transceiver. The transceiver 1220 may also include a modem to modulate the packets and provide the modulated packets to the antennas for transmission, and to demodulate packets received from the antennas.

[0281] In some cases, the wireless device may include a single antenna 1225. However,
10 in some cases the device may have more than one antenna 1225, which may be capable of concurrently transmitting or receiving multiple wireless transmissions.

[0282] The memory 1230 may include RAM and ROM. The memory 1230 may store computer-readable, computer-executable code 1235 including instructions that, when
15 executed, cause the processor to perform various functions described herein. In some cases, the memory 1230 may contain, among other things, a BIOS which may control basic hardware or software operation such as the interaction with peripheral components or devices.

[0283] The processor 1240 may include an intelligent hardware device, (e.g., a general-purpose processor, a DSP, a CPU, a microcontroller, an ASIC, an FPGA, a programmable logic device, a discrete gate or transistor logic component, a discrete hardware component, or
20 any combination thereof). In some cases, the processor 1240 may be configured to operate a memory array using a memory controller. In other cases, a memory controller may be integrated into the processor 1240. The processor 1240 may be configured to execute computer-readable instructions stored in a memory (e.g., the memory 1230) to cause the device 1205 to perform various functions (e.g., functions or tasks supporting single and
25 multi-stage DCI design for multiple transceiver nodes).

[0284] The code 1235 may include instructions to implement aspects of the present disclosure, including instructions to support wireless communications. The code 1235 may be stored in a non-transitory computer-readable medium such as system memory or other type of
30 memory. In some cases, the code 1235 may not be directly executable by the processor 1240 but may cause a computer (e.g., when compiled and executed) to perform functions described herein.

[0285] FIG. 13 shows a block diagram 1300 of a device 1305 that supports single and multi-stage DCI design for multiple transceiver nodes in accordance with aspects of the present disclosure. The device 1305 may be an example of aspects of a base station 105 as described herein. The device 1305 may include a receiver 1310, a communications manager 1315, and a transmitter 1320. The device 1305 may also include a processor. Each of these components may be in communication with one another (e.g., via one or more buses).

[0286] The receiver 1310 may receive information such as packets, user data, or control information associated with various information channels (e.g., control channels, data channels, and information related to single and multi-stage DCI design for multiple transceiver nodes, etc.). Information may be passed on to other components of the device 1305. The receiver 1310 may be an example of aspects of the transceiver 1620 described with reference to FIG. 16. The receiver 1310 may utilize a single antenna or a set of antennas.

[0287] The communications manager 1315 may determine that a downlink transmission to a UE is to occur, the downlink transmission including one or more CWs associated with one or more DMRS port groups, configure a DCI message to indicate a mode indicator, a common parameter set for the one or more DMRS port groups, and one or more DMRS port group-specific parameter set, where the mode indicator provides an indication of the association between the one or more DMRS port groups and the one or more CWs being communicated during the downlink transmission, and transmit the DCI message to configure the downlink transmission. The communications manager 1315 may be an example of aspects of the communications manager 1610 described herein.

[0288] The communications manager 1315, or its sub-components, may be implemented in hardware, code (e.g., software or firmware) executed by a processor, or any combination thereof. If implemented in code executed by a processor, the functions of the communications manager 1315, or its sub-components may be executed by a general-purpose processor, a DSP, an ASIC, a FPGA or other programmable logic device, discrete gate or transistor logic, discrete hardware components, or any combination thereof designed to perform the functions described in the present disclosure.

[0289] The communications manager 1315, or its sub-components, may be physically located at various positions, including being distributed such that portions of functions are implemented at different physical locations by one or more physical components. In some

examples, the communications manager 1315, or its sub-components, may be a separate and distinct component in accordance with various aspects of the present disclosure. In some examples, the communications manager 1315, or its sub-components, may be combined with one or more other hardware components, including but not limited to an I/O component, a transceiver, a network server, another computing device, one or more other components described in the present disclosure, or a combination thereof in accordance with various aspects of the present disclosure.

[0290] The transmitter 1320 may transmit signals generated by other components of the device 1305. In some examples, the transmitter 1320 may be collocated with a receiver 1310 in a transceiver module. For example, the transmitter 1320 may be an example of aspects of the transceiver 1620 described with reference to FIG. 16. The transmitter 1320 may utilize a single antenna or a set of antennas.

[0291] FIG. 14 shows a block diagram 1400 of a device 1405 that supports single and multi-stage DCI design for multiple transceiver nodes in accordance with aspects of the present disclosure. The device 1405 may be an example of aspects of a device 1305, or a base station 105 as described herein. The device 1405 may include a receiver 1410, a communications manager 1415, and a transmitter 1435. The device 1405 may also include a processor. Each of these components may be in communication with one another (e.g., via one or more buses).

[0292] The receiver 1410 may receive information such as packets, user data, or control information associated with various information channels (e.g., control channels, data channels, and information related to single and multi-stage DCI design for multiple transceiver nodes, etc.). Information may be passed on to other components of the device 1405. The receiver 1410 may be an example of aspects of the transceiver 1620 described with reference to FIG. 16. The receiver 1410 may utilize a single antenna or a set of antennas.

[0293] The communications manager 1415 may be an example of aspects of the communications manager 1315 as described herein. The communications manager 1415 may include a transmission scheme manager 1420, a DCI manager 1425, and a downlink transmission manager 1430. The communications manager 1415 may be an example of aspects of the communications manager 1610 described herein.

[0294] The transmission scheme manager 1420 may determine that a downlink transmission to a UE is to occur, the downlink transmission including one or more CWs associated with one or more DMRS port groups.

5 [0295] The DCI manager 1425 may configure a DCI message to indicate a mode indicator, a common parameter set for the one or more DMRS port groups, and one or more DMRS port group-specific parameter set, where the mode indicator provides an indication of the association between the one or more DMRS port groups and the one or more CWs being communicated during the downlink transmission.

10 [0296] The downlink transmission manager 1430 may transmit the DCI message to configure the downlink transmission.

[0297] The transmitter 1435 may transmit signals generated by other components of the device 1405. In some examples, the transmitter 1435 may be collocated with a receiver 1410 in a transceiver module. For example, the transmitter 1435 may be an example of aspects of the transceiver 1620 described with reference to FIG. 16. The transmitter 1435 may utilize a
15 single antenna or a set of antennas.

[0298] FIG. 15 shows a block diagram 1500 of a communications manager 1505 that supports single and multi-stage DCI design for multiple transceiver nodes in accordance with aspects of the present disclosure. The communications manager 1505 may be an example of aspects of a communications manager 1315, a communications manager 1415, or a
20 communications manager 1610 described herein. The communications manager 1505 may include a transmission scheme manager 1510, a DCI manager 1515, a downlink transmission manager 1520, a DCI configuration manager 1525, a DCI format manager 1530, a mode indicator manager 1535, a transmission scheme configuration manager 1540, a transmission scheme case manager 1545, a RA manager 1550, and a multi-stage DCI manager 1555. Each
25 of these modules may communicate, directly or indirectly, with one another (e.g., via one or more buses).

[0299] The transmission scheme manager 1510 may determine that a downlink transmission to a UE is to occur, the downlink transmission including one or more CWs associated with one or more DMRS port groups.

[0300] The DCI manager 1515 may configure a DCI message to indicate a mode indicator, a common parameter set for the one or more DMRS port groups, and one or more DMRS port group-specific parameter set, where the mode indicator provides an indication of the association between the one or more DMRS port groups and the one or more CWs being communicated during the downlink transmission. In some examples, the DCI manager 1515 may configure a second DMRS port group-specific parameter set to indicate at least one of a second QCL information, a second rate matching configuration, a second resource allocation, or a combination thereof, for a second DMRS port group. In some cases, the common parameter set includes an indication of at least one of a CW configuration for each CW being communicated during the downlink transmission, a HARQ process number, a HARQ timing parameter, a downlink assignment index, a frequency resource allocation common to each DMRS port group, a time resource allocation common to each DMRS port group, a DMRS port grouping, or a combination thereof. In some cases, the DCI message includes one or more bits or fields configured to indicate the mode indicator.

[0301] The downlink transmission manager 1520 may transmit the DCI message to configure the downlink transmission.

[0302] The DCI configuration manager 1525 may configure a first DMRS port group-specific parameter set to indicate at least one of a first QCL information, a first rate matching configuration, a first resource allocation, or a combination thereof, for a first DMRS port group.

[0303] The DCI format manager 1530 may identify one or more DCI message formats based on the one or more DMRS port group-specific parameter sets. In some examples, the DCI format manager 1530 may select the DCI message format for the DCI message based on at least one of the one or more DMRS port group-specific parameter sets or the common parameter set. In some examples, the DCI format manager 1530 may scramble the DCI message using a CRC scrambling sequence associated with the DCI message format. In some cases, each of the one or more DMRS port group-specific parameter set includes an indication of at least one of a frequency domain resource allocation, a time domain resource allocation, the QCL information, the rate matching configuration, or combinations thereof, for an associated DMRS port group.

[0304] The mode indicator manager 1535 may identify a scrambling sequence used to scramble the DCI message, where the scrambling sequence indicates the mode indicator.

[0305] The transmission scheme configuration manager 1540 may transmit a signal indicating a set of supported transmission schemes. In some examples, the transmission
5 scheme configuration manager 1540 may determine the transmission scheme from the set of supported transmission schemes. In some examples, the transmission scheme configuration manager 1540 may transmit the DCI message conveying the mode indicator to indicate the transmission scheme.

[0306] The transmission scheme case manager 1545 may aggregate, based on an index
10 associated with each DMRS port of the first DMRS port group and the second DMRS port group, the DMRS port of the first DMRS port group and the second DMRS port group to form an aggregated DMRS port. In some examples, the transmission scheme case manager 1545 may aggregate, based on an index associated with each resource element associated with a frequency resource allocation and a time resource allocation, the frequency resource
15 allocation and the time resource allocation to form an aggregated frequency resource allocation and an aggregated time resource allocation.

[0307] In some examples, the transmission scheme case manager 1545 may map a data stream of the TB associated with the CW according to the order including one or more layers associated with the aggregated DMRS port, then the aggregated frequency resource allocation,
20 and then the aggregated time resource allocation. In some cases, the transmission scheme includes a first TB associated with a first CW being communicated using a first DMRS port group and a second TB associated with a second CW being communicated using a second DMRS port group. In some cases, a first data stream associated with the first TB that is associated with the first CW is mapped to the first DMRS port group according to an order
25 including a first layer of the first DMRS port group, then a frequency resource allocation of the first DMRS port group, and then a time resource allocation of the first DMRS port group. In some cases, a second data stream associated with the second TB that is associated with the second CW is mapped to the second DMRS port group according to an order including a second layer of the second DMRS port group, then a frequency resource allocation of the
30 second DMRS port group, and then a time resource allocation of the second DMRS port group.

[0308] In some cases, the transmission scheme includes a TB associated with a first CW being communicated using a first DMRS port group and a second DMRS port group, where a first version of the CW is communicated from the first DMRS port group and a second version of the CW is communicated from the second DMRS port group. In some cases, the first and second versions of the CW include a different redundancy version or a different mapping function between the TB and the DMRS port group. In some cases, a first data stream associated with a first version of the TB that is associated with the CW is mapped to the first DMRS port group according to an order including a first layer of the first DMRS port group, then a frequency resource allocation of the first DMRS port group, and then a time resource allocation of the first DMRS port group. In some cases, a second data stream associated with a second version of the TB that is associated with the CW is mapped to the second DMRS port group according to an order including a second layer of the second DMRS port group, then a frequency resource allocation of the second DMRS port group, and then a time resource allocation of the second DMRS port group.

[0309] In some cases, the transmission scheme includes a TB associated with a first CW being communicated using a first DMRS port group and a second DMRS port group, where a first portion of the CW is communicated from the first DMRS port group and a second portion of the CW is communicated from the second DMRS port group. In some cases, a first data stream associated with a first portion of the TB that is associated with the CW is mapped to the first DMRS port group according to an order including a first layer of the first DMRS port group, then a frequency resource allocation of the first DMRS port group, and then a time resource allocation of the first DMRS port group. In some cases, a second data stream associated with a second portion of the TB that is associated with the CW is mapped to the second DMRS port group according to an order including a second layer of the second DMRS port group, then a frequency resource allocation of the second DMRS port group, and then a time resource allocation of the second DMRS port group.

[0310] The RA manager 1550 may configure a first DMRS port group and a second DMRS port group with a different frequency resource allocation and time resource allocation. In some examples, the RA manager 1550 may configure the first DMRS port group and the second DMRS port group with different DMRS ports. In some examples, the RA manager 1550 may configure a first DMRS port group and a second DMRS port group with a different frequency resource allocation and time resource allocation, where the first DMRS port group

is active in the frequency resource allocation and time resource allocation associated with the first DMRS port group and the second DMRS port group is active in the frequency resource allocation and time resource allocation associated with the second DMRS port group.

[0311] In some examples, the RA manager 1550 may configure a first DMRS port group and a second DMRS port group to share one or more DMRS ports, but with a different frequency resource allocation and time resource allocation. In some examples, the RA manager 1550 may where at least one of a first QCL information, a first rate matching configuration, or a combination thereof, is applied to the shared one or more DMRS ports using a frequency resource allocation and time resource allocation associated with the first DMRS port group. In some examples, the RA manager 1550 may where at least one of a second QCL information, a second rate matching configuration, or a combination thereof, is applied to the shared one or more DMRS ports using a frequency resource allocation and time resource allocation associated with the second DMRS port group.

[0312] The multi-stage DCI manager 1555 may transmit the second DCI message that includes an indication of a second DMRS port group-specific parameter set. In some examples, the multi-stage DCI manager 1555 may configure, based on one or more bits or fields in the DCI message that explicitly indicate the resource for the second DCI message, a resource occupancy for the second DCI message. In some examples, the multi-stage DCI manager 1555 may receive a signal indicating that at least the second DCI message or at least one DMRS port of the second DMRS port group associated with different portions of a TB of a CW could not be decoded. In some examples, the multi-stage DCI manager 1555 may perform, based on the signal and the transmission scheme, a retransmission of the second DCI message or the different portion of the TB.

[0313] In some examples, the multi-stage DCI manager 1555 may receive a first signal indicating a decoding result of a TB associated with the first DMRS port group. In some examples, the multi-stage DCI manager 1555 may receive a second signal indicating that at least the second DCI message or a TB associated with the second DMRS port group could not be decoded. In some examples, the multi-stage DCI manager 1555 may perform, based on the second signal and the transmission scheme, a retransmission of the second DCI message or the TB associated with the second DMRS port group. In some examples, the multi-stage DCI manager 1555 may receive a first signal indicating a decoding result of the

TB. In some examples, the multi-stage DCI manager 1555 may receive a second signal indicating that the second DCI message could not be decoded. In some examples, the multi-stage DCI manager 1555 may perform a retransmission of the second DCI message. In some cases, the indication of the resource includes an indication of a starting resource block for receiving the second DCI message.

[0314] In some cases, the indication of the resource includes an indication of a component carrier identifier or a cell identifier, where the component carrier identifier or the cell identifier conveys an indication of a starting resource block for receiving the second DCI message. In some cases, the indication of the resource includes an indicator indicating whether a resource allocation for the second DMRS port group is the same as the resource allocation for the first DMRS port group. In some cases, the mode indicator indicated in the DCI message conveys an indication of whether a resource allocation for the second DMRS port group is the same as a resource allocation for the first DMRS port group.

[0315] FIG. 16 shows a diagram of a system 1600 including a device 1605 that supports single and multi-stage DCI design for multiple transceiver nodes in accordance with aspects of the present disclosure. The device 1605 may be an example of or include the components of device 1305, device 1405, or a base station 105 as described herein. The device 1605 may include components for bi-directional voice and data communications including components for transmitting and receiving communications, including a communications manager 1610, a network communications manager 1615, a transceiver 1620, an antenna 1625, memory 1630, a processor 1640, and an inter-station communications manager 1645. These components may be in electronic communication via one or more buses (e.g., bus 1650).

[0316] The communications manager 1610 may determine that a downlink transmission to a UE is to occur, the downlink transmission including one or more CWs associated with one or more DMRS port groups, configure a DCI message to indicate a mode indicator, a common parameter set for the one or more DMRS port groups, and one or more DMRS port group-specific parameter set, where the mode indicator provides an indication of the association between the one or more DMRS port groups and the one or more CWs being communicated during the downlink transmission, and transmit the DCI message to configure the downlink transmission.

[0317] The network communications manager 1615 may manage communications with the core network (e.g., via one or more wired backhaul links). For example, the network communications manager 1615 may manage the transfer of data communications for client devices, such as one or more UEs 115.

5 [0318] The transceiver 1620 may communicate bi-directionally, via one or more antennas, wired, or wireless links as described above. For example, the transceiver 1620 may represent a wireless transceiver and may communicate bi-directionally with another wireless transceiver. The transceiver 1620 may also include a modem to modulate the packets and provide the modulated packets to the antennas for transmission, and to demodulate packets
10 received from the antennas.

[0319] In some cases, the wireless device may include a single antenna 1625. However, in some cases the device may have more than one antenna 1625, which may be capable of concurrently transmitting or receiving multiple wireless transmissions.

[0320] The memory 1630 may include RAM, ROM, or a combination thereof. The
15 memory 1630 may store computer-readable code 1635 including instructions that, when executed by a processor (e.g., the processor 1640) cause the device to perform various functions described herein. In some cases, the memory 1630 may contain, among other things, a BIOS which may control basic hardware or software operation such as the interaction with peripheral components or devices.

20 [0321] The processor 1640 may include an intelligent hardware device, (e.g., a general-purpose processor, a DSP, a CPU, a microcontroller, an ASIC, an FPGA, a programmable logic device, a discrete gate or transistor logic component, a discrete hardware component, or any combination thereof). In some cases, the processor 1640 may be configured to operate a memory array using a memory controller. In some cases, a memory controller may be
25 integrated into processor 1640. The processor 1640 may be configured to execute computer-readable instructions stored in a memory (e.g., the memory 1630) to cause the device
#{device} to perform various functions (e.g., functions or tasks supporting single and multi-stage DCI design for multiple transceiver nodes).

[0322] The inter-station communications manager 1645 may manage communications
30 with other base station 105, and may include a controller or scheduler for controlling communications with UEs 115 in cooperation with other base stations 105. For example, the

inter-station communications manager 1645 may coordinate scheduling for transmissions to UEs 115 for various interference mitigation techniques such as beamforming or joint transmission. In some examples, the inter-station communications manager 1645 may provide an X2 interface within an LTE/LTE-A wireless communication network technology to provide communication between base stations 105.

[0323] The code 1635 may include instructions to implement aspects of the present disclosure, including instructions to support wireless communications. The code 1635 may be stored in a non-transitory computer-readable medium such as system memory or other type of memory. In some cases, the code 1635 may not be directly executable by the processor 1640 but may cause a computer (e.g., when compiled and executed) to perform functions described herein.

[0324] FIG. 17 shows a flowchart illustrating a method 1700 that supports single and multi-stage DCI design for multiple transceiver nodes in accordance with aspects of the present disclosure. The operations of method 1700 may be implemented by a UE 115 or its components as described herein. For example, the operations of method 1700 may be performed by a communications manager as described with reference to FIGs. 9 through 12. In some examples, a UE may execute a set of instructions to control the functional elements of the UE to perform the functions described below. Additionally or alternatively, a UE may perform aspects of the functions described below using special-purpose hardware.

[0325] At 1705, the UE may receive a DCI message configuring a downlink transmission of one or more CWs associated with one or more DMRS port groups, where the DCI message includes a mode indicator, a common parameter set for the one or more DMRS port groups, and one or more DMRS port group-specific parameter set. The operations of 1705 may be performed according to the methods described herein. In some examples, aspects of the operations of 1705 may be performed by a DCI manager as described with reference to FIGs. 9 through 12.

[0326] At 1710, the UE may determine, based on the mode indicator, a transmission scheme for the downlink transmission, where the transmission scheme includes an association between the one or more DMRS port groups and the one or more CWs. The operations of 1710 may be performed according to the methods described herein. In some

examples, aspects of the operations of 1710 may be performed by a mode indicator as described with reference to FIGs. 9 through 12.

[0327] At 1715, the UE may determine, based on at least one of the common parameter set for the one or more DMRS port groups, the one or more DMRS port group-specific parameter set, or a combination thereof, at least one of a QCL information, a rate matching configuration, a resource allocation, or a combination thereof, for at least one DMRS port group. The operations of 1715 may be performed according to the methods described herein. In some examples, aspects of the operations of 1715 may be performed by a transmission scheme manager as described with reference to FIGs. 9 through 12.

10 [0328] FIG. 18 shows a flowchart illustrating a method 1800 that supports single and multi-stage DCI design for multiple transceiver nodes in accordance with aspects of the present disclosure. The operations of method 1800 may be implemented by a base station 105 or its components as described herein. For example, the operations of method 1800 may be performed by a communications manager as described with reference to FIGs. 13 through 16. In some examples, a base station may execute a set of instructions to control the functional elements of the base station to perform the functions described below. Additionally or 15 alternatively, a base station may perform aspects of the functions described below using special-purpose hardware.

[0329] At 1805, the base station may determine that a downlink transmission to a UE is to occur, the downlink transmission including one or more CWs associated with one or more DMRS port groups. The operations of 1805 may be performed according to the methods described herein. In some examples, aspects of the operations of 1805 may be performed by a transmission scheme manager as described with reference to FIGs. 13 through 16. 20

[0330] At 1810, the base station may configure a DCI message to indicate a mode indicator, a common parameter set for the one or more DMRS port groups, and one or more DMRS port group-specific parameter set, where the mode indicator provides an indication of the association between the one or more DMRS port groups and the one or more CWs being communicated during the downlink transmission. The operations of 1810 may be performed according to the methods described herein. In some examples, aspects of the operations of 25 1810 may be performed by a DCI manager as described with reference to FIGs. 13 through 16. 30

[0331] At 1815, the base station may transmit the DCI message to configure the downlink transmission. The operations of 1815 may be performed according to the methods described herein. In some examples, aspects of the operations of 1815 may be performed by a downlink transmission manager as described with reference to FIGs. 13 through 16.

5 [0332] It should be noted that the methods described herein describe possible implementations, and that the operations and the steps may be rearranged or otherwise modified and that other implementations are possible. Further, aspects from two or more of the methods may be combined.

[0333] Techniques described herein may be used for various wireless communications
10 systems such as code division multiple access (CDMA), time division multiple access (TDMA), frequency division multiple access (FDMA), orthogonal frequency division multiple access (OFDMA), single carrier frequency division multiple access (SC-FDMA), and other systems. A CDMA system may implement a radio technology such as CDMA2000, Universal Terrestrial Radio Access (UTRA), etc. CDMA2000 covers IS-2000, IS-95, and IS-
15 856 standards. IS-2000 Releases may be commonly referred to as CDMA2000 1X, 1X, etc. IS-856 (TIA-856) is commonly referred to as CDMA2000 1xEV-DO, High Rate Packet Data (HRPD), etc. UTRA includes Wideband CDMA (WCDMA) and other variants of CDMA. A TDMA system may implement a radio technology such as Global System for Mobile Communications (GSM).

20 [0334] An OFDMA system may implement a radio technology such as Ultra Mobile Broadband (UMB), Evolved UTRA (E-UTRA), Institute of Electrical and Electronics Engineers (IEEE) 802.11 (Wi-Fi), IEEE 802.16 (WiMAX), IEEE 802.20, Flash-OFDM, etc. UTRA and E-UTRA are part of Universal Mobile Telecommunications System (UMTS). LTE, LTE-A, and LTE-A Pro are releases of UMTS that use E-UTRA. UTRA, E-UTRA,
25 UMTS, LTE, LTE-A, LTE-A Pro, NR, and GSM are described in documents from the organization named "3rd Generation Partnership Project" (3GPP). CDMA2000 and UMB are described in documents from an organization named "3rd Generation Partnership Project 2" (3GPP2). The techniques described herein may be used for the systems and radio technologies mentioned herein as well as other systems and radio technologies. While aspects
30 of an LTE, LTE-A, LTE-A Pro, or NR system may be described for purposes of example, and LTE, LTE-A, LTE-A Pro, or NR terminology may be used in much of the description,

the techniques described herein are applicable beyond LTE, LTE-A, LTE-A Pro, or NR applications.

[0335] A macro cell generally covers a relatively large geographic area (e.g., several kilometers in radius) and may allow unrestricted access by UEs 115 with service subscriptions with the network provider. A small cell may be associated with a lower-powered base station 105, as compared with a macro cell, and a small cell may operate in the same or different (e.g., licensed, unlicensed, etc.) frequency bands as macro cells. Small cells may include pico cells, femto cells, and micro cells according to various examples. A pico cell, for example, may cover a small geographic area and may allow unrestricted access by UEs 115 with service subscriptions with the network provider. A femto cell may also cover a small geographic area (e.g., a home) and may provide restricted access by UEs 115 having an association with the femto cell (e.g., UEs 115 in a closed subscriber group (CSG), UEs 115 for users in the home, and the like). An eNB for a macro cell may be referred to as a macro eNB. An eNB for a small cell may be referred to as a small cell eNB, a pico eNB, a femto eNB, or a home eNB. An eNB may support one or multiple (e.g., two, three, four, and the like) cells, and may also support communications using one or multiple component carriers.

[0336] The wireless communications system 100 or systems described herein may support synchronous or asynchronous operation. For synchronous operation, the base stations 105 may have similar frame timing, and transmissions from different base stations 105 may be approximately aligned in time. For asynchronous operation, the base stations 105 may have different frame timing, and transmissions from different base stations 105 may not be aligned in time. The techniques described herein may be used for either synchronous or asynchronous operations.

[0337] Information and signals described herein may be represented using any of a variety of different technologies and techniques. For example, data, instructions, commands, information, signals, bits, symbols, and chips that may be referenced throughout the description may be represented by voltages, currents, electromagnetic waves, magnetic fields or particles, optical fields or particles, or any combination thereof.

[0338] The various illustrative blocks and modules described in connection with the disclosure herein may be implemented or performed with a general-purpose processor, a digital signal processor (DSP), an application-specific integrated circuit (ASIC), a field-

programmable gate array (FPGA) or other programmable logic device (PLD), discrete gate or transistor logic, discrete hardware components, or any combination thereof designed to perform the functions described herein. A general-purpose processor may be a microprocessor, but in the alternative, the processor may be any conventional processor, controller, microcontroller, or state machine. A processor may also be implemented as a combination of computing devices (e.g., a combination of a DSP and a microprocessor, multiple microprocessors, one or more microprocessors in conjunction with a DSP core, or any other such configuration).

[0339] The functions described herein may be implemented in hardware, software executed by a processor, firmware, or any combination thereof. If implemented in software executed by a processor, the functions may be stored on or transmitted over as one or more instructions or code on a computer-readable medium. Other examples and implementations are within the scope of the disclosure and appended claims. For example, due to the nature of software, functions described herein can be implemented using software executed by a processor, hardware, firmware, hardwiring, or combinations of any of these. Features implementing functions may also be physically located at various positions, including being distributed such that portions of functions are implemented at different physical locations.

[0340] Computer-readable media includes both non-transitory computer storage media and communication media including any medium that facilitates transfer of a computer program from one place to another. A non-transitory storage medium may be any available medium that can be accessed by a general purpose or special purpose computer. By way of example, and not limitation, non-transitory computer-readable media may include random-access memory (RAM), read-only memory (ROM), electrically erasable programmable read only memory (EEPROM), flash memory, compact disk (CD) ROM or other optical disk storage, magnetic disk storage or other magnetic storage devices, or any other non-transitory medium that can be used to carry or store desired program code means in the form of instructions or data structures and that can be accessed by a general-purpose or special-purpose computer, or a general-purpose or special-purpose processor. Also, any connection is properly termed a computer-readable medium. For example, if the software is transmitted from a website, server, or other remote source using a coaxial cable, fiber optic cable, twisted pair, digital subscriber line (DSL), or wireless technologies such as infrared, radio, and microwave, then the coaxial cable, fiber optic cable, twisted pair, DSL, or wireless

technologies such as infrared, radio, and microwave are included in the definition of medium. Disk and disc, as used herein, include CD, laser disc, optical disc, digital versatile disc (DVD), floppy disk and Blu-ray disc where disks usually reproduce data magnetically, while discs reproduce data optically with lasers. Combinations of the above are also included within the scope of computer-readable media.

[0341] As used herein, including in the claims, “or” as used in a list of items (e.g., a list of items prefaced by a phrase such as “at least one of” or “one or more of”) indicates an inclusive list such that, for example, a list of at least one of A, B, or C means A or B or C or AB or AC or BC or ABC (i.e., A and B and C). Also, as used herein, the phrase “based on” shall not be construed as a reference to a closed set of conditions. For example, an exemplary step that is described as “based on condition A” may be based on both a condition A and a condition B without departing from the scope of the present disclosure. In other words, as used herein, the phrase “based on” shall be construed in the same manner as the phrase “based at least in part on.”

[0342] In the appended figures, similar components or features may have the same reference label. Further, various components of the same type may be distinguished by following the reference label by a dash and a second label that distinguishes among the similar components. If just the first reference label is used in the specification, the description is applicable to any one of the similar components having the same first reference label irrespective of the second reference label, or other subsequent reference label.

[0343] The description set forth herein, in connection with the appended drawings, describes example configurations and does not represent all the examples that may be implemented or that are within the scope of the claims. The term “exemplary” used herein means “serving as an example, instance, or illustration,” and not “preferred” or “advantageous over other examples.” The detailed description includes specific details for the purpose of providing an understanding of the described techniques. These techniques, however, may be practiced without these specific details. In some instances, well-known structures and devices are shown in block diagram form in order to avoid obscuring the concepts of the described examples.

[0344] The description herein is provided to enable a person skilled in the art to make or use the disclosure. Various modifications to the disclosure will be readily apparent to those

skilled in the art, and the generic principles defined herein may be applied to other variations without departing from the scope of the disclosure. Thus, the disclosure is not limited to the examples and designs described herein, but is to be accorded the broadest scope consistent with the principles and novel features disclosed herein.

CLAIMS

What is claimed is:

- 1 1. A method for wireless communication at a user equipment (UE),
2 comprising:
3 receiving a downlink control information (DCI) message configuring a
4 downlink transmission of one or more codewords (CWs) associated with one or more
5 demodulation reference signal (DMRS) port groups, wherein the DCI message comprises a
6 mode indicator, a common parameter set for the one or more DMRS port groups, and one or
7 more DMRS port group-specific parameter set;
8 determining, based at least in part on the mode indicator, a transmission
9 scheme for the downlink transmission, wherein the transmission scheme comprises an
10 association between the one or more DMRS port groups and the one or more CWs; and
11 determining, based at least in part on at least one of the common parameter set
12 for the one or more DMRS port groups, the one or more DMRS port group-specific
13 parameter set, or a combination thereof, at least one of quasi-co-located (QCL) information, a
14 rate matching configuration, a resource allocation, or a combination thereof, for at least one
15 DMRS port group.
- 1 2. The method of claim 1, further comprising:
2 determining, based at least in part on a first DMRS port group-specific
3 parameter set, at least one of a first QCL information, a first rate matching configuration, a
4 first resource allocation, or a combination thereof, for a first DMRS port group; and
5 determining, based at least in part on a second DMRS port group-specific
6 parameter set, at least one of a second QCL information, a second rate matching
7 configuration, a second resource allocation, or a combination thereof, for a second DMRS
8 port group.
- 1 3. The method of claim 1, wherein each of the one or more DMRS port
2 group-specific parameter set comprises an indication of at least one of a frequency domain
3 resource allocation, a time domain resource allocation, the QCL information, the rate
4 matching configuration, or combinations thereof, for an associated DMRS port group.

1 4. The method of claim 3, further comprising:
2 identifying one or more DCI message formats based at least in part on the one
3 or more DMRS port group-specific parameter sets; and
4 determining the DCI message format for the DCI message based at least in
5 part on at least one of a cyclic redundancy check (CRC) scrambling sequence associated with
6 each of the one or more DCI message formats, a payload size of each of the one or more DCI
7 message formats, or a combination thereof.

1 5. The method of claim 1, wherein the common parameter set comprises
2 an indication of at least one of a CW configuration for each CW being communicated during
3 the downlink transmission, a hybrid automatic repeat/request (HARQ) process number, a
4 HARQ timing parameter, a downlink assignment index, a frequency resource allocation
5 common to each DMRS port group, a time resource allocation common to each DMRS port
6 group, a DMRS port grouping, or a combination thereof.

1 6. The method of claim 1, further comprising:
2 identifying a scrambling sequence used to scramble the DCI message, wherein
3 the scrambling sequence comprises the mode indicator.

1 7. The method of claim 1, wherein the DCI message comprises one or
2 more bits or fields configured to indicate the mode indicator.

1 8. The method of claim 1, further comprising:
2 receiving a signal indicating a set of supported transmission schemes; and
3 identifying the transmission scheme from the set of supported transmission
4 schemes based at least in part on the mode indicator.

1 9. The method of claim 1, wherein the transmission scheme comprises a
2 first transport block (TB) associated with a first CW being communicated using a first DMRS
3 port group and a second TB associated with a second CW being communicated using a
4 second DMRS port group.

1 10. The method of claim 9, wherein:
2 a first data stream associated with the first TB that is associated with the first
3 CW is mapped to the first DMRS port group according to an order comprising a first layer of

4 the first DMRS port group, then a frequency resource allocation of the first DMRS port group,
5 and then a time resource allocation of the first DMRS port group; and

6 a second data stream associated with the second TB that is associated with the
7 second CW is mapped to the second DMRS port group according to an order comprising a
8 second layer of the second DMRS port group, then a frequency resource allocation of the
9 second DMRS port group, and then a time resource allocation of the second DMRS port
10 group.

1 11. The method of claim 1, wherein the transmission scheme comprises a
2 transport block (TB) associated with a first CW being communicated using a first DMRS port
3 group and a second DMRS port group, wherein a first version of the CW is communicated
4 from the first DMRS port group and a second version of the CW is communicated from the
5 second DMRS port group.

1 12. The method of claim 11, wherein the first and second versions of the
2 CW comprise a different redundancy version or a different mapping function between the TB
3 and the DMRS port group.

1 13. The method of claim 11, wherein:
2 a first data stream associated with a first version of the TB that is associated
3 with the CW is mapped to the first DMRS port group according to an order comprising a first
4 layer of the first DMRS port group, then a frequency resource allocation of the first DMRS
5 port group, and then a time resource allocation of the first DMRS port group; and
6 a second data stream associated with a second version of the TB that is
7 associated with the CW is mapped to the second DMRS port group according to an order
8 comprising a second layer of the second DMRS port group, then a frequency resource
9 allocation of the second DMRS port group, and then a time resource allocation of the second
10 DMRS port group.

1 14. The method of claim 1, wherein the transmission scheme comprises a
2 transport block (TB) associated with a first CW being communicated using a first DMRS port
3 group and a second DMRS port group, wherein a first portion of the CW is communicated
4 from the first DMRS port group and a second portion of the CW is communicated from the
5 second DMRS port group.

1 15. The method of claim 14, wherein:
2 a first data stream associated with a first portion of the TB that is associated
3 with the CW is mapped to the first DMRS port group according to an order comprising a first
4 layer of the first DMRS port group, then a frequency resource allocation of the first DMRS
5 port group, and then a time resource allocation of the first DMRS port group; and
6 a second data stream associated with a second portion of the TB that is
7 associated with the CW is mapped to the second DMRS port group according to an order
8 comprising a second layer of the second DMRS port group, then a frequency resource
9 allocation of the second DMRS port group, and then a time resource allocation of the second
10 DMRS port group.

1 16. The method of claim 14, further comprising:
2 aggregating, based at least in part on an index associated with each DMRS
3 port of the first DMRS port group and the second DMRS port group, the DMRS port of the
4 first DMRS port group and the second DMRS port group to form an aggregated DMRS port;
5 aggregating, based at least in part on an index associated with each resource
6 element associated with a frequency resource allocation and a time resource allocation
7 associated with the first DMRS port group and second DMRS port group, a frequency
8 resource allocation and a time resource allocation associated with the first DMRS port group
9 and the second DMRS port group to form an aggregated frequency resource allocation and an
10 aggregated time resource allocation; and
11 mapping a data stream of the TB associated with the CW according to the
12 order comprising one or more layers associated with the aggregated DMRS port, then the
13 aggregated frequency resource allocation, and then the aggregated time resource allocation.

1 17. The method of claim 1, further comprising:
2 determining that a first DMRS port group and a second DMRS port group are
3 configured with a same frequency resource allocation and time resource allocation; and
4 determining that the first DMRS port group and the second DMRS port group
5 are configured with different DMRS ports.

1 18. The method of claim 1, further comprising:

2 determining that a first DMRS port group and a second DMRS port group are
3 configured with a different frequency resource allocation and time resource allocation;

4 determining that the first DMRS port group is active in the frequency resource
5 allocation and time resource allocation associated with the first DMRS port group; and

6 determining that the second DMRS port group is active in the frequency
7 resource allocation and time resource allocation associated with the second DMRS port group.

1 19. The method of claim 1, further comprising:

2 determining that a first DMRS port group and a second DMRS port group
3 share one or more DMRS ports, but are configured with a different frequency resource
4 allocation and time resource allocation;

5 determining that at least one of a first QCL information, a first rate matching
6 configuration, or a combination thereof, is applied to the shared one or more DMRS ports
7 using a frequency resource allocation and time resource allocation associated with the first
8 DMRS port group; and

9 determining that at least one of a second QCL information, a second rate
10 matching configuration, or a combination thereof, is applied to the shared one or more DMRS
11 ports using a frequency resource allocation and time resource allocation associated with the
12 second DMRS port group.

1 20. The method of claim 1, wherein the DCI message comprises the
2 common parameter set for the one or more DMRS port groups, a first DMRS port group-
3 specific parameter set, and an indication of a resource for receiving a second DCI message,
4 further comprising:

5 receiving the second DCI message that comprises an indication of a second
6 DMRS port group-specific parameter set.

1 21. The method of claim 20, wherein the indication of the resource
2 comprises an indication of a starting resource block for receiving the second DCI message.

1 22. The method of claim 21, further comprising:

2 determining, based at least in part on the starting resource block for the second
3 DCI message, a payload size for the second DCI message;

4 determining, based at least in part on the payload size, whether the resource
5 allocation for the first DMRS port group is the same as or different from the resource
6 allocation for the second DMRS port group;

7 determining, upon a determination that the resource allocation for the first
8 DMRS port group is the same as the resource allocation for the second DMRS port group,
9 that the second DMRS port group-specific parameter set does not indicate the resource
10 allocation for the second DMRS port group; and

11 determining, upon a determination that the resource allocation for the first
12 DMRS port group is different from the resource allocation for the second DMRS port group,
13 that the second DMRS port group-specific parameter set does indicate the resource allocation
14 for the second DMRS port group.

1 23. The method of claim 20, wherein the indication of the resource
2 comprises an indication of a component carrier identifier or a cell identifier, wherein the
3 component carrier identifier or the cell identifier conveys an indication of a starting resource
4 block for receiving the second DCI message.

1 24. The method of claim 23, further comprising:
2 determining, based at least in part on the starting resource block for the second
3 DCI message, a payload size for the second DCI message;

4 determining, based at least in part on the payload size, whether the resource
5 allocation for the first DMRS port group is the same as or different from the resource
6 allocation for the second DMRS port group;

7 determining, upon a determination that the resource allocation for the first
8 DMRS port group is the same as the resource allocation for the second DMRS port group,
9 that the second DMRS port group-specific parameter set does not indicate the resource
10 allocation for the second DMRS port group; and

11 determining, upon a determination that the resource allocation for the first
12 DMRS port group is different from the resource allocation for the second DMRS port group,
13 that the second DMRS port group-specific parameter set does indicate the resource allocation
14 for the second DMRS port group.

1 25. The method of claim 20, wherein the indication of the resource
2 comprises an indicator indicating whether a resource allocation for the second DMRS port

3 group is the same as the resource allocation for the first DMRS port group, further
4 comprising:
5 determining, based at least in part on an indicator, a payload size of the second
6 DCI message conveying the second DMRS port group-specific parameter set for the second
7 DMRS port group;
8 determining, based at least in part on the payload size, the resource allocation
9 for the second DCI message;
10 determining, upon a determination that the resource allocation for the first
11 DMRS port group is the same as the resource allocation for the second DMRS port group,
12 that the second DMRS port group-specific parameter set does not indicate the resource
13 allocation for the second DMRS port group; and
14 determining, upon a determination that the resource allocation for the first
15 DMRS port group is different from the resource allocation for the second DMRS port group,
16 that the second DMRS port group-specific parameter set does indicate the resource allocation
17 for the second DMRS port group.

1 26. The method of claim 20, wherein the mode indicator indicated in the
2 DCI message conveys an indication of whether a resource allocation for the second DMRS
3 port group is the same as a resource allocation for the first DMRS port group, further
4 comprising:
5 determining, based at least in part on the mode indicator, a payload size of the
6 second DCI message conveying the second DMRS port group-specific parameter set for the
7 second DMRS port group;
8 determining, based at least in part on the payload size, the resource allocation
9 for the second DCI message;
10 determining, upon a determination that the resource allocation for the first
11 DMRS port group is the same as the resource allocation for the second DMRS port group,
12 that the second DMRS port group-specific parameter set does not indicate the resource
13 allocation for the second DMRS port group; and
14 determining, upon a determination that the resource allocation for the first
15 DMRS port group is different from the resource allocation for the second DMRS port group,
16 that the second DMRS port group-specific parameter set does indicate the resource allocation
17 for the second DMRS port group.

1 27. The method of claim 20, further comprising:
2 determining, based at least in part on one or more bits or fields in the DCI
3 message that explicitly indicates the resource for the second DCI message, a resource
4 occupancy for the second DCI message;
5 determining, based at least in part on the resource occupancy, whether the
6 resource allocation for the first DMRS port group is the same as or different from the
7 resource allocation for the second DMRS port group;
8 determining, upon a determination that the resource allocation for the first
9 DMRS port group is the same as the resource allocation for the second DMRS port group,
10 that the second DMRS port group-specific parameter set does not indicate the resource
11 allocation for the second DMRS port group; and
12 determining, upon a determination that the resource allocation for the first
13 DMRS port group is different from the resource allocation for the second DMRS port group,
14 that the second DMRS port group-specific parameter set does indicate the resource allocation
15 for the second DMRS port group.

1 28. The method of claim 20, further comprising:
2 determining that the second DCI message could not be decoded;
3 determining, based at least in part on the transmission scheme, that the first
4 DMRS port group and at least one port of the second DMRS port group are associated with
5 different portions of a transport block (TB) of a CW; and
6 transmitting a signal indicating that at least the second DCI message or the TB
7 could not be decoded.

1 29. The method of claim 20, further comprising:
2 determining that the second DCI message could not be decoded;
3 determining, based at least in part on the transmission scheme, that the first
4 DMRS port group and at least one DMRS port of the second DMRS port group are associated
5 with different transport blocks (TBs); and
6 transmitting a first signal indicating a decoding result of the TB associated
7 with the first DMRS port group.

1 30. The method of claim 29, further comprising:

2 transmitting a second signal indicating that at least the second DCI message or
3 the TB associated with the second DMRS port group could not be decoded.

1 31. The method of claim 20, further comprising:
2 determining that the second DCI message could not be decoded;
3 determining, based at least in part on the transmission scheme, that the first
4 DMRS port group and at least one DMRS port of the second DMRS port group are associated
5 with different versions of a transport block (TB) associated with a CW; and
6 transmitting a first signal indicating a decoding result of the TB.

1 32. The method of claim 31, further comprising:
2 transmitting a second signal indicating that the second DCI message could not
3 be decoded.

1 33. A method for wireless communication at a base station, comprising:
2 determining that a downlink transmission to a user equipment (UE) is to occur,
3 the downlink transmission comprising one or more codewords (CWs) associated with one or
4 more demodulation reference signal (DMRS) port groups;
5 configuring a downlink control information (DCI) message to indicate a mode
6 indicator, a common parameter set for the one or more DMRS port groups, and one or more
7 DMRS port group-specific parameter set, wherein the mode indicator provides an indication
8 of the association between the one or more DMRS port groups and the one or more CWs
9 being communicated during the downlink transmission; and
10 transmitting the DCI message to configure the downlink transmission.

1 34. The method of claim 33, further comprising:
2 configuring a first DMRS port group-specific parameter set to indicate at least
3 one of a first QCL information, a first rate matching configuration, a first resource allocation,
4 or a combination thereof, for a first DMRS port group; and
5 configuring a second DMRS port group-specific parameter set to indicate at
6 least one of a second QCL information, a second rate matching configuration, a second
7 resource allocation, or a combination thereof, for a second DMRS port group.

1 35. The method of claim 33, wherein each of the one or more DMRS port
2 group-specific parameter set comprises an indication of at least one of a frequency domain

3 resource allocation, a time domain resource allocation, the QCL information, the rate
4 matching configuration, or combinations thereof, for an associated DMRS port group.

1 36. The method of claim 35, further comprising:
2 identifying one or more DCI message formats based at least in part on the one
3 or more DMRS port group-specific parameter sets;
4 selecting the DCI message format for the DCI message based at least in part
5 on at least one of the one or more DMRS port group-specific parameter sets or the common
6 parameter set for the one or more DMRS port groups; and
7 scrambling the DCI message using a cyclic redundancy check (CRC)
8 scrambling sequence associated with the selected DCI message format.

1 37. The method of claim 33, wherein the common parameter set comprises
2 an indication of at least one of a CW configuration for each CW being communicated during
3 the downlink transmission, a hybrid automatic repeat/request (HARQ) process number, a
4 HARQ timing parameter, a downlink assignment index, a frequency resource allocation
5 common to each DMRS port group, a time resource allocation common to each DMRS port
6 group, a DMRS port grouping, or a combination thereof.

1 38. The method of claim 33, further comprising:
2 identifying a scrambling sequence used to scramble the DCI message, wherein
3 the scrambling sequence indicates the mode indicator.

1 39. The method of claim 33, wherein the DCI message comprises one or
2 more bits or fields configured to indicate the mode indicator.

1 40. The method of claim 33, further comprising:
2 transmitting a signal indicating a set of supported transmission schemes;
3 determining a transmission scheme from the set of supported transmission
4 schemes; and
5 transmitting the DCI message conveying the mode indicator to indicate the
6 determined transmission scheme.

1 41. The method of claim 33, wherein the transmission scheme comprises a
2 first transport block (TB) associated with a first CW being communicated using a first DMRS

3 port group and a second TB associated with a second CW being communicated using a
4 second DMRS port group.

1 42. The method of claim 41, wherein:

2 a first data stream associated with the first TB that is associated with the first
3 CW is mapped to the first DMRS port group according to an order comprising a first layer of
4 the first DMRS port group, then a frequency resource allocation of the first DMRS port group,
5 and then a time resource allocation of the first DMRS port group; and

6 a second data stream associated with the second TB that is associated with the
7 second CW is mapped to the second DMRS port group according to an order comprising a
8 second layer of the second DMRS port group, then a frequency resource allocation of the
9 second DMRS port group, and then a time resource allocation of the second DMRS port
10 group.

1 43. The method of claim 33, wherein the transmission scheme comprises a
2 transport block (TB) associated with a first CW being communicated using a first DMRS port
3 group and a second DMRS port group, wherein a first version of the CW is communicated
4 from the first DMRS port group and a second version of the CW is communicated from the
5 second DMRS port group.

1 44. The method of claim 43, wherein the first and second versions of the
2 CW comprise a different redundancy version or a different mapping function between the TB
3 and the DMRS port group.

1 45. The method of claim 43, wherein:

2 a first data stream associated with a first version of the TB that is associated
3 with the CW is mapped to the first DMRS port group according to an order comprising a first
4 layer of the first DMRS port group, then a frequency resource allocation of the first DMRS
5 port group, and then a time resource allocation of the first DMRS port group; and

6 a second data stream associated with a second version of the TB that is
7 associated with the CW is mapped to the second DMRS port group according to an order
8 comprising a second layer of the second DMRS port group, then a frequency resource
9 allocation of the second DMRS port group, and then a time resource allocation of the second
10 DMRS port group.

1 46. The method of claim 33, wherein the transmission scheme comprises a
2 transport block (TB) associated with a first CW being communicated using a first DMRS port
3 group and a second DMRS port group, wherein a first portion of the CW is communicated
4 from the first DMRS port group and a second portion of the CW is communicated from the
5 second DMRS port group.

1 47. The method of claim 46, wherein:
2 a first data stream associated with a first portion of the TB that is associated
3 with the CW is mapped to the first DMRS port group according to an order comprising a first
4 layer of the first DMRS port group, then a frequency resource allocation of the first DMRS
5 port group, and then a time resource allocation of the first DMRS port group; and
6 a second data stream associated with a second portion of the TB that is
7 associated with the CW is mapped to the second DMRS port group according to an order
8 comprising a second layer of the second DMRS port group, then a frequency resource
9 allocation of the second DMRS port group, and then a time resource allocation of the second
10 DMRS port group.

1 48. The method of claim 46, further comprising:
2 aggregating, based at least in part on an index associated with each DMRS
3 port of the first DMRS port group and the second DMRS port group, the DMRS port of the
4 first DMRS port group and the second DMRS port group to form an aggregated DMRS port;
5 aggregating, based at least in part on an index associated with each resource
6 element associated with a frequency resource allocation and a time resource allocation, the
7 frequency resource allocation and the time resource allocation to form an aggregated
8 frequency resource allocation and an aggregated time resource allocation; and
9 mapping a data stream of the TB associated with the CW according to the
10 order comprising one or more layers associated with the aggregated DMRS port, then the
11 aggregated frequency resource allocation, and then the aggregated time resource allocation.

1 49. The method of claim 33, further comprising:
2 configuring a first DMRS port group and a second DMRS port group with a
3 same frequency resource allocation and time resource allocation; and

4 configuring the first DMRS port group and the second DMRS port group with
5 different DMRS ports.

1 50. The method of claim 33, further comprising:
2 configuring a first DMRS port group and a second DMRS port group with a
3 different frequency resource allocation and time resource allocation, wherein the first DMRS
4 port group is active in the frequency resource allocation and time resource allocation
5 associated with the first DMRS port group and the second DMRS port group is active in the
6 frequency resource allocation and time resource allocation associated with the second DMRS
7 port group.

1 51. The method of claim 33, further comprising:
2 configuring a first DMRS port group and a second DMRS port group to share
3 one or more DMRS ports, but with a different frequency resource allocation and time
4 resource allocation;
5 wherein at least one of a first QCL information, a first rate matching
6 configuration, or a combination thereof, is applied to the shared one or more DMRS ports
7 using a frequency resource allocation and time resource allocation associated with the first
8 DMRS port group; and
9 wherein at least one of a second QCL information, a second rate matching
10 configuration, or a combination thereof, is applied to the shared one or more DMRS ports
11 using a frequency resource allocation and time resource allocation associated with the second
12 DMRS port group.

1 52. The method of claim 33, wherein the DCI message comprises the
2 common parameter set for the one or more DMRS port groups, a first DMRS port group-
3 specific parameter set, and an indication of a resource for receiving a second DCI message,
4 further comprising:
5 transmitting the second DCI message that comprises an indication of a second
6 DMRS port group-specific parameter set.

1 53. The method of claim 52, wherein the indication of the resource
2 comprises an indication of a starting resource block for receiving the second DCI message.

1 54. The method of claim 52, wherein the indication of the resource
2 comprises an indication of a component carrier identifier or a cell identifier, wherein the
3 component carrier identifier or the cell identifier conveys an indication of a starting resource
4 block for receiving the second DCI message.

1 55. The method of claim 52, wherein the indication of the resource
2 comprises an indicator indicating whether a resource allocation for the second DMRS port
3 group is the same as the resource allocation for the first DMRS port group.

1 56. The method of claim 52, wherein the mode indicator indicated in the
2 DCI message conveys an indication of whether a resource allocation for the second DMRS
3 port group is the same as a resource allocation for the first DMRS port group.

1 57. The method of claim 52, further comprising:
2 configuring, based at least in part on one or more bits or fields in the DCI
3 message that explicitly indicate the resource for the second DCI message, a resource
4 occupancy for the second DCI message.

1 58. The method of claim 52, further comprising:
2 receiving a signal indicating that at least the second DCI message or at least
3 one DMRS port of the second DMRS port group associated with different portions of a
4 transport block (TB) of a CW could not be decoded; and
5 performing, based at least in part on the signal and the transmission scheme, a
6 retransmission of the second DCI message or the different portion of the TB.

1 59. The method of claim 52, wherein, based at least in part on the
2 transmission scheme, that the first DMRS port group and at least one DMRS port of the
3 second DMRS port group are associated with different transport blocks (TBs), further
4 comprising:
5 receiving a first signal indicating a decoding result of a TB associated with the
6 first DMRS port group.

1 60. The method of claim 59, further comprising.
2 receiving a second signal indicating that at least the second DCI message or a
3 TB associated with the second DMRS port group could not be decoded; and

4 performing, based at least in part on the second signal and the transmission
5 scheme, a retransmission of the second DCI message or the TB associated with the second
6 DMRS port group.

1 61. The method of claim 52, wherein the first DMRS port group and at
2 least one DMRS port of the second DMRS port group are associated with different versions
3 of a transport block (TB), further comprising:

4 receiving a first signal indicating a decoding result of the TB.

1 62. The method of claim 61, further comprising:

2 receiving a second signal indicating that the second DCI message could not be
3 decoded; and

4 performing a retransmission of the second DCI message.

1 63. An apparatus for wireless communication at a user equipment (UE),
2 comprising:

3 a processor,

4 memory in electronic communication with the processor; and

5 instructions stored in the memory and executable by the processor to cause the
6 apparatus to:

7 receive a downlink control information (DCI) message configuring a
8 downlink transmission of one or more codewords (CWs) associated with one or more
9 demodulation reference signal (DMRS) port groups, wherein the DCI message
10 comprises a mode indicator, a common parameter set for the one or more DMRS port
11 groups, and one or more DMRS port group-specific parameter set;

12 determine, based at least in part on the mode indicator, a transmission
13 scheme for the downlink transmission, wherein the transmission scheme comprises an
14 association between the one or more DMRS port groups and the one or more CWs;
15 and

16 determine, based at least in part on at least one of the common
17 parameter set for the one or more DMRS port groups, the one or more DMRS port
18 group-specific parameter set, or a combination thereof, at least one of a quasi-co-
19 located (QCL) information, a rate matching configuration, a resource allocation, or a
20 combination thereof, for at least one DMRS port group.

1 64. The apparatus of claim 63, wherein the instructions are further
2 executable by the processor to cause the apparatus to:

3 determine, based at least in part on a first DMRS port group-specific
4 parameter set, at least one of a first QCL information, a first rate matching configuration, a
5 first resource allocation, or a combination thereof, for a first DMRS port group; and

6 determine, based at least in part on a second DMRS port group-specific
7 parameter set, at least one of a second QCL information, a second rate matching
8 configuration, a second resource allocation, or a combination thereof, for a second DMRS
9 port group.

1 65. The apparatus of claim 63, wherein each of the one or more DMRS
2 port group-specific parameter set comprises an indication of at least one of a frequency
3 domain resource allocation, a time domain resource allocation, the QCL information, the rate
4 matching configuration, or combinations thereof, for an associated DMRS port group.

1 66. The apparatus of claim 65, wherein the instructions are further
2 executable by the processor to cause the apparatus to:

3 identify one or more DCI message formats based at least in part on the one or
4 more DMRS port group-specific parameter sets; and

5 determine the DCI message format for the DCI message based at least in part
6 on at least one of a cyclic redundancy check (CRC) scrambling sequence associated with
7 each of the one or more DCI message formats, a payload size of each of the one or more DCI
8 message formats, or a combination thereof.

1 67. The apparatus of claim 63, wherein the common parameter set
2 comprises an indication of at least one of a CW configuration for each CW being
3 communicated during the downlink transmission, a hybrid automatic repeat/request (HARQ)
4 process number, a HARQ timing parameter, a downlink assignment index, a frequency
5 resource allocation common to each DMRS port group, a time resource allocation common to
6 each DMRS port group, a DMRS port grouping, or a combination thereof.

1 68. The apparatus of claim 63, wherein the instructions are further
2 executable by the processor to cause the apparatus to:

3 identify a scrambling sequence used to scramble the DCI message, wherein
4 the scrambling sequence comprises the mode indicator.

1 69. The apparatus of claim 63, wherein the DCI message comprises one or
2 more bits or fields configured to indicate the mode indicator.

1 70. The apparatus of claim 63, wherein the instructions are further
2 executable by the processor to cause the apparatus to:
3 receive a signal indicating a set of supported transmission schemes; and
4 identify the transmission scheme from the set of supported transmission
5 schemes based at least in part on the mode indicator.

1 71. The apparatus of claim 63, wherein the transmission scheme comprises
2 a first transport block (TB) associated with a first CW being communicated using a first
3 DMRS port group and a second TB associated with a second CW being communicated using
4 a second DMRS port group.

1 72. The apparatus of claim 71, wherein:
2 a first data stream associated with the first TB that is associated with the first
3 CW is mapped to the first DMRS port group according to an order comprising a first layer of
4 the first DMRS port group, then a frequency resource allocation of the first DMRS port group,
5 and then a time resource allocation of the first DMRS port group; and
6 a second data stream associated with the second TB that is associated with the
7 second CW is mapped to the second DMRS port group according to an order comprising a
8 second layer of the second DMRS port group, then a frequency resource allocation of the
9 second DMRS port group, and then a time resource allocation of the second DMRS port
10 group.

1 73. The apparatus of claim 63, wherein the transmission scheme comprises
2 a transport block (TB) associated with a first CW being communicated using a first DMRS
3 port group and a second DMRS port group, wherein a first version of the CW is
4 communicated from the first DMRS port group and a second version of the CW is
5 communicated from the second DMRS port group.

1 74. The apparatus of claim 73, wherein the first and second versions of the
2 CW comprise a different redundancy version or a different mapping function between the TB
3 and the DMRS port group.

1 75. The apparatus of claim 73, wherein:
2 a first data stream associated with a first version of the TB that is associated
3 with the CW is mapped to the first DMRS port group according to an order comprising a first
4 layer of the first DMRS port group, then a frequency resource allocation of the first DMRS
5 port group, and then a time resource allocation of the first DMRS port group; and
6 a second data stream associated with a second version of the TB that is
7 associated with the CW is mapped to the second DMRS port group according to an order
8 comprising a second layer of the second DMRS port group, then a frequency resource
9 allocation of the second DMRS port group, and then a time resource allocation of the second
10 DMRS port group.

1 76. The apparatus of claim 63, wherein the transmission scheme comprises
2 a transport block (TB) associated with a first CW being communicated using a first DMRS
3 port group and a second DMRS port group, wherein a first portion of the CW is
4 communicated from the first DMRS port group and a second portion of the CW is
5 communicated from the second DMRS port group.

1 77. The apparatus of claim 76, wherein:
2 a first data stream associated with a first portion of the TB that is associated
3 with the CW is mapped to the first DMRS port group according to an order comprising a first
4 layer of the first DMRS port group, then a frequency resource allocation of the first DMRS
5 port group, and then a time resource allocation of the first DMRS port group; and
6 a second data stream associated with a second portion of the TB that is
7 associated with the CW is mapped to the second DMRS port group according to an order
8 comprising a second layer of the second DMRS port group, then a frequency resource
9 allocation of the second DMRS port group, and then a time resource allocation of the second
10 DMRS port group.

1 78. The apparatus of claim 76, wherein the instructions are further
2 executable by the processor to cause the apparatus to:

3 aggregate, based at least in part on an index associated with each DMRS port
4 of the first DMRS port group and the second DMRS port group, the DMRS port of the first
5 DMRS port group and the second DMRS port group to form an aggregated DMRS port;

6 aggregate, based at least in part on an index associated with each resource
7 element associated with a frequency resource allocation and a time resource allocation
8 associated with the first DMRS port group and second DMRS port group, a frequency
9 resource allocation and a time resource allocation associated with the first DMRS port group
10 and the second DMRS port group to form an aggregated frequency resource allocation and an
11 aggregated time resource allocation; and

12 map a data stream of the TB associated with the CW according to the order
13 comprising one or more layers associated with the aggregated DMRS port, then the
14 aggregated frequency resource allocation, and then the aggregated time resource allocation.

1 79. The apparatus of claim 63, wherein the instructions are further
2 executable by the processor to cause the apparatus to:

3 determine that a first DMRS port group and a second DMRS port group are
4 configured with a same frequency resource allocation and time resource allocation; and

5 determine that the first DMRS port group and the second DMRS port group
6 are configured with different DMRS ports.

1 80. The apparatus of claim 63, wherein the instructions are further
2 executable by the processor to cause the apparatus to:

3 determine that a first DMRS port group and a second DMRS port group are
4 configured with a different frequency resource allocation and time resource allocation;

5 determine that the first DMRS port group is active in the frequency resource
6 allocation and time resource allocation associated with the first DMRS port group; and

7 determine that the second DMRS port group is active in the frequency
8 resource allocation and time resource allocation associated with the second DMRS port group.

1 81. The apparatus of claim 63, wherein the instructions are further
2 executable by the processor to cause the apparatus to:

3 determine that a first DMRS port group and a second DMRS port group share
4 one or more DMRS ports, but are configured with a different frequency resource allocation
5 and time resource allocation;

6 determine that at least one of a first QCL information, a first rate matching
7 configuration, or a combination thereof, is applied to the shared one or more DMRS ports
8 using a frequency resource allocation and time resource allocation associated with the first
9 DMRS port group; and

10 determine that at least one of a second QCL information, a second rate
11 matching configuration, or a combination thereof, is applied to the shared one or more DMRS
12 ports using a frequency resource allocation and time resource allocation associated with the
13 second DMRS port group.

1 82. The apparatus of claim 63, wherein the DCI message comprises the
2 common parameter set for the one or more DMRS port groups, and the instructions are
3 further executable by the processor to cause the apparatus to:

4 receive the second DCI message that comprises an indication of a second
5 DMRS port group-specific parameter set.

1 83. The apparatus of claim 82, wherein the indication of the resource
2 comprises an indication of a starting resource block for receiving the second DCI message.

1 84. The apparatus of claim 83, wherein the instructions are further
2 executable by the processor to cause the apparatus to:

3 determine, based at least in part on the starting resource block for the second
4 DCI message, a payload size for the second DCI message;

5 determine, based at least in part on the payload size, whether the resource
6 allocation for the first DMRS port group is the same as or different from the resource
7 allocation for the second DMRS port group;

8 determine, upon a determination that the resource allocation for the first
9 DMRS port group is the same as the resource allocation for the second DMRS port group,
10 that the second DMRS port group-specific parameter set does not indicate the resource
11 allocation for the second DMRS port group; and

12 determine, upon a determination that the resource allocation for the first
13 DMRS port group is different from the resource allocation for the second DMRS port group,
14 that the second DMRS port group-specific parameter set does indicate the resource allocation
15 for the second DMRS port group.

1 85. The apparatus of claim 82, wherein the indication of the resource
2 comprises an indication of a component carrier identifier or a cell identifier, wherein the
3 component carrier identifier or the cell identifier conveys an indication of a starting resource
4 block for receiving the second DCI message.

1 86. The apparatus of claim 85, wherein the instructions are further
2 executable by the processor to cause the apparatus to:

3 determine, based at least in part on the starting resource block for the second
4 DCI message, a payload size for the second DCI message;

5 determine, based at least in part on the payload size, whether the resource
6 allocation for the first DMRS port group is the same as or different from the resource
7 allocation for the second DMRS port group;

8 determine, upon a determination that the resource allocation for the first
9 DMRS port group is the same as the resource allocation for the second DMRS port group,
10 that the second DMRS port group-specific parameter set does not indicate the resource
11 allocation for the second DMRS port group; and

12 determine, upon a determination that the resource allocation for the first
13 DMRS port group is different from the resource allocation for the second DMRS port group,
14 that the second DMRS port group-specific parameter set does indicate the resource allocation
15 for the second DMRS port group.

1 87. The apparatus of claim 82, wherein the indication of the resource
2 comprises an indicator indicating whether a resource allocation for the second DMRS port
3 group is the same as the resource allocation for the first DMRS port group, and the
4 instructions are further executable by the processor to cause the apparatus to:

5 determine, based at least in part on the mode indicator, a payload size of the
6 second DCI message conveying the second DMRS port group-specific parameter set for the
7 second DMRS port group;

8 determine, based at least in part on the payload size, the resource allocation for
9 the second DCI message;

10 determine, upon a determination that the resource allocation for the first
11 DMRS port group is the same as the resource allocation for the second DMRS port group,

12 that the second DMRS port group-specific parameter set does not indicate the resource
13 allocation for the second DMRS port group; and
14 determine, upon a determination that the resource allocation for the first
15 DMRS port group is different from the resource allocation for the second DMRS port group,
16 that the second DMRS port group-specific parameter set does indicate the resource allocation
17 for the second DMRS port group.

1 88. The apparatus of claim 82, wherein:
2 determine, based at least in part on the mode indicator, a payload size of the
3 second DCI message conveying the second DMRS port group-specific parameter set for the
4 second DMRS port group;
5 determine, based at least in part on the payload size, the resource allocation for
6 the second DCI message;
7 determine, upon a determination that the resource allocation for the first
8 DMRS port group is the same as the resource allocation for the second DMRS port group,
9 that the second DMRS port group-specific parameter set does not indicate the resource
10 allocation for the second DMRS port group; and
11 determine, upon a determination that the resource allocation for the first
12 DMRS port group is different from the resource allocation for the second DMRS port group,
13 that the second DMRS port group-specific parameter set does indicate the resource allocation
14 for the second DMRS port group.

1 89. The apparatus of claim 82, wherein the instructions are further
2 executable by the processor to cause the apparatus to:
3 determine, based at least in part on one or more bits or fields in the DCI
4 message that explicitly indicates the resource for the second DCI message, a resource
5 occupancy for the second DCI message;
6 determine, based at least in part on the resource occupancy, whether the
7 resource allocation for the first DMRS port group is the same as or different from the
8 resource allocation for the second DMRS port group;
9 determine, upon a determination that the resource allocation for the first
10 DMRS port group is the same as the resource allocation for the second DMRS port group,

11 that the second DMRS port group-specific parameter set does not indicate the resource
12 allocation for the second DMRS port group; and
13 determine, upon a determination that the resource allocation for the first
14 DMRS port group is different from the resource allocation for the second DMRS port group,
15 that the second DMRS port group-specific parameter set does indicate the resource allocation
16 for the second DMRS port group.

1 90. The apparatus of claim 82, wherein the instructions are further
2 executable by the processor to cause the apparatus to:
3 determine that the second DCI message could not be decoded;
4 determine, based at least in part on the transmission scheme, that the first
5 DMRS port group and at least one port of the second DMRS port group are associated with
6 different portions of a transport block (TB) of a CW; and
7 transmit a signal indicating that at least the second DCI message or the TB
8 could not be decoded.

1 91. The apparatus of claim 82, wherein the instructions are further
2 executable by the processor to cause the apparatus to:
3 determine that the second DCI message could not be decoded;
4 determine, based at least in part on the transmission scheme, that the first
5 DMRS port group and at least one DMRS port of the second DMRS port group are associated
6 with different transport blocks (TBs); and
7 transmit a first signal indicating a decoding result of the TB associated with
8 the first DMRS port group.

1 92. The apparatus of claim 91, wherein the instructions are further
2 executable by the processor to cause the apparatus to:
3 transmit a second signal indicating that at least the second DCI message or the
4 TB associated with the second DMRS port group could not be decoded.

1 93. The apparatus of claim 82, wherein the instructions are further
2 executable by the processor to cause the apparatus to:
3 determine that the second DCI message could not be decoded;

4 determine, based at least in part on the transmission scheme, that the first
5 DMRS port group and at least one DMRS port of the second DMRS port group are associated
6 with different versions of a transport block (TB) associated with a CW; and
7 transmit a first signal indicating a decoding result of the TB.

1 94. The apparatus of claim 93, wherein the instructions are further
2 executable by the processor to cause the apparatus to:
3 transmit a second signal indicating that the second DCI message could not be
4 decoded.

1 95. An apparatus for wireless communication at a base station, comprising:
2 a processor,
3 memory in electronic communication with the processor; and
4 instructions stored in the memory and executable by the processor to cause the
5 apparatus to:

6 determine that a downlink transmission to a user equipment (UE) is to
7 occur, the downlink transmission comprising one or more codewords (CWs)
8 associated with one or more demodulation reference signal (DMRS) port groups;
9 configure a downlink control information (DCI) message to indicate a
10 mode indicator, a common parameter set for the one or more DMRS port groups, and
11 one or more DMRS port group-specific parameter set, wherein the mode indicator
12 provides an indication of the association between the one or more DMRS port groups
13 and the one or more CWs being communicated during the downlink transmission; and
14 transmit the DCI message to configure the downlink transmission.

1 96. The apparatus of claim 95, wherein the instructions are further
2 executable by the processor to cause the apparatus to:
3 configure a first DMRS port group-specific parameter set to indicate at least
4 one of a first QCL information, a first rate matching configuration, a first resource allocation,
5 or a combination thereof, for a first DMRS port group; and
6 configure a second DMRS port group-specific parameter set to indicate at
7 least one of a second QCL information, a second rate matching configuration, a second
8 resource allocation, or a combination thereof, for a second DMRS port group.

1 97. The apparatus of claim 95, wherein each of the one or more DMRS
2 port group-specific parameter set comprises an indication of at least one of a frequency
3 domain resource allocation, a time domain resource allocation, the QCL information, the rate
4 matching configuration, or combinations thereof, for an associated DMRS port group.

1 98. The apparatus of claim 97, wherein the instructions are further
2 executable by the processor to cause the apparatus to:
3 identify one or more DCI message formats based at least in part on the one or
4 more DMRS port group-specific parameter sets;
5 select the DCI message format for the DCI message based at least in part on at
6 least one of the one or more DMRS port group-specific parameter sets or the common
7 parameter set for the one or more DMRS port groups; and
8 scramble the DCI message using a cyclic redundancy check (CRC) scrambling
9 sequence associated with the selected DCI message format.

1 99. The apparatus of claim 95, wherein the common parameter set
2 comprises an indication of at least one of a CW configuration for each CW being
3 communicated during the downlink transmission, a hybrid automatic repeat/request (HARQ)
4 process number, a HARQ timing parameter, a downlink assignment index, a frequency
5 resource allocation common to each DMRS port group, a time resource allocation common to
6 each DMRS port group, a DMRS port grouping, or a combination thereof.

1 100. The apparatus of claim 95, wherein the instructions are further
2 executable by the processor to cause the apparatus to:
3 identify a scrambling sequence used to scramble the DCI message, wherein
4 the scrambling sequence indicates the mode indicator.

1 101. The apparatus of claim 95, wherein the DCI message comprises one or
2 more bits or fields configured to indicate the mode indicator.

1 102. The apparatus of claim 95, wherein the instructions are further
2 executable by the processor to cause the apparatus to:
3 transmit a signal indicating a set of supported transmission schemes;

4 determine a transmission scheme from the set of supported transmission
5 schemes; and
6 transmit the DCI message conveying the mode indicator to indicate the
7 determined transmission scheme.

1 103. The apparatus of claim 95, wherein the transmission scheme comprises
2 a first transport block (TB) associated with a first CW being communicated using a first
3 DMRS port group and a second TB associated with a second CW being communicated using
4 a second DMRS port group.

1 104. The apparatus of claim 103, wherein:
2 a first data stream associated with the first TB that is associated with the first
3 CW is mapped to the first DMRS port group according to an order comprising a first layer of
4 the first DMRS port group, then a frequency resource allocation of the first DMRS port group,
5 and then a time resource allocation of the first DMRS port group; and

6 a second data stream associated with the second TB that is associated with the
7 second CW is mapped to the second DMRS port group according to an order comprising a
8 second layer of the second DMRS port group, then a frequency resource allocation of the
9 second DMRS port group, and then a time resource allocation of the second DMRS port
10 group.

1 105. The apparatus of claim 95, wherein the transmission scheme comprises
2 a transport block (TB) associated with a first CW being communicated using a first DMRS
3 port group and a second DMRS port group, wherein a first version of the CW is
4 communicated from the first DMRS port group and a second version of the CW is
5 communicated from the second DMRS port group.

1 106. The apparatus of claim 105, wherein the first and second versions of
2 the CW comprise a different redundancy version or a different mapping function between the
3 TB and the DMRS port group.

1 107. The apparatus of claim 105, wherein:
2 a first data stream associated with a first version of the TB that is associated
3 with the CW is mapped to the first DMRS port group according to an order comprising a first

4 layer of the first DMRS port group, then a frequency resource allocation of the first DMRS
5 port group, and then a time resource allocation of the first DMRS port group; and
6 a second data stream associated with a second version of the TB that is
7 associated with the CW is mapped to the second DMRS port group according to an order
8 comprising a second layer of the second DMRS port group, then a frequency resource
9 allocation of the second DMRS port group, and then a time resource allocation of the second
10 DMRS port group.

1 108. The apparatus of claim 95, wherein the transmission scheme comprises
2 a transport block (TB) associated with a first CW being communicated using a first DMRS
3 port group and a second DMRS port group, wherein a first portion of the CW is
4 communicated from the first DMRS port group and a second portion of the CW is
5 communicated from the second DMRS port group.

1 109. The apparatus of claim 108, wherein:
2 a first data stream associated with a first portion of the TB that is associated
3 with the CW is mapped to the first DMRS port group according to an order comprising a first
4 layer of the first DMRS port group, then a frequency resource allocation of the first DMRS
5 port group, and then a time resource allocation of the first DMRS port group; and
6 a second data stream associated with a second portion of the TB that is
7 associated with the CW is mapped to the second DMRS port group according to an order
8 comprising a second layer of the second DMRS port group, then a frequency resource
9 allocation of the second DMRS port group, and then a time resource allocation of the second
10 DMRS port group.

1 110. The apparatus of claim 108, wherein the instructions are further
2 executable by the processor to cause the apparatus to:
3 aggregate, based at least in part on an index associated with each DMRS port
4 of the first DMRS port group and the second DMRS port group, the DMRS port of the first
5 DMRS port group and the second DMRS port group to form an aggregated DMRS port;
6 aggregate, based at least in part on an index associated with each resource
7 element associated with a frequency resource allocation and a time resource allocation, the
8 frequency resource allocation and the time resource allocation to form an aggregated
9 frequency resource allocation and an aggregated time resource allocation; and

10 map a data stream of the TB associated with the CW according to the order
11 comprising one or more layers associated with the aggregated DMRS port, then the
12 aggregated frequency resource allocation, and then the aggregated time resource allocation.

1 111. The apparatus of claim 95, wherein the instructions are further
2 executable by the processor to cause the apparatus to:
3 configure a first DMRS port group and a second DMRS port group with a
4 different frequency resource allocation and time resource allocation; and
5 configure the first DMRS port group and the second DMRS port group with
6 different DMRS ports.

1 112. The apparatus of claim 95, wherein the instructions are further
2 executable by the processor to cause the apparatus to:
3 configure a first DMRS port group and a second DMRS port group with a
4 different frequency resource allocation and time resource allocation, wherein the first DMRS
5 port group is active in the frequency resource allocation and time resource allocation
6 associated with the first DMRS port group and the second DMRS port group is active in the
7 frequency resource allocation and time resource allocation associated with the second DMRS
8 port group.

1 113. The apparatus of claim 95, wherein the instructions are further
2 executable by the processor to cause the apparatus to:
3 configure a first DMRS port group and a second DMRS port group to share
4 one or more DMRS ports, but with a different frequency resource allocation and time
5 resource allocation;
6 wherein at least one of a first QCL information, a first rate matching
7 configuration, or a combination thereof, is applied to the shared one or more DMRS ports
8 using a frequency resource allocation and time resource allocation associated with the first
9 DMRS port group; and
10 wherein at least one of a second QCL information, a second rate matching
11 configuration, or a combination thereof, is applied to the shared one or more DMRS ports
12 using a frequency resource allocation and time resource allocation associated with the second
13 DMRS port group.

1 114. The apparatus of claim 95, wherein the DCI message comprises the
2 common parameter set for the one or more DMRS port groups, and the instructions are
3 further executable by the processor to cause the apparatus to:

4 transmit the second DCI message that comprises an indication of a second
5 DMRS port group-specific parameter set.

1 115. The apparatus of claim 114, wherein the indication of the resource
2 comprises an indication of a starting resource block for receiving the second DCI message.

1 116. The apparatus of claim 114, wherein the indication of the resource
2 comprises an indication of a component carrier identifier or a cell identifier, wherein the
3 component carrier identifier or the cell identifier conveys an indication of a starting resource
4 block for receiving the second DCI message.

1 117. The apparatus of claim 114, wherein the indication of the resource
2 comprises an indicator indicating whether a resource allocation for the second DMRS port
3 group is the same as the resource allocation for the first DMRS port group.

1 118. The apparatus of claim 114, wherein the mode indicator indicated in
2 the DCI message conveys an indication of whether a resource allocation for the second
3 DMRS port group is the same as a resource allocation for the first DMRS port group.

1 119. The apparatus of claim 114, wherein the instructions are further
2 executable by the processor to cause the apparatus to:

3 configure, based at least in part on one or more bits or fields in the DCI
4 message that explicitly indicate the resource for the second DCI message, a resource
5 occupancy for the second DCI message.

1 120. The apparatus of claim 114, wherein the instructions are further
2 executable by the processor to cause the apparatus to:

3 receive a signal indicating that at least the second DCI message or at least one
4 DMRS port of the second DMRS port group associated with different portions of a transport
5 block (TB) of a CW could not be decoded; and

6 perform, based at least in part on the signal and the transmission scheme, a
7 retransmission of the second DCI message or the different portion of the TB.

1 121. The apparatus of claim 114, wherein, based at least in part on the
2 transmission scheme, that the first DMRS port group and at least one DMRS port of the
3 second DMRS port group are associated with different transport blocks (TBs), further
4 comprising receiving a first signal indicating a decoding result of a TB associated with the
5 first DMRS port group.

1 122. The apparatus of claim 121, wherein the instructions are further
2 executable by the processor to cause the apparatus to:
3 receive a second signal indicating that at least the second DCI message or a
4 TB associated with the second DMRS port group could not be decoded; and
5 perform, based at least in part on the second signal and the transmission
6 scheme, a retransmission of the second DCI message or the TB associated with the second
7 DMRS port group.

1 123. The apparatus of claim 114, wherein the first DMRS port group and at
2 least one DMRS port of the second DMRS port group are associated with different versions
3 of a transport block (TB), further comprising receiving a first signal indicating a decoding
4 result of the TB.

1 124. The apparatus of claim 123, wherein the instructions are further
2 executable by the processor to cause the apparatus to:
3 receive a second signal indicating that the second DCI message could not be
4 decoded; and
5 perform a retransmission of the second DCI message.

1 125. An apparatus for wireless communication at a user equipment (UE),
2 comprising:
3 means for receiving a downlink control information (DCI) message
4 configuring a downlink transmission of one or more codewords (CWs) associated with one or
5 more demodulation reference signal (DMRS) port groups, wherein the DCI message
6 comprises a mode indicator, a common parameter set for the one or more DMRS port groups,
7 and one or more DMRS port group-specific parameter set;
8 means for determining, based at least in part on the mode indicator, a
9 transmission scheme for the downlink transmission, wherein the transmission scheme

10 comprises an association between the one or more DMRS port groups and the one or more
11 CWs; and

12 means for determining, based at least in part on at least one of the common
13 parameter set for the one or more DMRS port groups, the one or more DMRS port group-
14 specific parameter set, or a combination thereof, at least one of a quasi-co-located (QCL)
15 information, a rate matching configuration, a resource allocation, or a combination thereof,
16 for at least one DMRS port group.

1 126. An apparatus for wireless communication at a base station, comprising:
2 means for determining that a downlink transmission to a user equipment (UE)
3 is to occur, the downlink transmission comprising one or more codewords (CWs) associated
4 with one or more demodulation reference signal (DMRS) port groups;

5 means for configuring a downlink control information (DCI) message to
6 indicate a mode indicator, a common parameter set for the one or more DMRS port groups,
7 and one or more DMRS port group-specific parameter set, wherein the mode indicator
8 provides an indication of the association between the one or more DMRS port groups and the
9 one or more CWs being communicated during the downlink transmission; and

10 means for transmitting the DCI message to configure the downlink
11 transmission.

1 127. A non-transitory computer-readable medium storing code for wireless
2 communication at a user equipment (UE), the code comprising instructions executable by a
3 processor to:

4 receive a downlink control information (DCI) message configuring a downlink
5 transmission of one or more codewords (CWs) associated with one or more demodulation
6 reference signal (DMRS) port groups, wherein the DCI message comprises a mode indicator,
7 a common parameter set for the one or more DMRS port groups, and one or more DMRS
8 port group-specific parameter set;

9 determine, based at least in part on the mode indicator, a transmission scheme
10 for the downlink transmission, wherein the transmission scheme comprises an association
11 between the one or more DMRS port groups and the one or more CWs; and

12 determine, based at least in part on at least one of the common parameter set
13 for the one or more DMRS port groups, the one or more DMRS port group-specific

14 parameter set, or a combination thereof, at least one of a quasi-co-located (QCL) information,
15 a rate matching configuration, a resource allocation, or a combination thereof, for at least one
16 DMRS port group.

1 128. A non-transitory computer-readable medium storing code for wireless
2 communication at a base station, the code comprising instructions executable by a processor
3 to:

4 determine that a downlink transmission to a user equipment (UE) is to occur,
5 the downlink transmission comprising one or more codewords (CWs) associated with one or
6 more demodulation reference signal (DMRS) port groups;

7 configure a downlink control information (DCI) message to indicate a mode
8 indicator, a common parameter set for the one or more DMRS port groups, and one or more
9 DMRS port group-specific parameter set, wherein the mode indicator provides an indication
10 of the association between the one or more DMRS port groups and the one or more CWs
11 being communicated during the downlink transmission; and

12 transmit the DCI message to configure the downlink transmission.

1

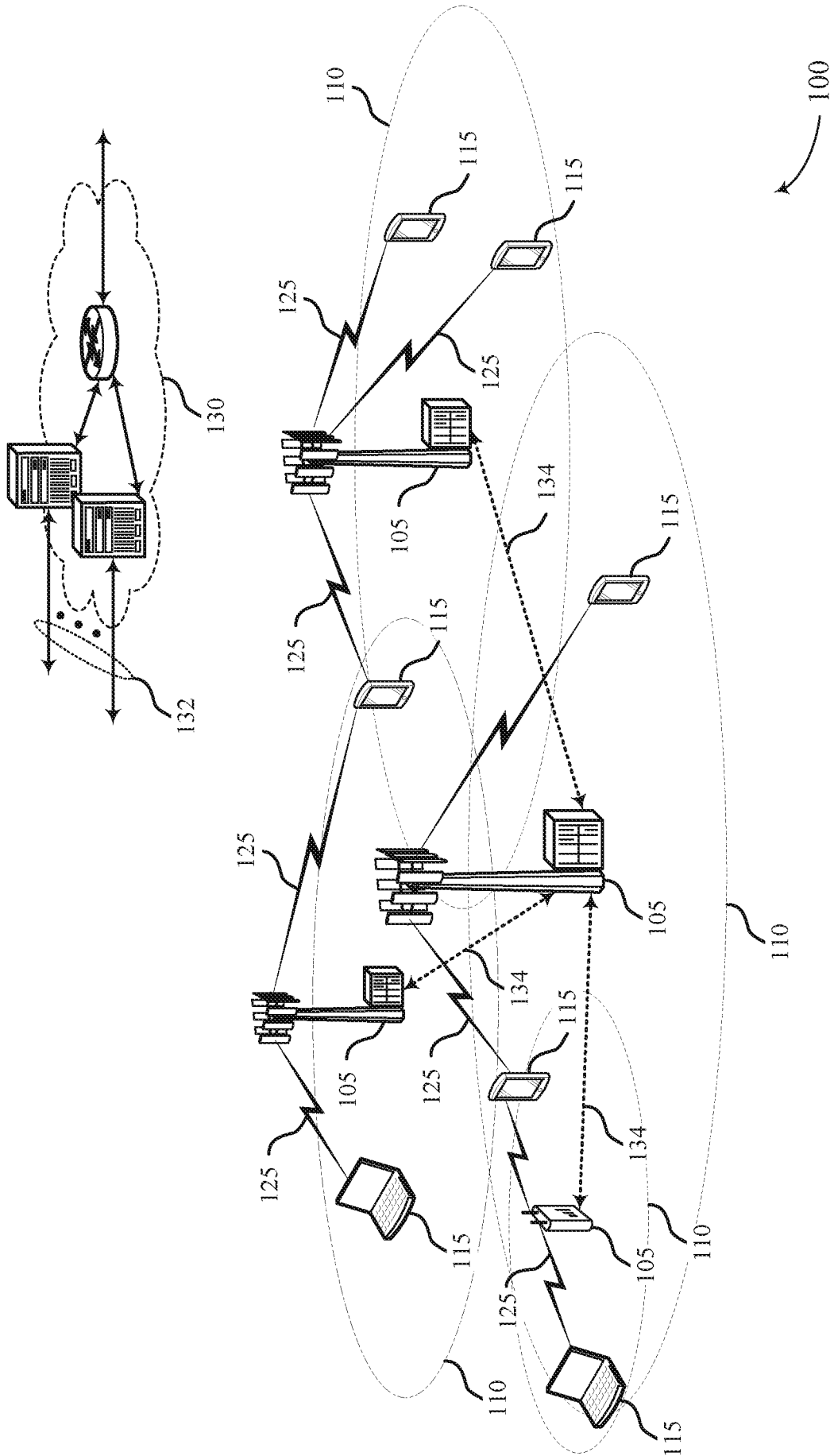

FIG. 1

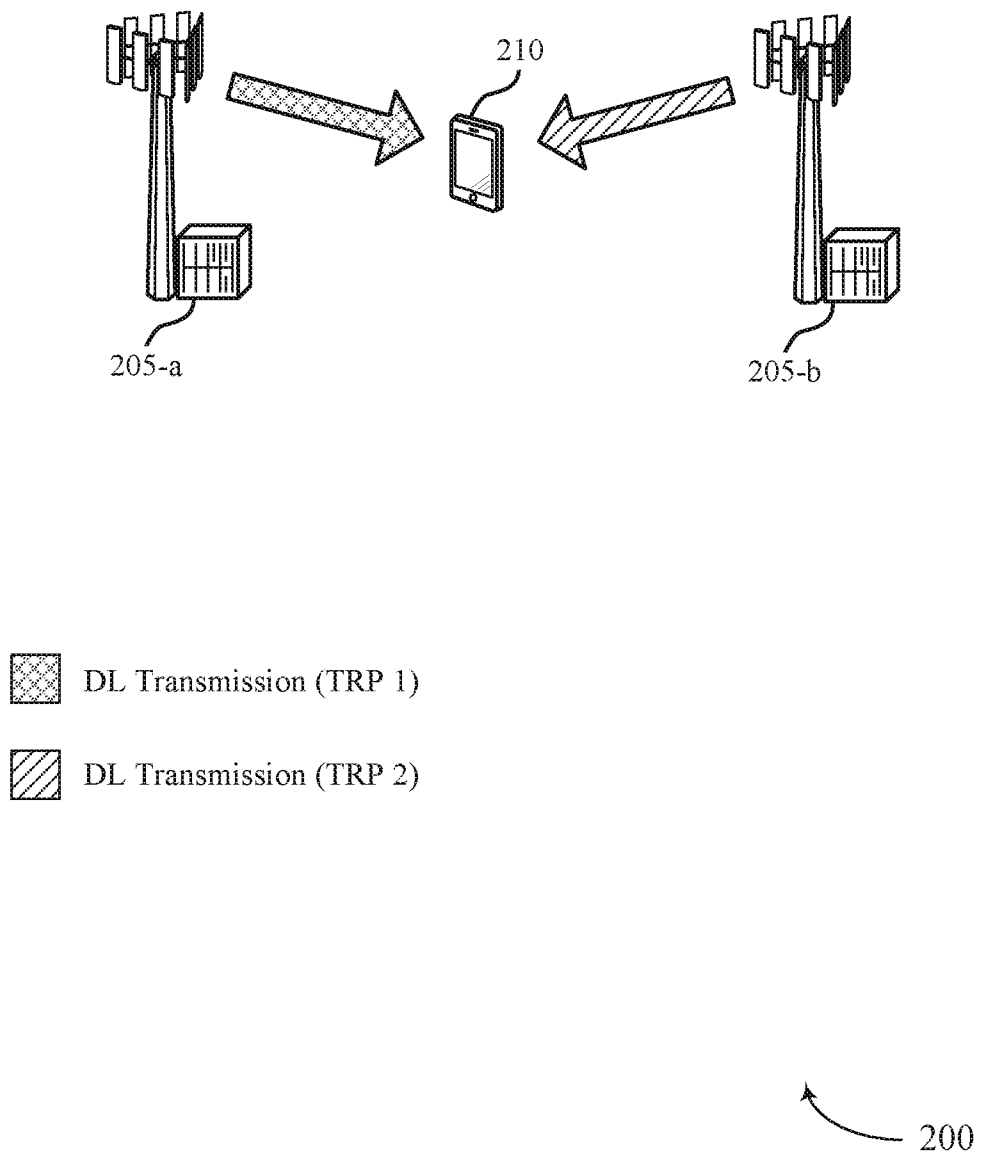

FIG. 2

<u>DCI Bit(s)/Field</u>	<u>Contents</u>
Mode Indicator <u>305</u>	Indicates Transmission Scheme (e.g., Association between CW and DMRS Configurations for TRP1 and TRP 2)
CW Information <u>310</u>	E.g., MCS, NDI, RV for TRP1 and TRP2
HARQ Process Number <u>315</u>	An identifier for each HARQ process
HARQ Timing <u>320</u>	A timing parameter for each HARQ process
DL Assignment Index <u>325</u>	An Index identifying all of the downlink data communicated during the downlink transmission that has been bundled into one HARQ ACK/NACK feedback transmission
Resource Allocation <u>330</u>	Identifies Time and/or Frequency resources allocated to one or more TRPs to use during the downlink transmission
DMRS1 Configuration Information <u>335</u>	<ul style="list-style-type: none"> • DMRS Configuration • QCL (TCI) Information • Rate Matching
DMRS2 Configuration Information <u>340</u>	<ul style="list-style-type: none"> • DMRS Configuration • QCL (TCI) Information • Rate Matching

300



FIG. 3

<u>DCI Bit(s)/Field</u>	<u>Contents</u>
Mode Indicator <u>405</u>	Indicates Transmission Scheme (e.g., Association between CW and DMRS Configurations for TRP1 and TRP 2)
CW Information <u>410</u>	E.g., MCS, NDI, RV for TB1 and TB2
HARQ Process Number <u>415</u>	An identifier for each HARQ process
HARQ Timing <u>420</u>	A timing parameter for each HARQ process
DL Assignment Index <u>425</u>	An Index identifying all of the downlink data communicated during the downlink transmission that has been bundled into one HARQ ACK/NACK feedback transmission
DMRS1 Configuration Information <u>430</u>	<ul style="list-style-type: none"> • Time/Frequency Resource Allocation • DMRS Configuration • QCL (TCI) Information • Rate Matching
DMRS2 Configuration Information <u>435</u>	<ul style="list-style-type: none"> • Time/Frequency Resource Allocation • DMRS Configuration • QCL (TCI) Information • Rate Matching

400

FIG. 4

<u>DCI Bit(s)/Field</u>	<u>Contents</u>
Mode Indicator <u>505</u>	Indicates Transmission Scheme (e.g., Association between CW and DMRS Configurations for TRP1 and TRP 2)
CW Information <u>510</u>	E.g., MCS, NDI, RV for TB1 and TB2
HARQ Process Number <u>515</u>	An identifier for each HARQ process
HARQ Timing <u>520</u>	A timing parameter for each HARQ process
DL Assignment Index <u>525</u>	An Index identifying all of the downlink data communicated during the downlink transmission that has been bundled into one HARQ ACK/NACK feedback transmission
DMRS Port Configuration <u>530</u>	DMRS port group/port configuration information
DMRS1 Configuration Information <u>535</u>	<ul style="list-style-type: none"> • Time/Frequency Resource Allocation • QCL (TCI) Information (Resource-Specific QCL, only applied to RA1) • Rate Matching
DMRS2 Configuration Information <u>540</u>	<ul style="list-style-type: none"> • Time/Frequency Resource Allocation • QCL (TCI) Information (Resource-Specific QCL, only applied to RA2) • Rate Matching

500

FIG. 5

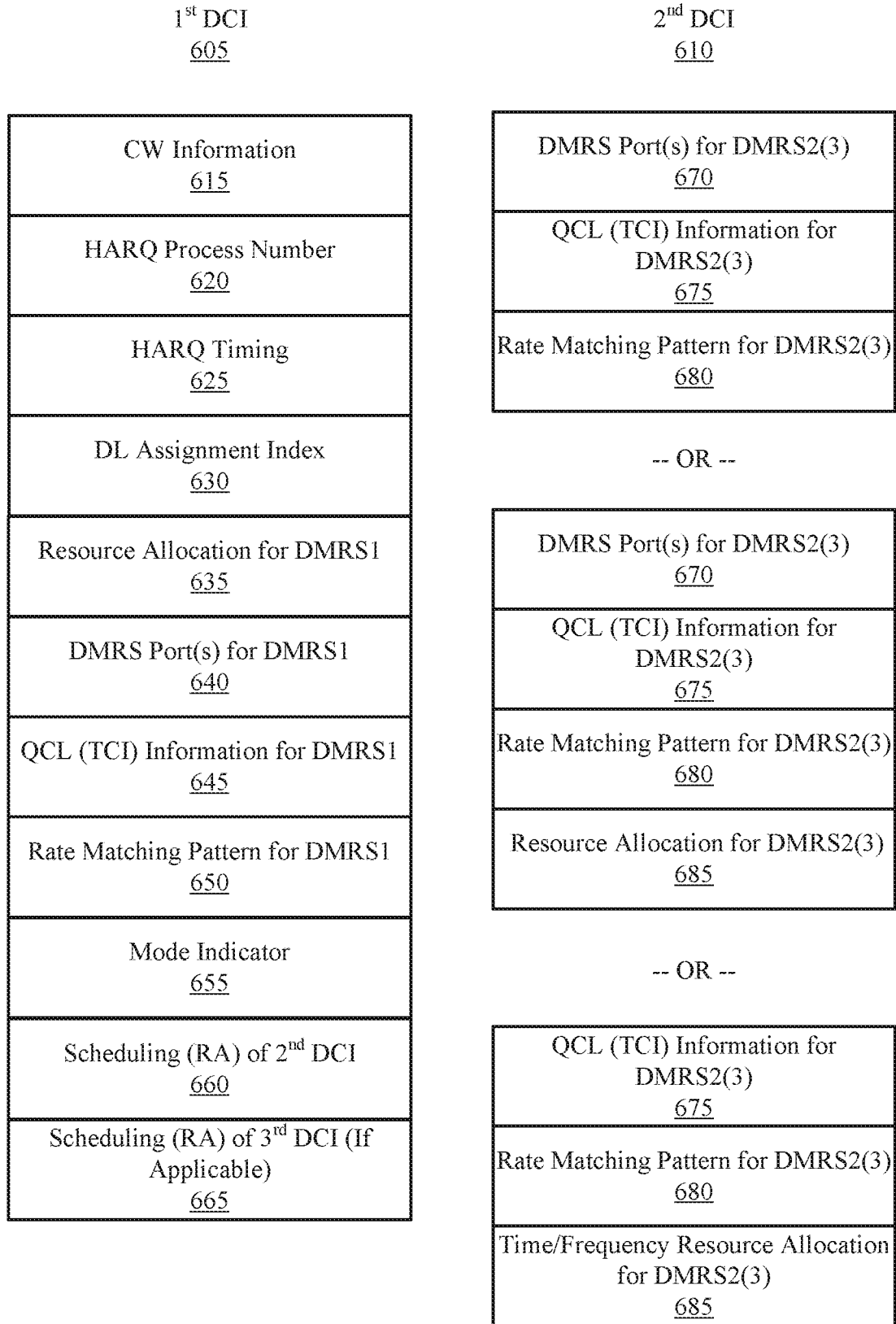

↖ 600

FIG. 6

7/18

1st DCI
705

2nd DCI
710

CW Information <u>715</u>
HARQ Process Number <u>720</u>
HARQ Timing <u>725</u>
DL Assignment Index <u>730</u>
Resource Allocation for DMRS1 <u>735</u>
DMRS Port(s) for DMRS1/2(/3) <u>740</u>
QCL (TCI) Information for DMRS1 <u>745</u>
Rate Matching Pattern for DMRS1 <u>750</u>
Mode Indicator <u>755</u>
Scheduling (RA) of 2 nd DCI <u>760</u>
Scheduling (RA) of 3 rd DCI (If Applicable) <u>765</u>

QCL (TCI) Information for DMRS2(3) <u>775</u>
Rate Matching Pattern for DMRS2(3) <u>780</u>

-- OR --

QCL (TCI) Information for DMRS2(3) <u>775</u>
Rate Matching Pattern for DMRS2(3) <u>780</u>
Resource Allocation for DMRS2(3) <u>785</u>

700

FIG. 7

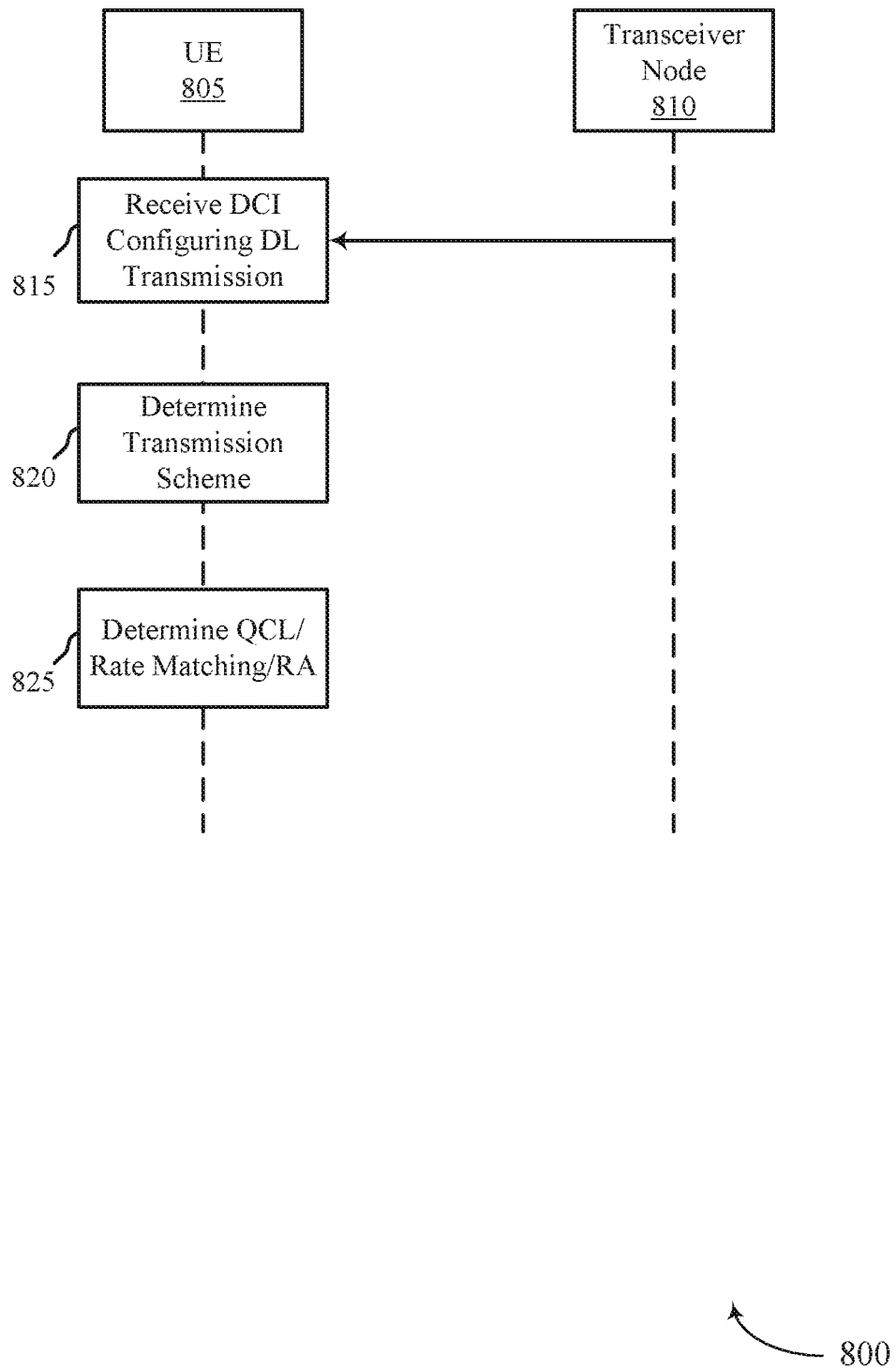
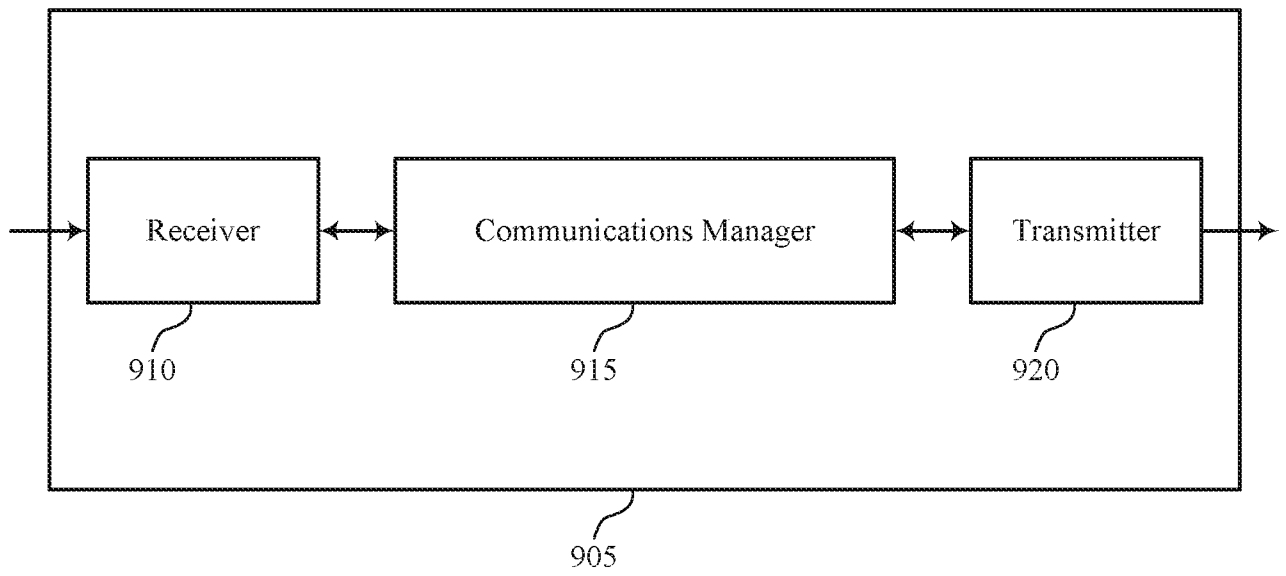

FIG. 8



900

FIG. 9

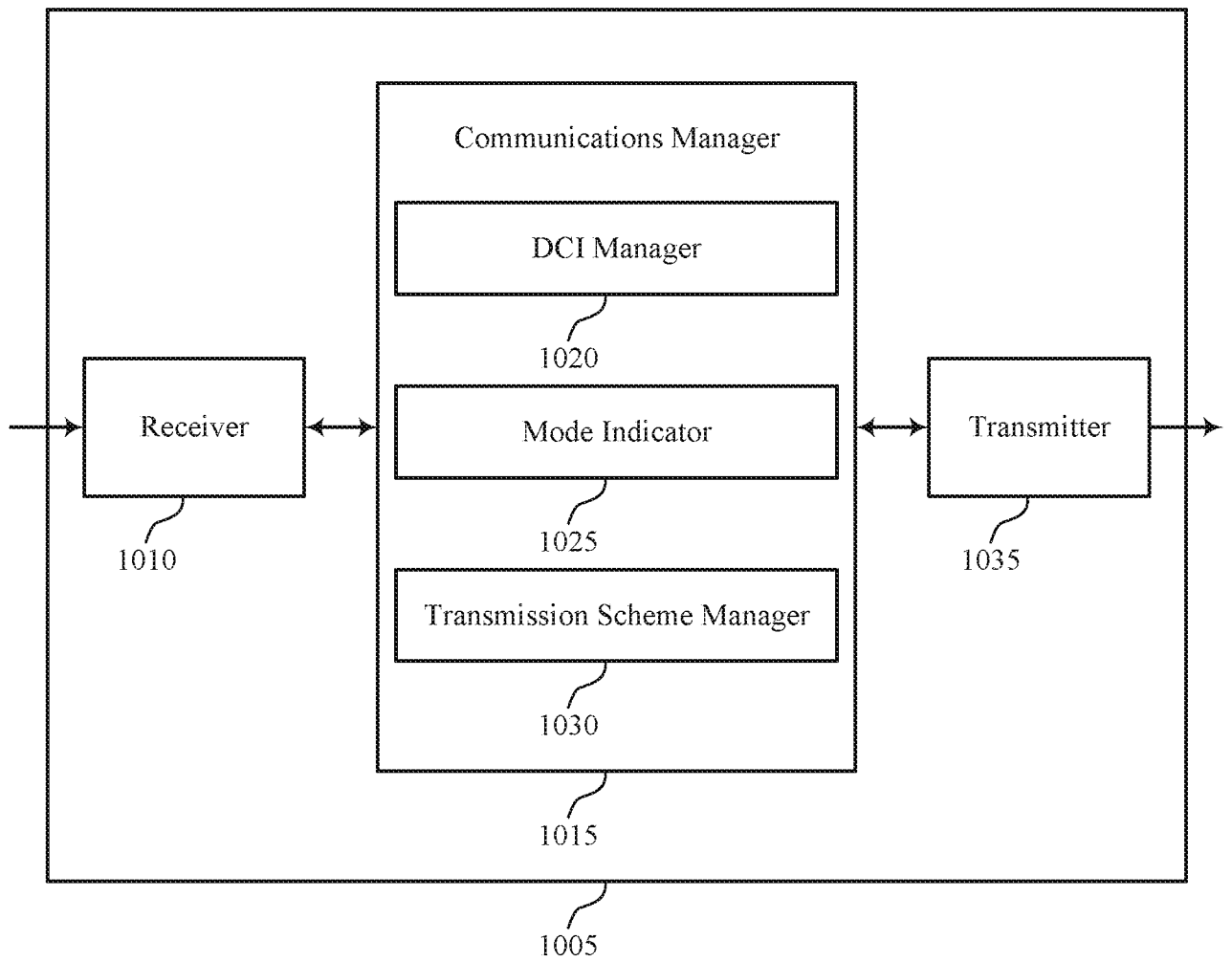
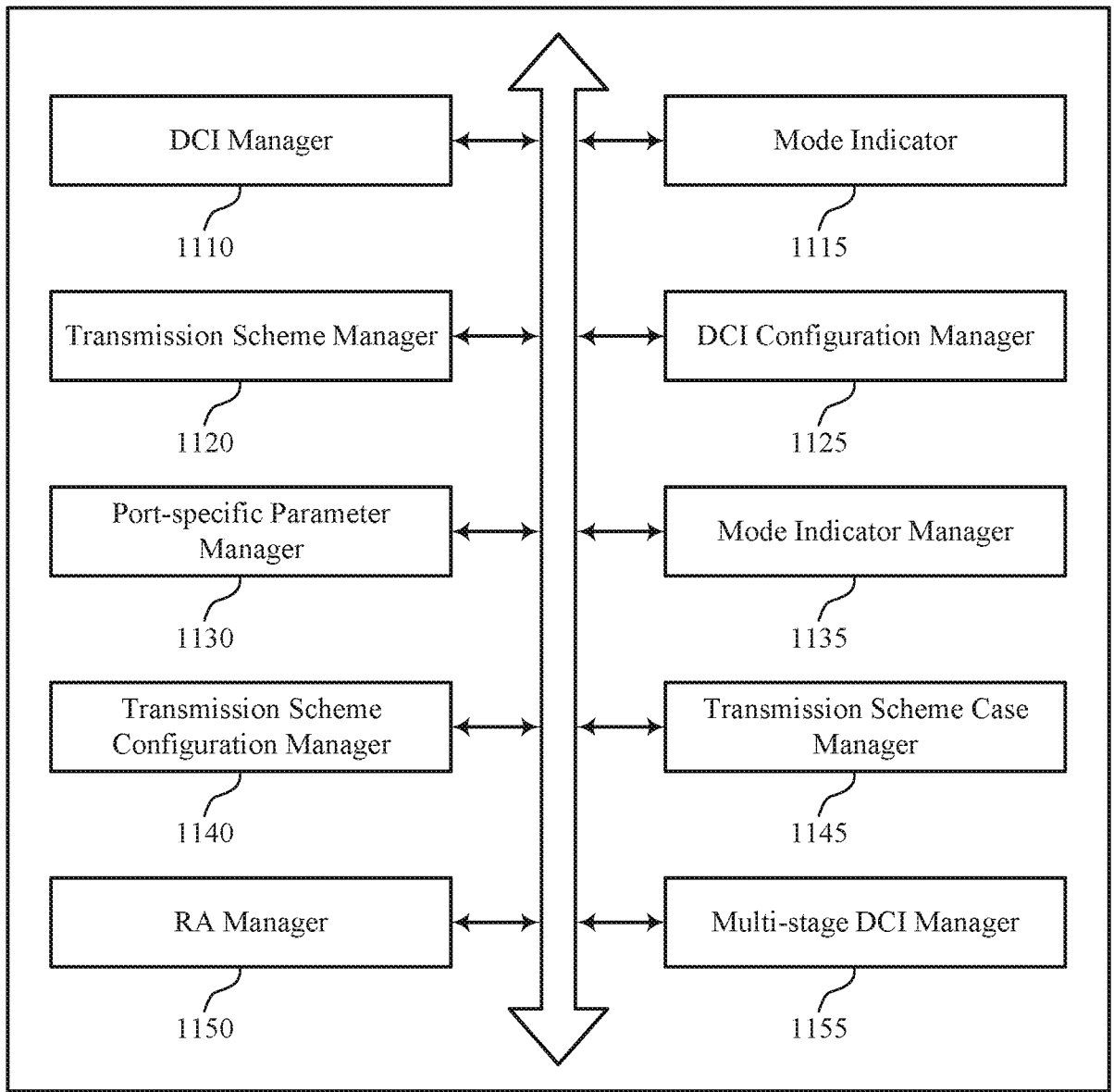

FIG. 10



1105

1100

FIG. 11

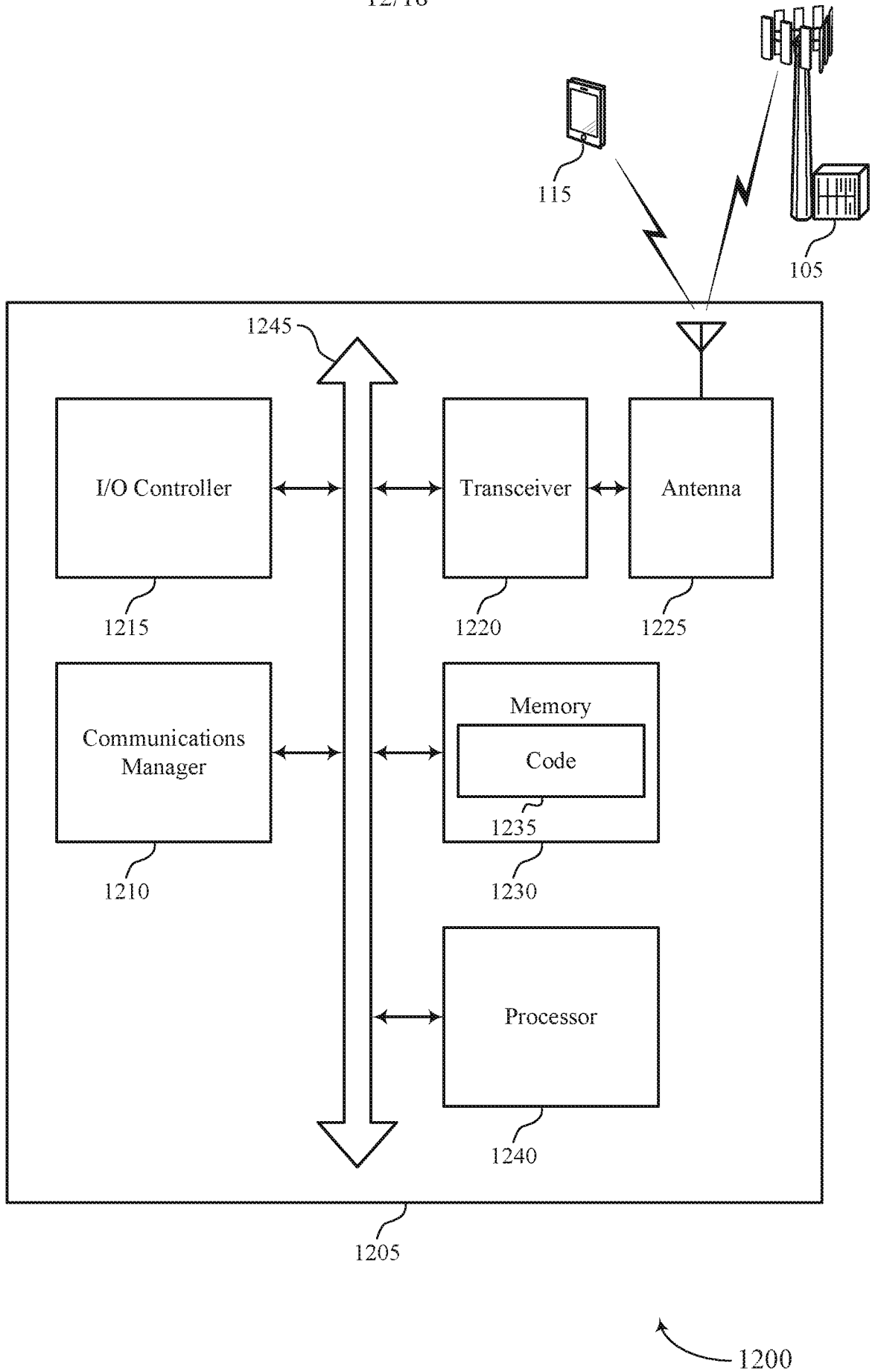

FIG. 12

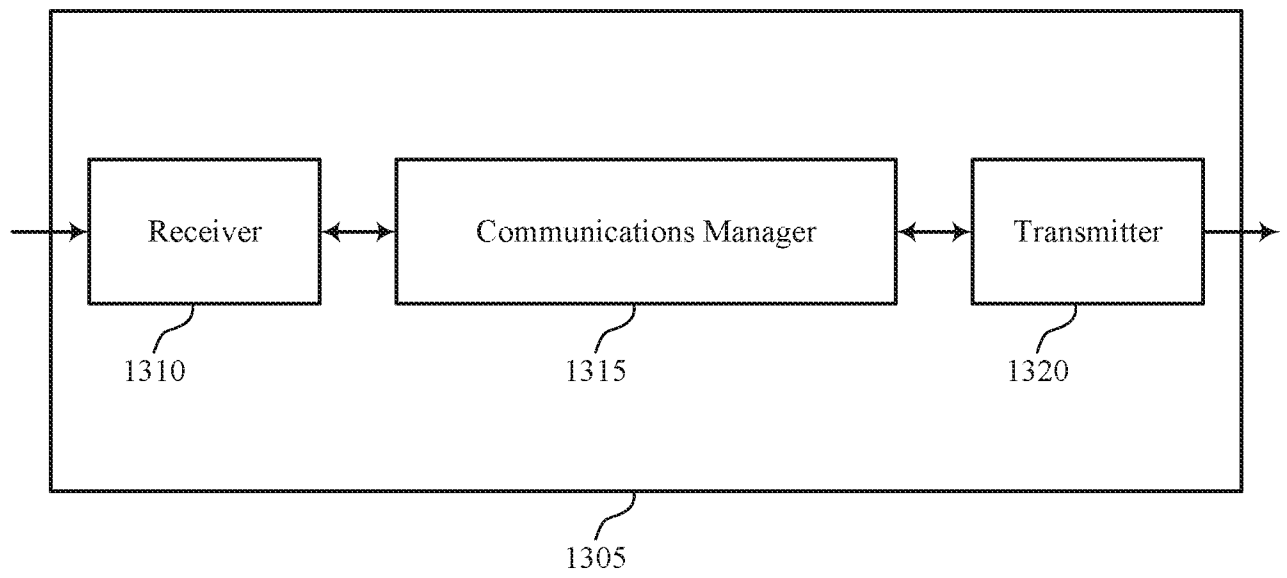
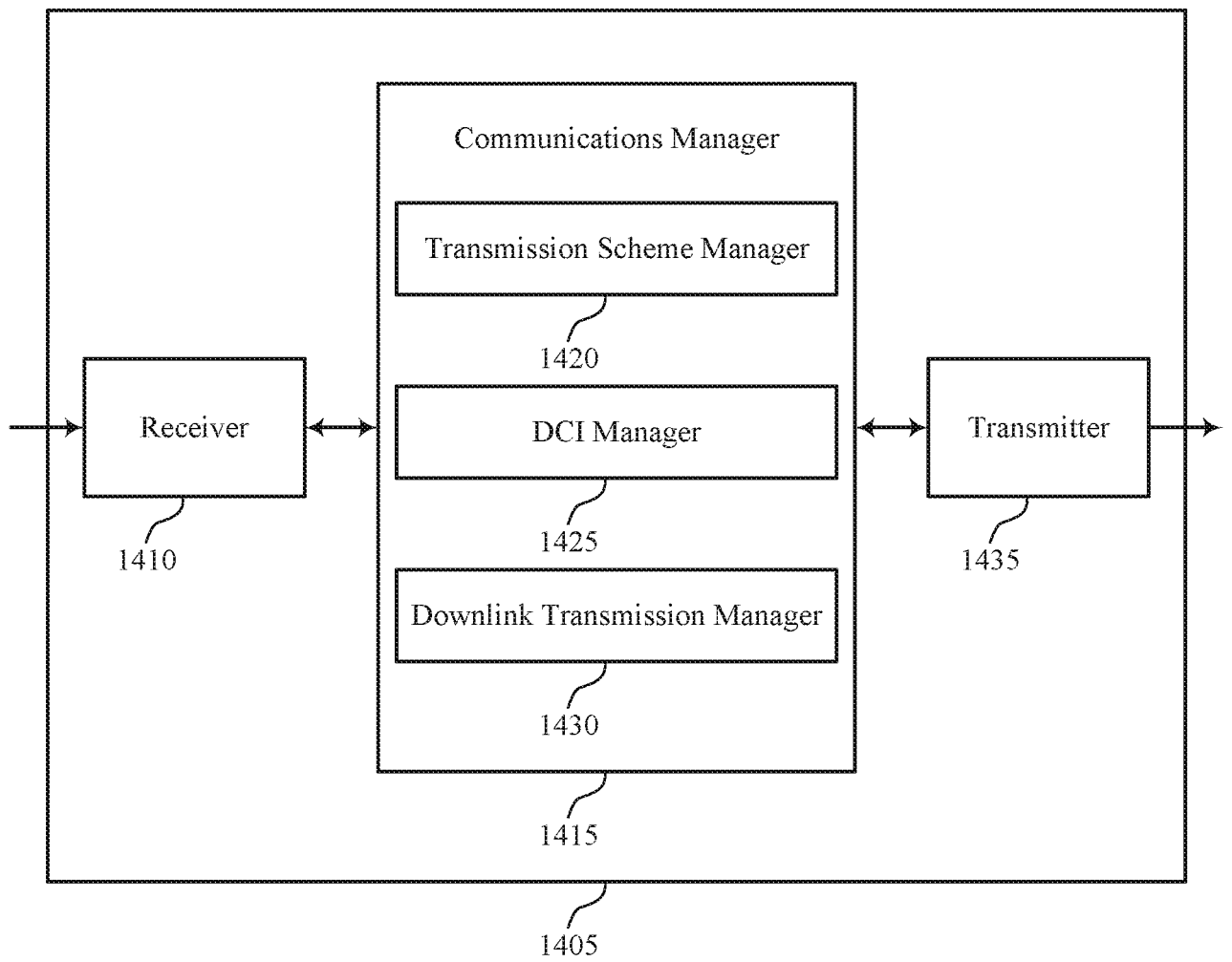

FIG. 13



1400

FIG. 14

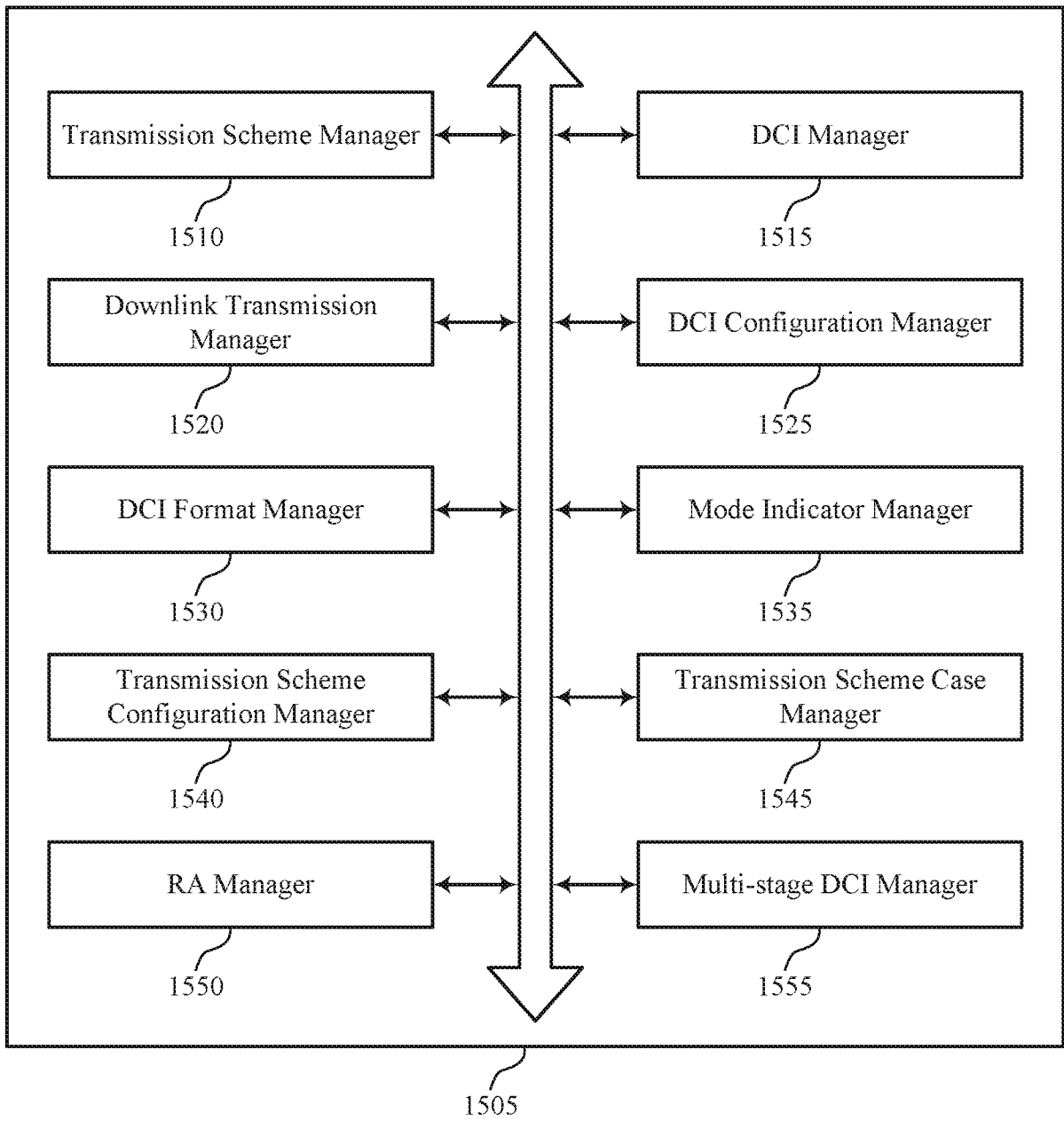

FIG. 15

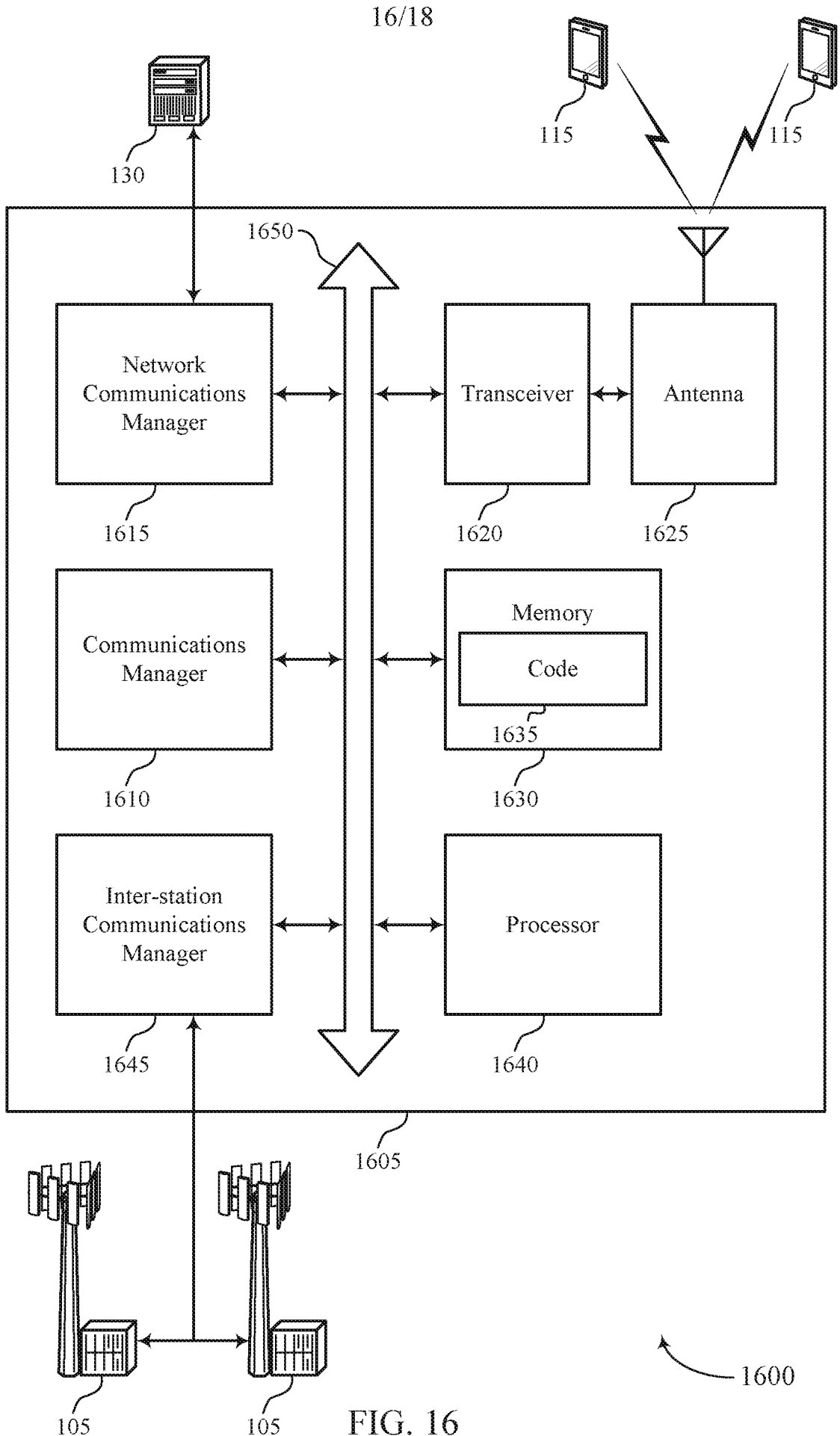

FIG. 16

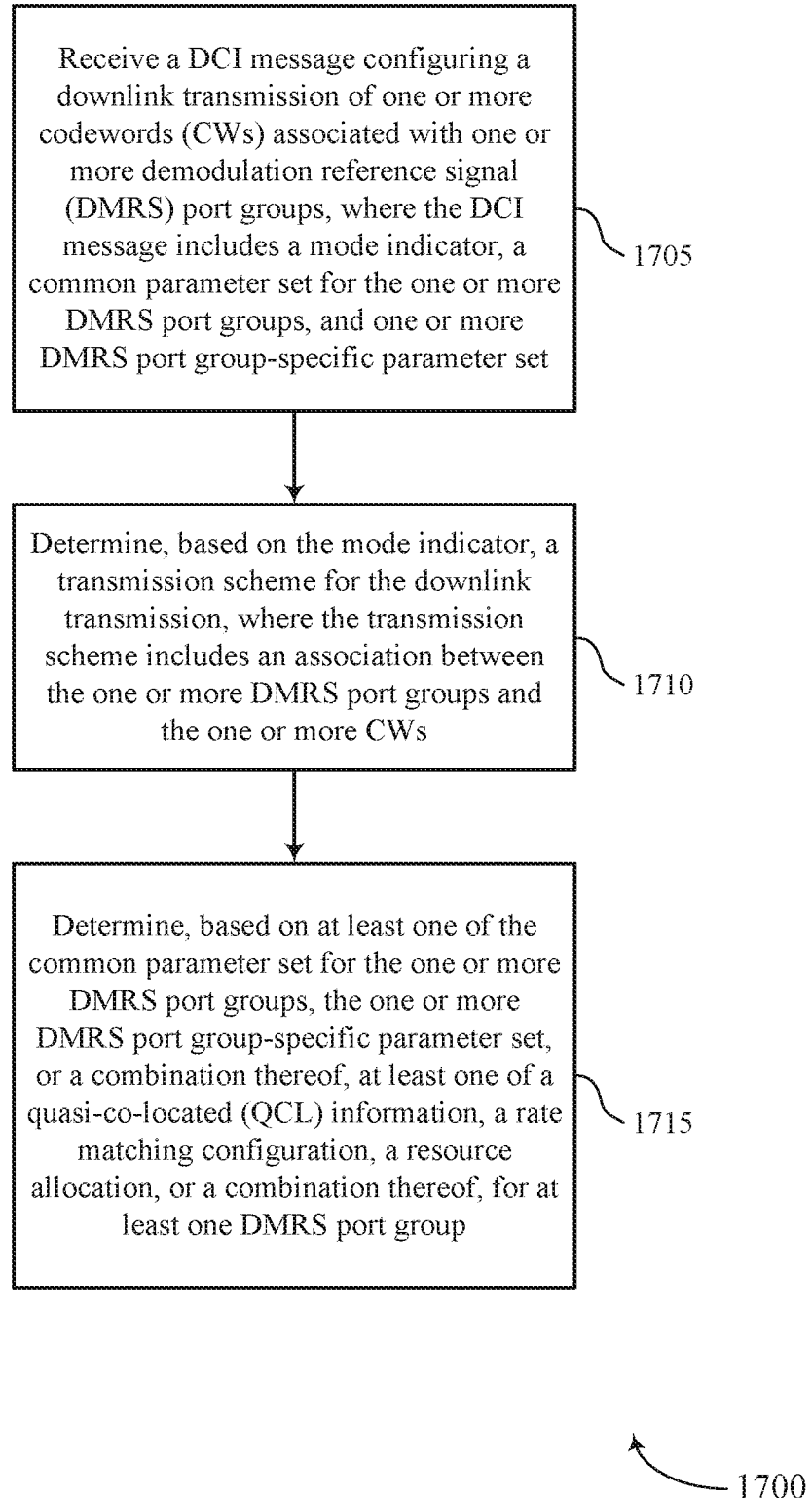
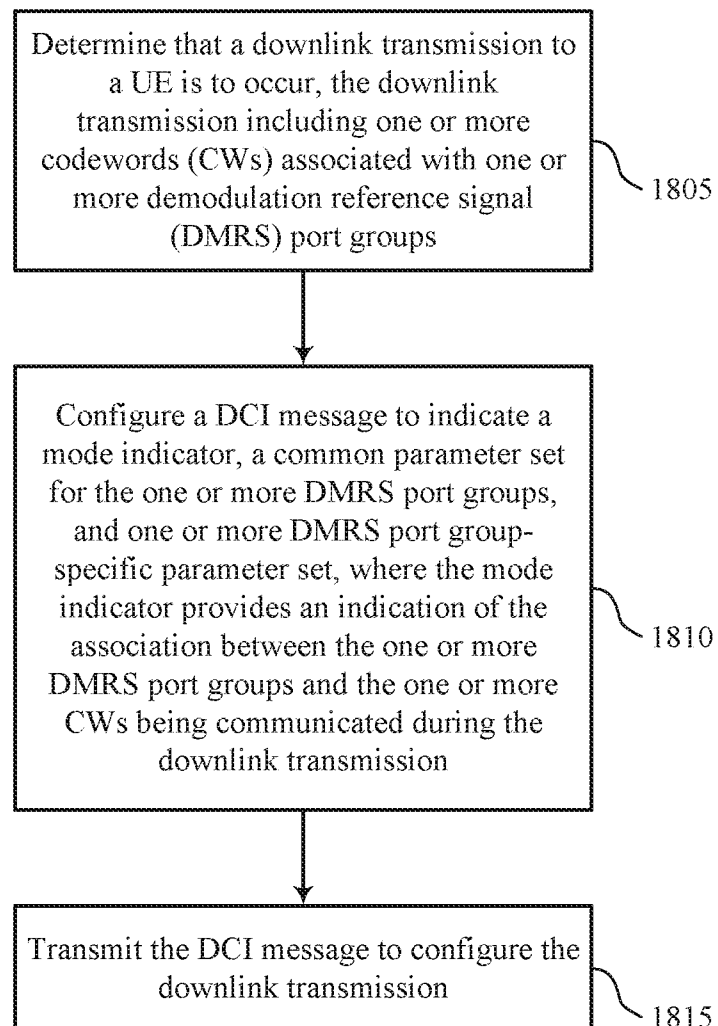

FIG. 17

18/18



1800

FIG. 18

INTERNATIONAL SEARCH REPORT

International application No.

PCT/CN2018/102996

A. CLASSIFICATION OF SUBJECT MATTER

H04B 7/024(2017.01)i

According to International Patent Classification (IPC) or to both national classification and IPC

B. FIELDS SEARCHED

Minimum documentation searched (classification system followed by classification symbols)

H04B; H04W; H04Q

Documentation searched other than minimum documentation to the extent that such documents are included in the fields searched

Electronic data base consulted during the international search (name of data base and, where practicable, search terms used)

EPODOC, WPI, CNPAT, CNKI: QCL, rate w matching, DMRS, port?, group, DCI, codeword, CW, resource w allocat+, indicat+, UE, TRP?.

C. DOCUMENTS CONSIDERED TO BE RELEVANT

Category*	Citation of document, with indication, where appropriate, of the relevant passages	Relevant to claim No.
X	WO 2018026241 A1 (SAMSUNG ELECTRONICS CO., LTD.) 08 February 2018 (2018-02-08) paragraphs [102], [118] - [136], [240]	1-128
A	CN 102158302 A (CHINA ACADEMY OF TELECOMMUNICATIONS TECHNOLOGY) 17 August 2011 (2011-08-17) the whole document	1-128
A	EP 3171558 A1 (LG ELECTRONICS INC.) 24 May 2017 (2017-05-24) the whole document	1-128
A	WO 2017028750 A1 (CHINA MOBILE COMMUNICATIONS CORPORATION) 23 February 2017 (2017-02-23) the whole document	1-128

 Further documents are listed in the continuation of Box C. See patent family annex.

* Special categories of cited documents:

"A" document defining the general state of the art which is not considered to be of particular relevance

"E" earlier application or patent but published on or after the international filing date

"L" document which may throw doubts on priority claim(s) or which is cited to establish the publication date of another citation or other special reason (as specified)

"O" document referring to an oral disclosure, use, exhibition or other means

"P" document published prior to the international filing date but later than the priority date claimed

"T" later document published after the international filing date or priority date and not in conflict with the application but cited to understand the principle or theory underlying the invention

"X" document of particular relevance; the claimed invention cannot be considered novel or cannot be considered to involve an inventive step when the document is taken alone

"Y" document of particular relevance; the claimed invention cannot be considered to involve an inventive step when the document is combined with one or more other such documents, such combination being obvious to a person skilled in the art

"&" document member of the same patent family

Date of the actual completion of the international search

13 May 2019

Date of mailing of the international search report

03 June 2019

Name and mailing address of the ISA/CN

National Intellectual Property Administration, PRC
6, Xitucheng Rd., Jimen Bridge, Haidian District, Beijing
100088
China

Authorized officer

WANG, Mengsi

Facsimile No. (86-10)62019451

Telephone No. 86-(10)-53961642

INTERNATIONAL SEARCH REPORT
Information on patent family members

International application No.

PCT/CN2018/102996

Patent document cited in search report			Publication date (day/month/year)	Patent family member(s)			Publication date (day/month/year)
WO	2018026241	A1	08 February 2018	KR	20190026964	A	13 March 2019
				US	2018042028	A1	08 February 2018
CN	102158302	A	17 August 2011	None			
EP	3171558	A1	24 May 2017	KR	20170031647	A	21 March 2017
				CA	2943831	A1	21 January 2016
				CN	106256107	A	21 December 2016
				JP	2017516426	A	15 June 2017
				WO	2016010379	A1	21 January 2016
				US	2017207932	A1	20 July 2017
WO	2017028750	A1	23 February 2017	US	2019013916	A1	10 January 2019
				CN	106470087	A	01 March 2017
				EP	3340515	A1	27 June 2018