

Oct. 30, 1928.

1,689,322

H. E. BROOKBY ET AL

APPARATUS FOR MAKING PLASTER WALLBOARD

Filed March 1, 1926

2 Sheets-Sheet 1

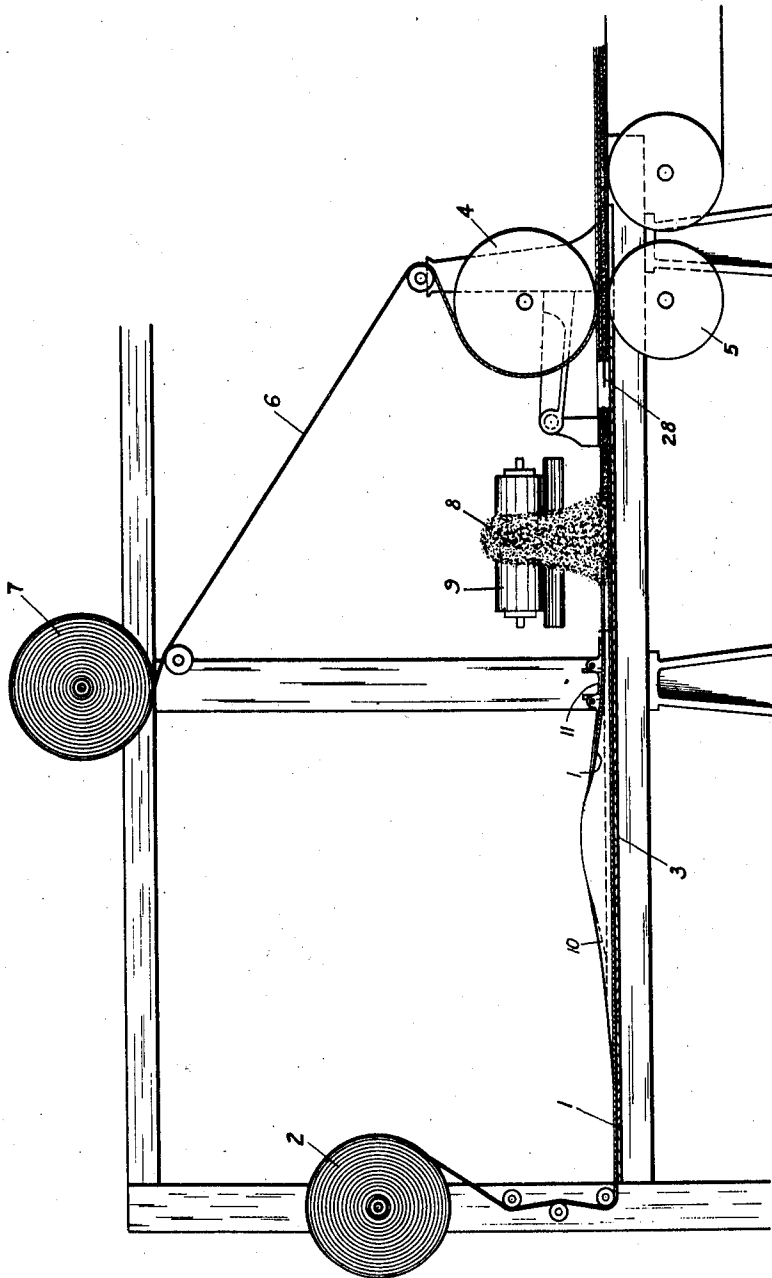

Fig. 1

INVENTORS
HARRY E. BROOKBY
CARL ABSMEIER

BY

Keith W. Konnell
ATTORNEY

Oct. 30, 1928.

1,689,322

H. E. BROOKBY ET AL
APPARATUS FOR MAKING PLASTER WALLBOARD

Filed March 1, 1926

2 Sheets-Sheet 2

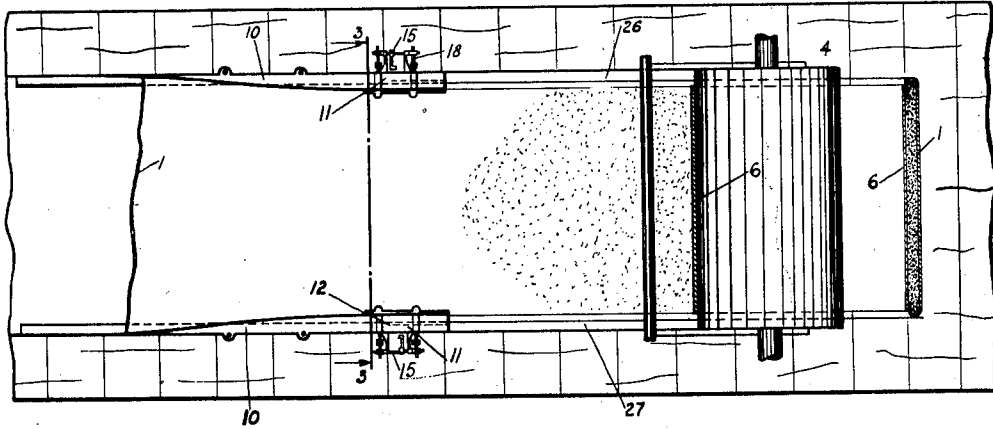

Fig. 2

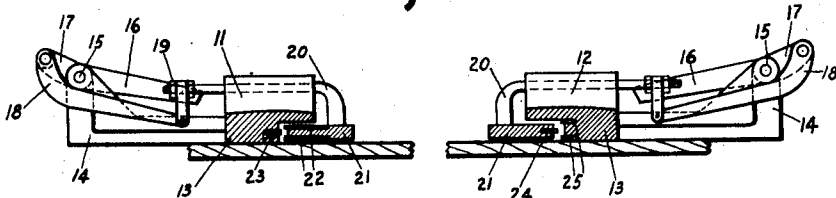

Fig. 3

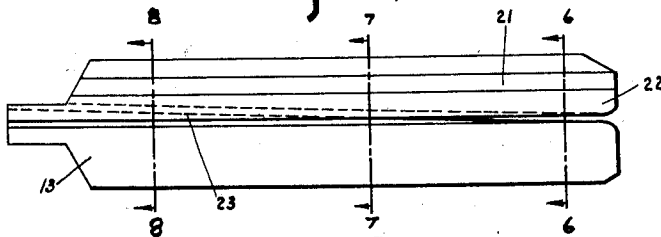

Fig. 4

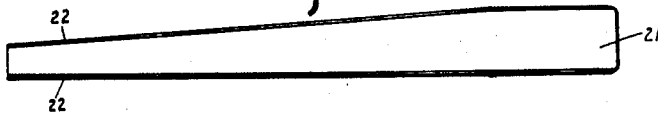

Fig. 5

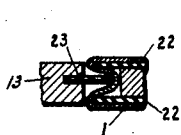

Fig. 6

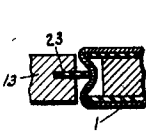

Fig. 7

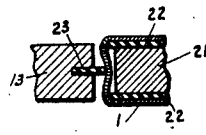

Fig. 8

INVENTORS
HARRY E. BROOKBY
CARL ABSMEIER

BY

Kent H. Russell
ATTORNEY

UNITED STATES PATENT OFFICE.

HARRY E. BROOKBY, OF EVANSTON, ILLINOIS, AND CARL ABSMEIER, OF GRAND RAPIDS, MICHIGAN, ASSIGNORS TO UNITED STATES GYPSUM COMPANY, OF CHICAGO, ILLINOIS, A CORPORATION OF ILLINOIS.

APPARATUS FOR MAKING PLASTER WALL BOARD.

Application filed March 1, 1926. Serial No. 91,297.

This invention relates more particularly to the making of a plaster board or a plaster wall-board which has a co-operating tongue and groove at its opposite edges, and the principal object of the invention is, therefore, to provide a suitable mechanism for forming the tongue and groove in the opposite edges of a fibrous cover sheet; to provide means for maintaining the formed cover sheet in shape when the plastic mass is applied thereto; to suitably reinforce the formed tongue and groove under the board forming means or pressure rolls; to make the tongue and groove edge forming means readily adjustable and easily manipulated for the insertion and removal of the paper; and in general to provide suitable apparatus for carrying out the method herein shown and described.

In the plaster board and plaster wallboard now on the market the edges are square, or substantially so, in both the raw or open edged board, and in the covered or enclosed type of plaster board. It is an object of the present invention to provide a covered plaster board with formed edges which co-operate, the tongue of one edge engaging in and being centered by the groove of an adjacent similarly formed plaster or wallboard. The result of this construction is that not only is a more perfect joint formed between adjacent wallboards, but also the engaging edges mutually support and strengthen each other so that a more rigid covering and structure is made. This is particularly shown in wall-board of this type used as sheathing.

In the accompanying drawings, Fig. 1 is an elevation with parts shown in section illustrating the apparatus for carrying out this invention; Fig. 2 is a plan view of a portion of the apparatus shown in Fig. 1; Fig. 3 is a detail section taken on the line 3—3 of Fig. 2; Fig. 4 is a plan of two edge forming plates; Fig. 5 is an elevation of one of the edge forming plates; and Figs. 6, 7, and 8 are detail sectional views illustrating the formation of one edge of the fibrous cover sheet as if taken on the line 6—6, 7—7, and 8—8 respectively of Fig. 4.

Referring more particularly to the drawing, the making of a composition board is illustrated which comprises the continuous supplying of a bottom fibrous cover sheet 1

from a roll 2 and the drawing of this cover sheet over a base or bed plate 3 through a board forming means comprising an upper pressure roller 4 and a bottom roller 5. An upper fibrous cover sheet 6 is continuously supplied from a roll 7 and passes about the pressure roller 4 in forming the board. In advance of the board forming roller 4 a mass of plastic material 8 is continuously supplied and deposited on top of the bottom sheet 1 by means of a transverse conveyor belt 9 or any other suitable conveying means.

The edges of the bottom cover sheet 1 are first bent up and then are formed into the desired tongue and groove shape before the application of the plastic mass 8, and while the bottom sheet is moving up toward the board forming roller and passing beneath it, it is necessary to support or maintain the formed edges of the bottom cover sheet in order that they are not forced out by the plastic mass when the pressure of the roller 4 is applied thereto. This apparatus and the method employed constitutes the novel subject matter in the present application.

Supported on each side of the bed plate 3 are plates or folders 10 adapted to engage the edges only of the bottom cover sheet 1 which are folded up and turned inwardly and are then passed through the edging devices 11 and 12, one of which forms a groove in the edge of the cover sheet and the other a longitudinal projection or tongue, so that the tongue and groove of adjacent boards will fit more or less closely one within the other, thereby aligning the board and placing their surfaces in the same plane.

Each of the edging devices 11 and 12 has a main block portion 13 from which the arms 14 extend outwardly and provide a mounting for a shaft 15. An operating arm 16 is mounted between the ends of shaft 15 and the short arms 17 are mounted on the shaft at the ends thereof and pivotally engage links 18, each of which is adjustably connected by means of nuts 19 to a rod 20 which extends through the block 13 and supports a movable bar 21 at the inner end thereof. The bars 21 carry edging plates which co-operate with similar plates mounted in the blocks 13 to form the proper edges in the edge of the cover sheet. In the edging device 11 the bar 21

carries two plates 22 which co-operate with the plate 23 fixed in the block 13 to form a groove at this edge of the lower cover sheet 1.

The other edging device 12 carries a plate 24 on the bar 21 which co-operates with two plates 25 carried by the block 13, which together form a longitudinal tongue at this side of the cover sheet 1.

In order to crease or fold the edges of the cover sheet without cracking or breaking the edges, it is necessary that the edges be folded gradually, or at least not too abruptly which is one of the reasons for turning over the edges by means of the plates 10. The edges of the cover sheet are then drawn through the edging devices 11 and 12, each edging device gradually changing the fold of the edge as it passes through as shown more clearly by Figs. 4 to 8 inclusive. When the cover sheet is first started through the edging device, it is given only a slight bend as shown in Fig. 6; as the paper progresses through the edging device the plates 22 and 23 project toward each other to a greater extent forming a deeper crease or groove in the sheet 1, as shown by Fig. 7, and continuing in this same manner until the edge of the sheet is folded to a greater extent than is probably necessary as shown in Fig. 8. The upper plate 22 as shown in Fig. 5 gradually approaches the lower plate 23 so that the same amount of material of the cover sheet which is embraced between the outer plates 22 at the start of the creasing operation is also included in the final crimping operations as shown in Fig. 8. The reason for creasing or crimping the paper to a greater extent than is actually necessary is that the paper naturally retains a certain amount of resiliency and as soon as the cover sheet has passed the edging device the material thereof will tend to straighten out to a certain extent, whether it be the tongue or grooved edge of the cover sheet.

Adjusting nuts 19 at the end of the bar 20 are for varying the tension which the bars 21 and the plates carried thereby apply to the paper passing through the edging device. Hand levers 16 are provided for quickly operating the bar 21 so that the edges of the cover sheet 1 can be quickly inserted through the edging devices in starting up the machine, or removed, or for making any necessary adjustment or repairs. The axis of the shaft 15 is disposed at one side of the line connecting the pivots of the link 18 in the closed position of the bar 21 so that operating member 16 and the bar 21 will stay in place until manually moved by the operation of the member 16 to the opposite side of the link 18 pivot line.

After passing the edge formers the lower cover sheet 1 must have its crimped or folded edges supported in order to retain the plastic material 8 thereon, and also to main-

tain the formed edges in the sheet itself. Side bars 26 and 27 are therefore provided which extend from the edging devices 11 and 12 to and slightly beyond the vertical center of the board forming roller 4. These side bars 26 and 27 are provided a longitudinal groove or a tongue 28 as shown in Fig. 1 which may extend the entire distance from the edging devices to and beyond the board forming roll 4, or may extend only a portion of the distance but must be directly under the roll 4 and for a distance in advance of the roll to maintain the formed edge in the lower cover sheet at the time that pressure is applied by the forming roll so that the plastic material will not be forced by the pressure of the forming roll to straighten out the formed edges in the cover sheet. As soon as the formed board is past the forming roll 4 there is no longer any pressure on the board and the tongue and grooved edge will adhere to and bond with the plastic material of which the board is made and will set in place maintaining the tongue and grooved edge which is formed in the board.

The plastic material 8 is applied to the lower cover sheet at a slight distance in advance of the board forming roller 4, but not sufficiently close to the edging devices 11 and 12 so that the plastic material will engage the edging devices, as they would quickly become obstructed and clogged by the plastic material which would harden thereon and set, and interfere with the operation of the edging devices.

In operating this board forming apparatus, one end of the bottom sheet 1 is threaded through the folding members 10, the edging devices in their open position, and past the edging supports 26 and 27 under the board forming roller 4; the edging devices are then closed by operating the members 16 and the plastic material 8 is deposited upon the cover sheet 1; and the top cover sheet is applied by the forming roll 4 in a well known manner. The bottom cover sheet 1 is drawn through the folders and edge formers by means of the board forming machine so that in reality the edges are formed by pulling the paper or sheet through the edging devices.

We claim:

1. In plaster wallboard apparatus, means for advancing a continuous cover sheet, edge forming devices for engaging the margins only of the cover sheet as it advances, said edging devices comprising means for first folding over the margin of the sheet inwardly, contact plates engaging the folded edge on the inside and outside and continuously crimping and reducing the height of the folded edge as it passes along, and means for maintaining the folded edge after it is formed.

2. In plaster wallboard apparatus an edge

forming device comprising a fixed member and a movable bar, folding plates carried by the members and the bar, said plates being designed to engage the opposite faces of a fibrous cover sheet to impart thereto an increasingly deepening fold as the fibrous cover sheet is drawn therethrough between the plates.

3. In plaster walboard apparatus, an edge forming device comprising a fixed member and a movable bar, folding plates carried by the member and the bar, said plates gradually increasing in width and approaching one another at one end so that a sheet of fibrous material engaged thereby will be folded with an increasing crimp which decreases in height as the material is drawn there-through.

4. In plaster wallboard apparatus an edge folding device which comprises a fixed member and a movable bar, means for adjusting the bar with respect to the member, and creasing devices carried by the member and the bar for imparting a crease to the edge of a fibrous sheet passed therebetween, the arrangement being such that the crease is deepened but the edge is decreased in height as the material is drawn through the edging device.

5. In a plaster wallboard edging device, a fixed member and a movable bar, co-operating edge forming devices carried by the member and bar, means carried by the member to support the bar in an overhanging position with respect to the member, and

means for adjusting the spacing of the bar with respect to the member.

6. In a plaster wallboard edging device, a fixed member and a movable bar, means carried by the member and bar for forming a fold in a fibrous cover sheet as it is drawn therethrough between the member and bar; means for mounting the bar on the member to slide inwardly therefrom, an operating member for moving the bar with respect to the member, and means forming an adjustment to vary the movement of the bar with respect to the member.

7. In a plaster wallboard edging device, a fixed member and a movable bar, co-operating means carried by the member and bar for forming a folded edge as a fibrous sheet is drawn therethrough, adjustable means for mounting the bar to slide to and from the member, said means comprising a shaft, an operating member mounted on the shaft, a short arm mounted on the shaft, and a link suitably connected at one end through the short arm and at the other end having a pivoted connection with the movable bar, the arrangement being such that the axis of the shaft is on a line below the line joining the two pivoted points at the end of the link so that the axis of the operating shaft passes over the line of centers between the ends of the link thereby holding the said bar firmly in any adjusted operating position with respect to the member.

HARRY E. BROOKBY.
CARL ABSMEIER.