

June 8, 1937.

I. L. WILCOX

2,082,995

CONTAINER

Filed June 27, 1936

3 Sheets-Sheet 1

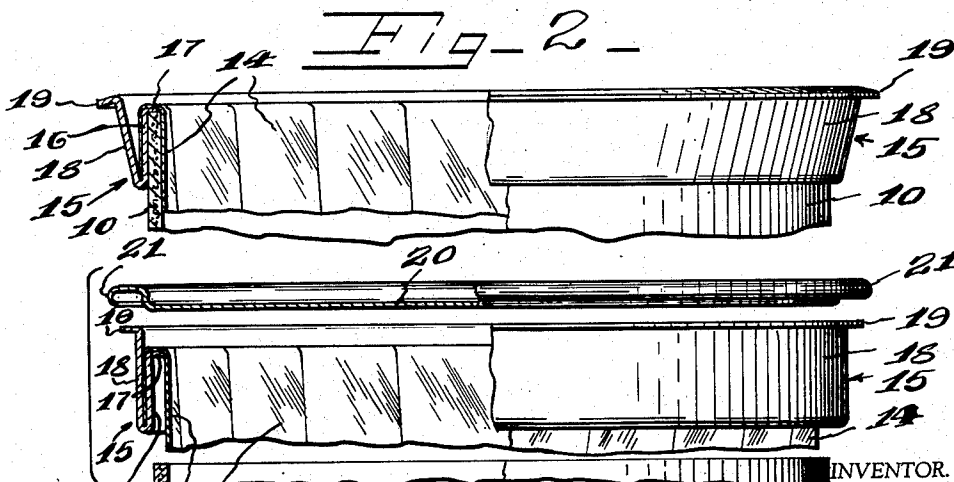
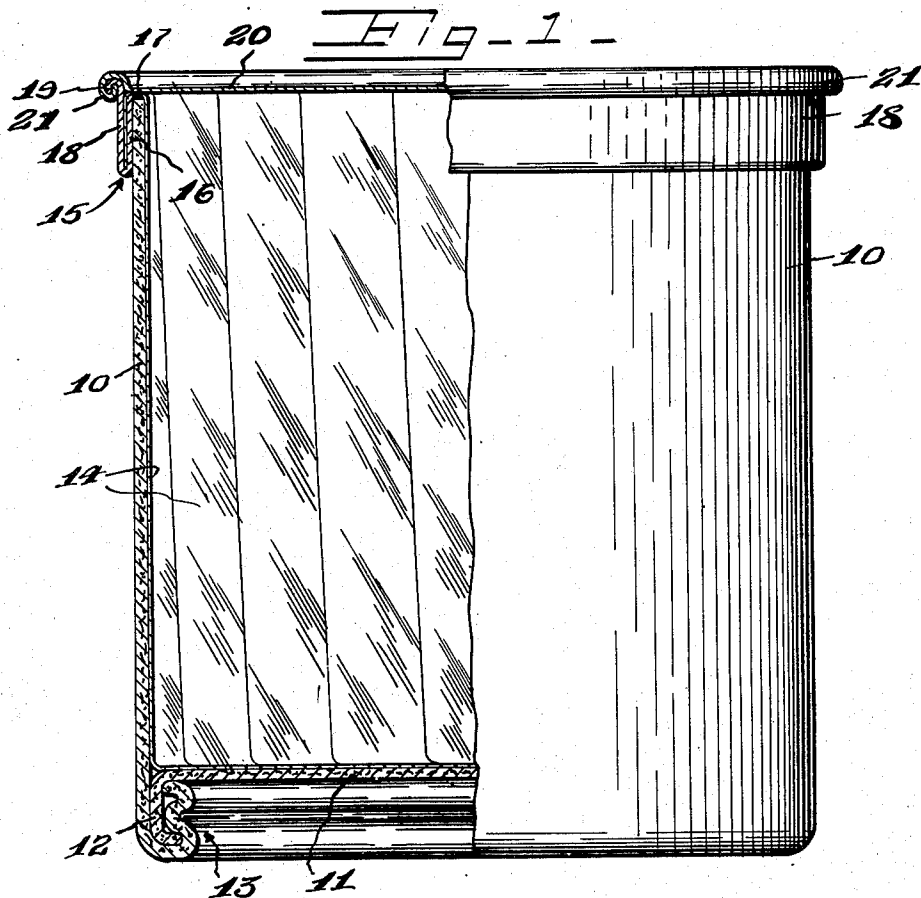

INVENTOR.
I. L. Wilcox
BY
Bridell & Thompson
ATTORNEYS.

June 8, 1937.

I. L. WILCOX

2,082,995

CONTAINER

Filed June 27, 1936

3 Sheets-Sheet 2

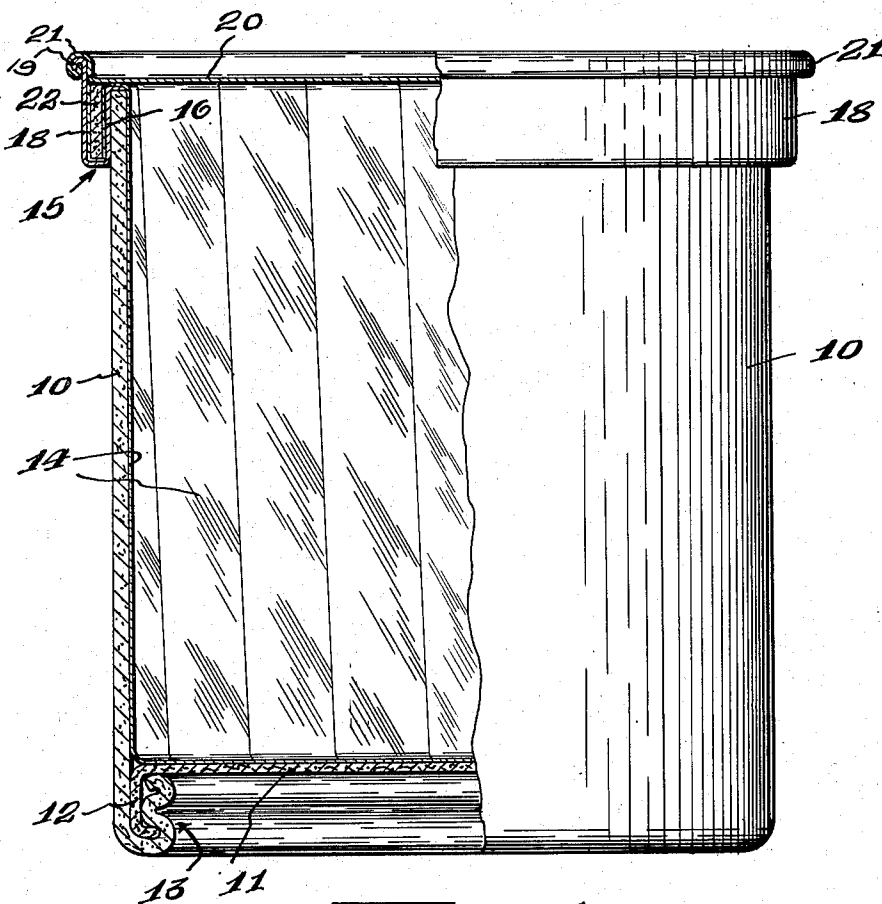

Fig - 4 -

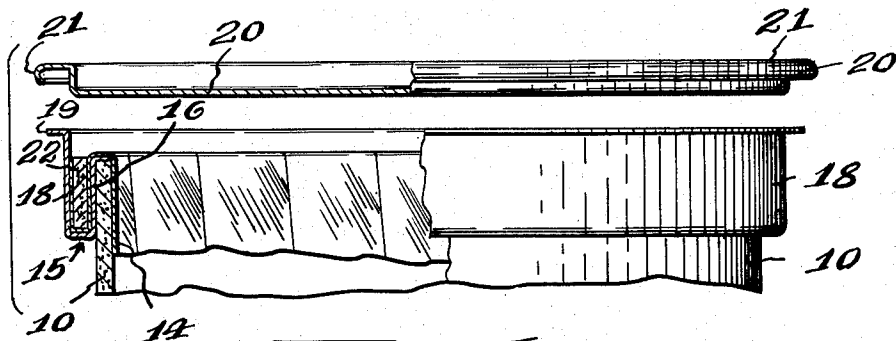

Fig - 5 -

INVENTOR.
Isaac L. Wilcox.
BY *Rodell & Thompson*
ATTORNEYS.

June 8, 1937.

I. L. WILCOX

2,082,995

CONTAINER

Filed June 27, 1936

3 Sheets-Sheet 3

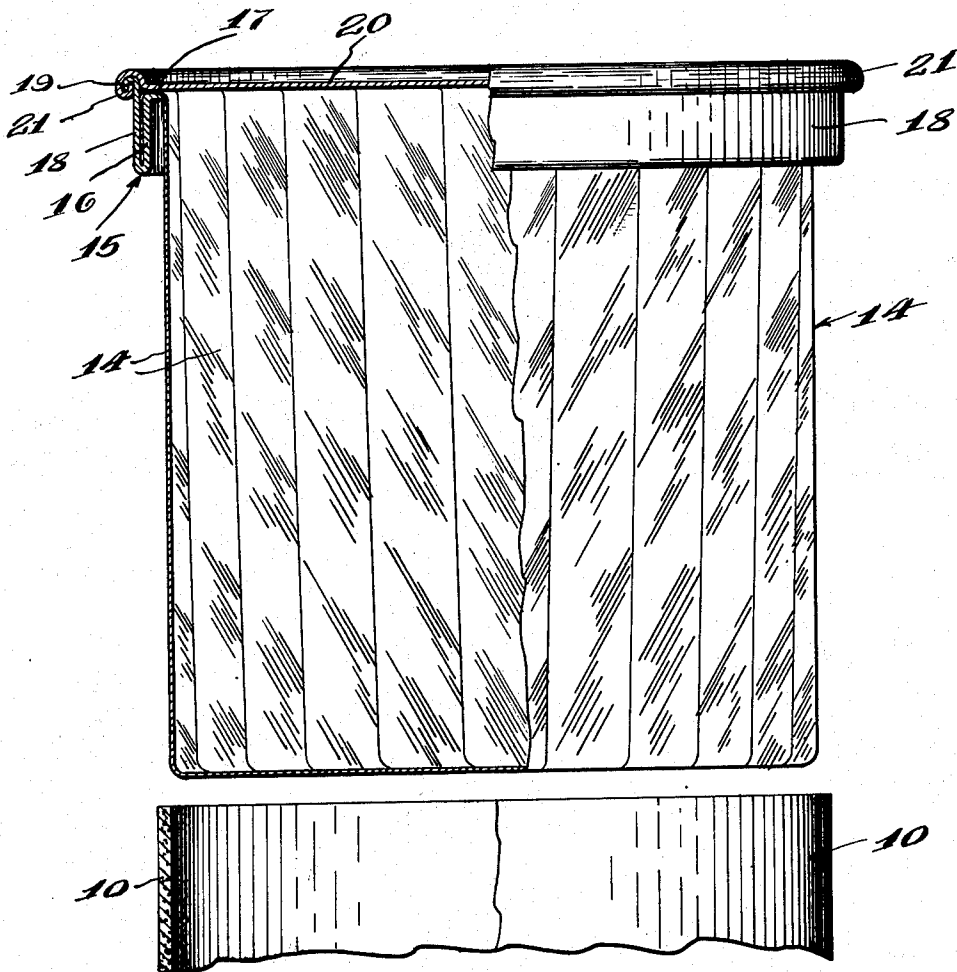

Fig-6

INVENTOR.

BY

I. L. Wilcox
Bodell & Thompson
ATTORNEYS.

UNITED STATES PATENT OFFICE

2,082,995

CONTAINER

Isaac L. Wilcox, Fulton, N. Y., assignor to Oswego Falls Corporation, Fulton, N. Y., a corporation of New York

Application June 27, 1936, Serial No. 87,753

9 Claims. (Cl. 229-14)

This invention relates to containers formed with a casing or body of fibrous material, such as paper board, and an inner liner bag of thin, flexible material, such as cellophane, and more specifically relates to a top structure by which the liner bag is frictionally secured in the casing both before and after the contents has been placed in the container.

The invention has as an object, a container of the type referred to embodying a structure by which the liner bag is frictionally secured to the casing in a manner that adds to the rigidity of the container and also permits the use of a metallic closure which is sealed to the container or bag by a metal to metal joint.

The invention consists in the novel features and in the combinations and constructions hereinafter set forth and claimed.

In describing this invention, reference is had to the accompanying drawings in which like characters designate corresponding parts in all the views.

Figure 1 is a side, elevational view, partly in longitudinal section, of a container embodying the invention.

Figure 2 is a fragmentary, elevational view of the upper end of the container previous to the sealing of the liner bag to its supporting member, and the sealing of the cover to the same.

Figure 3 is a fragmentary side elevational view of the upper portion of the container, with the liner bag and its supporting member partially removed from the casing, and the cover closure to be sealed to the bag supporting member.

Figure 4 is a view, similar to Figure 1, illustrating a modified form of structure.

Figure 5 is a view, similar to Figure 2, with the bag attached to its supporting member, and the top closure unattached.

Figure 6 is an enlarged, elevational view partly in section of the top portion of the container with the sealed liner bag removed.

The invention comprises generally, a container including a casing of fibrous material provided with a suitable bottom closure, a ring member encircling the upper end of the casing and overlapping the upper edge thereof and being folded upon itself to form an upwardly facing channel, a bag of thin, flexible material arranged in the casing with the open end of the bag extending into said channel and being secured thereto, and a top closure for the container secured at its periphery to the ring member.

The body or casing 10 is preferably formed of fibrous material, such as heavy paper board, and

is provided with a bottom closure 11 secured to the casing in any suitable manner. As here shown, the bottom 11 is formed with a depending flange 12, and the lower end of the casing is crimped inwardly against the flange 12, as at 13.

In order that the container may be suitable for use with liquid, or semi-liquid, products or those requiring a gas tight container, a bag 14 of thin, flexible material is arranged in the casing 10. The bag 14 may be formed of cellophane, or like material, which may have the qualities of being liquid and gas tight and preferably transparent.

The container herein referred to is of the type where the top closure is sealed to the bag, and the bag and top closure are removable as a unit from the casing in order that the contents of the bag may be inspected without unsealing the bag. With most materials, from which the bag 14 may be suitably made, it is difficult to effect a proper seal between the open end of the bag and the top closure, if the top closure is formed of the same or similar material, particularly where the container is to be used in connection with merchandise generating gases over pressure, such as coffee. It is also difficult to effect such a seal between the bag 14 and a metallic top closure. It is well known that cellophane, and like materials, are exceedingly thin and accordingly, it is difficult to obtain a joint by crimping the cellophane and metal together which will withstand gas under pressure. The object of this invention is to overcome these difficulties, and structure is provided for detachably supporting the bag in the casing 10, and by such structure the open end of the bag is conveniently secured to its supporting member in gas tight relation thereto, the supporting member being metallic and permitting the use of a metallic cover or top closure which is sealed to the metallic bag support in the conventional manner in which the top is secured to an ordinary tin can.

The bag 14 is detachably supported in the casing 10 by a ring member designated generally at 15. The ring member 15 is folded upon itself to form an upwardly facing channel, the inner side 16 frictionally encircling the upper end of the casing 10 and being formed with an inwardly extending flange 17 overlapping the upper edge of the casing. The outer side 18 of the channel extends upwardly beyond the plane of the flange 17, and is initially formed with a short radial flange 19. The ring member 15 is formed with the outer side wall 18 of the channel flaring out-

wardly, as indicated in Figure 2, and the open end of the bag 14 extends over the flange 17 and into the channel. A suitable adhesive may be applied to the open end of the bag, or in the channel, to effectively seal it to the ring member. However, due partially to the comparatively great depth of the channel, the open end of the bag is effectively sealed thereto by bending or crimping in the outer wall 18 and clamping the end of the bag between it and the inner wall 16, as indicated to the left in Figure 1.

The top closure for the container or bag may be metallic and in form general to the covers or top closures now employed to seal ordinary tin cans. The top closure consists of a discoidal portion 20 formed with an outwardly flaring marginal flange 21. After the contents have been placed in the bag 14, the top closure is applied, and the flanges 19, 21, are crimped together in the conventional manner, and as illustrated in Figure 1. This effects a metal to metal seal between the top closure and the bag or ring member 15.

The ring member 15 acts as a supporting member for the bag 14, and also as a means of retaining the bag in the casing during shipment, and until the bag is filled. It also acts to stiffen the container and make it more rigid. After the top closure is sealed to the outer side of the channel member, the bag ring member 15 and top closure may be conveniently removed from the container, as illustrated in Figure 6, to permit inspection of the contents of the bag, and during this operation the metallic ring member 15 and metallic top closure act as a rigid support for the bag.

In Figures 4 and 5, the ring member 15 is formed with a wider channel, with the inner and outer walls 16, 18, extending in parallel relationship. In this structure, the open end of the bag 14 is secured in the channel by a wedge member 22 preferably of fibrous material, such as paper board.

With the structure shown in Figures 1 to 3, there may be instances where it is necessary to secure the open end of the bag in the channel by performing the crimping or bending operation previous to the insertion of the bag into the container. With the construction shown in Figures 4 and 5, the bag may be formed and inserted in the container with the open end of the bag extending over the channel. The wedge ring member 22 may be then pressed downwardly into the channel, drawing the open end of the bag with it and sealing the open end of the bag in the channel.

What I claim is:

1. A container comprising a cylindrical casing provided with a bottom closure, a ring member encircling the upper portion of the casing and being folded upon itself to form an upwardly facing channel, a bag of thin, flexible material arranged in the casing with the open end of the bag extending into said channel and being secured thereto, and a top closure for the container having its periphery secured to said ring.

2. A container comprising a cylindrical casing provided with a bottom closure, a metallic ring encircling the upper portion of the casing and being frictionally secured thereto, said ring being folded upon itself to form an upwardly facing channel, a bag of thin, flexible material arranged in the casing with the open end of the bag extending into said channel and being secured

thereto, and a top closure for the container having its periphery secured to said ring.

3. A container comprising a cylindrical casing provided with a bottom closure, a metallic ring encircling the upper portion of the casing and being frictionally secured thereto, said ring being folded upon itself to form an upwardly facing channel with the outer side of the channel extending upwardly beyond the top edge of the container, a bag of thin, flexible material arranged in the container with the open end of the bag extending into said channel and being secured thereto, and a top closure for the container having its periphery secured to the outer side member of the channel.

4. A container comprising a cylindrical casing provided with a bottom closure, a metallic ring folded upon itself to form an upwardly facing channel with the inner side of said channel encircling the upper portion of the casing and having an inwardly extending flange overlapping the upper edge of the casing, and the outer side of the channel projecting upwardly beyond the flange of the inner side of the channel, a bag of thin, flexible material arranged in the container with the open end of the bag extending over said flange into said channel and being secured to the ring member, and a top closure for the container being secured at its periphery to said outer side member of the channel.

5. A container comprising a cylindrical casing provided with a bottom closure, a ring member encircling the upper portion of the casing and being folded upon itself to form an upwardly facing channel, a bag of thin, flexible material arranged in the container with the open end of the bag extending into said channel, a ring located in said channel and coacting with the open end of the bag to secure it in the channel, and a cover closure for the container being secured at its periphery to said ring member.

6. A container comprising a cylindrical casing provided with a bottom closure, a metallic ring member encircling the upper end of the casing and overlapping the upper edge thereof and being folded upon itself to form an upwardly facing channel, a bag of thin, flexible material arranged in the casing with the open end of the bag extending into said channel, a wedge member of fibrous material arranged in said channel and being cooperable with the open end of the bag to secure the same in the channel, and a top closure for the container being secured at its periphery to said ring member.

7. A container comprising a cylindrical casing provided with a bottom closure, a metallic ring member encircling the upper end of the casing and overlapping the upper edge thereof and being folded upon itself to form an upwardly facing channel, a bag of thin, flexible material arranged in the casing with the open end of the bag extending into said channel, a wedge member of fibrous material arranged in the channel and being cooperable with said bag to secure the open end thereof in the channel, a top closure for the container being secured at its periphery to said ring member, and said ring member frictionally engaging the upper end of the casing, whereby said ring member, bag, and top closure, may be removed from the casing as a unit.

8. A container comprising a cylindrical casing provided with a bottom closure, a metallic ring encircling the upper portion of the casing and being folded upon itself to form an upwardly facing channel with the outer side member of said

channel being formed with an outwardly flaring
flange, a bag of thin, flexible material arranged
in the casing with the open end of the bag ex-
tending into said channel and being secured
thereto, and a top closure for the container hav-
ing its periphery secured to said flange.

9. A container comprising a cylindrical casing
provided with a bottom closure, a metallic ring
encircling the upper portion of the casing and
being folded upon itself to form an upwardly fac-
ing channel, the inner side member of said chan-

nel being provided with an inwardly extending
flange overlapping the upper edge of the casing,
and the outer side member being provided with
an outwardly flaring flange, a bag of thin, flexible
material arranged within the casing with the
open end of the bag extending into said channel
and being secured thereto, and a top closure for
the container having its periphery secured to said
ring.

ISAAC L. WILCOX. 10