

P. G. EMERY.
WINDOW SHADE.

APPLICATION FILED OCT. 3, 1900.

NO MODEL.

2 SHEETS—SHEET 1.

Fig. 1.

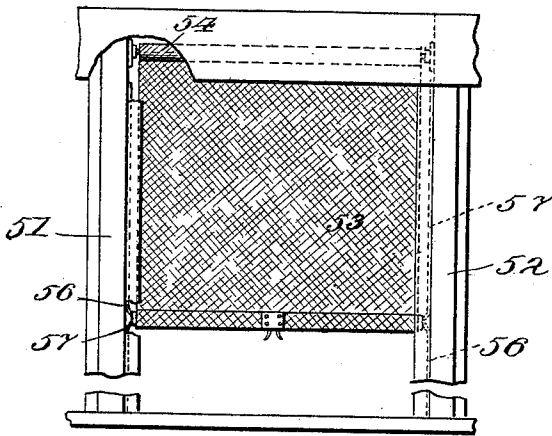

Fig. 3.

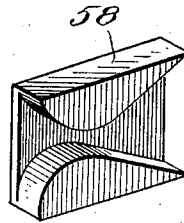

Fig. 2.

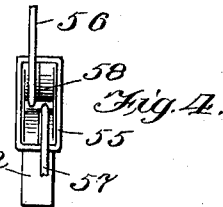
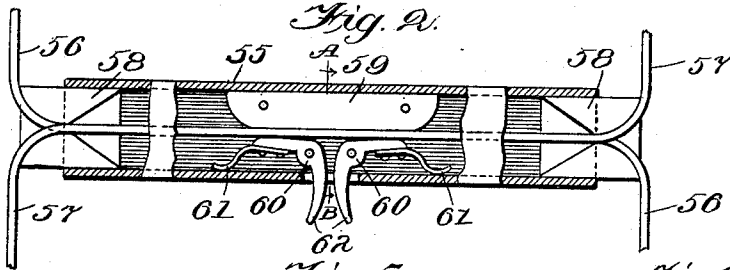

Fig. 5.

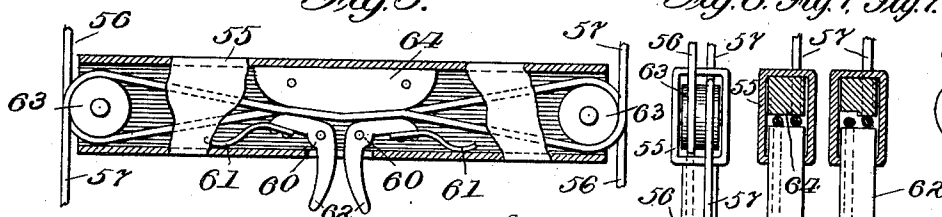

Fig. 6. Fig. 7. Fig. 7a.

Fig. 8.

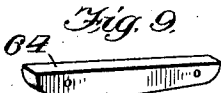
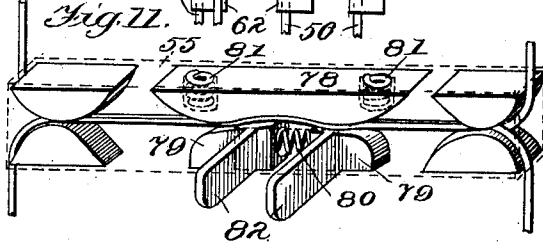
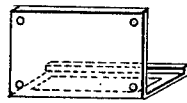

Fig. 10.



Witnesses:
H. S. Gaitler
K. L. Peck

Inventor:
Plato G. Emery
 by *Wm. A. Bell*
 Attorney

No. 718,992.

PATENTED JAN. 27, 1903.

P. G. EMERY.
WINDOW SHADE.

APPLICATION FILED OCT. 3, 1900.

NO MODEL.

2 SHEETS—SHEET 2.

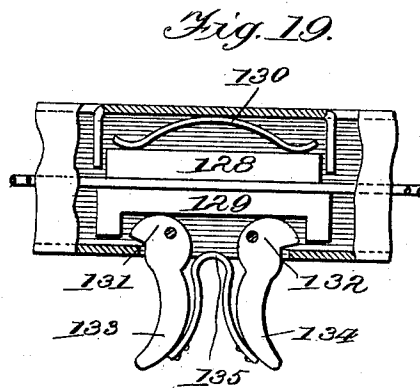
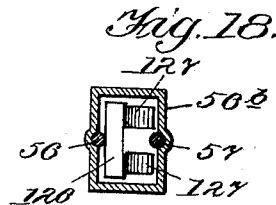
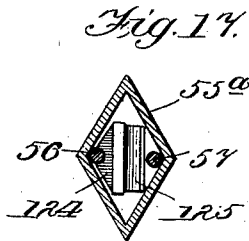
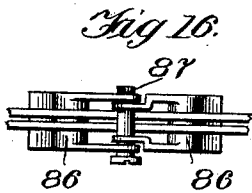
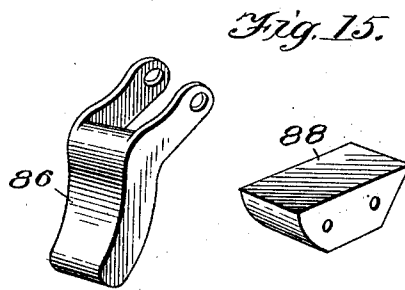
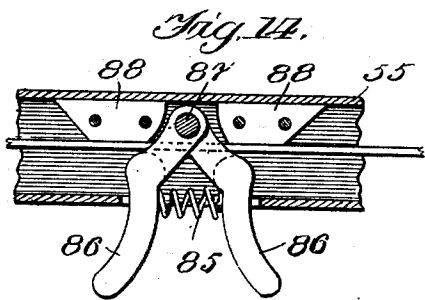
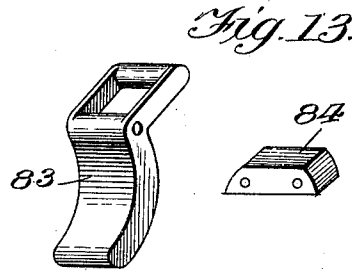
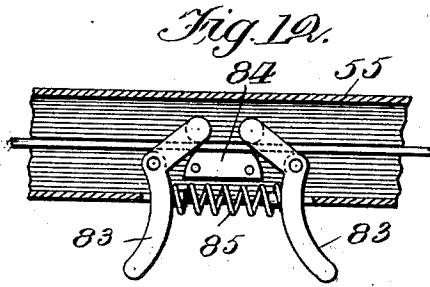

Witnesses:
H. S. Gaiter
Helen L. Peck

Inventor:
Plato G. Emery
Wm. O. Bell
 Attorney.

UNITED STATES PATENT OFFICE.

PLATO G. EMERY, OF CHICAGO, ILLINOIS.

WINDOW-SHADE.

SPECIFICATION forming part of Letters Patent No. 718,992, dated January 27, 1903.

Application filed October 3, 1900. Serial No. 31,895. (No model.)

To all whom it may concern:

Be it known that I, PLATO G. EMERY, a citizen of the United States of America, and a resident of Chicago, county of Cook, and State of Illinois, have invented certain new and useful Improvements in Window-Shades, of which the following is a specification, and which are illustrated in the accompanying drawings, forming a part thereof.

This improvement relates to that type of window-shades ordinarily used in car service in which a curtain of fabric is carried by a spring-roller and is provided with a tubular curtain-rod at its lower end through which pass a pair of "squaring-cords," each of the cords being fastened at the top of one of the window-stiles and at the bottom of the other. For the purpose of this invention each cord runs from the upper corner of one stile through the curtain-rod to the lower corner of the other stile, and whether it runs farther or not is immaterial.

The objects of the invention are to provide improved means for frictionally engaging the curtain with the cords, so as to hold it against the tension of the spring and to otherwise improve the construction of shades of this type.

The invention consists in the construction hereinafter described, and which is illustrated in the accompanying drawings, in which—

Figure 1 is a detail front elevation of a window-frame equipped with my improved shade, some of the parts being broken away. Fig. 2 is a longitudinal section, partly in elevation, of a tubular curtain-rod, showing a detail of the cords passing therethrough. Fig. 3 is a perspective of a guide-block fitted within the end of the rod. Fig. 4 is an end elevation of the rod with the cords issuing therefrom. Fig. 5 is a longitudinal section of the curtain-rod, partly in elevation, showing a modified construction. Fig. 6 is an end elevation of the same. Fig. 7 is a sectional view on the line A B of Fig. 5. Fig. 7^a is a similar view showing the devices constructed to clamp but one of the cords. Fig. 8 is a perspective of a roller mounted within the tubular rod shown in Fig. 5. Figs. 9 and 10 are details in perspective of various parts of the structure shown in Fig. 5. Fig. 11 is a detail of a modified form of friction mechanism, its relation to the curtain-rod being shown in dotted

lines. Fig. 12 is a detail longitudinal section of a curtain-rod, showing a modified form of the friction device. Fig. 13 shows details of parts of the structure illustrated in Fig. 12. Fig. 14 is a detail longitudinal section of a curtain-rod, showing a somewhat different form of friction device. Fig. 15 illustrates details of the construction shown in Fig. 14. Fig. 16 is a detail plan of the friction mechanism illustrated in Fig. 14. Figs. 17 and 18 are transverse sections of the curtain-rod, showing various forms of cord-clamps. Fig. 19 is a detail of the curtain-rod, partly in elevation and partly in section, showing another form of clamping-blocks for the cords.

The window-frame illustrated in the drawings has a sill 50 and side stiles 51 and 52. The curtain is shown at 53 and is wound upon a spring-roller 54 and at its lower end is provided with a tubular rod 55. The so-called "squaring-cords" 56 57 are secured to the stiles, the cord 56 being secured at its upper end to the stile 51 and at its lower end to the stile 52 and the cord 57 being secured at its upper end to the stile 52 and at its lower end to the stile 51, both cords passing through the bore of the rod. Heretofore it has been the practice to draw the cords, as 56 57, quite taut, so that they will bind in the ends of the rod, thereby producing the necessary friction to hold the curtain against the tension of the spring of the roller upon which it is wound. The parts already described differ from this practice only in that the cords may be as loose as may be desired, thereby materially reducing the wear of the parts. A guide is fixed within each end of the rod 55 and in Fig. 2 is shown made of a pair of blocks 58, grooved in their contacting faces so as together to form an aperture through which the cords 56 57 pass, the outer portion of such aperture being rounded, so as to slide freely upon the cords.

Midway of the ends of the rod 55 is fixed a friction-block 59, and cooperating therewith are a pair of levers 60, pivoted within the rod, one of their ends being adapted to clamp the cords against the block 59, a spring 61 normally holding the parts in this position, and the opposite ends 62 of the levers extending through a suitable aperture in the rod, so that they may be grasped between

the thumb and finger of the operator to draw them together, and thereby force downwardly the inner ends of the levers against the resistance of the springs 61, thereby releasing the cords. By this means the cords are clamped with sufficient grip to prevent them from running through the tubular rod to allow the curtain to move up or down until the levers are purposely released, when the shade may be freely moved.

In the construction of Figs. 5 to 10 there is substituted for the guide-blocks 58 a guide in the form of a roller 63, journaled within each end of the rod 55, each of the cords passing under one of these rollers and over the other. There is substituted for the friction-block 59 a similar block 64, having, however, its lower face inclined upwardly in each direction from its middle portion, so that the inner arms of the levers 60 have a longer bearing against it when forced upwardly by the springs 61.

In the construction of Fig. 11 the releasable friction upon the cords is secured by mounting a block 78 within the rod 55, this block having its inner face, which is adapted for contact with the cords, inclined inwardly from its ends. A pair of movable clamping-blocks 79, having inclined faces for cooperating with the inclined faces of the block 78, are spread apart by an expansion-spring 80, interposed between them, so that they clamp the cords against the block 78 by a wedge action. The block 78 is preferably seated against a pair of springs 81, so that it will yield somewhat to the pressure of the block 79. Each of the latter blocks is provided with a stem 82, by which it may be manually controlled.

In the constructions of Figs. 12 and 13 and 14 to 16 the releasable clamping is accomplished by levers in loop form, through which the cords pass. In the construction of Figs. 12 and 13 these loop forms of levers 83 are pivoted below the cords, so that their loop portions are above their pivots. A fixed clamping-block 84 is located below the cords, and an expansion-spring 85 reacting between the two levers below their pivots throws the transverse portion of the loop of each downwardly, so as to clamp the cords against the upper face of the block 84. In the construction of Figs. 14 to 16 such loop-levers 86 are pivoted above the cords by means of a single pivot 87. In this instance a pair of clamping-blocks 88 is fixed within the rod 55, one upon each side of the pivot 87 and both of them above the cords. The spring 85 by separating the lower ends of the levers 86 causes the clamping of the cords between the body portions of the levers and the blocks 88.

Preferably friction is applied to both of the cords; but it may be applied to but one of the cords, and forms of construction whereby this is accomplished are shown in Figs. 17 and 18.

In the construction of Fig. 17 a hollow cur-

tain-rod 55^a is shown as diamond-shaped in cross-section. The two cords 56 57 run in opposite angles of the rod, and one of them is clamped by a block 124, controlled by a leaf-spring 125, while the other runs freely in the triangular space back of the spring, which reacts against adjacent sides of the rod.

The construction of Fig. 18 is substantially the same as that of Fig. 17, except that the hollow rod 56^b is rectangular in cross-section, and channels are formed in two of its opposite walls for the cords 56 57, one of these channels being shallow, so that a clamping-block 126 may bear upon the cord, being controlled by a leaf-spring 127, while the other channel is sufficiently deep to allow the cord to run freely within it.

In the construction of Fig. 19 clamping blocks or plates 128 129 are housed within the hollow rod, one being controlled by a spring 130 and the other by a pair of eccentrics 131 132, pivoted within the rod, and each having a swell adapted to bear against the block 129. Each cam is provided with a stem 133 134, and a spring 135 reacts between the two stems, so as to spread them, thereby forcing the swell of the cams against the block and clamping the squaring-cords. The stems 133 134 also constitute finger-pieces, by means of which the pressure upon the squaring-cords may be released by the compression of the spring 135.

I claim as my invention—

1. The combination with a curtain having a constant upward tendency, of a hollow rod at the end of the curtain, squaring-cords attached to the window-casing and passing through the rod, and a lever device carried by the curtain for frictionally clamping one of the cords intermediate of the ends of the rod.

2. The combination with a curtain having a constant upward tendency, of a hollow rod at the end of the curtain, squaring-cords attached to the window-casing and passing through the rod, and pivoted means carried by the curtain for frictionally clamping one of the cords intermediate of the ends of the rod.

3. The combination with a curtain having a constant upward tendency, of a hollow rod at the end of the curtain, squaring-cords attached to the window-casing and passing through the rod, and spring-pressed releasable means carried by the curtain for frictionally engaging one of the cords.

4. The combination with a curtain having a constant upward tendency, of a hollow rod at the end of the curtain, squaring-cords attached to the window-casing and passing through the rod, and a yielding clamping device intermediate of the ends of the rod for engaging and clamping one of the cords to hold the curtain against its upward tendency.

5. The combination with a curtain having a constant upward tendency, of a hollow rod at the end of the curtain, squaring-cords at-

tached to the window-casing and passing through the rod, and spring-pressed releasable means carried by the curtain for frictionally engaging both of the cords.

5 6. The combination with a curtain having a constant upward tendency, of a hollow rod at the end of the curtain, squaring-cords attached to the window-casing and passing through the rod, and a yielding clamping device intermediate of the ends of the rod for engaging and clamping both of the cords to hold the curtain against its upward tendency.

15 7. The combination with a curtain having a constant upward tendency, of a hollow rod at the end of the curtain, squaring-cords attached to the window-casing and passing through the rod, and a spring-pressed device intermediate of the ends of the rod normally acting on one of the cords to hold the curtain against its upward tendency.

20 8. The combination with a curtain having a constant upward tendency, of a hollow rod at the end of the curtain, squaring-cords attached to the window-casing and passing through the rod, guides for said cord at the ends of the rod, and a yielding clamping device between the guides for engaging and clamping one of the cords to hold the curtain against its upward tendency.

30 9. The combination with a curtain having a constant upward tendency, of a hollow rod at the end of the curtain, squaring-cords attached to the window-casing and passing through the rod, guides for the cord at the ends of the rod, and a spring-pressed clamping device located between the guides for engaging and clamping one of the cords to hold the curtain against its upward tendency.

35 10. The combination with a curtain having a constant upward tendency, of a hollow rod at the end of the curtain, squaring-cords attached to the window-casing and passing through the rod, a yielding device for engaging and clamping one of the cords to hold the curtain against its upward tendency, and guide-blocks at the ends of the rod provided with apertures having a rounded outer portion to receive the cord.

40 11. The combination with a curtain having a constant upward tendency, of a hollow rod at the end of the curtain, squaring-cords attached to the window-casing and passing through the rod, a yielding device for engaging and clamping one of the cords to hold the curtain against its upward tendency, and a guide for the cord at each end of the rod consisting of a pair of blocks provided with an aperture

to receive the cords and having a rounded outer portion over which the cords travel.

12. The combination with a curtain having 60 a constant upward tendency, of a hollow rod at the end of the curtain, squaring-cords attached to the window-casing and passing through the rod, a guide at each end of the rod provided with a rounded surface over which 65 the cords travel, and a pair of spring-pressed levers normally engaging one of the cords to hold the curtain against its upward tendency and projecting through an opening in the rod, so that they can be compressed to release the 70 cord or cords.

13. The combination with a curtain having a constant upward tendency, of a hollow rod at the end of the curtain, squaring-cords attached to the window-casing and passing 75 through the rod, and a pair of spring-pressed levers normally engaging the cord within the rod and projecting through an opening in the rod, so that they can be compressed to release the cord. 80

14. The combination with a curtain having a constant upward tendency, of a hollow rod at the end of the curtain, squaring-cords attached to the window-casing and passing 85 through the rod, a friction-block located within the rod between its ends, and a clamping device yieldingly engaging one of said cords and normally clamping same against the friction-block to hold the curtain against its upward tendency. 90

15. The combination with a curtain having a constant upward tendency, of a hollow rod at the end of the curtain, squaring-cords attached to the window-casing and passing 95 through the rod, guides for the cords at each end of the rod, a friction-block located within the rod and between the guides, and a spring-pressed device normally engaging one of the cords and clamping same against the friction-block to hold the curtain against its upward 100 tendency.

16. The combination with a curtain having a constant upward tendency, of a hollow rod at the lower margin of the curtain, squaring-cords attached to the window-casing and pass- 105 ing through the rod, and a spring-pressed device for clamping one of the cords and provided with a handle projecting through an opening in the rod and adapted to be operated to release the cord.

PLATO G. EMERY.

Witnesses:

LOUIS K. GILLSON,
E. M. KLATCHER.