



- (51) **International Patent Classification:**  
G06F 1/16 (2006.01)
- (21) **International Application Number:**  
PCT/US2019/060934
- (22) **International Filing Date:**  
12 November 2019 (12.11.2019)
- (25) **Filing Language:** English
- (26) **Publication Language:** English
- (30) **Priority Data:**  
16/218,234 12 December 2018 (12.12.2018) US
- (71) **Applicant: DELL PRODUCTS, L.P.** [US/US]; One Dell Way, Round Rock, Texas 78682 (US).
- (72) **Inventors: KNOPPERT, Michiel Sebastiaan Emanuel Petrus;** JF van Hengelstraat 32, 1019 DC Amsterdam (NL). **LIGAMERI, Mark R.;** 33 Pontchatrain North, Santa Rosa, Florida 32459 (US).
- (74) **Agent: VON PAUMGARTTEN, Luiz et al.;** Fogarty LLP, P.O. Box 703695, Dallas, Texas 75370-3695 (US).

HR, HU, ID, IL, IN, IR, IS, JO, JP, KE, KG, KH, KN, KP, KR, KW, KZ, LA, LC, LK, LR, LS, LU, LY, MA, MD, ME, MG, MK, MN, MW, MX, MY, MZ, NA, NG, NI, NO, NZ, OM, PA, PE, PG, PH, PL, PT, QA, RO, RS, RU, RW, SA, SC, SD, SE, SG, SK, SL, SM, ST, SV, SY, TH, TJ, TM, TN, TR, TT, TZ, UA, UG, US, UZ, VC, VN, ZA, ZM, ZW.

(84) **Designated States** (unless otherwise indicated, for every kind of regional protection available): ARIPO (BW, GH, GM, KE, LR, LS, MW, MZ, NA, RW, SD, SL, ST, SZ, TZ, UG, ZM, ZW), Eurasian (AM, AZ, BY, KG, KZ, RU, TJ, TM), European (AL, AT, BE, BG, CH, CY, CZ, DE, DK, EE, ES, FI, FR, GB, GR, HR, HU, IE, IS, IT, LT, LU, LV, MC, MK, MT, NL, NO, PL, PT, RO, RS, SE, SI, SK, SM, TR), OAPI (BF, BJ, CF, CG, CI, CM, GA, GN, GQ, GW, KM, ML, MR, NE, SN, TD, TG).

**Published:**  
— with international search report (Art. 21(3))

- (81) **Designated States** (unless otherwise indicated, for every kind of national protection available): AE, AG, AL, AM, AO, AT, AU, AZ, BA, BB, BG, BH, BN, BR, BW, BY, BZ, CA, CH, CL, CN, CO, CR, CU, CZ, DE, DJ, DK, DM, DO, DZ, EC, EE, EG, ES, FI, GB, GD, GE, GH, GM, GT, HN,

(54) **Title:** DOCK FOR A MULTI-FORM FACTOR INFORMATION HANDLING SYSTEM (IHS)

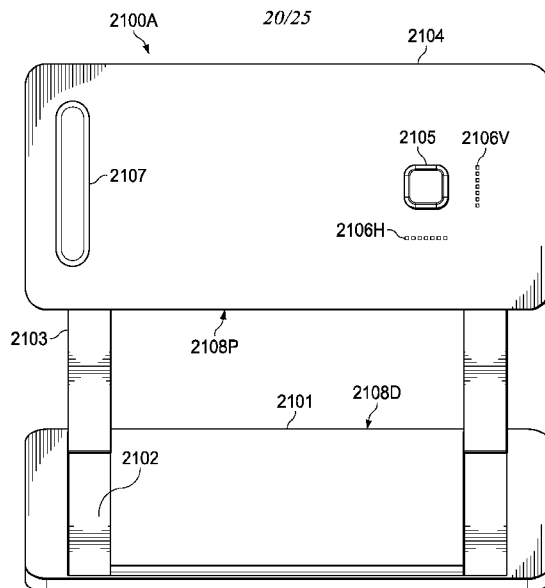

FIG. 21A

(57) **Abstract:** Embodiments of a dock for a multi-form factor Information Handling System (IHS) are described. In an illustrative, non-limiting embodiment, a dock may include: a base, a plateau configured to receive an IHS, and an arm coupling a distal edge of the base to a proximal edge of the plateau, where the arm rotates with respect to the base around a first axis to lift the plateau, where the plateau rotates with respect to the arm around a second axis to tilt the plateau, and where the second axis is parallel with respect to the first axis.

WO 2020/123075 A1

**DOCK FOR A MULTI-FORM FACTOR INFORMATION HANDLING SYSTEM (IHS)**Field

[0001] This disclosure relates generally to Information Handling Systems (IHSs), and more specifically, to a dock for a multi-form factor IHS.

5 Background

[0002] As the value and use of information continues to increase, individuals and businesses seek additional ways to process and store information. One option available to users is Information Handling Systems (IHSs). An IHS generally processes, compiles, stores, and/or communicates information or data for business, personal, or other purposes thereby allowing users to take advantage of the value of the information. Because technology and information handling needs and requirements vary between different users or applications, IHSs may also vary regarding what information is handled, how the information is handled, how much information is processed, stored, or communicated, and how quickly and efficiently the information may be processed, stored, or communicated. The variations in IHSs allow for IHSs to be general or configured for a specific user or specific use such as financial transaction processing, airline reservations, enterprise data storage, or global communications. In addition, IHSs may include a variety of hardware and software components that may be configured to process, store, and communicate information and may include one or more computer systems, data storage systems, and networking systems.

20 [0003] Nowadays, users can choose among many different types of mobile IHS devices. Each type of device (e.g., tablets, 2-in-1s, mobile workstations, notebooks, netbooks, ultra-books, etc.) has unique portability, performance, and usability features; however, each also has its own trade-offs and limitations. For example, tablets have less compute power than notebooks and workstations, while notebooks and workstations lack the portability of tablets. A conventional 2-in-1 device combines the portability of a tablet with the performance of a notebook, but with a small display—an uncomfortable form factor in many use-cases.

[0004] The inventors hereof have determined that, as productivity continues to be a core tenet of modern computing, mobile IHS devices should provide versatility for many use-cases and display postures in use today (e.g., tablet mode, laptop mode, etc.), as well as future display

postures (e.g., digital notebooks, new work surfaces, etc.). Additionally, mobile IHS devices should provide larger display area with reduced size and weight.

### Summary

5 [0005] Embodiments of systems and methods for a dock for a multi-form factor Information Handling System (IHS) are described. In an illustrative, non-limiting embodiment, a dock may include: a base, a plateau configured to receive an IHS, and an arm coupling a distal edge of the base to a proximal edge of the plateau, where the arm rotates with respect to the base around a first axis to lift the plateau, where the plateau rotates with respect to the arm around a second axis to tilt the plateau, and where the second axis is parallel with respect to the first axis.

10 [0006] In some implementations, the plateau may include a magnetic device. The magnetic device may be positioned in the plateau in a direction perpendicular to the proximal edge of the plateau. The plateau may include a positioning nib. The dock may include first row of terminals disposed in parallel with respect to the proximal edge of the plateau alongside a given edge of the positioning nib. Additionally, or alternatively, a second row of terminals may be  
15 perpendicularly with respect to the first row of terminals alongside another side of the positioning nib. The IHS may also include a first display coupled to a second display via a hinge.

[0007] The second display may include a second magnetic device positioned to mate with the magnetic device and a second positioning nib positioned to mate with the positioning nib in the plateau when the plateau receives the IHS in laptop mode. The first display may include a  
20 third magnetic device positioned to mate with the magnetic device in the plateau when the plateau receives the IHS in dual-display mode in a portrait orientation. The base may also include a graphical processor configured to be coupled to the IHS in response to the IHS being received by the plateau.

[0008] In some cases, the IHS may include: a processor; and a memory coupled to the  
25 processor, the memory having program instructions stored thereon that, upon execution by the processor, cause the IHS to: identify a docking state of the IHS. The program instructions, upon execution by the processor, may also cause the IHS to, based on the identification, produce a corresponding User Interface (UI) feature on the first or second displays. The docking state may be selected from the group consisting of: dual monitor mode, book mode, and laptop mode.

[0009] In another illustrative, non-limiting embodiment, a method, comprise coupling an IHS to a plateau of a dock, where a proximal edge of the plateau is coupled to a distal edge of a base via an arm, where the arm rotates with respect to the base around a first axis to lift the IHS, and where the plateau rotates with respect to the arm around a second axis to tilt the IHS; collapsing the arm into the base to enter a book mode; and extending the arm away from the base to enter a dual monitor mode.

[0010] The plateau may include a magnetic device and a positioning nib. The IHS may include a first display coupled to a second display via a hinge, and the second display may include a second magnetic device positioned to mate with the magnetic device and a second positioning nib positioned to mate with the positioning nib when the IHS is in laptop mode. The first display may include a third magnetic device positioned to mate with the magnetic device when the IHS is in dual-display mode.

[0011] In yet another illustrative, non-limiting embodiment, a hardware memory device may have program instructions stored thereon that, upon execution by a processor of an IHS, cause the IHS to: identify a state of the IHS relative to a dock, wherein the dock further comprises: a base; a plateau configured to receive the IHS; and an arm coupling a distal edge of the base to a proximal edge of the plateau, where the arm rotates with respect to the base around a first axis to lift the plateau, where the plateau rotates with respect to the arm around a second axis to tilt the plateau, and where the second axis is parallel with respect to the first axis; and based on the identification, enable a connector between the plateau and the IHS.

[0012] The plateau may include a magnetic device and a positioning nib, where the IHS further comprises a first display coupled to a second display via a hinge, and where the second display comprises a second magnetic device positioned to mate with the magnetic device and a second positioning nib positioned to mate with the positioning nib when the IHS is in laptop mode. The first display may include a third magnetic device positioned to mate with the magnetic device when the IHS is in dual-display mode.

#### Brief Description of the Drawings

[0013] The present invention(s) is/are illustrated by way of example and is/are not limited by the accompanying figures, in which like references indicate similar elements. Elements in the figures are illustrated for simplicity and clarity and have not necessarily been drawn to scale.

[0014] FIG. 1 is a perspective view of a multi-form factor Information Handling System (IHS) with a removable keyboard, according to some embodiments.

[0015] FIGs. 2 and 3 are block diagrams of components of the multi-form factor IHS and removable keyboard, respectively, according to some embodiments.

5 [0016] FIG. 4 is a block diagram of a multi-form factor configuration engine, according to some embodiments.

[0017] FIG. 5 is a flowchart of a method for configuring multi-form factor IHSs, according to some embodiments.

10 [0018] FIGs. 6A-C, 7A-J, 8A-D, and 9A-F illustrate examples of laptop, tablet, book, and display postures, respectively, according to some embodiments.

[0019] FIGs. 10A-C and 11A-C illustrate various use-cases, according to some embodiments.

[0020] FIGs. 12A-D, 13A, and 13B illustrate a first hinge implementation and a second hinge implementation, respectively, according to some embodiments.

[0021] FIG. 14 illustrates an accessory charging system, according to some embodiments.

15 [0022] FIGs. 15, 16A-C, 17A, and 17B illustrate a third hinge implementation, a fourth hinge implementation, and a fifth hinge implementation, respectively, according to some embodiments.

[0023] FIG. 18A and 18B illustrate a folio case system, according to some embodiments.

[0024] FIG. 19 illustrates an accessory backpack system, according to some embodiments.

20 [0025] FIGs. 20A and 20B are a flowchart of a method for providing context-aware User Interface (UI), according to some embodiments.

[0026] FIGs. 21A-C illustrate a dock in different positions, according to some embodiments.

[0027] FIGs. 22A and 22B illustrate examples of docking and undocking methods, according to some embodiments.

25 [0028] FIGs. 23A-C illustrate docking states of the multi-form factor IHS, according to some embodiments.

## Detailed Description

[0029] To facilitate explanation of the various systems and methods discussed herein, the following description has been split into sections. It should be noted, however, that any sections, headings, and subheadings used herein are for organizational purposes only, and are not meant to limit or otherwise modify the scope of the description nor the claims.

### [0030] Overview

[0031] Embodiments described herein provide systems and methods for a dock for a multi-form factor Information Handling System (IHS). In various implementations, a mobile IHS device may include a dual-display, foldable IHS. Each display may include, for example, a Liquid Crystal Display (LCD), Organic Light-Emitting Diode (OLED), or Active Matrix OLED (AMOLED) panel or film, equipped with a touchscreen configured to receive touch inputs. The dual-display, foldable IHS may be configured by a user in any of a number of display postures, including, but not limited to: laptop, tablet, book, clipboard, stand, tent, and/or display.

[0032] A user may operate the dual-display, foldable IHS in various modes using a virtual, On-Screen Keyboard (OSK), or a removable, physical keyboard. In some use cases, a physical keyboard may be placed atop at least one of the screens to enable use of the IHS as a laptop, with additional User Interface (UI) features (e.g., virtual keys, touch input areas, etc.) made available via the underlying display, around the keyboard. In other use cases, the physical keyboard may be placed in front of the IHS to expose a larger display area. The user may also rotate the dual-display, foldable IHS, to further enable different modalities with the use of the physical keyboard. In some cases, when not in use, the physical keyboard may be placed or stored inside the dual-display, foldable IHS.

[0033] FIG. 1 is a perspective view of multi-form factor IHS 100 with removable keyboard 103. As shown, first display 101 is coupled to second display 102 via hinge 104, and keyboard 103 sits atop second display 102. The current physical arrangement of first display 101 and second display 102 creates a laptop posture, such that first display 101 becomes primary display area 105 presented by IHS 100, where video or display frames may be rendered for viewing by a user.

[0034] In operation, in this particular laptop posture, second display 102 may sit horizontally on a work surface with its display surface facing up, and keyboard 103 may be positioned on top of second display 102, occluding a part of its display surface. In response to this posture and

keyboard position, IHS 100 may dynamically produce a first UI feature in the form of at least one configurable secondary display area 106 (a “ribbon area” or “touch bar”), and/or a second UI feature in the form of at least one configurable touch input area 107 (a “virtual trackpad”), using the touchscreen of second display 102.

5 [0035] To identify a current posture of IHS 100 and a current physical relationship or spacial arrangement (e.g., distance, position, speed, etc.) between display(s) 101/102 and keyboard 103, IHS 100 may be configured to use one or more sensors disposed in first display 101, second display 102, keyboard 103, and/or hinge 104. Based upon readings from these various sensors, IHS 100 may then select, configure, modify, and/or provide (e.g., content, size, position, etc.) one  
10 or more UI features.

[0036] In various embodiments, displays 101 and 102 may be coupled to each other via hinge 104 to thereby assume a plurality of different postures, including, but not limited, to: laptop, tablet, book, or display.

[0037] When display 102 is disposed horizontally in laptop posture, keyboard 103 may be  
15 placed on top of display 102, thus resulting in a first set of UI features (e.g., ribbon area or touch bar 106, and/or touchpad 107). Otherwise, with IHS 100 still in the laptop posture, keyboard 103 may be placed next to display 102, resulting in a second set of UI features.

[0038] As used herein, the term “ribbon area” or “touch bar” 106 refers to a dynamic horizontal or vertical strip of selectable and/or scrollable items, which may be dynamically selected for  
20 display and/or IHS control depending upon a present context, use-case, or application. For example, when IHS 100 is executing a web browser, ribbon area or touch bar 106 may show navigation controls and favorite websites. Then, when IHS 100 operates a mail application, ribbon area or touch bar 106 may display mail actions, such as replying or flagging. In some cases, at least a portion of ribbon area or touch bar 106 may be provided in the form of a stationary control  
25 strip, providing access to system features such as brightness and volume. Additionally, or alternatively, ribbon area or touch bar 106 may enable multitouch, to support two or more simultaneous inputs.

[0039] In some cases, ribbon area 106 may change position, location, or size if keyboard 103 is moved alongside a lateral or short edge of second display 102 (e.g., from horizontally displayed  
30 alongside a long side of keyboard 103 to being vertically displayed alongside a short side of keyboard 103). Also, the entire display surface of display 102 may show rendered video frames

if keyboard 103 is moved alongside the bottom or long edge of display 102. Conversely, if keyboard 103 is removed or turned off, yet another set of UI features, such as an OSK, may be provided via display(s) 101/102. As such, in many embodiments, the distance and/or relative position between keyboard 103 and display(s) 101/102 may be used to control various aspects  
5 the UI.

[0040] During operation, the user may open, close, flip, swivel, or rotate either of displays 101 and/or 102, via hinge 104, to produce different postures. In each posture, a different arrangement between IHS 100 and keyboard 103 results in different UI features being presented or made available to the user. For example, when second display 102 is folded against display 101 so  
10 that the two displays have their backs against each other, IHS 100 may be said to have assumed a canvas posture (e.g., FIGs. 7A-F), a tablet posture (e.g., FIG. 7G-J), a book posture (e.g., FIG. 8D), a stand posture (e.g., FIGs. 9A and 9B), or a tent posture (e.g., FIGs. 9C and 9D), depending upon whether IHS 100 is stationary, moving, horizontal, resting at a different angle, and/or its orientation (landscape vs. portrait).

[0041] In many of these scenarios, placement of keyboard 103 upon or near display(s) 101/102, and subsequent movement or removal, may result in a different set of UI features than when IHS 100 is in laptop posture.  
15

[0042] In many implementations, different types of hinges 104 may be used to achieve and maintain different display postures, and to support different keyboard arrangements. Examples  
20 of suitable hinges 104 include, but are not limited to: a 360-hinge (FIGs. 12A-D), a jaws hinge (FIGs. 13A and 13B), a watchband hinge (FIG. 15), a gear hinge (FIGs. 16A-C), and a slide hinge (FIGs. 17A and 17B). One or more of these hinges 104 may include wells or compartments (FIG. 14) for docking, cradling, charging, or storing accessories. Moreover, one or more aspects of hinge 104 may be monitored via one or more sensors (e.g., to determine whether an accessory  
25 is charging) when controlling the different UI features.

[0043] In some cases, a folio case system (FIGs. 18A and 18B) may be used to facilitate keyboard arrangements. Additionally, or alternatively, an accessory backpack system (FIG. 19) may be used to hold keyboard 103 and/or an extra battery or accessory.

[0044] For purposes of this disclosure, an IHS may include any instrumentality or aggregate  
30 of instrumentalities operable to compute, calculate, determine, classify, process, transmit, receive, retrieve, originate, switch, store, display, communicate, manifest, detect, record,

reproduce, handle, or utilize any form of information, intelligence, or data for business, scientific, control, or other purposes. For example, an IHS may be a personal computer (e.g., desktop or laptop), tablet computer, mobile device (e.g., Personal Digital Assistant (PDA) or smart phone), server (e.g., blade server or rack server), a network storage device, or any other suitable device  
5 and may vary in size, shape, performance, functionality, and price. An IHS may include Random Access Memory (RAM), one or more processing resources such as a Central Processing Unit (CPU) or hardware or software control logic, Read-Only Memory (ROM), and/or other types of nonvolatile memory. Additional components of an IHS may include one or more disk drives, one or more network ports for communicating with external devices as well as various I/O devices,  
10 such as a keyboard, a mouse, touchscreen, and/or a video display. An IHS may also include one or more buses operable to transmit communications between the various hardware components.

[0045] FIG. 2 is a block diagram of components 200 of multi-form factor IHS 100. As depicted, components 200 include processor 201. In various embodiments, IHS 100 may be a single-processor system, or a multi-processor system including two or more processors. Processor 201  
15 may include any processor capable of executing program instructions, such as a PENTIUM series processor, or any general-purpose or embedded processors implementing any of a variety of Instruction Set Architectures (ISAs), such as an x86 ISA or a Reduced Instruction Set Computer (RISC) ISA (e.g., POWERPC, ARM, SPARC, MIPS, etc.).

[0046] IHS 100 includes chipset 202 coupled to processor 201. In certain embodiments, chipset 202 may utilize a QuickPath Interconnect (QPI) bus to communicate with processor 201.  
20 In various embodiments, chipset 202 may provide processor 201 with access to a number of resources. Moreover, chipset 202 may be coupled to communication interface(s) 205 to enable communications via various wired and/or wireless networks, such as Ethernet, WiFi, BLUETOOTH, cellular or mobile networks (e.g., CDMA, TDMA, LTE, etc.), satellite networks, or  
25 the like. For example, communication interface(s) 205 may be coupled to chipset 202 via a PCIe bus.

[0047] Chipset 202 may be coupled to display controller(s) 204, which may include one or more or graphics processor(s) (GPUs) on a graphics bus, such as an Accelerated Graphics Port (AGP) or Peripheral Component Interconnect Express (PCIe) bus. As shown, display controller(s)  
30 204 provide video or display signals to first display device 101 and second display device 202. In other implementations, any number of display controller(s) 204 and/or display devices 101/102 may be used.

[0048] Each of display devices 101 and 102 may include a flexible display that is deformable (e.g., bent, folded, rolled, or stretched) by an external force applied thereto. For example, display devices 101 and 102 may include LCD, OLED, or AMOLED, plasma, electrophoretic, or electrowetting panel(s) or film(s). Each display device 101 and 102 may include a plurality of  
5 pixels arranged in a matrix, configured to display visual information, such as text, two-dimensional images, video, three-dimensional images, etc.

[0049] Display device(s) 101/102 may be configured to sense haptic and/or physical touch events, and to generate touch information. To this end, display device(s) 101/102 may include a touchscreen matrix (e.g., a layered capacitive panel or the like) and/or touch controller configured  
10 to receive and interpret multi-touch gestures from a user touching the screen with a stylus or one or more fingers. In some cases, display and touch control aspects of display device(s) 101/102 may be collectively operated and controlled by display controller(s) 204.

[0050] In some cases, display device(s) 101/102 may also comprise a deformation or bending sensor configured to generate deformation or bending information including, but not limited to:  
15 the bending position of a display (e.g., in the form of a "bending line" connecting two or more positions at which bending is detected on the display), bending direction, bending angle, bending speed, etc. In these implementations, display device(s) 101/102 may be provided as a single continuous display, rather than two discrete displays.

[0051] Chipset 202 may also provide processor 201 and/or display controller(s) 204 with  
20 access to memory 203. In various embodiments, system memory 203 may be implemented using any suitable memory technology, such as static RAM (SRAM), dynamic RAM (DRAM) or magnetic disks, or any nonvolatile/Flash-type memory, such as a solid-state drive (SSD) or the like. Memory 203 may store program instructions that, upon execution by processor 201 and/or controller(s) 204, present a UI interface to a user of IHS 100.

[0052] Chipset 202 may further provide access to one or more hard disk and/or solid-state  
25 drives 207. In certain embodiments, chipset 202 may also provide access to one or more optical drives or other removable-media drives. In certain embodiments, chipset 202 may also provide access to one or more Universal Serial Bus (USB) ports 208.

[0053] Upon booting of IHS 100, processor(s) 201 may utilize Basic Input/Output System  
30 (BIOS) 209 instructions to initialize and test hardware components coupled to IHS 100 and to load an Operating System (OS) for use by IHS 100. BIOS 209 provides an abstraction layer that

allows the OS to interface with certain hardware components that are utilized by IHS 100. Via the hardware abstraction layer provided by BIOS 209, software stored in memory 203 and executed by the processor(s) 201 of IHS 100 is able to interface with certain I/O devices that are coupled to the IHS 100. The Unified Extensible Firmware Interface (UEFI) was designed as a successor to BIOS. As a result, many modern IHSs utilize UEFI in addition to or instead of a BIOS. As used herein, BIOS is intended to also encompass UEFI.

[0054] Chipset 202 may also provide access to one or more user input devices 206, for example, using a super I/O controller or the like. For instance, chipset 202 may provide access to a keyboard (e.g., keyboard 103), mouse, trackpad, stylus, totem, or any other peripheral input device, including touchscreen displays 101 and 102. These input devices may interface with chipset 202 through wired connections (e.g., in the case of touch inputs received via display controller(s) 204) or wireless connections (e.g., via communication interfaces(s) 205). In some cases, chipset 202 may be used to interface with user input devices such as keypads, biometric scanning devices, and voice or optical recognition devices.

[0055] In certain embodiments, chipset 202 may also provide an interface for communications with one or more sensors 210. Sensors 210 may be disposed within displays 101/102 and/or hinge 104, and may include, but are not limited to: electric, magnetic, radio, optical, infrared, thermal, force, pressure, acoustic, ultrasonic, proximity, position, deformation, bending, direction, movement, velocity, rotation, and/or acceleration sensor(s).

[0056] FIG. 3 is a block diagram of components 300 of keyboard 103. As depicted, components 300 include keyboard controller or processor 301, coupled to keyboard sensor(s) 303 and wireless communication module 302. In various embodiments, keyboard controller 301 may be configured to detect keystrokes made by user upon a keyboard matrix, and it may transmit those keystrokes to IHS 100 via wireless module 302 using a suitable protocol (e.g., BLUETOOTH). Keyboard sensors 303, which may also include any of the aforementioned types of sensor(s), may be disposed under keys and/or around the keyboard's enclosure, to provide information regarding the location, arrangement, or status of keyboard 103 to IHS 100 via wireless module 302. In other implementations, however, one or more keyboard sensors 303 (e.g., one or more Hall effect sensors, a magnetometer, etc.) may be disposed within first and/or second displays 101/102.

[0057] In some cases, a magnetic attachment and alignment system(s) may enable keyboard 103 to be attached to second display 102 (on the display surface, or on the back of display 102), and/or to be aligned on/off the surface of display 102, at predetermined locations. Moreover, display and/or hinge sensors 210 may be configured to determine which of a plurality of magnetic devices are presently engaged, so that the current position of keyboard 103 may be ascertained with respect to IHS 100. For example, keyboard 103 may have magnetic devices disposed along its short sides at selected locations. Moreover, second display 102 may include magnetic devices at locations that correspond to the keyboard's magnetic devices, and which snap keyboard 103 into any number of predetermined locations over the display surface of second display 102 alongside its short sides.

[0058] In various embodiments, systems and methods for on-screen keyboard detection may include a "fixed-position via Hall sensors" solution implemented as hardware/firmware that reads the multiple Hall sensors' information, calculates where a keyboard is detected, and sends the keyboard location (fixed positions) information to an OS. Additionally, or alternatively, these systems and methods may include a "variable-position via Hall sensors" solution implemented as hardware/firmware that reads a single Hall sensor's information based on the variable Gauss value of magnet(s) on keyboard 103.

[0059] Additionally, or alternatively, these systems and methods may include a "variable position via magnetometer" solution implemented as hardware/firmware that reads a single magnetometer's information based the relative location a single magnet on keyboard 103. Additionally, or alternatively, these systems and methods may include a "variable position via 3D Hall sensor" solution implemented as hardware/firmware that reads a 3D Hall sensor's information based the relative location a programmed magnet (different polarities) or array of magnets in different orientations on keyboard 103.

[0060] In some cases, by using magnetic keyboard detection, instead of relying upon touch sensors or the digitizer built into display 102, systems and methods described herein may be made less complex, using less power and fewer compute resources. Moreover, by employing a separate magnetic sensing system, IHS 100 may turn off touch in selected areas of display 102 such as, for example, in the areas of display 102 covered by keyboard 103.

[0061] In various embodiments, IHS 100 and/or keyboard 103 may not include all of components 200 and/or 300 shown in FIGs. 2 and 3, respectively. Additionally, or alternatively,

IHS 100 and/or keyboard 103 may include components in addition to those shown in FIGs. 2 and 3, respectively. Additionally, or alternatively, components 200 and/or 300, represented as discrete in FIGs. 2 and 3, may be integrated with other components. For example, all or a portion of the functionality provided by components 200 and/or 300 may be provided as a System-On-Chip (SOC), or the like.

[0062] FIG. 4 is a block diagram of multi-form factor configuration engine 401. Particularly, multi-form factor configuration engine 401 may include electronic circuits and/or program instructions that, upon execution, cause IHS 100 to perform a number of operation(s) and/or method(s) described herein.

10 [0063] In various implementations, program instructions for executing multi-form factor configuration engine 401 may be stored in memory 203. For example, engine 401 may include one or more standalone software applications, drivers, libraries, or toolkits, accessible via an Application Programming Interface (API) or the like. Additionally, or alternatively, multi-form factor configuration engine 401 may be included the IHS's OS.

15 [0064] In other embodiments, however, multi-form factor configuration engine 401 may be implemented in firmware and/or executed by a co-processor or dedicated controller, such as a Baseband Management Controller (BMC), or the like.

[0065] As illustrated, multi-form factor configuration engine 401 receives Graphical User Interface (GUI) input or feature 402, and produces GUI output or feature 403, in response to receiving and processing one or more or: display sensor data 406, hinge sensor data 407, and/or keyboard sensor data 408. Additionally, or alternatively, multi-form factor configuration engine 401 may produce touch control feature 404 and/or other commands 405.

[0066] In various embodiments, GUI input 402 may include one or more images to be rendered on display(s) 101/102, and/or one or more entire or partial video frames. Conversely, GUI output 403 may include one or more modified images (e.g., different size, color, position on the display, etc.) to be rendered on display(s) 101/102, and/or one or more modified entire or partial video frames.

[0067] For instance, in response to detecting, via display and/or hinge sensors 406/407, that IHS 100 has assumed a laptop posture from a closed or "off" posture, GUI OUT 403 may allow a full-screen desktop image, received as GUI IN 402, to be displayed first display 101 while second

display 102 remains turned off or darkened. Upon receiving keyboard sensor data 408 indicating that keyboard 103 has been positioned over second display 102, GUI OUT 403 may produce a ribbon-type display or area 106 around the edge(s) of keyboard 103, for example, with interactive and/or touch selectable virtual keys, icons, menu options, pallets, etc. If keyboard sensor data  
5 408 then indicates that keyboard 103 has been turned off, for example, GUI OUT 403 may produce an OSK on second display 102.

[0068] Additionally, or alternatively, touch control feature 404 may be produced to visually delineate touch input area 107 of second display 102, to enable its operation as a user input device, and to thereby provide an UI interface commensurate with a laptop posture. Touch control  
10 feature 404 may turn palm or touch rejection on or off in selected parts of display(s) 101/102. Also, GUI OUT 403 may include a visual outline displayed by second display 102 around touch input area 107, such that palm or touch rejection is applied outside of the outlined area, but the interior of area 107 operates as a virtual trackpad on second display 102.

[0069] Multi-form factor configuration engine 401 may also produce other commands 405 in  
15 response to changes in display posture and/or keyboard state or arrangement, such as commands to turn displays 101/102 on or off, enter a selected power mode, charge or monitor a status of an accessory device (e.g., docked in hinge 104), etc.

[0070] FIG. 5 is a flowchart of method 500 for configuring multi-form factor IHSs. In various embodiments, method 500 may be performed by multi-form factor configuration engine 401 under  
20 execution of processor 201. At block 501, method 500 includes identifying a display posture—that is, a relative physical arrangement between first display 101 and second display 102. For example, block 501 may use sensor data received from displays 101/102 and/or hinge 104 to distinguish among the various postures shown below.

[0071] At block 502, method 500 selects a UI feature corresponding to the identified posture.  
25 Examples of UI features include, but are not limited to: turning a display on or off; displaying a full or partial screen GUI; displaying a ribbon area; providing a virtual trackpad area; altering touch control or palm rejection settings; adjusting the brightness and contrast of a display; selecting a mode, volume, and/or or directionality of audio reproduction; etc.

[0072] At block 503, method 500 may detect the status of keyboard 103. For example, block  
30 503 may determine that keyboard 103 is on or off, resting between two closed displays, horizontally sitting atop display(s) 101/102, or next to display(s) 101/102. Additionally, or

alternatively, block 503 may determine the location or position of keyboard 103 relative to display 102, for example, using Cartesian coordinates. Additionally, or alternatively, block 503 may determine an angle between keyboard 103 and displays 101/102 (e.g., a straight angle if display 102 is horizontal, or a right angle if display 102 is vertical).

5 [0073] Then, at block 504, method 500 may modify the UI feature in response to the status of keyboard 103. For instance, block 504 may cause a display to turn on or off, it may change the size or position of a full or partial screen GUI or a ribbon area, it may change the size or location of a trackpad area with changes to control or palm rejection settings, etc. Additionally, or alternatively, block 504 may produce a new interface feature or remove an existing feature,  
10 associated with a display posture, in response to any aspect of the keyboard status meeting a selected threshold of falling within a defined range of values.

[0074] FIGs. 6A-C, 7A-J, 8A-D, and 9A-F illustrate examples of various display postures which may be detected by operation of block 501 of method 500 during execution of multi-form factor configuration engine 401 by IHS 100. In some implementations, different ranges of hinge  
15 angles may be mapped to different IHS postures as follows: closed posture (0 to 5 degrees), laptop or book posture (5 to 175 degrees), canvas posture (175 to 185 degrees), tent or stand posture (185 to 355 degrees), and/or tablet posture (355 to 360 degrees).

[0075] Particularly, FIGs. 6A-C show a laptop posture, where a first display surface of first display 101 is facing the user at an obtuse angle with respect to a second display surface of  
20 second display 102, and such that second display 102 is disposed in a horizontal position, with the second display surface facing up. In FIG. 6A, state 601 shows a user operating IHS 100 with a stylus or touch on second display 102. In FIG. 6B, state 602 shows IHS 100 with keyboard 103 positioned off the bottom edge or long side of second display 102, and in FIG. 6C, state 603 shows the user operating keyboard 103 atop second display 102.

25 [0076] FIGs. 7A-J show a tablet posture, where first display 101 is at a straight angle with respect to second display 102, such that first and second displays 101 and 102 are disposed in a horizontal position, with the first and second display surfaces facing up. Specifically, FIG. 7A shows state 701 where IHS 100 is in a side-by-side, portrait orientation without keyboard 103, FIG. 7B shows state 702 where keyboard 103 is being used off the bottom edges or short sides  
30 of display(s) 101/102, and FIG. 7C shows state 703 where keyboard 103 is located over both displays 101 and 102. In FIG. 7D, state 704 shows IHS 100 in a side-by-side, landscape

configuration without keyboard 103, in FIG. 7E state 705 shows keyboard 103 being used off the bottom edge or long side of second display 102, and in FIG. 7F state 706 shows keyboard 103 on top of second display 102.

[0077] In FIG. 7G, state 707 shows first display 101 rotated around second display 102 via hinge 104 such that the display surface of second display 102 is horizontally facing down, and first display 101 rests back-to-back against second display 102, without keyboard 103; and in FIG. 7H, state 708 shows the same configuration, but with keyboard 103 placed off the bottom or long edge of display 102. In FIGs. 7I and 7J, states 709 and 710 correspond to states 707 and 708, respectively, but with IHS 100 in a portrait orientation.

[0078] FIG. 8A-D show a book posture, similar to the tablet posture of FIGs. 7A-J, but such that neither one of displays 101 or 102 is horizontally held by the user and/or such that the angle between the display surfaces of the first and second displays 101 and 102 is other than a straight angle. In FIG. 8A, state 801 shows dual-screen use in portrait orientation, in FIG. 8B state 802 shows dual-screen use in landscape orientation, in FIG. 8C state 803 shows single-screen use in landscape orientation, and in FIG. 8D state 804 shows single-screen use in portrait orientation.

[0079] FIGs. 9A-F show a display posture, where first display 100 is at an acute angle with respect to second display 102, and/or where both displays are vertically arranged in a portrait orientation. Particularly, in FIG. 9A state 901 shows a first display surface of first display 102 facing the user and the second display surface of second display 102 horizontally facing down in a stand configuration (“stand”), whereas in FIG. 9B state 902 shows the same stand configuration but with keyboard 103 used off the bottom edge or long side of display 101. In FIG. 9C, state 903 shows a display posture where display 102 props up display 101 in a tent configuration (“tent”), and in FIG. 9D, state 904 shows the same tent configuration but with keyboard 103 used off the bottom edge or long side of display 101. In FIG. 9E, state 905 shows both displays 101 and 102 resting vertically or at display angle (“dual-display mode”), and in FIG. 9F state 906 shows the same configuration but with keyboard 103 used off the bottom edge or long side of display 101.

[0080] It should be noted that the aforementioned postures, and their various respective keyboard states, are described for sake of illustration. In different embodiments, however, other postures and keyboard states may be used, for example, depending upon the type of hinge coupling the displays, the number of displays used, or other accessories. For instance, when IHS 100 is chargeable via a charging or docking station, the connector in the docking station may be

configured to hold IHS 100 at angle selected to facilitate one of the foregoing postures (e.g., keyboard states 905 and 906).

[0081] FIGs. 10A-C illustrate a first example use-case of method 500 in the context of a laptop posture. In state 1000A of FIG. 10A, first display 101 shows primary display area 1001, keyboard 103 sits atop second display 102, and second display 102 provides UI features such as first ribbon area 1002 (positioned between the top long edge of keyboard 103 and hinge 104) and touch area 1003 (positioned below keyboard 103). As keyboard 103 moves up or down on the surface of display 102, ribbon area 1002 and/or touch area 1003 may dynamically move up or down, or become bigger or smaller, on second display 102. In some cases, when keyboard 103 is removed, a virtual OSK may be rendered (e.g., at that same location) on the display surface of display 102.

[0082] In state 1000B of FIG. 10B, in response to execution of method 500 by multi-form factor configuration engine 401, first display 101 continues to show main display area 1001, but keyboard 103 has been moved off of display 102. In response, second display 102 now shows secondary display area 1004 and also second ribbon area 1005. In some cases, second ribbon area 1005 may include the same UI features (e.g., icons, etc.) as also shown in area 1002, but here repositioned to a different location of display 102 nearest the long edge of keyboard 103. Alternatively, the content of second ribbon area 1005 may be different from the content of first ribbon area 1002.

[0083] In state 1000C of FIG. 10C, during execution of method 500 by multi-form factor configuration engine 401, IHS 100 detects that physical keyboard 103 has been removed (e.g., out of wireless range) or turned off (e.g., low battery), and in response display 102 produces a different secondary display area 1006 (e.g., smaller than 1004), as well as OSK 1007.

[0084] FIGs. 11A-C illustrate a second example use-case of method 500 in the context of a tablet posture. In state 1100A of FIG. 11A, second display 102 has its display surface facing up, and is disposed back-to-back with respect to second display 102, as in states 709/710, but with keyboard 103 sitting atop second display 102. In this state, display 102 provides UI features such as primary display area 1101 and first ribbon area 1102, positioned as shown. As keyboard 103 is repositioned up or down on the surface of display 102, display area 1101, first ribbon area 1102, and/or touch area 1103 may also be moved up or down, or made bigger or smaller, by multi-form factor configuration engine 401.

[0085] In state 1100B of FIG. 11B, keyboard 103 is detected off of the surface of display 102. In response, first display 101 shows modified main display area 1103 and modified ribbon area 1104. In some cases, modified ribbon area 1104 may include the same UI features as area 1102, but here repositioned to a different location of display 102 nearest the long edge of keyboard 103.  
5 Alternatively, the content of second ribbon area 1104 may be different from the content of first ribbon area 1102. In some cases, the content and size of modified ribbon area 1104 may be selected in response to a distance between keyboard 103 and display 102.

[0086] In state 1100C of FIG. 11C, during continued execution of method 500, multi-form factor configuration engine 401 detects that physical keyboard 103 has been removed or turned  
10 off, and in response display 102 produces yet another display area 1105 (e.g., larger than 1003 or 1002), this time without an OSK.

[0087] In various embodiments, the different UI behaviors discussed in the aforementioned use-cases may be set, at least in part, by policy and/or profile, and stored in a preferences database for each user. In this manner, UI features and modifications of blocks 502 and 504,  
15 such as whether touch input area 1003 is produced in state 1000A (and/or its size and position on displays 101/102), or such as whether ribbon area 1102 is produced in state 1100A (and/or its size and position on displays 101/102), may be configurable by a user.

[0088] FIGs. 12A-D illustrate a 360-hinge implementation, usable as hinge 104 in IHS 100, in four different configurations 1200A-D, respectively. Particularly, 360-hinge 104 may include a  
20 plastic, acrylic, polyamide, polycarbonate, elastic, and/or rubber coupling, with one or more internal support, spring, and/or friction mechanisms that enable a user to rotate displays 101 and 102 with respect to one another, around the axis of 360-hinge 104.

[0089] Hinge configuration 1200A of FIG. 12A may be referred to as a closed posture, where at least a portion of a first display surface of the first display 101 is disposed against at least a  
25 portion of a second display surface of the second display 102, such that the space between displays 101/102 accommodates keyboard 103. When display 101 is against display 102, stylus or accessory 108 may be slotted into keyboard 103. In some cases, stylus 108 may have a diameter larger than the height of keyboard 103, so that 360-hinge 104 wraps around a portion of the circumference of stylus 108 and therefore holds keyboard 103 in place between displays  
30 101/102.

[0090] Hinge configuration 1200B of FIG. 12B shows a laptop posture between displays 101/102. In this case, 360-hinge 104 holds first display 101 up, at an obtuse angle with respect to first display 101. Meanwhile, hinge configuration 1200C of FIG. 12C shows a tablet, book, or display posture (depending upon the resting angle and/or movement of IHS 100), with 360-hinge 5 104 holding first and second displays 101/102 at a straight angle (180°) with respect to each other. And hinge configuration 1200D of FIG. 12D shows a tablet or book configuration, with 360-hinge 104 holding first and second displays 101 and 102 at a 360° angle, with their display surfaces in facing opposite directions.

[0091] FIGs. 13A and 13B illustrate a jaws hinge implementation, usable as hinge 104 in IHS 10 100, in two different configurations 1300A and 1300B. Specifically, jaws hinge 104 has two rotation axes, parallel to each other, one axis for each respective one of displays 101/102. A solid bar element 104 between the two rotation axes may be configured to accommodate docking compartment 1301 for stylus 108, audio speaker(s) 1302 (e.g., monaural, stereo, a directional array), and one or more ports 1303 (e.g., an audio in/out jack).

[0092] Hinge configuration 1300A of FIG. 13A shows the laptop posture. In this case, jaws hinge 104 holds first display 101 up, at an obtuse angle with respect to second display 102. In contrast, hinge configuration 1300B of FIG. 13B shows a tablet or book posture, with jaws hinge 104 holding first and second displays 101 and 102 at a 360° angle with respect to each other, with keyboard 103 stored in between displays 101 and 102, in a back-to-back configuration, such 20 that stylus 108 remains accessible to the user.

[0093] FIG. 14 illustrates accessory charging system 1400, with accessory wells 1301 and 1401 shown on hinge 104 that couples first display 101 to second display 102. In various embodiments, accessory wells 1301 and 1401 may be formed of molded or extruded plastic. In this example, accessory well 1301 is shaped to hold pen or stylus 108, and accessory well 1401 25 is shaped to hold earbud 109. In some implementations, wells 1301 and/or 1401 may include electrical terminals for charging a battery within the accessory, and/or to check a status of the accessory (e.g., presence, charge level, model or name, etc.).

[0094] FIG. 15 illustrates a watchband hinge implementation, usable as hinge 104 in IHS 100, in configuration 1500. Specifically, watchband hinge 104 comprises a plurality of metal cylinders 30 or rods, with axes parallel to each other, held together by bracket 1503 and/or fabric 1501. In

operation, bracket 1503 may include notches and/or detents configured to hold cylinders 1502 at predetermined positions corresponding to any available IHS posture.

[0095] FIGs. 16A-C illustrate a gear hinge implementation, usable as hinge 104 in IHS 100, in configurations 1600A-C. Specifically, configuration 1600A of FIG. 16A shows gear hinge 104 with bar 1603 having teeth or gears 1604 fabricated thereon, as IHS 100 begins to assume a laptop posture. Display 101 has teeth or gears 1601 alongside its bottom edge, whereas display 102 has teeth or gears 1602 alongside its top edge. Bracket(s) 1605 hold gears 1601 and/or 1602 against gear 1604, therefore provides two parallel rotation axes between displays 101 and 102.

[0096] Hinge configuration 1600B of FIG. 16B shows a closed posture. In this case, gear hinge 104 holds display 101 facing down, and display 102 is rotated 360° degrees with respect to display 101, so that its display surface faces up against display 101. In this configuration, keyboard 103 may sit under display 102, for example, to cause display 102 to rest at an angle when IHS 100 is placed in laptop posture. In some cases, keyboard 103 may be coupled to the back of display 102 using an accessory backpack or the like, as shown in FIG. 19.

[0097] Hinge configuration 1600C of FIG. 16C shows a tablet or book posture. In this case, gear hinge 104 holds display 102 facing up, and display 101 is rotated 360° degrees with respect to display 102, so that its display surface faces down against the horizontal plane. In this configuration, keyboard 103 rests between the back of display 101 and the back of display 102. In various embodiments, bar 1603 may be split into a plurality of segments or links, as shown in configurations 1600B and 1600C, to provide additional axes of rotation between displays 101 and 102, and to accommodate both keyboard options with different IHS thicknesses.

[0098] FIGs. 17A and 17B illustrate a slide hinge implementation, usable as hinge 104 in IHS 100, in various configurations. Specifically, in FIG. 17A, link 1701, held by first display bracket 1702 coupled to display 101, slides up and down slot 1704 of bracket 1703 coupled to display 102. In some cases, a locking mechanism may be employed to stably hold displays 101 and 102 in different postures, as link 1701 slides up and down and/or as display 101 rotates around display 102, such as the closed posture of configuration 1700A, the laptop posture of configuration 1700B in FIG. 17B, the tablet posture of configuration 1700C (back to FIG. 17A), or the book posture of configuration 1700D (also in FIG. 17A).

[0099] FIGs. 18A and 18B illustrate a folio case system in configurations 1800A and 1800B, according to some embodiments. Specifically, folio case 1801 may include a set of hard foldable sections or flaps wrapped in fabric and/or plastic, with snapping magnetic attachment points, for example, around the edge on the back of displays 101 and 102, and/or keyboard 103. In some cases, keyboard 103 may be removable from case 1801. Additionally, or alternatively, the presence and state of case 1801 may be detectable via sensors 303.

[00100] In configuration 1800A in FIG. 18A, displays 101 and 102 are in a laptop posture, and folio case 1801 holds keyboard 103 in a fixed position, off the bottom edge or long side of display 102, such that both displays 101 and 102 remain usable. Meanwhile, configuration 1800B of FIG. 18B shows a display posture (e.g., as in state 901), such that the display surface of display 102 is facing down against folio case 1802, and folio case 1802 holds keyboard 103 in at fixed location, off the bottom edge of display 101, and such that only display 101 is usable.

[00101] FIG. 19 illustrates accessory backpack system 1900. In some embodiments, the enclosure of display 102 may include notches 1903 configured to receive lip 1902 of tray 1901, which stays snapped in place until pulled by the user. Additionally, or alternatively, a spring-loaded ejection button may be used. In various configurations, tray 1901 may hold keyboard 103 or battery 110. Moreover, in some cases, the enclosure of display 102 may include electrical terminals usable to charge and/or obtain sensor information from accessories.

[00102] Context-Aware User Interface (UI)

[00103] In various embodiments, systems and methods described herein may provide a context-aware UI for IHS 100. For instance, GUI objects such as ribbon area 106 and touch input area 107 may be selected, configured, modified, provided, or excluded based upon the context in which IHS 100 is operating.

[00104] For example, during operation of IHS 100, an application or window may occupy a part of a display (“single display window mode”), it may occupy an entire display (“max mode”), it may span across parts of the two displays (“dual display window mode”), or it may occupy both entire displays (“supermax mode”). Moreover, when in a laptop or tablet posture mode, for instance, a user may place a supported physical keyboard 103, totem (e.g., a DELL TOTEM), or another accessory on the surface of second display 102. Additionally, or alternatively, the user may bring up an OSK on second display 102.

[00105] Still during operation of IHS 100, the user may move keyboard 103 to different positions on the display surface of second display 102. Additionally, or alternatively, the user may close, open, minimize, or maximize an application or window. Additionally, or alternatively, the user may transition IHS 100 between different display postures. Additionally, or alternatively, the user may dock IHS 100 on a docking system or the like, thereby modifying the IHS's docking state (e.g., dual monitor mode, book mode, or laptop mode).

[00106] In response to these, or other events, IHS 100 may select, render, modify, expand, reduce, and/or exclude various UI components or GUI objects such as: applications, OSKs, touch bars, touchpads, workspaces, taskbars, start menus, etc., in a context-aware manner. These context-aware operations may be performed, for example, based on docking state, active application, touchpad area, physical keyboard placement and area, totem placement (if any), etc.

[00107] For instance, in response to changes in docking state, IHS 100 may bring up, hide, or resize an "f-row interface" comprising one or more of: a "system bar," a "touch bar," and an "activity bar;" as well as the contents (e.g., icons, keys, text, colors, images, suggestions, shortcuts, input areas, etc.) of each such bar. Additionally, or alternatively, IHS 100 may bring up, configure, hide, or resize OSKs, touchpad areas, scratch pad areas, or totem menus. Additionally, or alternatively, IHS 100 may reduce or increase desktop or workspace areas that span two displays, and it may move OS components, such as a taskbar and start menu, across displays 101 and 102.

[00108] In an embodiment, a user may manually configure one or more GUI components, elements, or objects (e.g., f-row interface, touchpad, OSK, icons, images, windows, etc.) with a desired size and selected contents, and the user may also choose taskbar/start menu icon locations with posture-dependent, event-specific triggers and behaviors. In another embodiment, a software service may a docking state changes, posture changes, user configuration changes (e.g., user brings up OSK mode), placement of a keyboard, totem placed on display, active application, etc., and it may take automatic responsive actions. In some cases, second display 102 may display touch bar content that is selected based upon other content displayed on first display 101 (e.g., an active application).

[00109] FIGs. 20A and 20B are a flowchart of method 2000 for providing a context-aware UI. In some embodiments, method 2000 may be performed by multi-form factor configuration engine 401 under execution of processor 201. Particularly, method 2000 starts at block 2001.

[00110] At block 2002, method 2000 loads user configuration and/or preferences from saved configuration files 2003. For example, configuration files 2003 may be saved in a database and stored in memory storage devices 203/207. In various embodiments, configuration files 2003 may contain user and/or application –specific settings that control the behavior of GUI components such as, for example, touch bar 106 and touchpad 107, in response to selected events. For example, configuration files 2003 may prioritize the rendering of one or more sub-components of touch bar 106 (e.g., a system bar, a touch bar, or an activity bar) and/or one or more sub-components of touch input area 107 (e.g., a trackpad and one or more scratchpad areas), according to the user's personal preferences, depending upon the position of keyboard 103 on second display 102 and/or the docking state of IHS 100.

[00111] At block 2004, method 2000 waits for an event to be received from any of blocks 2005-2009. Specifically, block 2005 indicates when an application is open, closed, or resized, and block 2006 indicates when an OSK mode is selected or brought up by an application (also examples of GUI IN 402 inputs in FIG. 4). Block 2007 detects and identifies changes in display posture, for example, using a gyroscope, accelerometer, IMU, hinge sensor, etc.; whereas blocks 2008 and 2009 detect the presence, position, and status of keyboard 103, totem, or other accessory, including moving and removal events, for example, using display, hinge, and keyboard sensors (also examples of sensor data 406-408 of FIG. 4).

[00112] At block 2010, method 2000 determines a current posture of IHS 100 using data from blocks 2005-2009 by comparing the various current states of different IHS components to the corresponding states expected for each posture. Block 2011 determines whether: (i) the posture has changed; (ii) OSK mode has been brought up, closed, or changed, or (iii) keyboard 103 has been placed, moved, or removed, or (iv) the IHS has been docked, and in which state.

[00113] If so, block 2012 may calculate and apply a new workspace or desktop area by resizing and/or closing applications and windows using OS-specific (e.g., WINDOWS) API-based graphics (GFX) commands. Block 2013 may calculate and apply new ribbon area bars and components, with selected sizes and at predetermined locations, using the API to generate f-row UI commands. Similarly, block 2014 may calculate and apply new touch input area components such as a touchpad and one or more strachpad(s), with selected sizes and at predetermined locations, using the API to generate touchpad UI commands. In some cases, method 2000 may also calculate and apply OS components at block 2015, such as a taskbar or start menu, with selected sizes

and at predetermined locations, using the API to generate OS configuration commands. After any of blocks 2012-2015, control returns to block 2004.

5 [00114] At block 2016, method 2000 determines whether an application has been opened, moved, minimized, maximized, or super-maximized. If so, block 2017 may calculate and resize applications and windows using the API, and control returns to block 2004. At block 2018, method 2000 determines whether a totem has been placed, removed, or moved, or whether a totem menu selection event has occurred. If so, block 2019 may send a totem event notification to the OS and/or it may enable totem controls using the API, and then control returns to block 2004. Otherwise, method 2000 ends at block 2020.

10 [00115] Docking System

[00116] In various embodiments, multi-form factor IHS 100 may be used with a docking system as described herein. Such a docking system may operate as a stand, to mechanically support displays 101 and 102 in different postures and orientations, and it may also enable IHS 100 to be connected and disconnected to and from any of a plurality of power sources (e.g., AC power) and/or peripheral components (e.g., an external graphics processor) coupled or built into to the docking system.

20 [00117] FIGs. 21A-C illustrate a docking system in different positions. In FIG. 21A, docking system 2100A is shown with base 2101 and plateau 2104 coupled to each other via arm(s) 2103 (in this example, two arms are used). Both base 2101 and plateau 2104 may be generally rectangular in shape, and may have a width configured to match the width of a single one of displays 101/102. Base 2101 sits horizontally on a table or desk surface, and when IHS 100 is docked on docking system 2100A, the back surface of display 101 and/or the back surface of display 102 is/are coupled to and rest(s) against the top surface of plateau 2104.

25 [00118] Arm(s) 2103 couple distal edge 2108D of base 2101 (relative to a user standing in front of docking system 2100) to proximal edge 2108P of plateau 2104. As such, arm(s) 2103 swivel, hinge, or rotate with respect to base 2101 around a first axis to lift plateau 2104 vertically and away from the horizontal surface. Arm(s) 2103 also swivel, hinge, or rotate around a second axis to tilt plateau 2104, hence angling displays 101/102 towards or away from a user. When retracted into position 2100B, arm(s) 2103 fall into recessed track(s) 2102 of base 2101, such  
30 that the bottom surface of plateau 2104 rests against the top surface of base 2101.

[00119] The top or outer surface of plateau 2104 includes positioning nib 2105 with horizontal row of connector terminals 2106H and/or vertical column of connector terminals 2106V. In some implementations, positioning nib 2105 may be generally square in shape, which allows IHS 100 to be supported by docking system 2100 in at least two orientations, 90° rotated with respect to each other.

[00120] Horizontal terminals 2106H may be disposed alongside a first side of square nib 2105, and vertical terminals 2106V may be perpendicular thereto. For example, horizontal row of terminals 2106H may provide a first bus connector (e.g., USB) and vertical column of terminals 2106V may provide a different bus connector or a redundant bus connector, in a different orientation. In various situations, terminals 2106H-V may be used to implement cooling, data, and/or charging of IHS 100.

[00121] Plateau 2104 may also include a generally rectangular magnetic device 2107 disposed in a direction perpendicular to proximal edge 2108P of plateau 2104, and configured to hold displays 101 and/or 102 in place when IHS 100 is docked. In some cases, magnetic device 2107 may include a programmed magnet or magnet array that features different North, South, East, and West poles or polarities along its length, whereas displays 101 and/or 102 of IHS 100 may include correspondingly disposed magnets with opposite poles or polarities.

[00122] In some cases, as shown dock 2100C of FIG. 21C, plateau 2104 and/or base 2101 may further include one or more peripheral devices built therein. For example, device 2108 may include a cooling fan and/or graphics processor 2108 coupled to terminals 2106H-V. Upon docking of IHS 100 onto plateau 2104, IHS 100 may be configured to identify the current docking state and to access or communicate with device 2108 via terminals 2106H and/or 2106V.

[00123] FIGs. 22A and 22B illustrate examples of docking and undocking methods, and FIGs. 23A-C show the resulting docking states. Particularly, configuration 2200A of FIG. 22A shows IHS 100 docked onto plateau 2104 in a dual monitor docking state, such as when IHS 100 is in posture 701 in FIG. 7A, or posture 905 of FIG. 9E.

[00124] In the docking process of FIG. 22A, a user may first place IHS 100 in dual monitor posture, with displays 101/102 open 180° and in a portrait orientation. The user may then align the back of second display 102 against positioning nib 2105. For example, the back of second display 102 may include a protrusion or detent 2202 configured to match the shape of positioning nib 2105, and configured to align IHS 100, in response to IHS 100 being positioned against the

top surface of plateau 2104. In some cases, protrusion or detent 2202 may be male and positioning nib 2105 may be female, or vice-versa.

[00125] First display 101 may include magnetic device 2201 (with opposite polarity as magnetic device 2107 of plateau 2104) configured such that, when detent 2202 is aligned with nib 2105, magnetic device 2107 snaps or holds IHS 100 in place against plateau 2104 (in this case, magnetic device 2203 within second display 102 is not engaged).

[00126] As a result of the process of FIG. 22A, FIG. 23A shows IHS 100 and docking system 2100 in dual-display docking mode 2300A and FIG. 23B shows book docking mode 2300B. Arm 2103 may be actuated to hold plateau 2104 in a dual-display docking state 2300A by extending arm 2013 to increase the angle between plateau 2104 and the horizontal surface. Conversely, arm 2103 may be retracted all the way down to a book docking state 2300B by decreasing the angle between plateau 2104 and the horizontal surface.

[00127] In some cases, arm 2103 may have friction couplings configured to hold IHS 100 in any intermediate angle or position. The lateral edges of displays 101/102 may rest against the horizontal surface as arm 2103 swivels up and down. In some cases, base 2101 may be wedge shaped, with the height near its distal edge greater than the height near its proximal edge, in order to provide a natural display angle to the user in book docking mode 2300B.

[00128] As part of the docking process of FIG. 22B, a user may first place IHS 100 in laptop posture. The user may then align the back of second display 102 against positioning nib 2105. Again, the back of second display 102 may include detent 2202 configured to mate with nib 2105, and to align IHS 100 in response to it being positioned against the stop surface of plateau 2104. Second display 102 may also include magnetic device 2203 (with opposite polarity as magnetic device 2107) configured such that, when detent 2202 is aligned with nib 2105, magnetic device 2203 snaps or holds IHS 100 in place (in this case, magnetic device 2201 within first display 101 is not engaged).

[00129] As a result of the process of FIG. 22B, FIG. 23C shows IHS 100 and docking system 2100 in laptop docking mode 2300C. In some cases, arm 2103 may be actuated to hold plateau 2104 at a fixed distance from base 2101, for example, in order to provide leave a gap between plateau 2104 and base 2201 that is usable for cooling IHS 100.

[00130] It should be understood that various operations described herein may be implemented in software executed by logic or processing circuitry, hardware, or a combination thereof. The order in which each operation of a given method is performed may be changed, and various operations may be added, reordered, combined, omitted, modified, etc. It is intended that the invention(s) described herein embrace all such modifications and changes and, accordingly, the above description should be regarded in an illustrative rather than a restrictive sense.

[00131] Although the invention(s) is/are described herein with reference to specific embodiments, various modifications and changes can be made without departing from the scope of the present invention(s), as set forth in the claims below. Accordingly, the specification and figures are to be regarded in an illustrative rather than a restrictive sense, and all such modifications are intended to be included within the scope of the present invention(s). Any benefits, advantages, or solutions to problems that are described herein with regard to specific embodiments are not intended to be construed as a critical, required, or essential feature or element of any or all the claims.

[00132] Unless stated otherwise, terms such as “first” and “second” are used to arbitrarily distinguish between the elements such terms describe. Thus, these terms are not necessarily intended to indicate temporal or other prioritization of such elements. The terms “coupled” or “operably coupled” are defined as connected, although not necessarily directly, and not necessarily mechanically. The terms “a” and “an” are defined as one or more unless stated otherwise. The terms “comprise” (and any form of comprise, such as “comprises” and “comprising”), “have” (and any form of have, such as “has” and “having”), “include” (and any form of include, such as “includes” and “including”) and “contain” (and any form of contain, such as “contains” and “containing”) are open-ended linking verbs. As a result, a system, device, or apparatus that “comprises,” “has,” “includes” or “contains” one or more elements possesses those one or more elements but is not limited to possessing only those one or more elements. Similarly, a method or process that “comprises,” “has,” “includes” or “contains” one or more operations possesses those one or more operations but is not limited to possessing only those one or more operations.

## Claims

1. A dock, comprising:
  - a base;
  - a plateau configured to receive an Information Handling System (IHS); and
  - an arm coupling a distal edge of the base to a proximal edge of the plateau,wherein the arm rotates with respect to the base around a first axis to lift the plateau, wherein the plateau rotates with respect to the arm around a second axis to tilt the plateau, and wherein the second axis is parallel with respect to the first axis.
2. The dock of claim 1, wherein the plateau further comprises a magnetic device.
3. The dock of claim 2, wherein the magnetic device is positioned in the plateau in a direction perpendicular to the proximal edge of the plateau.
4. The dock of claim 1, wherein the plateau further comprises a positioning nib.
5. The dock of claim 4, further comprising a first row of terminals disposed in parallel with respect to the proximal edge of the plateau alongside a given edge of the positioning nib.
6. The dock of claim 4, further comprising a second row of terminals disposed perpendicularly with respect to the first row of terminals alongside another side of the positioning nib.
7. The dock of claim 4, wherein the IHS further comprises a first display coupled to a second display via a hinge.
8. The dock of claim 8, wherein the second display comprises a second magnetic device positioned to mate with the magnetic device and a second positioning nib positioned to mate with the positioning nib in the plateau when the plateau receives the IHS in laptop mode.

9. The dock of claim 9, wherein the first display comprises a third magnetic device positioned to mate with the magnetic device in the plateau when the plateau receives the IHS in dual-display mode in a portrait orientation.
10. The dock of claim 1, wherein the base further comprises a graphical processor configured to be coupled to the IHS in response to the IHS being received by the plateau.
11. The dock of claim 1, wherein the IHS further comprises:  
a processor; and  
a memory coupled to the processor, the memory having program instructions stored thereon that, upon execution by the processor, cause the IHS to: identify a docking state of the IHS.
12. The dock of claim 11, wherein the program instructions, upon execution by the processor, further cause the IHS to, based on the identification, produce a corresponding User Interface (UI) feature on the first or second displays.
13. The dock of claim 11, wherein the docking state is selected from the group consisting of: dual monitor mode, book mode, and laptop mode.
14. A method, comprising:  
coupling an Information Handling System (IHS) to a plateau of a dock, wherein a proximal edge of the plateau is coupled to a distal edge of a base via an arm, wherein the arm rotates with respect to the base around a first axis to lift the IHS, and wherein the plateau rotates with respect to the arm around a second axis to tilt the IHS;  
collapsing the arm into the base to enter a book mode; and  
extending the arm away from the base to enter a dual monitor mode.
15. The method of claim 14, wherein the plateau further comprises a magnetic device and a positioning nib.

16. The method of claim 15, wherein the IHS further comprises a first display coupled to a second display via a hinge, and wherein the second display comprises a second magnetic device positioned to mate with the magnetic device and a second positioning nib positioned to mate with the positioning nib when the IHS is in laptop mode.
17. The method of claim 16, wherein the first display comprises a third magnetic device positioned to mate with the magnetic device when the IHS is in dual-display mode.
18. A hardware memory device having program instructions stored thereon that, upon execution by a processor of an Information Handling System (IHS), cause the IHS to:
- identify a state of the IHS relative to a dock, wherein the dock further comprises:
    - a base;
    - a plateau configured to receive the IHS; and
    - an arm coupling a distal edge of the base to a proximal edge of the plateau, wherein the arm rotates with respect to the base around a first axis to lift the plateau, wherein the plateau rotates with respect to the arm around a second axis to tilt the plateau, and wherein the second axis is parallel with respect to the first axis;
  - and
  - based on the identification, enable a connector between the plateau and the IHS.
19. The hardware memory device of claim 19, wherein the plateau further comprises a magnetic device and a positioning nib, wherein the IHS further comprises a first display coupled to a second display via a hinge, and wherein the second display comprises a second magnetic device positioned to mate with the magnetic device and a second positioning nib positioned to mate with the positioning nib when the IHS is in laptop mode.
20. The hardware memory device of claim 19, wherein the first display comprises a third magnetic device positioned to mate with the magnetic device when the IHS is in dual-display mode.

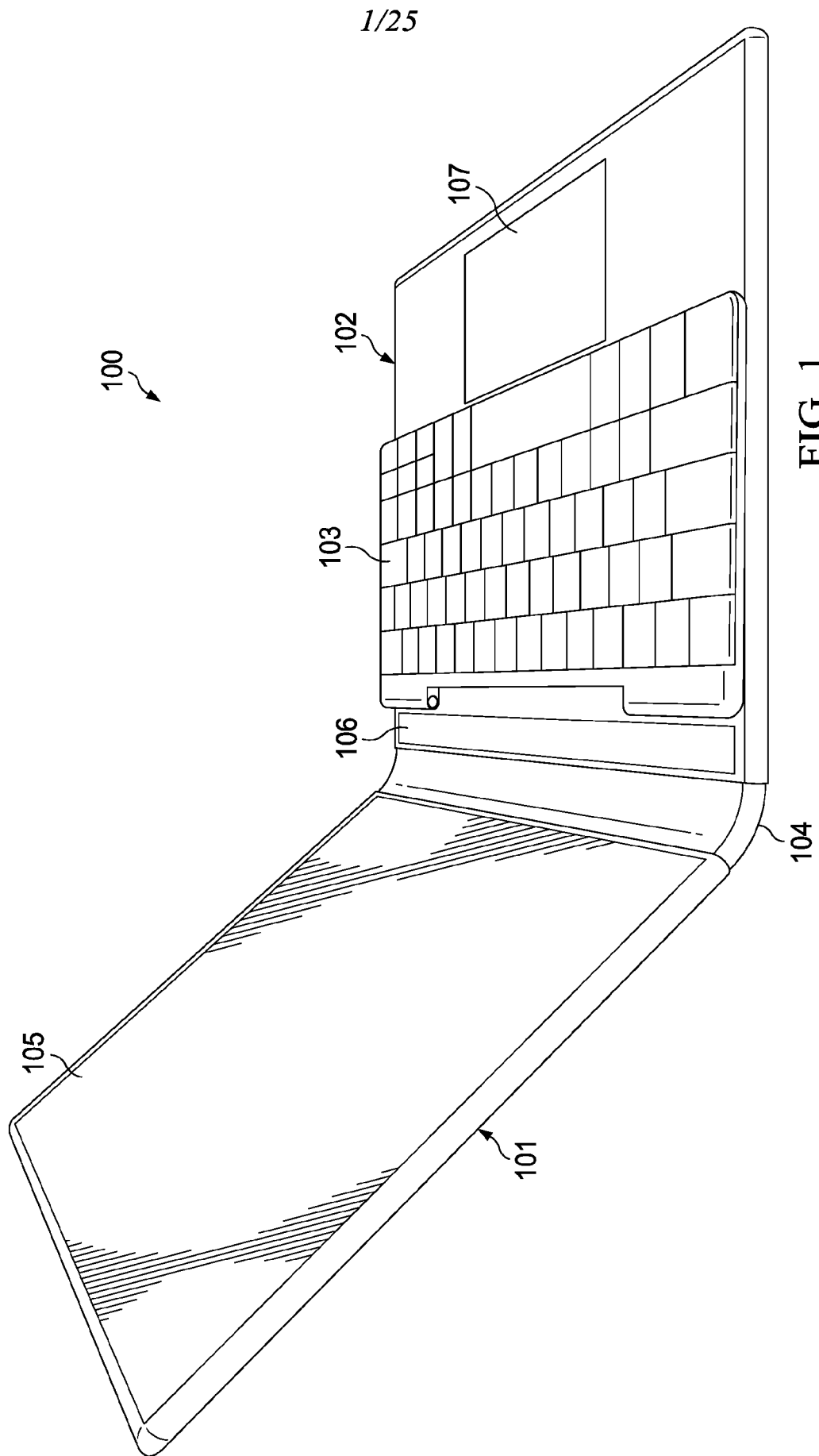

FIG. 1

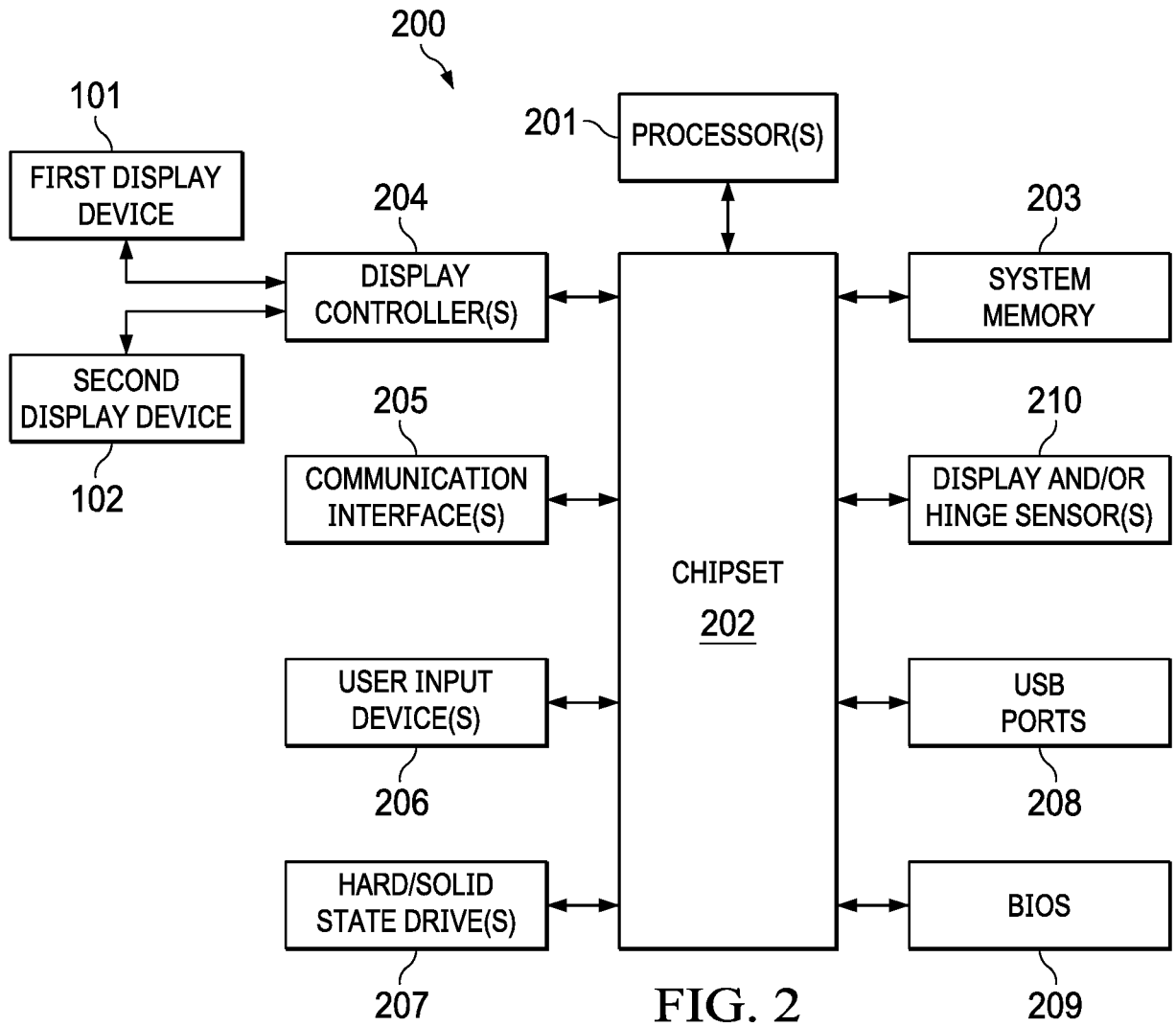

FIG. 2

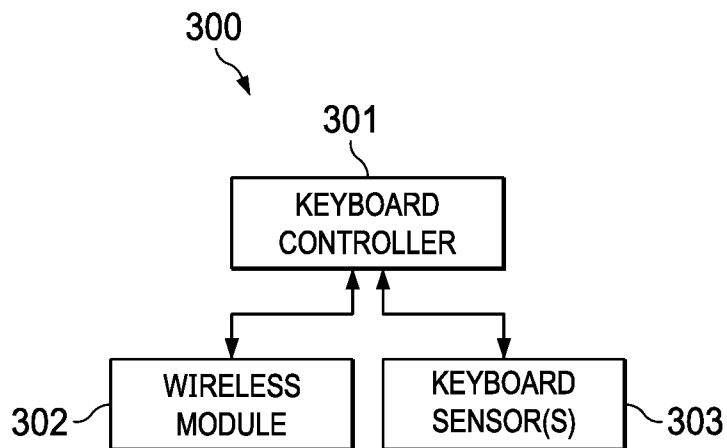

FIG. 3

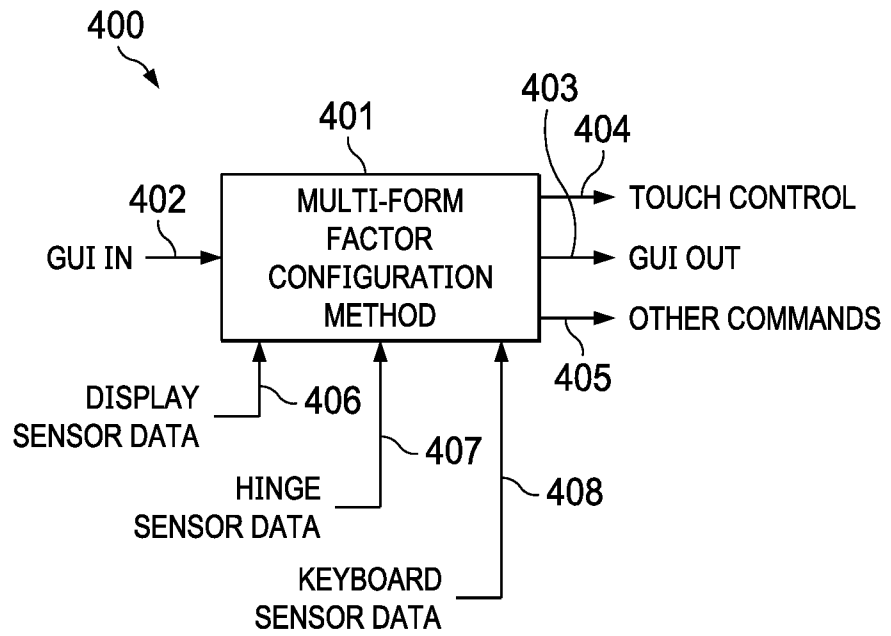

FIG. 4

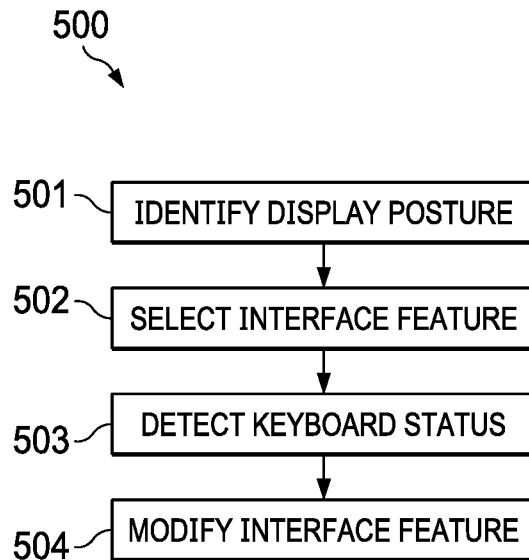

FIG. 5

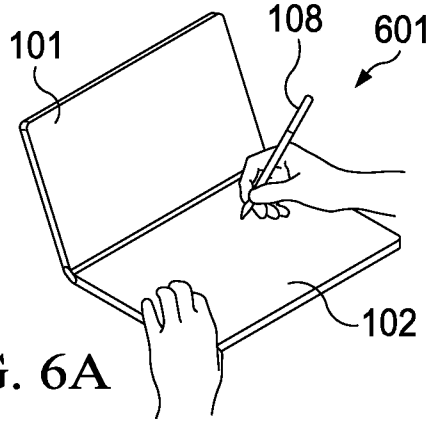

FIG. 6A

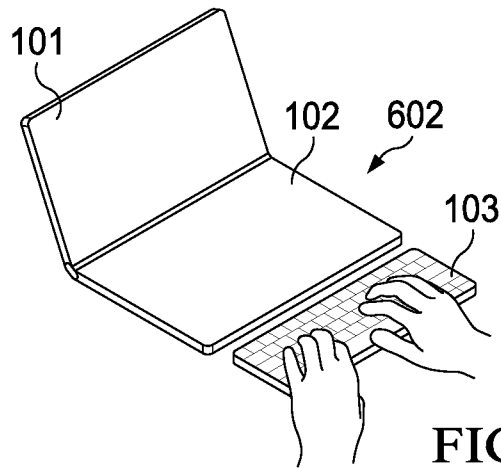

FIG. 6B

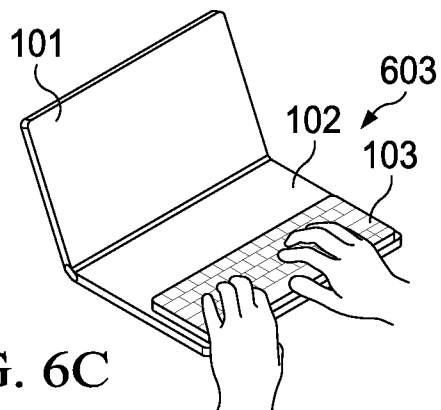
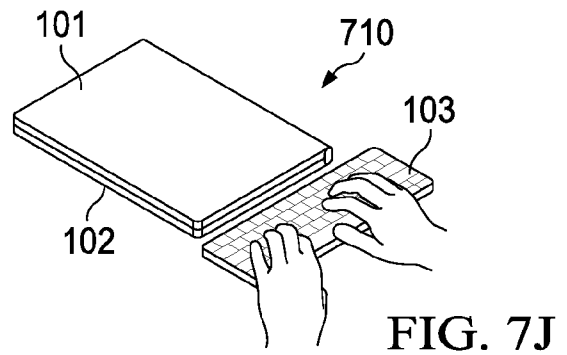
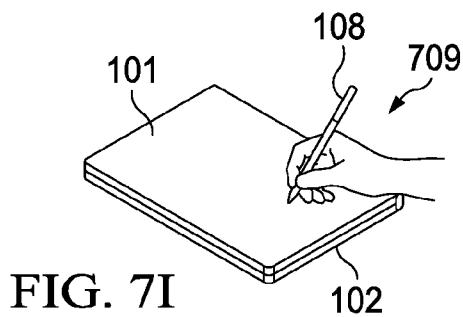
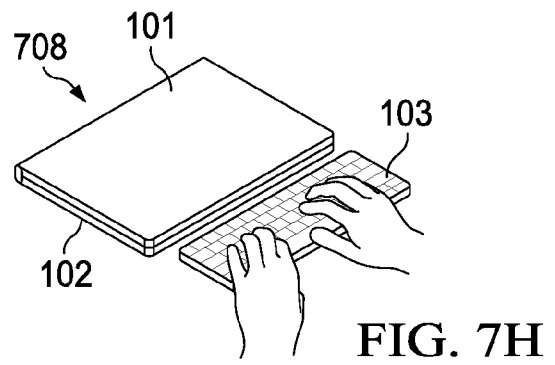
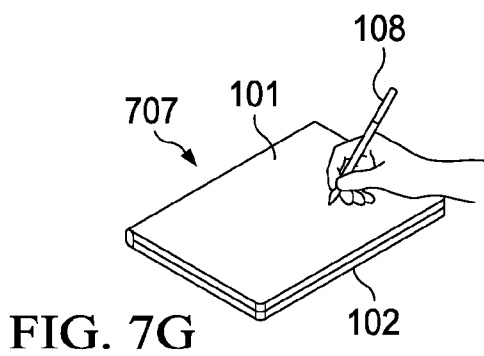
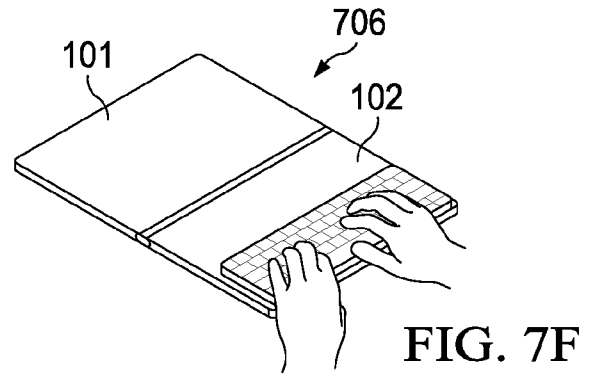
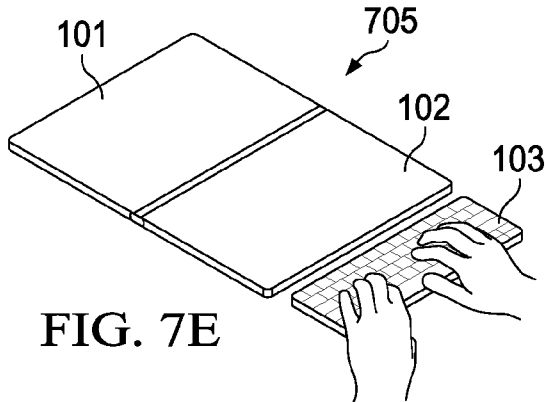
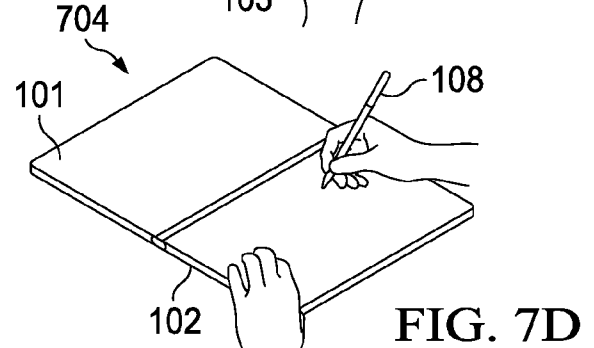
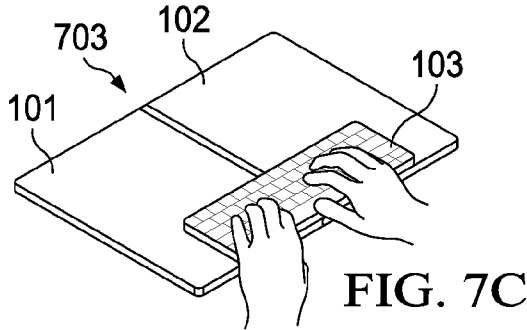
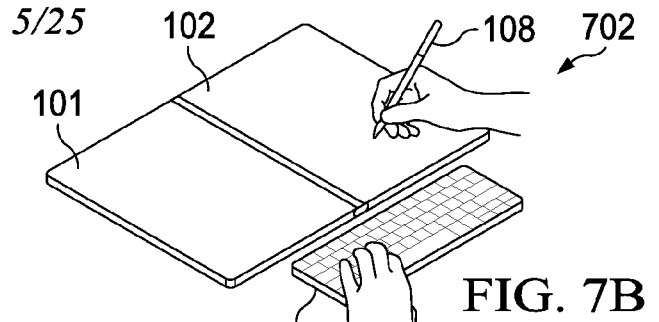
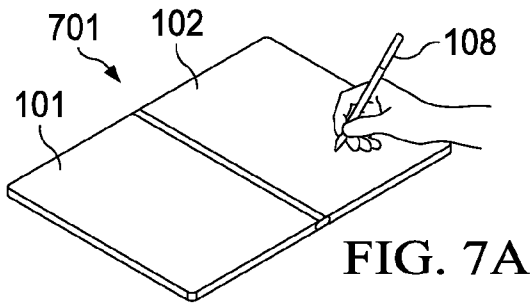

FIG. 6C



6/25

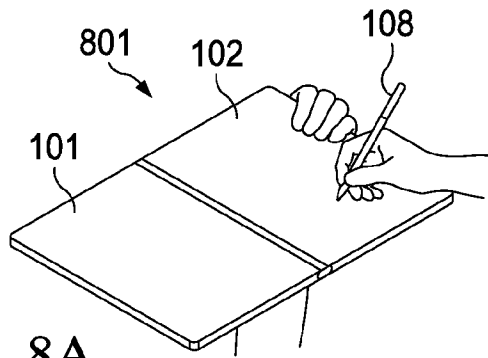

FIG. 8A

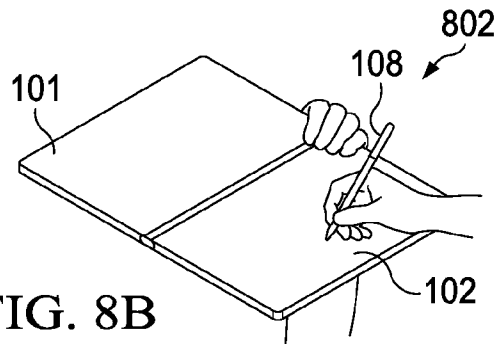

FIG. 8B

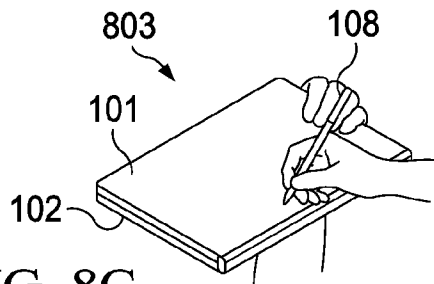

FIG. 8C

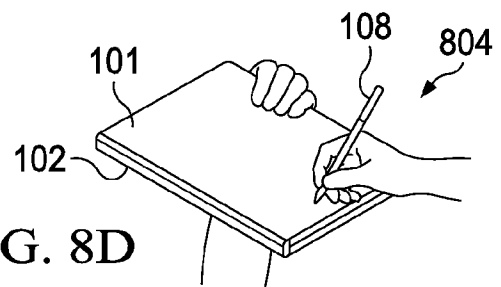

FIG. 8D

7/25

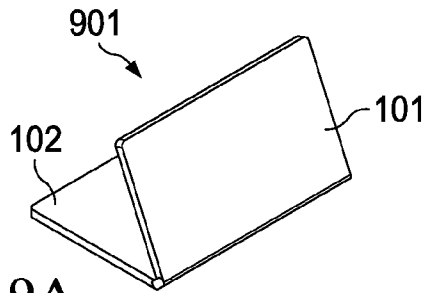

FIG. 9A

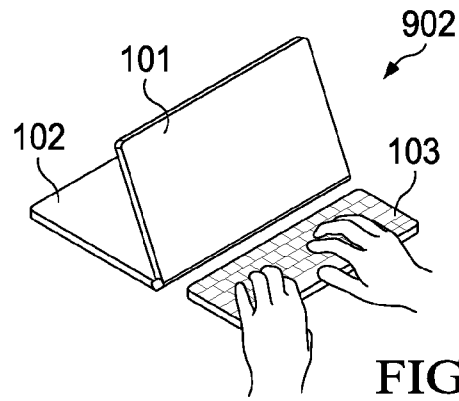

FIG. 9B

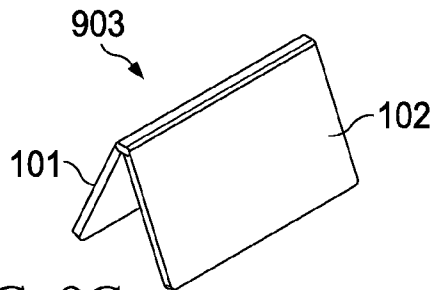

FIG. 9C

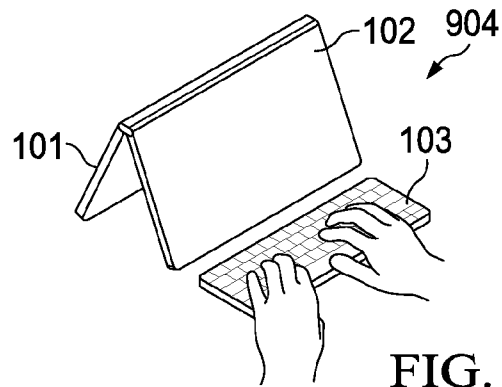

FIG. 9D

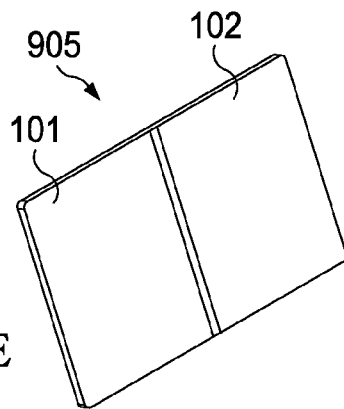

FIG. 9E

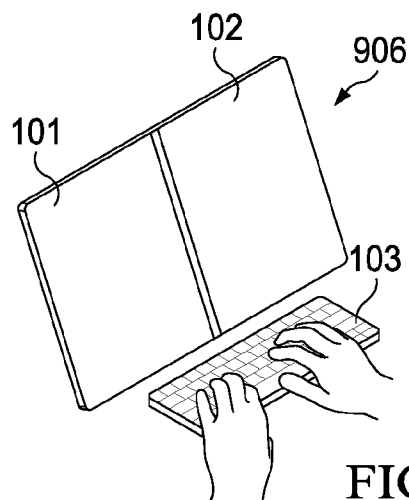

FIG. 9F

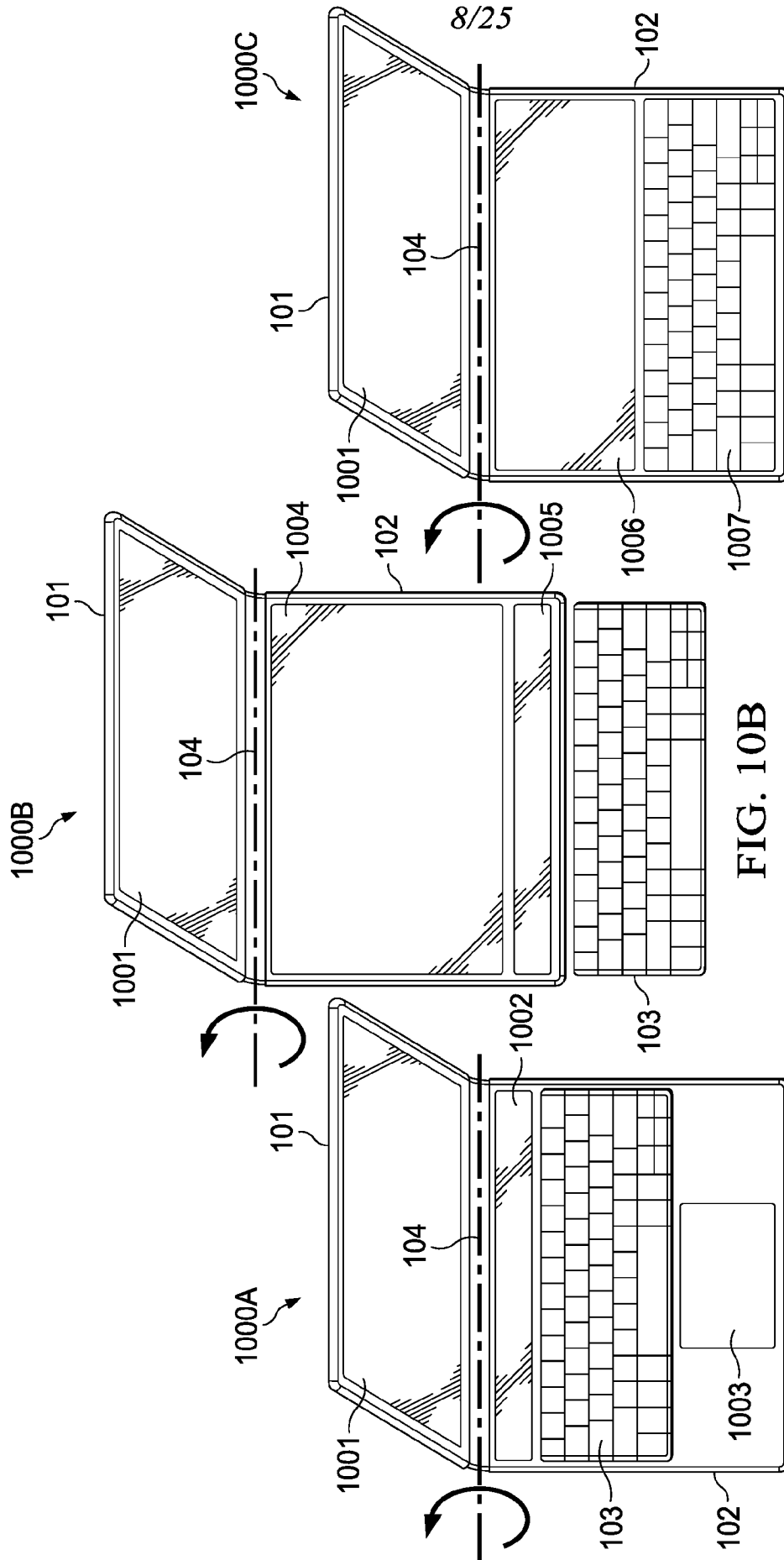
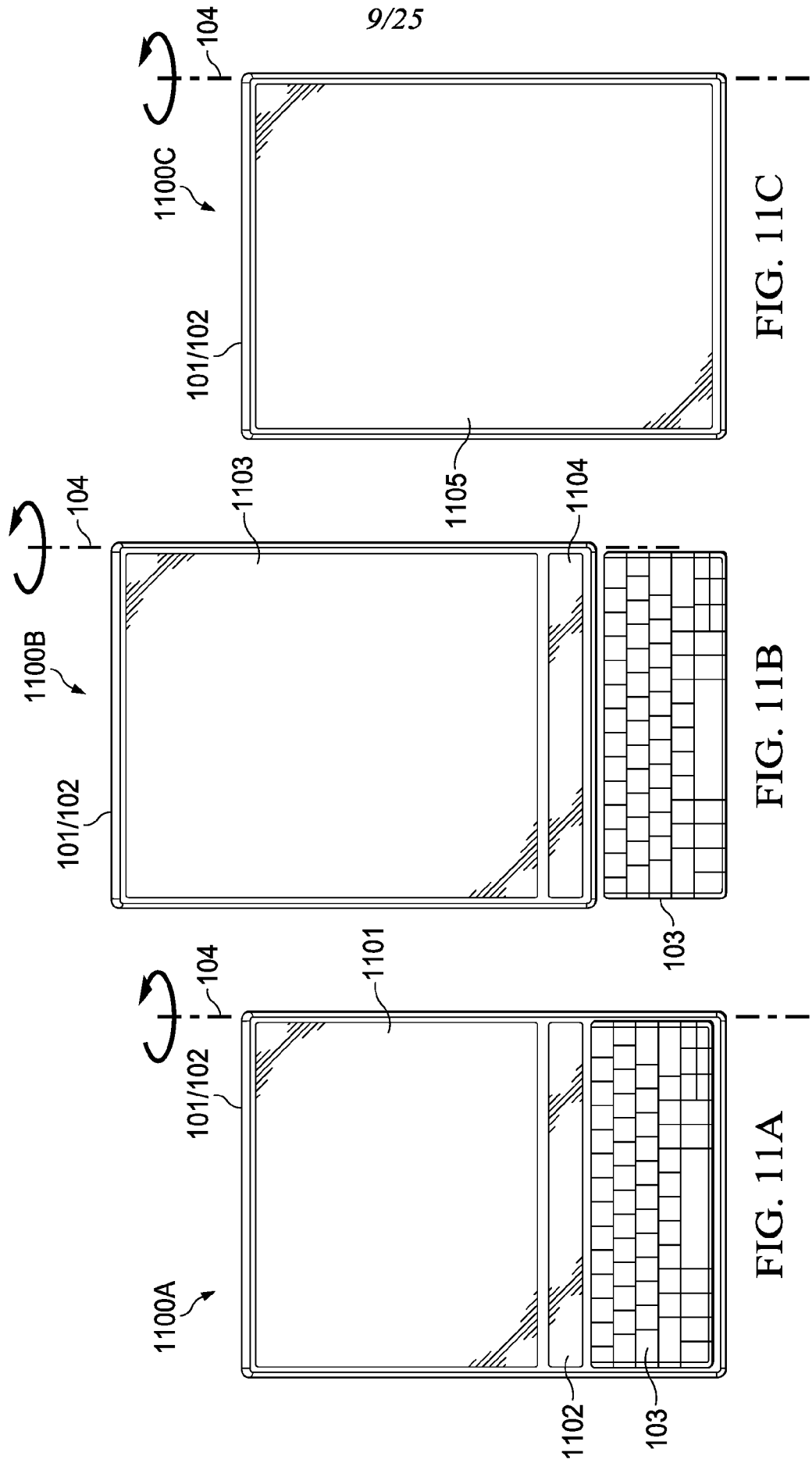

FIG. 10C

FIG. 10B

FIG. 10A



10/25

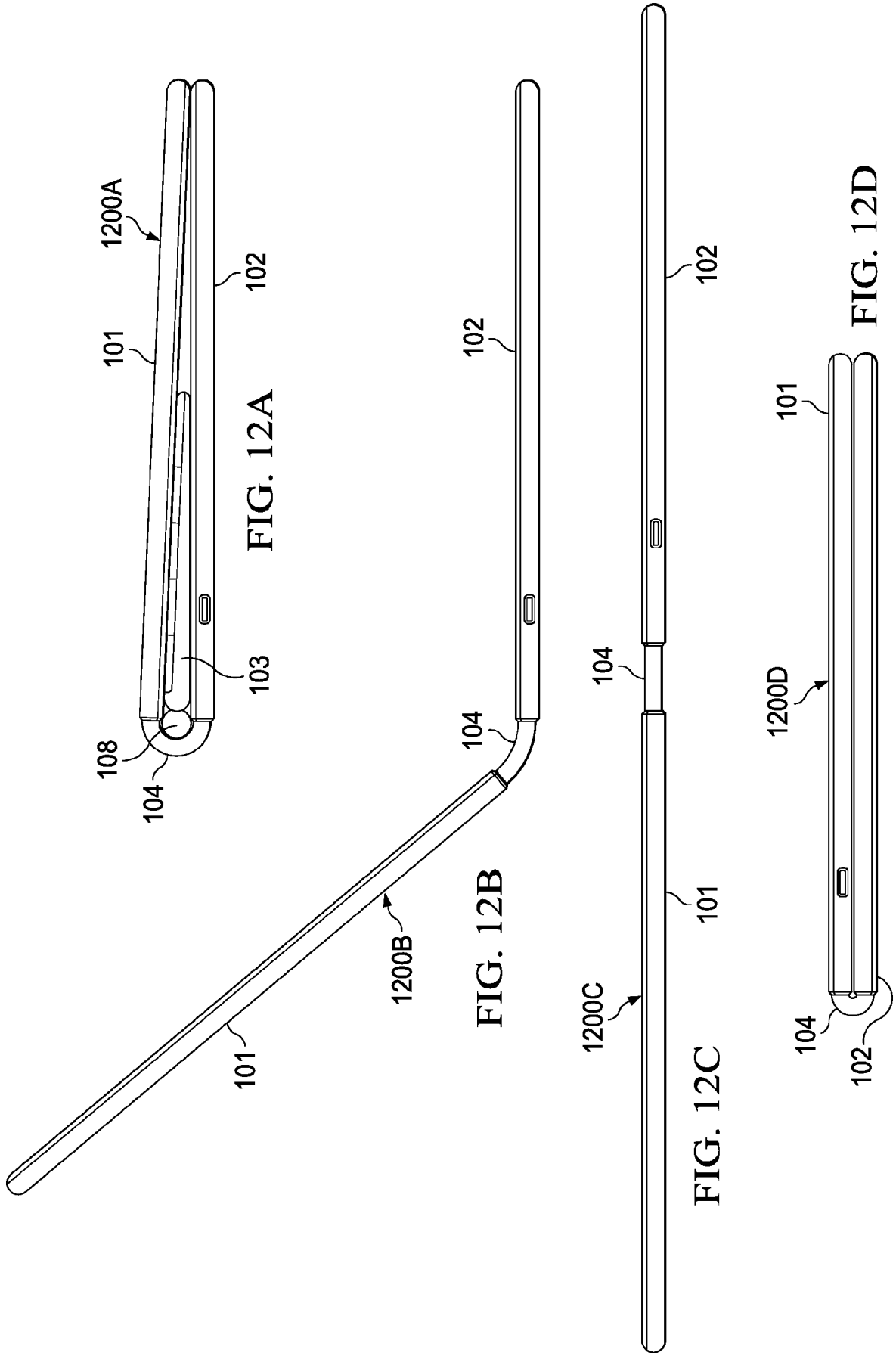

11/25

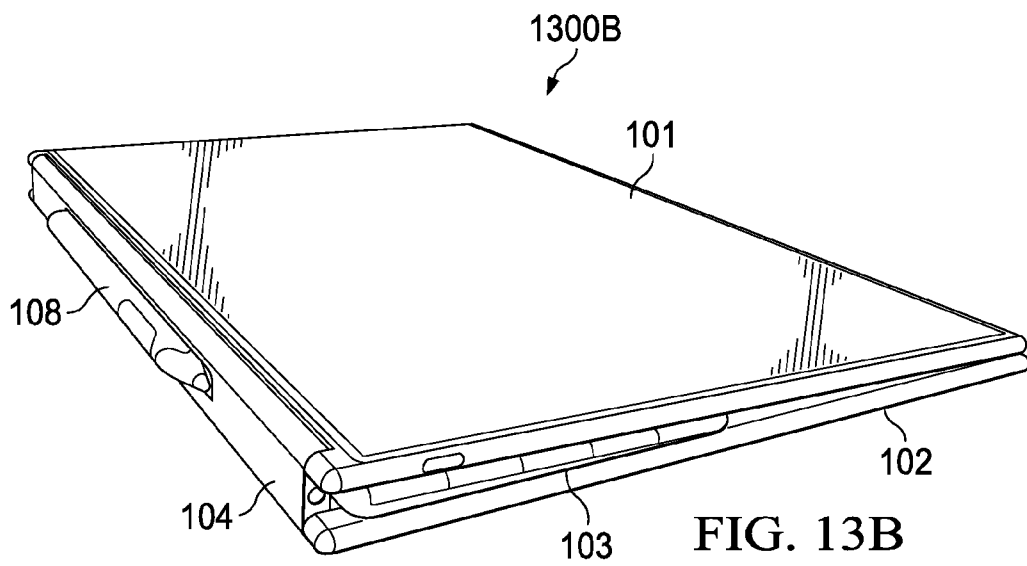
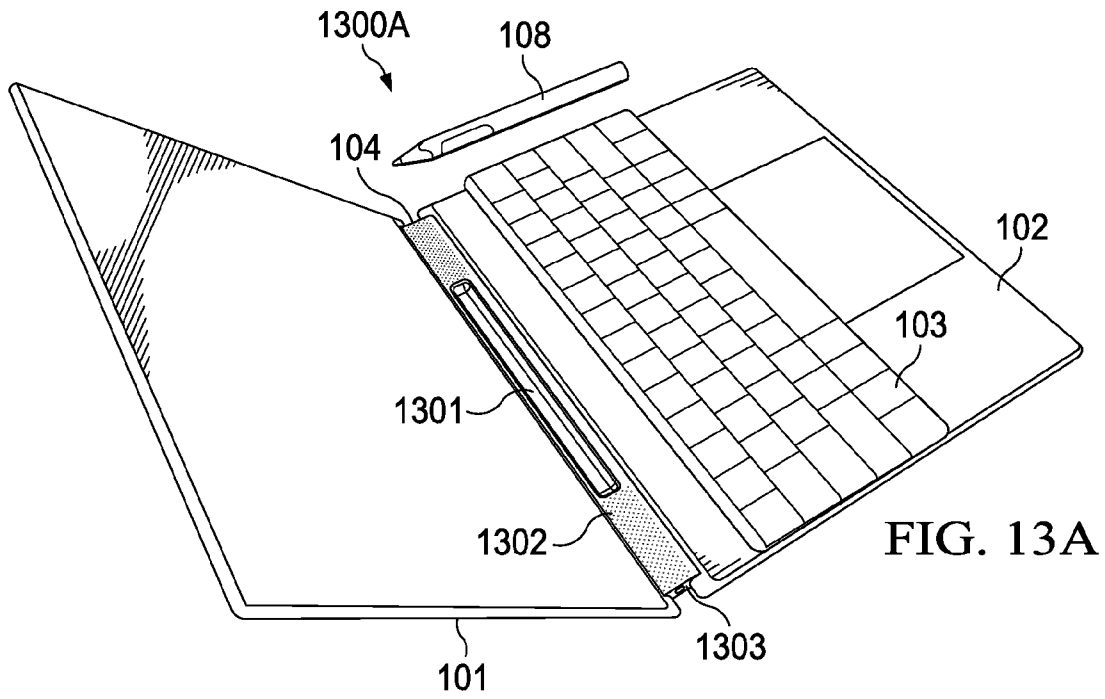

12/25

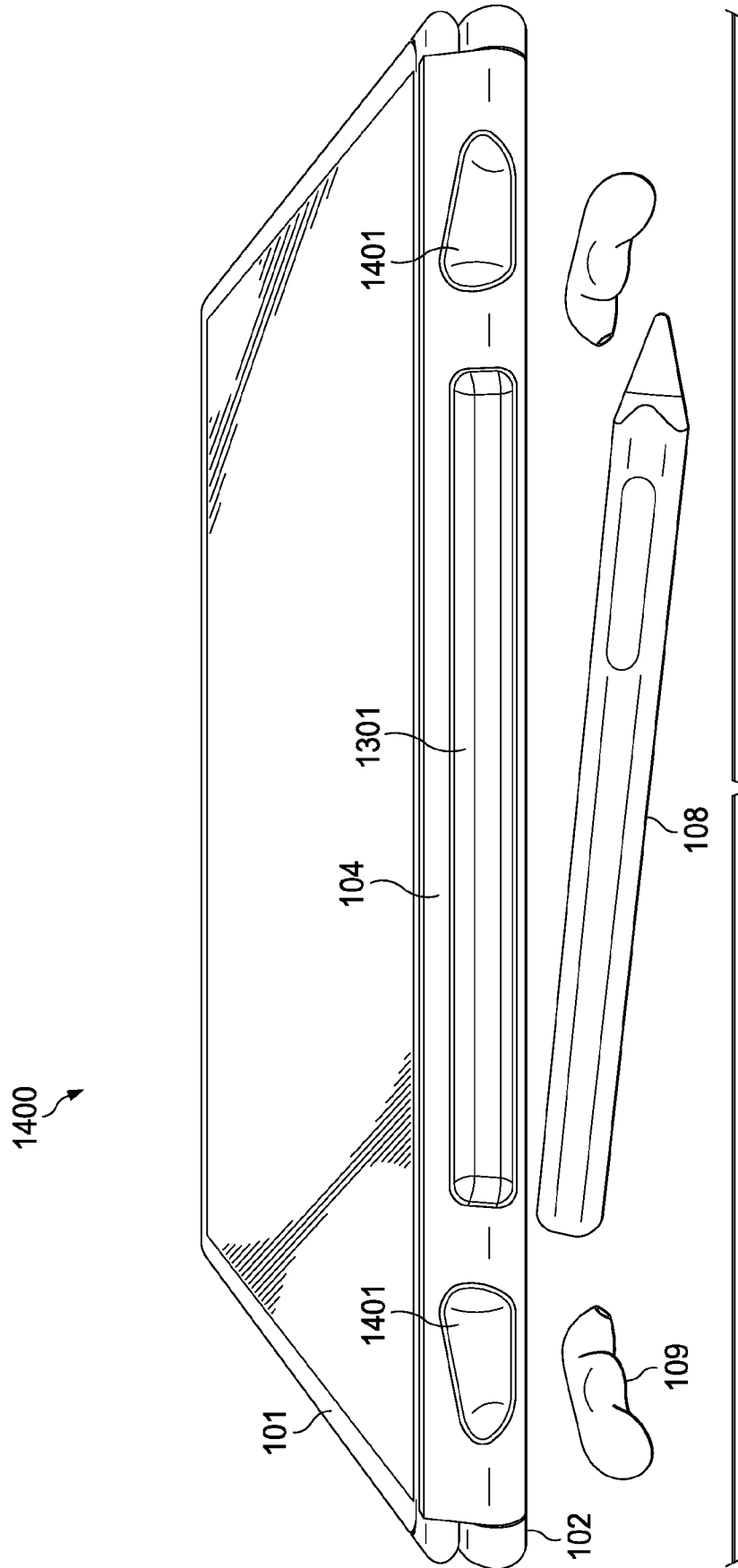

FIG. 14

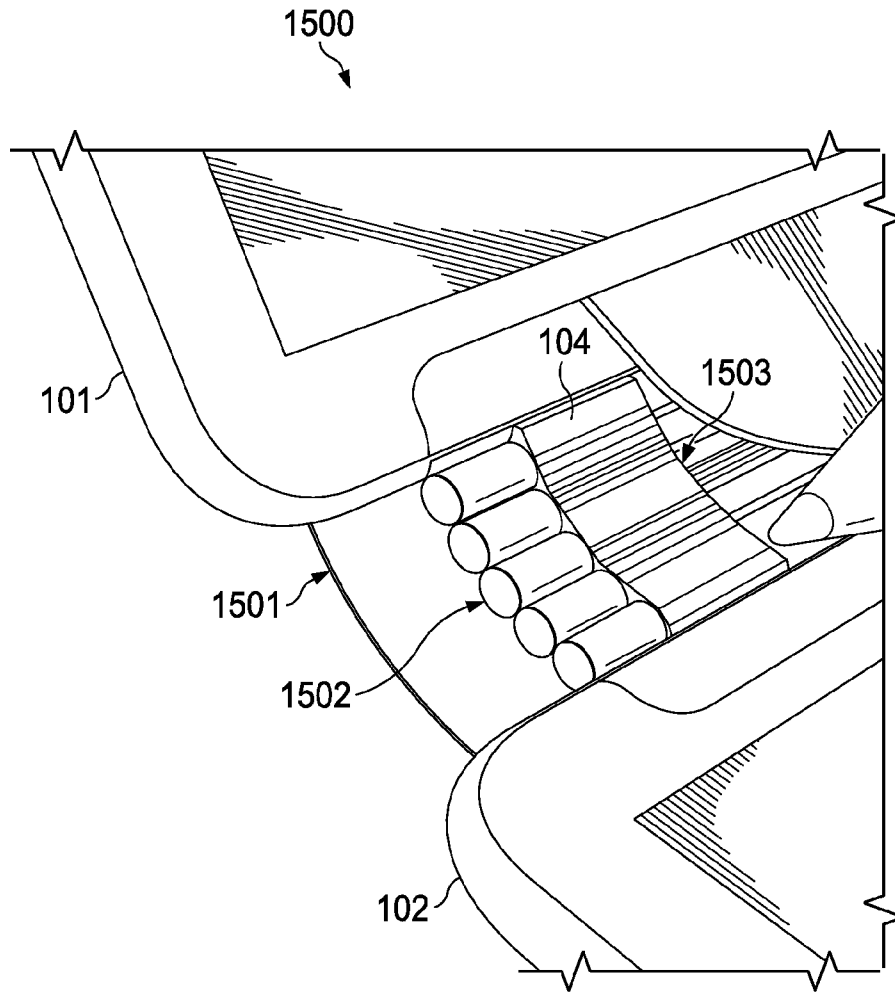

FIG. 15

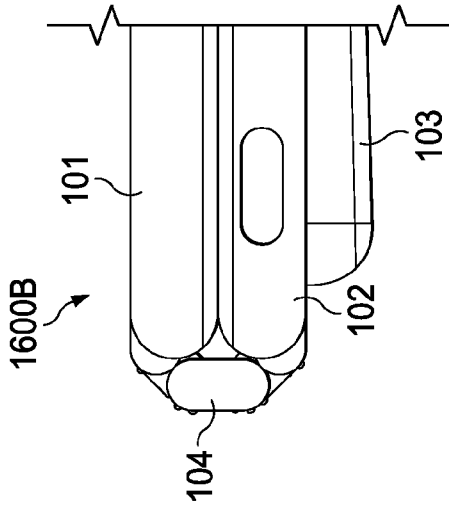

FIG. 16B

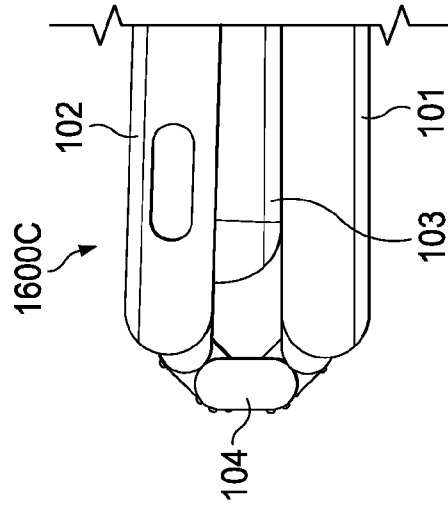

FIG. 16C

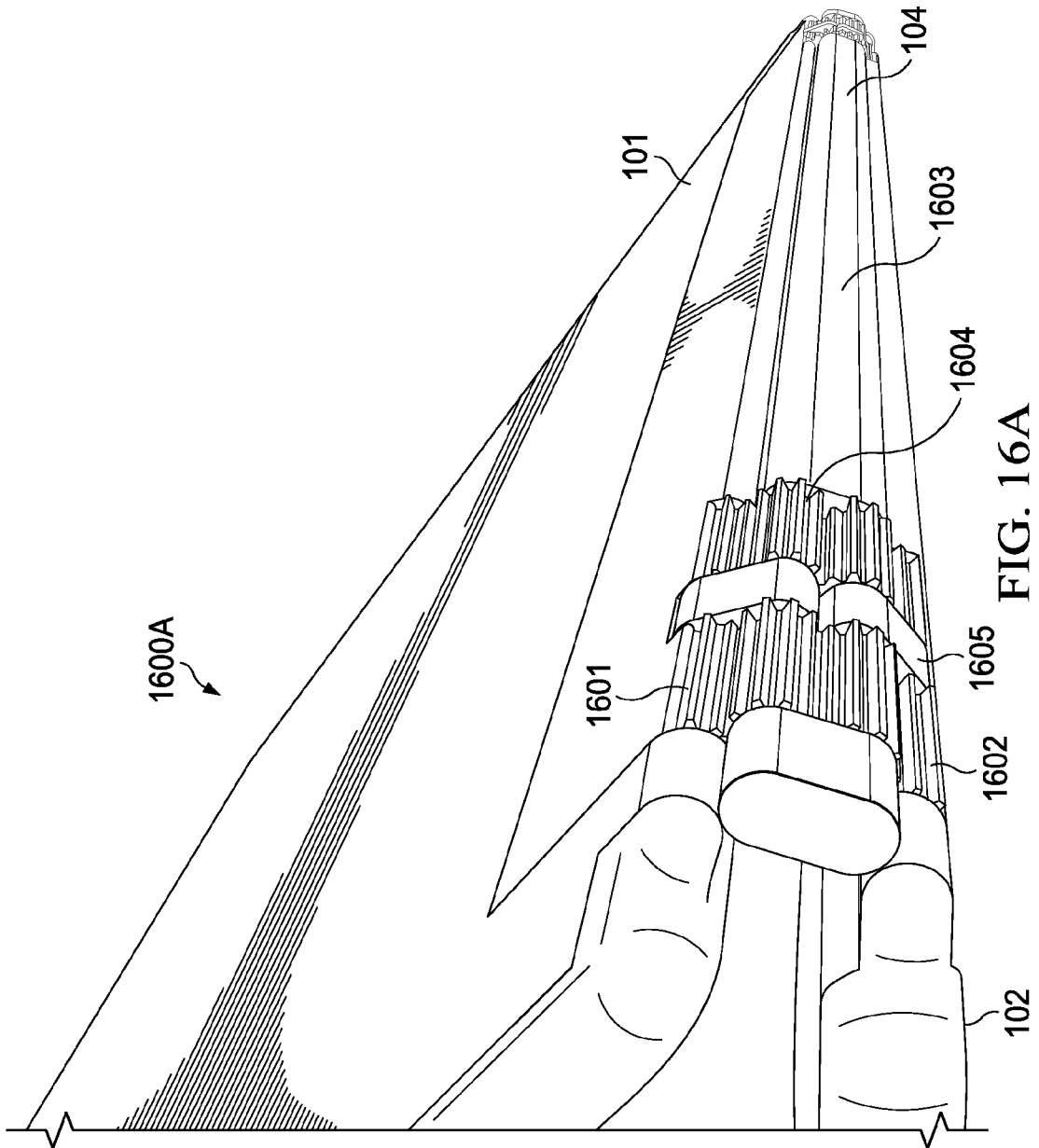

FIG. 16A

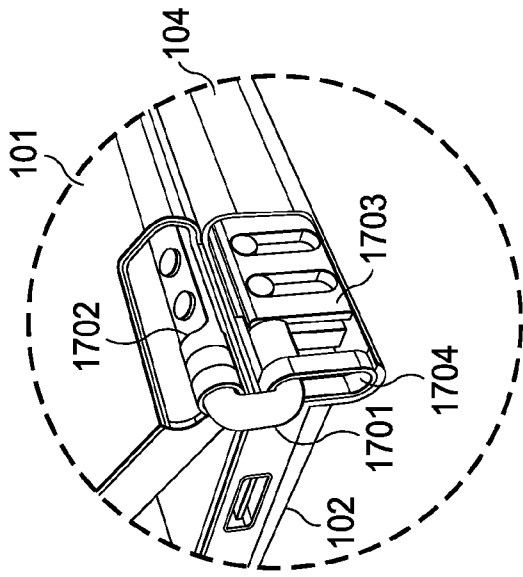

FIG. 17B

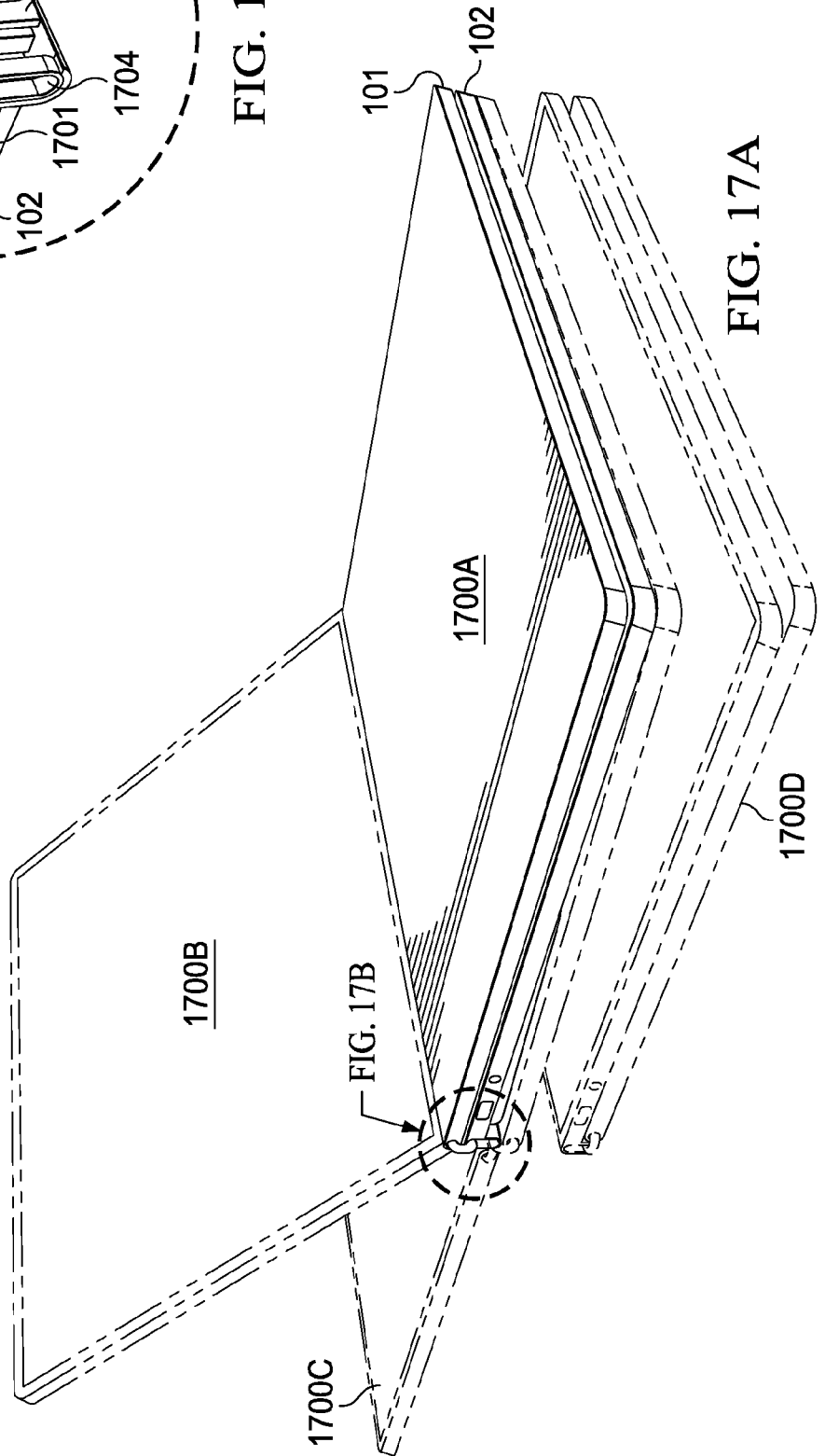

FIG. 17A

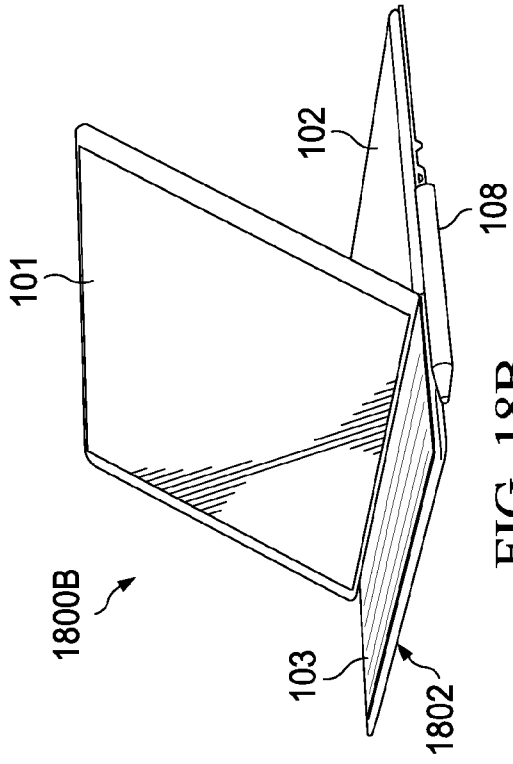

FIG. 18B

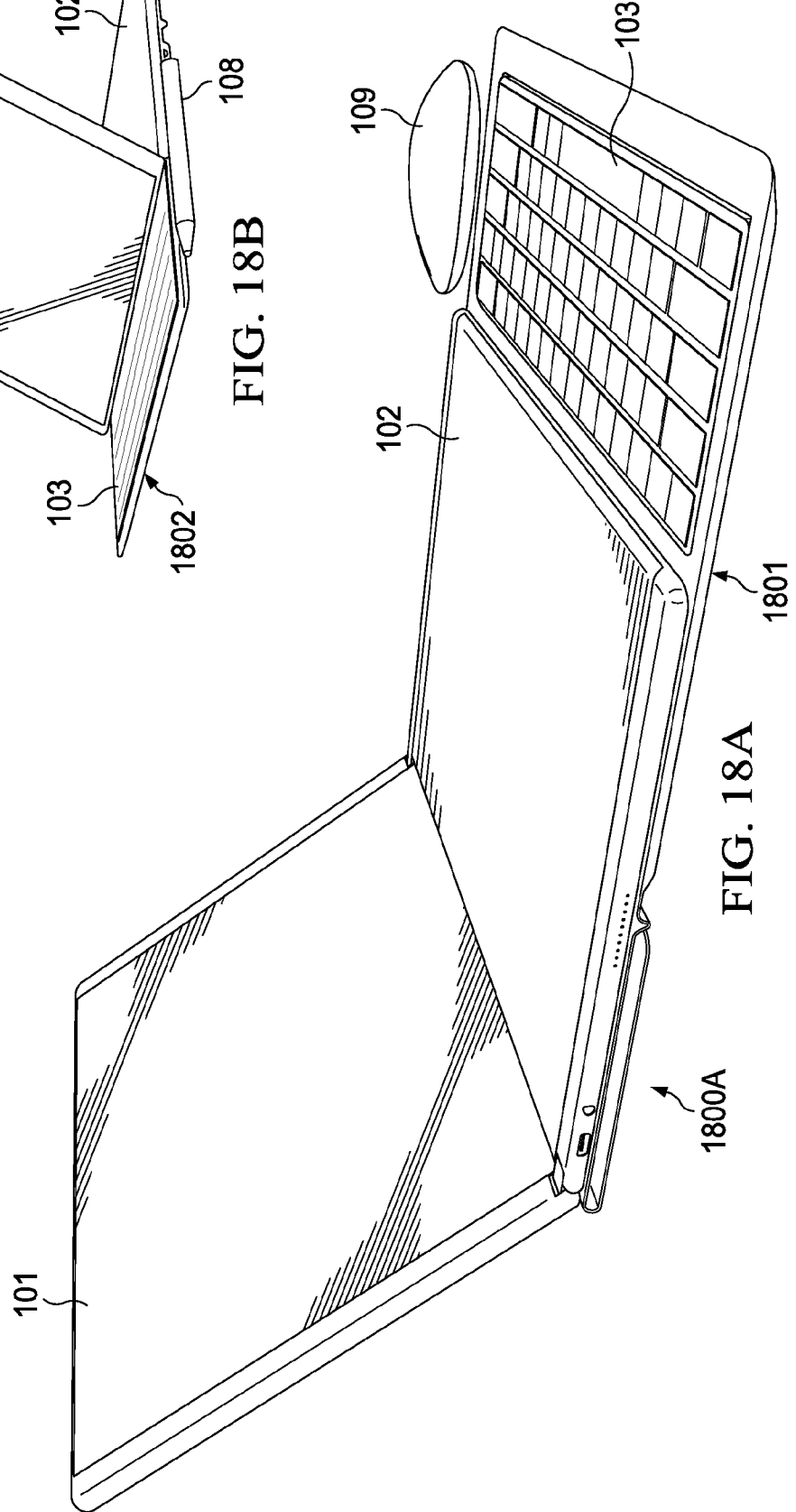

FIG. 18A

17/25

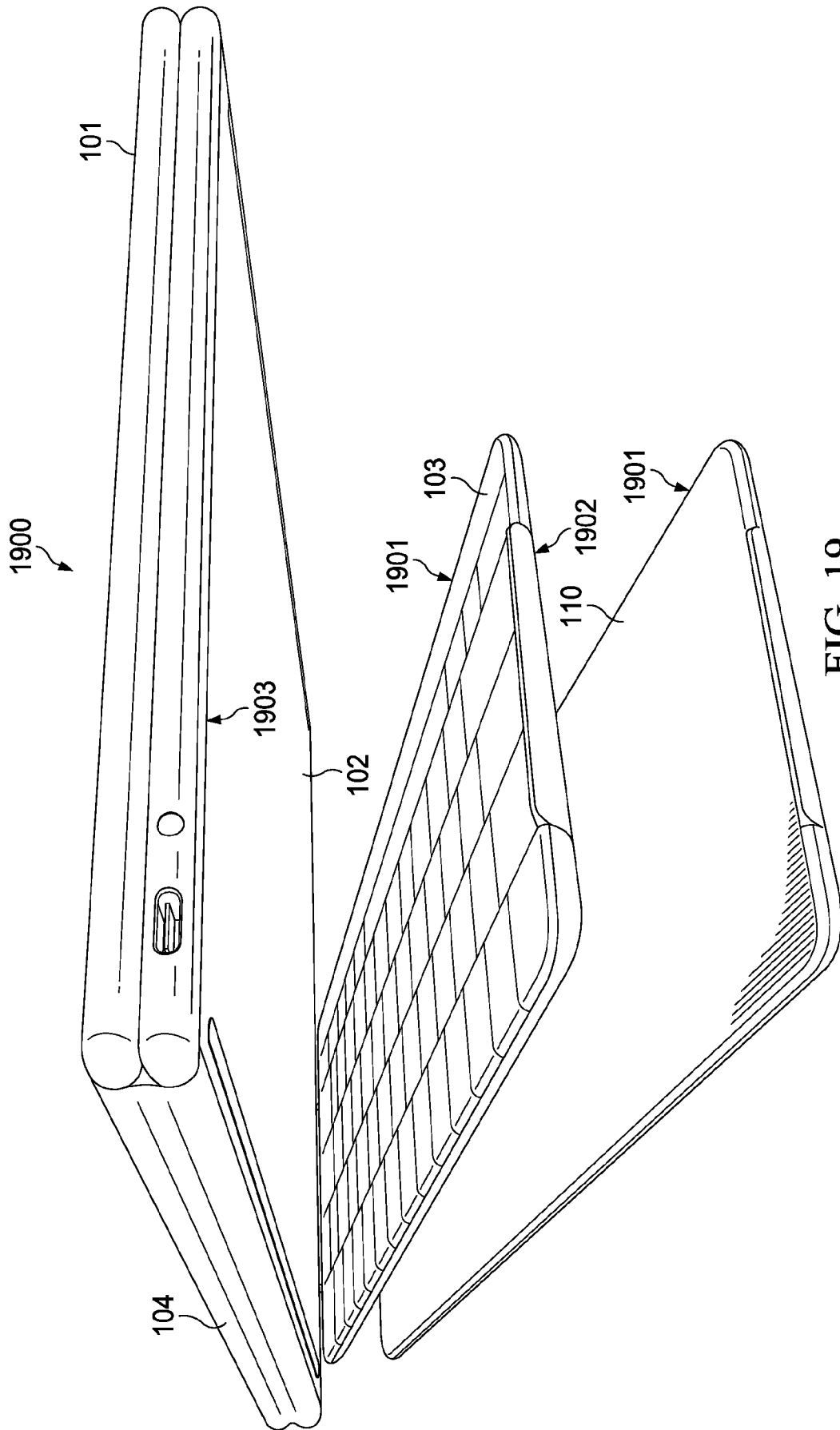

FIG. 19

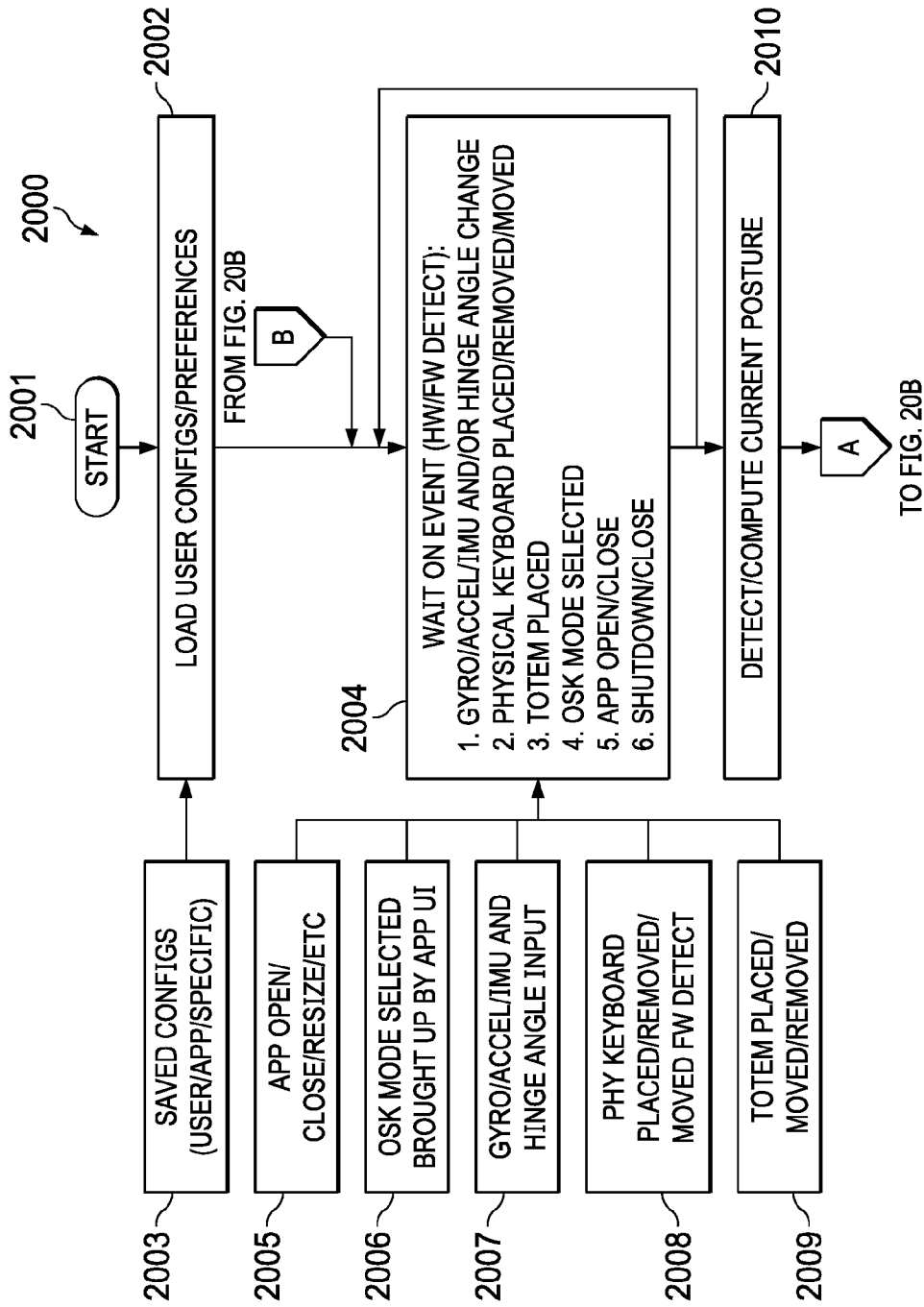

FIG. 20A

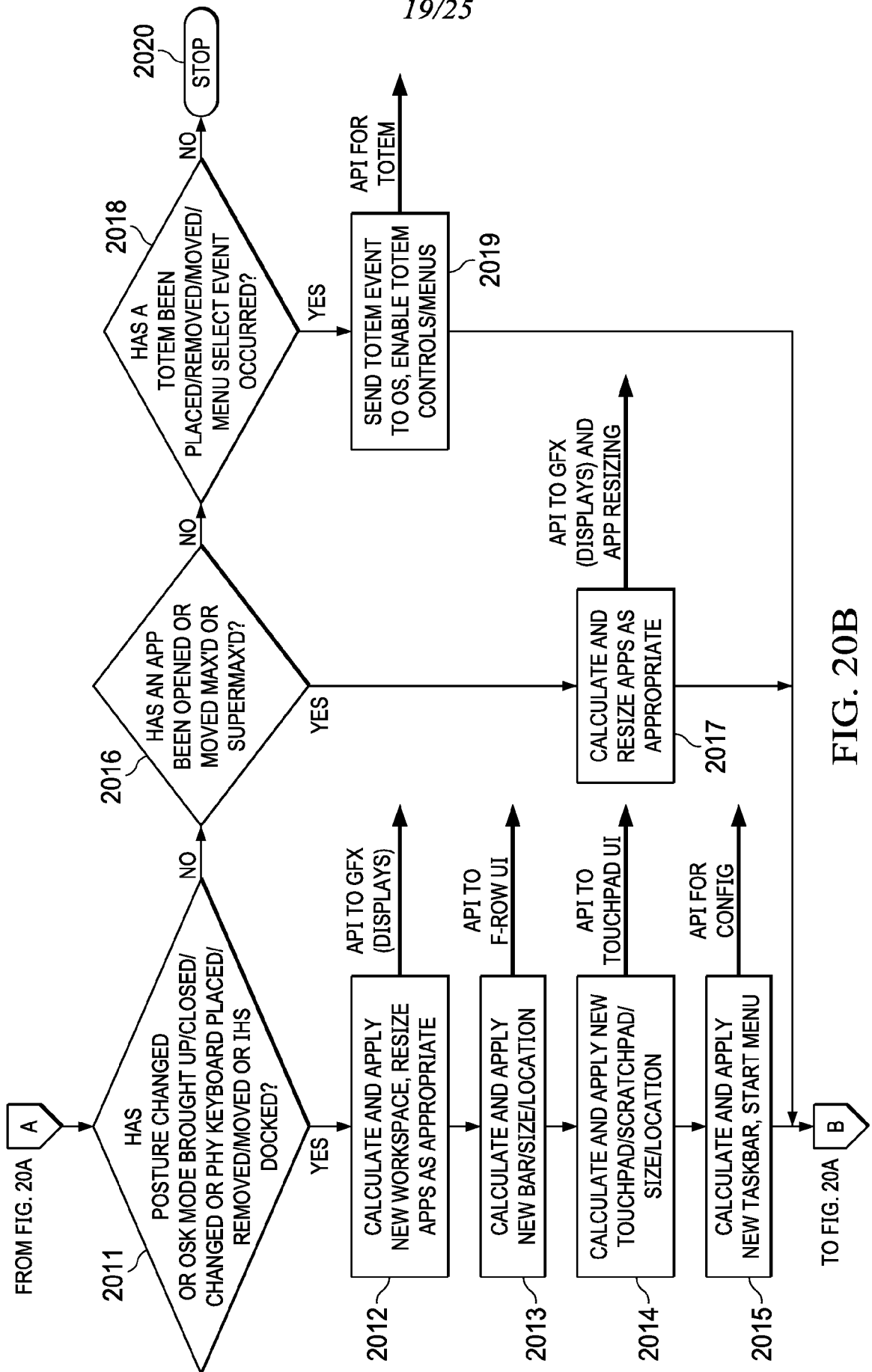

FIG. 20B

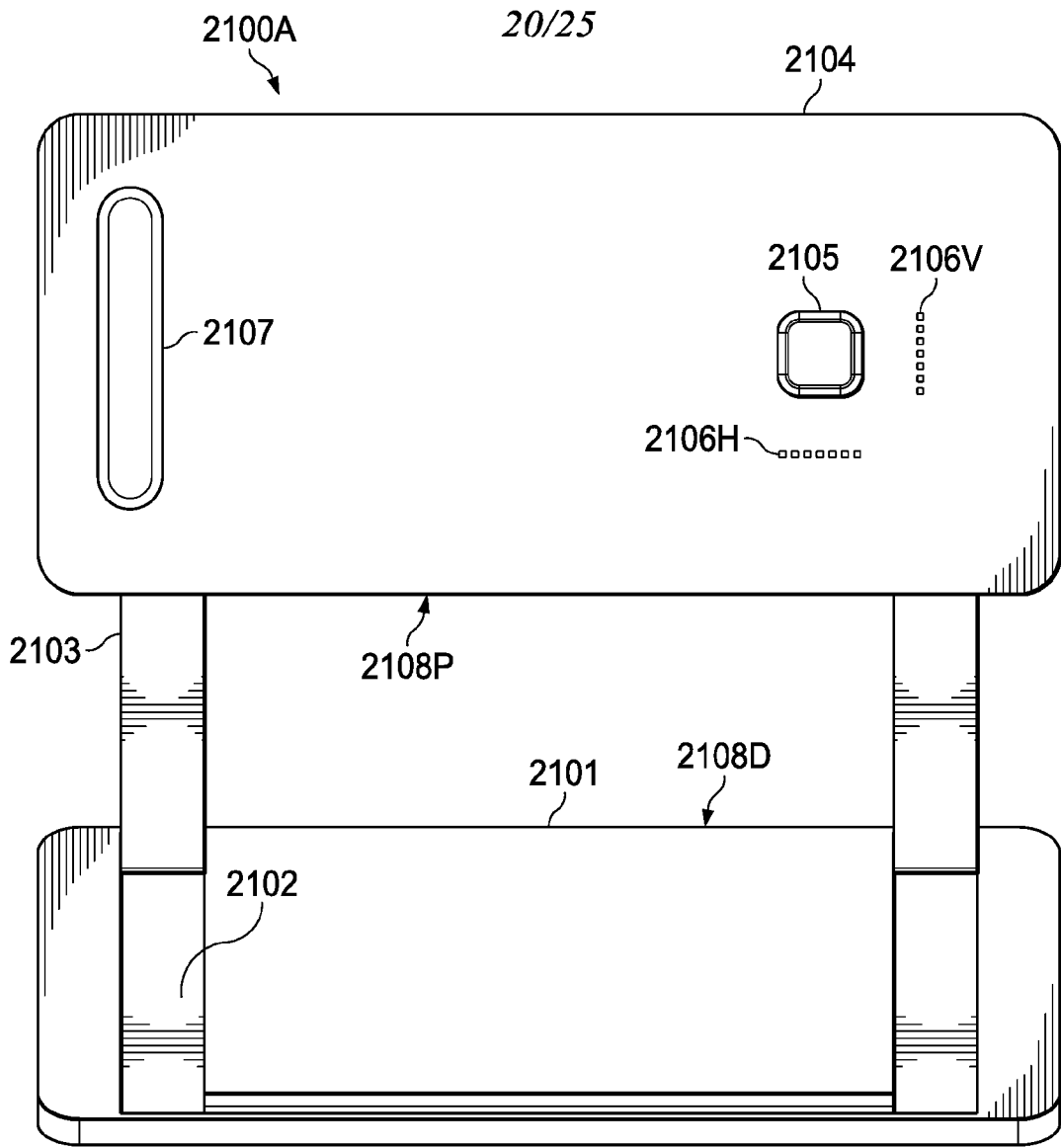

FIG. 21A

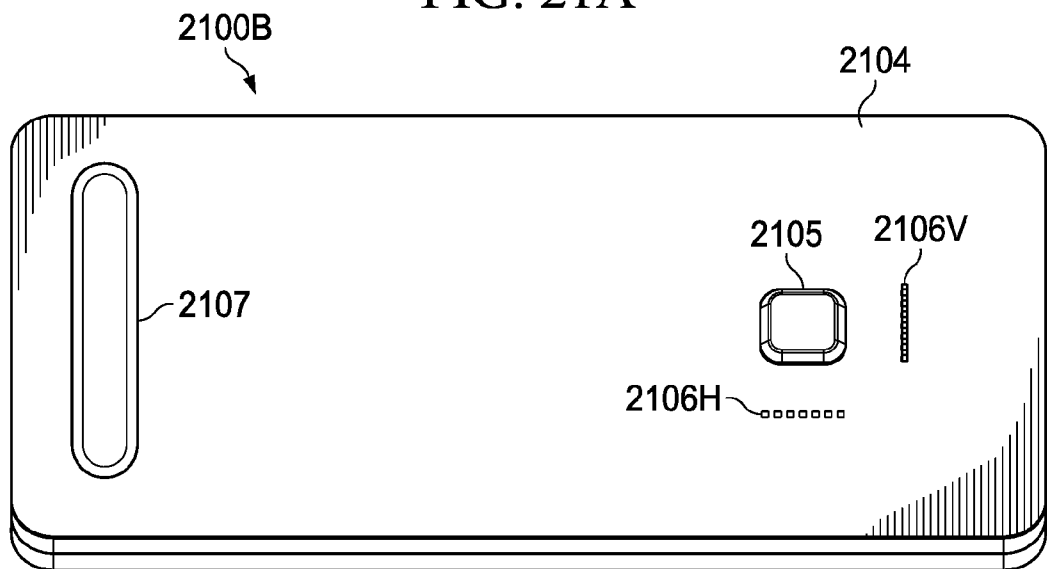

FIG. 21B

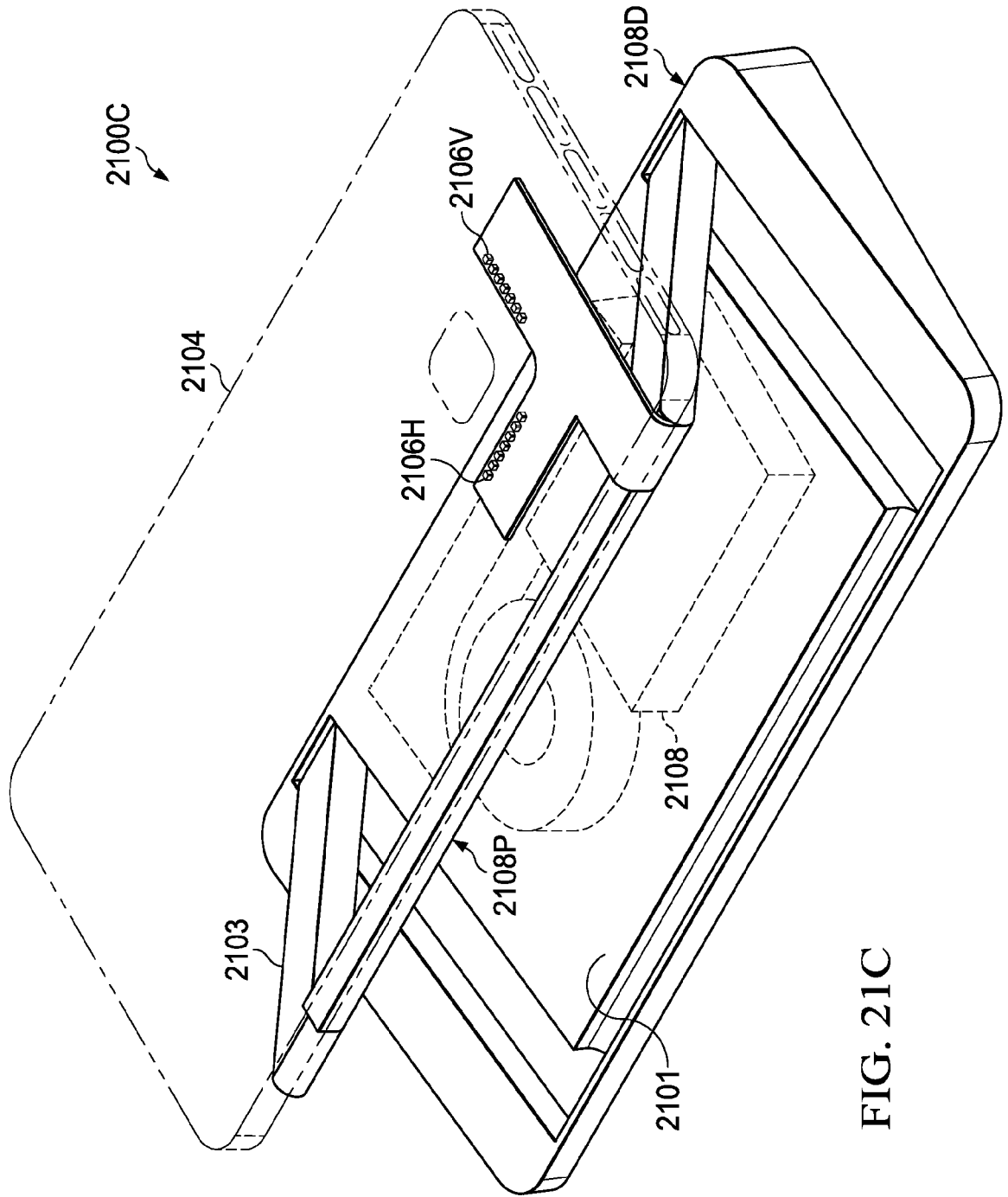

FIG. 21C

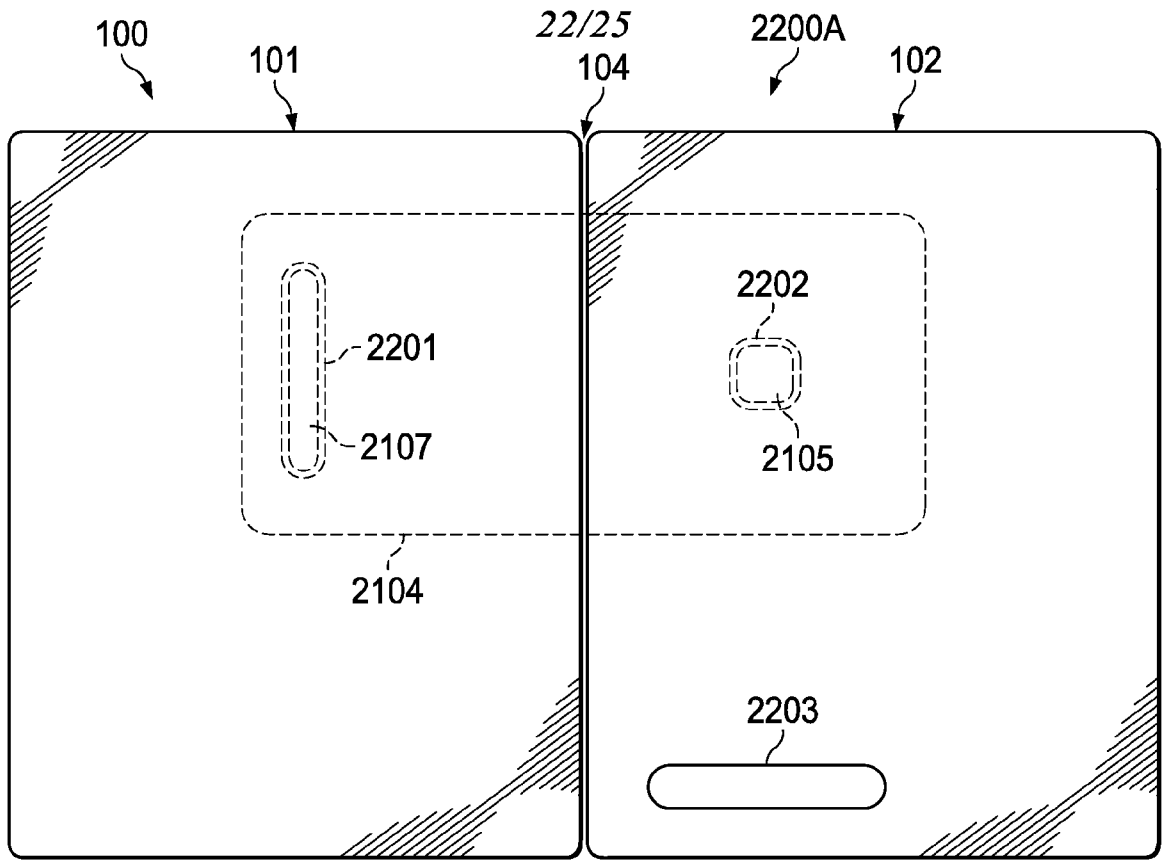

FIG. 22A

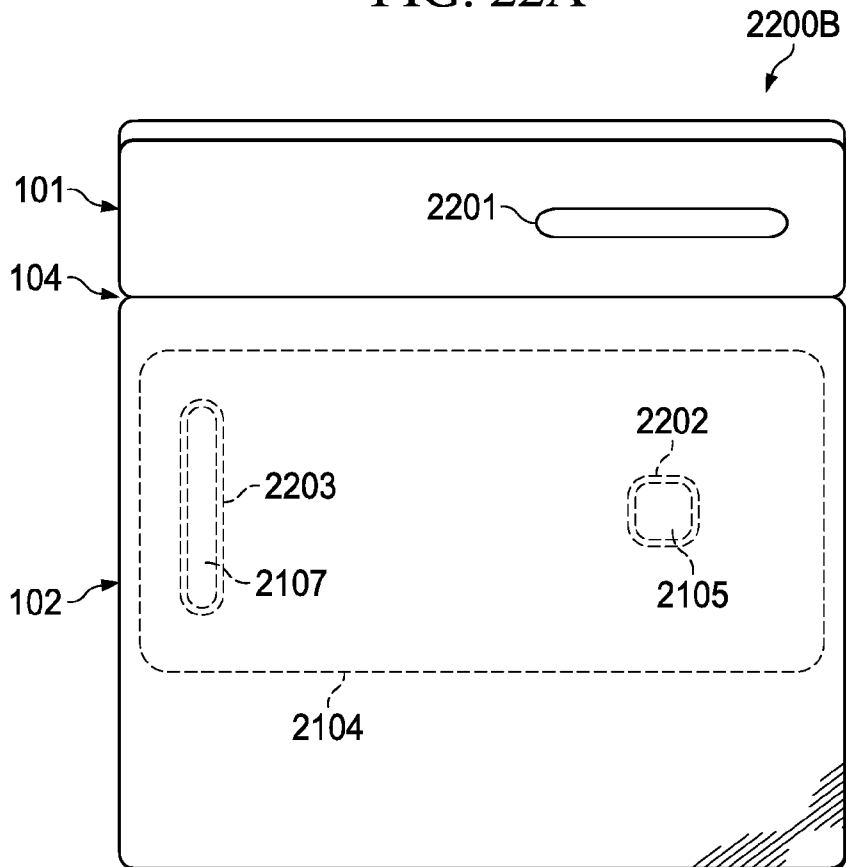

FIG. 22B

23/25

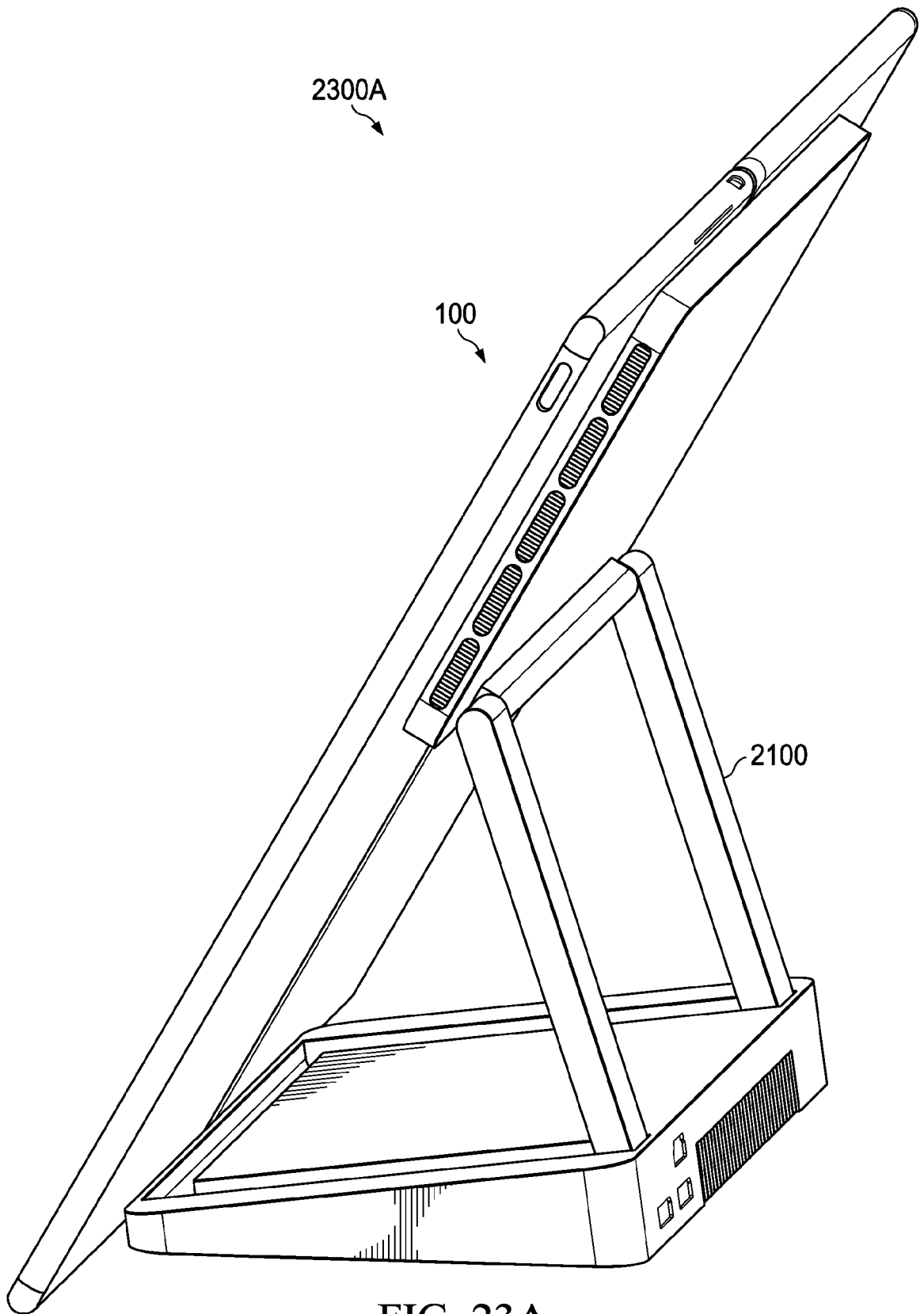

FIG. 23A

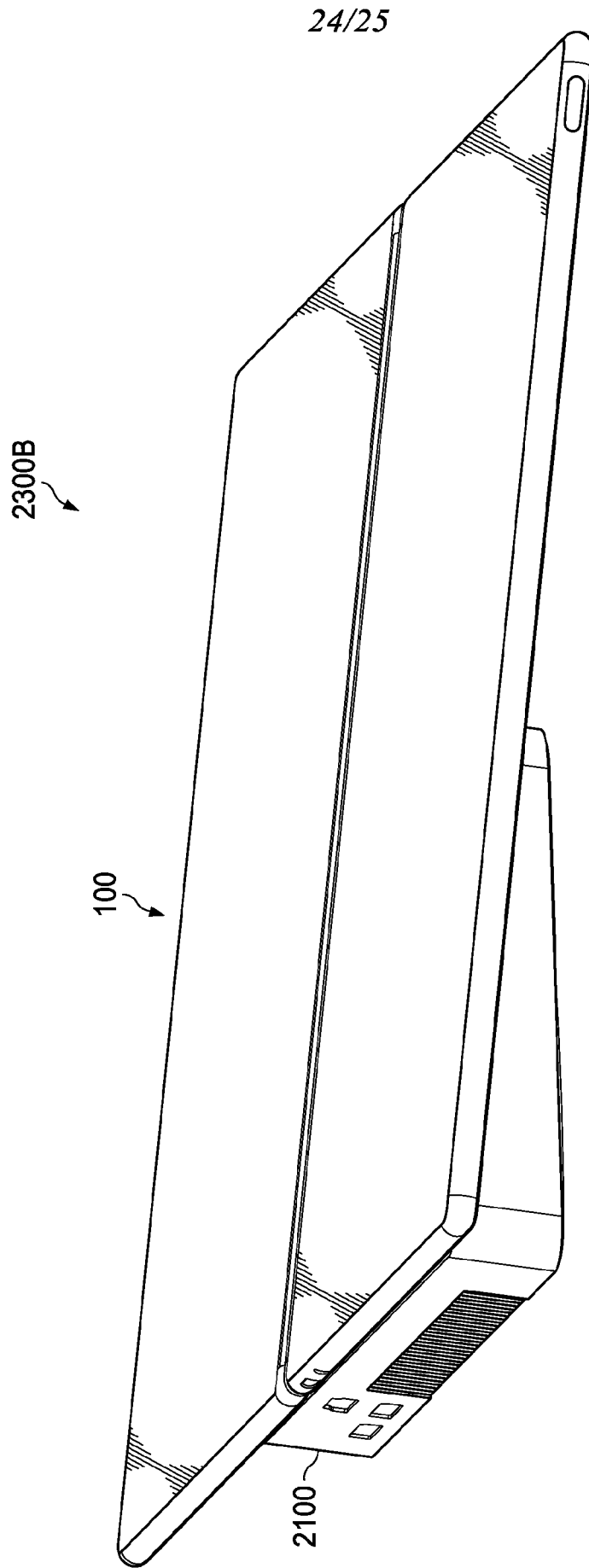

FIG. 23B

25/25

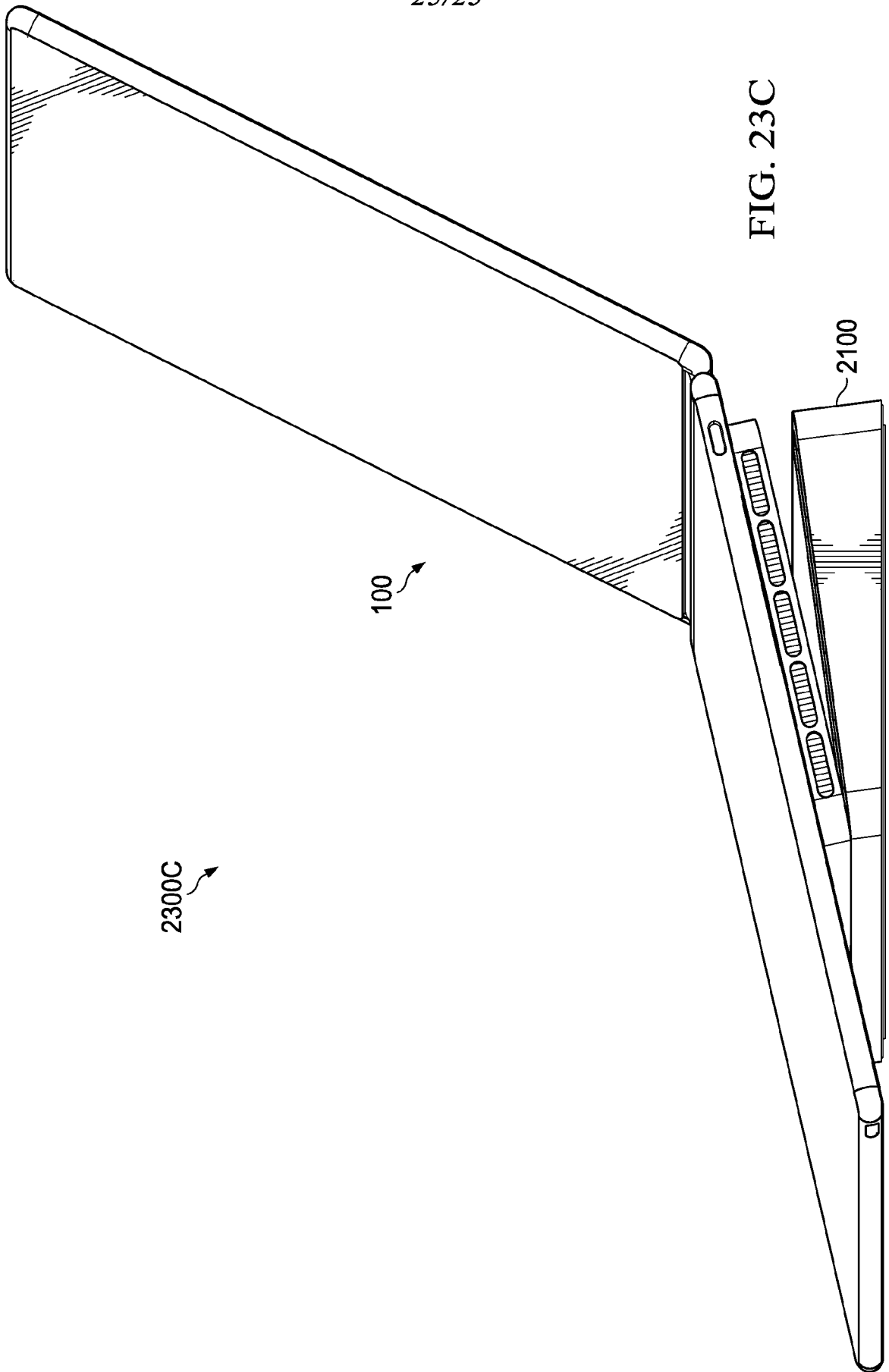

FIG. 23C

## INTERNATIONAL SEARCH REPORT

International application No.

PCT/US2019/060934

<b>A. CLASSIFICATION OF SUBJECT MATTER</b>		
IPC: G06F 1/16 CPC: G06F 1/1632		
According to International Patent Classification (IPC) or to both national classification and IPC		
<b>B. FIELDS SEARCHED</b>		
Minimum documentation searched (classification system followed by classification symbols) CPC: G06F 1/1632; USPC: 361/679.41, 44		
Documentation searched other than minimum documentation to the extent that such documents are included in the fields searched		
Electronic data base consulted during the international search (name of data base and, where practicable, search terms used) EAST: US-PGPUB; USPAT; USOCR; FPRS; EPO; JPO; DERWENT; IBM_TDB; Search Terms: HINGE, LEG, ARM, ROTAT \$3, HING\$3, MAGNET\$3, PROCESSOR, cpu, stand, base, memory		
<b>C. DOCUMENTS CONSIDERED TO BE RELEVANT</b>		
Category*	Citation of document, with indication, where appropriate, of the relevant passages	Relevant to claim No.
X Y A	US 8,724,312 B2 (JONES ET AL.) 13 May 2014 (13.05.2014) , entire document, entire document, entire document .	1-3 4, 5, 7 10, 13-15 and 18 6, 8, 9, 11, 12, 16, 17, 19 and 20
Y A	US 9,680,253 B2 (MEHANDJIYSKY ET AL.) 13 June 2017 (13.06.2017) , entire document, entire document.	4, 5, 7, 15 and 18 6, 8, 9, 11, 12, 16, 17, 19 and 20
Y A	US 2003/0221876 A1 (DOCZY ET AL.) 04 December 2003 (04.12.2003) , entire document, entire document.	10 6, 8, 9, 11, 12, 16, 17, 19 and 20
<input checked="" type="checkbox"/> Further documents are listed in the continuation of Box C. <input type="checkbox"/> See patent family annex.		
* Special categories of cited documents: "A" document defining the general state of the art which is not considered to be of particular relevance "E" earlier application or patent but published on or after the international filing date "L" document which may throw doubts on priority claim(s) or which is cited to establish the publication date of another citation or other special reason (as specified) "O" document referring to an oral disclosure, use, exhibition or other means "P" document published prior to the international filing date but later than the priority date claimed		"T" later document published after the international filing date or priority date and not in conflict with the application but cited to understand the principle or theory underlying the invention "X" document of particular relevance; the claimed invention cannot be considered novel or cannot be considered to involve an inventive step when the document is taken alone "Y" document of particular relevance; the claimed invention cannot be considered to involve an inventive step when the document is combined with one or more other such documents, such combination being obvious to a person skilled in the art "&" document member of the same patent family
Date of the actual completion of the international search <b>11 December 2019 (11.12.2019)</b>		Date of mailing of the international search report <b>18 DEC 2019</b>
Name and mailing address of the ISA/US <b>COMMISSIONER FOR PATENTS MAIL STOP PCT, ATTN: ISA/US P.O. BOX 1450 ALEXANDRIA, VA 22313-1450, UNITED STATES OF AMERICA</b> Facsimile No. (571)273-8300		Authorized officer <b>HARRY C. KIM</b> Telephone No. 571-272-4300

## INTERNATIONAL SEARCH REPORT

International application No.

PCT/US2019/060934

C. DOCUMENTS CONSIDERED TO BE RELEVANT		
Category*	Citation of document, with indication, where appropriate, of the relevant passages	Relevant to claim No.
Y A	US 2011/0128216 A1 (RENEWICK) 02 June 2011 (02.06.2011), entire document, entire document.	7 and 13-15 6, 8, 9, 11, 12, 16, 17, 19 and 20
-----		