

Aug. 17, 1965

R. S. WOLOWICZ ET AL

3,201,025

DEBOWING CURVED SCORE IN CARTON END WALL

Filed May 11, 1964

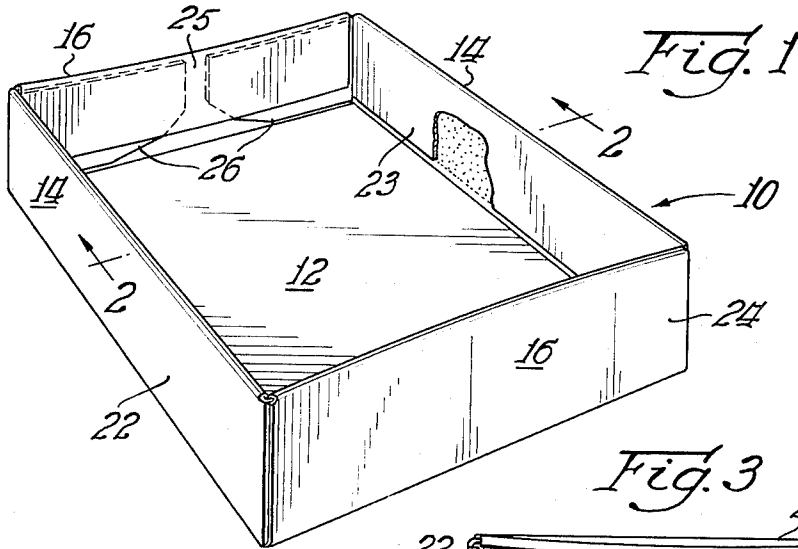

Fig. 1

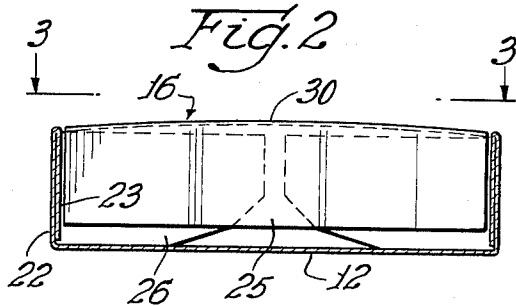

Fig. 2

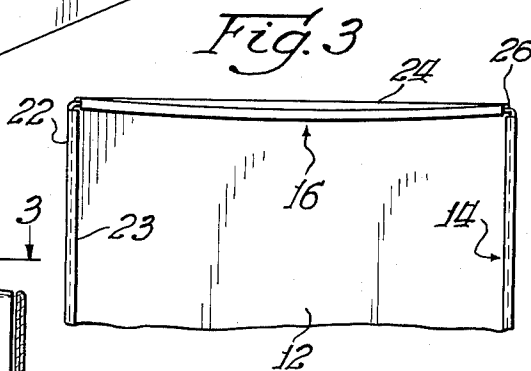

Fig. 3

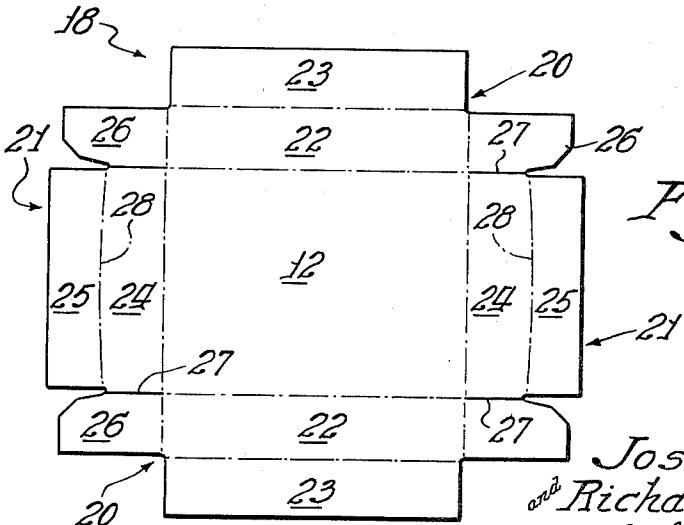

Fig. 4

Inventors:
Joseph A. Warner
and Richard S. Wolowicz
By: Richard W. Carpenter

1

2

3,201,025
**DEBOWING CURVED SCORE IN CARTON
 END WALL**

Richard S. Wolowicz, Chicago, and Joseph A. Warner, St. Charles, Ill., assignors to Container Corporation of America, Chicago, Ill., a corporation of Delaware
 Filed May 11, 1964, Ser. No. 357,279
 3 Claims. (Cl. 229—34)

This invention relates to cartons of the tray type having a bottom wall and a plurality of side walls hinged thereto and upstanding therefrom, and more particularly, to means for strengthening at least one of the side walls against transverse deflection or bowing outwardly of the carton.

In certain types of cartons, particularly open top trays having a bottom panel and a plurality of upstanding side walls, one or more of the side walls frequently is flexed transversely of its usual plane to distort the intended shape of the carton. This is caused before the carton is even folded by such factors as the grain direction of the blank and the natural resistance thereof to be folded as panels to specific angles relative to one another. Furthermore, many factors can flex the uprighted side wall, such as sterilizing the carton, if such is required, or of loading the carton. Also, in the open top tray, commonly a tubular sleeve fits snugly over the tray to slide axially along the length thereof to cover the tray. The sleeve is of similar overall length as the bottom panel or wall of the tray, so that if one end wall of the tray is bowed outwardly of the carton, its upper edge extends beyond the cover. Generally, distortion of the carton renders the carton unappealing in appearance, and further reduces its ability to support its contents properly or like cartons stacked on it.

This invention relates to an improvement in such cartons, wherein at least one of the upstanding walls is multi-ple and has panels interconnected along a hinge line spaced from the bottom panel and curved slightly convex in the direction therefrom. The curved hinge line causes the panels when folded face-to-face to bow slightly transversely from the usual plane of the wall inwardly of the carton to strengthen the wall against further transverse deflections. In addition, the curved convex edge extremity of the upstanding wall bows the overlying cover panel to strengthen it as compared to a flat panel.

Accordingly, an object of this invention is to provide for a carton an improved side wall construction having a bottom panel and a plurality of side wall panels hinged to and upstanding therefrom.

A more detailed object of this invention is to provide for a carton a side wall construction having panels hinged together on a curved hinge line operable when the panels are disposed in face-to-face relationship to bow the medial portions of the panels to a non-planar configuration convex toward the interior of the carton.

These and other objects will be more fully appreciated after reviewing the following specification, including as a part thereof the accompanying drawing, wherein:

FIG. 1 is a perspective view of an open top tray in which an embodiment of this invention is incorporated;

FIG. 2 is a sectional view taken generally from line 2—2 of FIG. 1;

FIG. 3 is a top plan view of the improved end wall shown in FIGS. 1 and 2; and

FIG. 4 is a plan view of the blank used to form the disclosed carton.

Referring more specifically to the details of construction, an open top tray 10 having a bottom wall 12 and opposed pairs of side walls 14 and end walls 16 hinged

to and upstanding from the bottom wall is shown in perspective in FIG. 1. The upstanding walls 14 and 16 generally are disposed normally to the bottom wall 12, and are connected to each other at their ends to form a continuous wall section about the perimeter of the bottom wall. A tube type sleeve (not shown) of interior open cross-dimensions similar to the end walls and of length approximately equal to the side walls commonly is disposed to slide over the tray to present a cover panel overlying the contiguous upper edge of the wall section.

Referring now to FIG. 4, the blank 18 from which the disclosed carton is formed is seen to include a central panel 12 and opposed endward panels 20 and 21 for forming the side and end walls, respectively. Each endward panel includes a medial panel and an end panel, represented as medial panel 22 and end panel 23 for the side walls, and as medial panel 24 and end panel 25 for the end walls. Each medial panel is hinged at one of its edges to an edge of the bottom panel 12, and is hinged at its opposite edge to the depending end panel. In addition, the alternate endward panels 20 for the side walls each has a side panel 26 hinged to opposite side edges of the medial panel 22, being separate from the medial panel 24 at cut line 27.

The panels 22—25 are adapted to be folded to and be secured in generally face-to-face relationship as inner and outer tray panels, and to be folded to substantially right angles to the central panel in the set-up tray. The side panels 26 extend between the inner and outer panels of the adjacent end wall 16 (as shown in dotted lines in FIGS. 1 and 2) and are bonded thereto. As such, the upstanding walls 14 and 16 are contiguous to one another and interconnected.

This invention comprises forming the hinge line 28 between the medial and end panels of at least one of the end walls 16 curved convex in the direction away from the central or bottom wall panel 12. Upon folding the panels about the hinge line into face-to-face relationship, the common edge at the hinge line assumes a curved upwardly convex contour 30 (FIG. 2), and the medial upper edge portions of the panels bow inwardly of the carton (FIG. 3) from the usual plane of the end wall across the junctures thereof with the adjacent side walls.

The end wall bowing inwardly of the carton provides that its upper edge is beneath the overlying cover panel (not shown) and further provides that the end wall is confined substantially normal to the bottom wall panel. This improves the stacking capacities of the tray as compared to existing trays wherein the inherent outward bowing of the end walls causes the end walls to extend beyond the cover panel and further to incline at some larger angle than 90° relative to the bottom wall. The appearance of the disclosed tray is improved also, since the corners of the tray remain square and the interconnecting panels remain substantially smooth and taut. Furthermore, the convex upper edge 30 is the greatest vertical distance from the bottom panel at the intermediate portion of the end wall (FIG. 2) between the adjacent side walls to provide a tighter fit with the tubular sleeve (not shown) positioned over the tray. The cover panel of the sleeve becomes curved or crowned to improve both its strength and appearance as compared to a planar panel.

The degree of curvature of the hinge line should be increased proportionately for increases in the depth of the carton.

While the subject invention has been disclosed on opposed end walls of a conventional four-sided tray, it will be understood that the improved wall construction can be used elsewhere also. Accordingly, it is understood that the invention is to be limited only by the language of the claims hereinafter following.

We claim:

1. A tray formed from a unitary blank of foldable paperboard cut and scored to form in combination:
 - (a) a bottom panel and a plurality of contiguous side walls hinged to and upstanding from the bottom panel;
 - (b) at least one of the side walls including inner and outer panels disposed in adjacent face-to-face relationship;
 - (c) one of the panels of said one side wall being attached at its lower edge to the bottom panel and being foldably connected at its opposite edge on a hinge line to the other panel;
 - (d) the hinge line being curved slightly convex away from the bottom panel, and being spaced at its opposite ends substantially equal distances from the bottom panel;
 - (e) the inner and outer panels bowing slightly from the usual plane of the one wall to strengthen the wall against transverse deflection thereof.
2. A tray formed from a unitary blank of foldable paperboard cut and scored to form in combination:
 - (a) a generally rectangular bottom wall and opposed pairs of side and end walls attached to and upstanding from the bottom wall;
 - (b) each of the side walls including an outer panel hinged at its lower edge to the bottom wall and an inner panel hinged at its upper edge to an upper edge of the outer panel;
 - (c) each of the end walls including:
 - (i) an outer panel hinged at its lower edge to the bottom wall;
 - (ii) an inner panel hinged at its upper edge to an upper edge of the outer panel along a folded line;
 - (iii) a medial panel lying between and in generally face-to-face relationship with the inner and outer panels, and being integrally hinged to one of the panels of the adjacent side wall;
 - (d) the fold line being curved slightly convexly in the direction away from the bottom wall, and being spaced at its opposite ends substantially equal distances from the bottom wall;
 - (e) the inner and outer panels of each end wall bowing slightly from the usual plane of the end wall

between the junctures at its opposite ends with the adjacent contiguous side walls.

3. A blank of foldable paperboard for forming a non-bowable side wall in a tray, comprising the combination of:
 - (a) a central panel and opposed pairs of endward panels hinged thereto along the outer perimeter thereof;
 - (b) one pair of opposed endward panels including:
 - (i) a medial panel attached at one of its edges to the central panel;
 - (ii) an end panel attached to the opposite edge of the medial panel;
 - (iii) opposing side panels integrally attached to the opposite side edges of the medial panel;
 - (c) the remaining opposed endward panels each including:
 - (i) a medial panel attached at one of its edges to the central panel;
 - (ii) an end panel attached hingedly along a given hinge line to the opposite edge of the last mentioned medial panel;
 - (d) the hinge line being curved slightly convex in the direction away from the central panel, and being spaced at its opposite ends substantially equal distances from the central panel;
 - (e) the medial and end panels being adapted to be folded face-to-face and to substantially right angles to the central panel, and the side panels to extend between the medial and end panels of the adjacent endward panels, whereat the panels attached together along the curved hinge line bow slightly from the usual plane of the wall between the junctures thereof with the adjacent upright walls of the set-up tray.

References Cited by the Examiner

UNITED STATES PATENTS

458,233	8/91	King	229—30
1,898,962	2/33	Hvistendahl	206—41
2,334,425	11/43	Lowey.	
2,415,869	2/47	Coleman	229—37
3,062,429	11/62	Lieman et al.	229—34

JOSEPH R. LECLAIR, *Primary Examiner.*

FRANKLIN T. GARRETT, *Examiner.*