



- (51) International Patent Classification:
A61F 13/02 (2006.01) *A61F 13/00* (2006.01)
- (21) International Application Number:
PCT/EP2016/065947
- (22) International Filing Date:
6 July 2016 (06.07.2016)
- (25) Filing Language: English
- (26) Publication Language: English
- (30) Priority Data:
15177153.2 16 July 2015 (16.07.2015) EP
- (71) Applicant: CARAG AG [CH/CH]; Bahnhofstrasse 9,
6340 Baar (CH).
- (72) Inventor: INEICHEN, Markus; Alte Landstrasse 59,
8700 Küsnacht (CH).
- (74) Agent: TROESCH SCHEIDEGGER WERNER AG;
André Werner, Schwäntenmos 14, 8126 Zumikon (CH).
- (81) Designated States (unless otherwise indicated, for every
kind of national protection available): AE, AG, AL, AM,
AO, AT, AU, AZ, BA, BB, BG, BH, BN, BR, BW, BY,

BZ, CA, CH, CL, CN, CO, CR, CU, CZ, DE, DK, DM,
DO, DZ, EC, EE, EG, ES, FI, GB, GD, GE, GH, GM, GT,
HN, HR, HU, ID, IL, IN, IR, IS, JP, KE, KG, KN, KP, KR,
KZ, LA, LC, LK, LR, LS, LU, LY, MA, MD, ME, MG,
MK, MN, MW, MX, MY, MZ, NA, NG, NI, NO, NZ, OM,
PA, PE, PG, PH, PL, PT, QA, RO, RS, RU, RW, SA, SC,
SD, SE, SG, SK, SL, SM, ST, SV, SY, TH, TJ, TM, TN,
TR, TT, TZ, UA, UG, US, UZ, VC, VN, ZA, ZM, ZW.

- (84) Designated States (unless otherwise indicated, for every
kind of regional protection available): ARIPO (BW, GH,
GM, KE, LR, LS, MW, MZ, NA, RW, SD, SL, ST, SZ,
TZ, UG, ZM, ZW), Eurasian (AM, AZ, BY, KG, KZ, RU,
TJ, TM), European (AL, AT, BE, BG, CH, CY, CZ, DE,
DK, EE, ES, FI, FR, GB, GR, HR, HU, IE, IS, IT, LT, LU,
LV, MC, MK, MT, NL, NO, PL, PT, RO, RS, SE, SI, SK,
SM, TR), OAPI (BF, BJ, CF, CG, CI, CM, GA, GN, GQ,
GW, KM, ML, MR, NE, SN, TD, TG).

Declarations under Rule 4.17:

— of inventorship (Rule 4.17(iv))

Published:

— with international search report (Art. 21(3))

(54) Title: MULTIFUNCTIONAL WOUND TREATMENT DRESSING

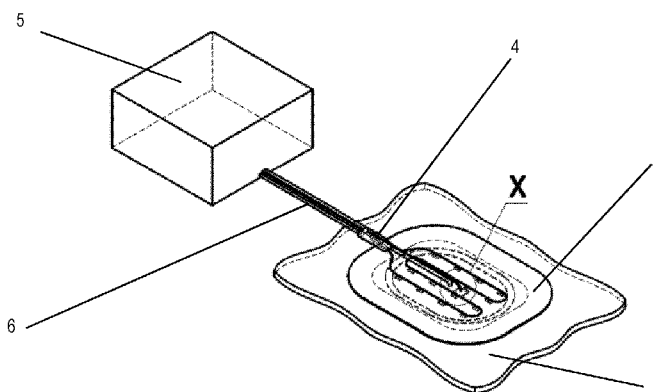

Fig. 2

(57) Abstract: The present invention relates to a multifunctional wound treatment dressing for administering a plurality of different therapeutic treatments to an open, chronic wound of a human or animal body. The proposed multifunctional wound treatment dressing comprises an occlusive wrapping (3) adapted for placing over a wound (2). The proposed multifunctional wound treatment dressing further comprises at least two of the group of electrical, optical or mechanical stimulation means adapted for transmitting electrical, optical or mechanical energy towards the wound to stimulate healing of the wound and/or means for applying a negative (i.e. sub-atmospheric) pressure to the wound (2). Thus, a variety of different healing stimulation treatments are possible performed together or in sequence by wearing the same occlusive wrapping (3) without the need of changing/removing temporarily the wrapping (3) for each change of treatment method.



MULTIFUNCTIONAL WOUND TREATMENT DRESSING

TECHNICAL FIELD

5

The present invention pertains to a means for treating open, chronic wounds. More specifically the present invention relates to a wound treatment dressing for administering therapeutic treatment to an open, chronic
10 wound of a human or animal body.

BACKGROUND OF THE INVENTION

Wound healing is impaired in some individuals, such as
15 patients suffering from certain disorders. This impairment in wound healing often leads to chronic wounds, the ongoing treatment of which represents a significant medical burden. Traditional approaches to the care and management of chronic non-healing wounds include passive techniques such
20 as applying antibiotics and protective wound dressings, e.g. comprising an agent such as silver to protect the wound against viral or bacterial penetration, relieving the wound of mechanical stresses, or the use of various techniques to remove wound exudate and necrotic tissue.
25 For the most part, these treatment approaches do not lead to a lasting recovery but merely prevent a further exacerbation and at best provide temporary relief.

Therefore, active approaches are employed to decrease the healing time and increase the healing success of chronic non-healing wounds. These active approaches are especially directed to appropriately altering the wound environment in order to enhance healing conditions. Such alterations may include the application of negative pressure, e.g. applying a sub-atmospheric pressure or a vacuum to the wound, using a sealing dressing and a vacuum pump. Negative pressure draws fluid out of a wound, which inhibits bacterial growth, and furthermore draws blood into the wound. Both of these effects promote healing. It has also been shown that specific types of electrical stimulation will alter the wound environment in a positive way so that a normal wound healing process can occur and in some cases be accelerated. Electrical stimulation for instance leads to increased tissue oxygen levels as well as blood flow at the application area and prevents the swelling of tissue adjacent to the wound. Moreover, phototherapy (i.e. light therapy or heliotherapy) is commonly applied as anti-bactericidal treatment, wound healing treatment, anti-fungal treatment, anti-parasitic treatment, anti-viral treatment, skin condition treatment, as well as to minimize scarring. However, at present there still exists a need for effective and efficient wound treatment dressings that provide an increased healing rate for a broad range of different poorly healing, i.e. chronic, open wounds.

SUMMARY OF THE INVENTION

It is therefore an object of the present invention to provide an improved wound treatment dressing capable of effectively and flexibly administering an appropriate
5 therapeutic treatment to a wide variety of open, chronic wounds of a human or animal body.

This object is achieved by the multifunctional wound
10 treatment dressing according to claim 1. Specific embodiments of the proposed wound treatment dressing are provided in the dependent claims 2 to 14.

The present invention provides a multifunctional wound
15 treatment dressing, comprising:
an occlusive wrapping adapted for placing over a wound on the surface of a skin, one side of the wrapping intended to face the wound and comprising a connector to be connected with an external apparatus box,
20 further comprising a combination of at least two of the following means:
- a negative pressure means, forming a substantially fluid-tight seal around the wound; and/or
- an electrical stimulation means, comprising at least one
25 electrode arranged at the wound treatment dressing and adapted for transmitting electrical energy towards the wound and/or

- 4 -

- an optical stimulation means, comprising an optical energy conducting and/or emitting element arranged at the wrapping and adapted for transmitting optical energy towards the wound; and/or
- 5 - a mechanical stimulation means, comprising a vibrational energy source, such as an ultrasound transducer, arranged at the wrapping and adapted for transmitting vibrational energy towards the wound; and/or
- means for removing wound exudates to an exterior of the
10 wrapping.

Providing a plurality of therapeutic means within a single wound treatment dressing allows to appropriately select and rapidly employ whichever therapy or combination of
15 therapies is most effective to treat and heal the specific open, chronic wound present. It especially allows to continuously apply a variety of different treatments or therapies to the wound without having to change the wound treatment dressing, which is typically a very tedious
20 process as well as often being painful for the patient.

In a further embodiment of the wound treatment dressing the wrapping is flexible or is rigid or is partly flexible and partly rigid.

25

In a further embodiment of the wound treatment dressing the wrapping is individually customized according to the

specific shape of a body part of an individual, at which
body part the wound is located. Thus, some specific shapes
may be provided for special body regions with specific
contours, e.g. more flat regions or more curved regions of
5 the body. A specific range of different sizes may be
provided too, to cover smaller or bigger wounds to be
treated. The wrapping may as an example be obtained by
means of a three-dimensional (3D) printing or additive
manufacturing process, in which successive layers of
10 material are laid down under computer control.

In a further embodiment the wound treatment dressing
further comprises a sensor for determining a state or
status of the wound, for instance for monitoring a variety
15 of parameters such as pH, temperature, tissue closure,
infection, biomarkers of healing, enzymes or moisture
level. By measuring or determining such parameters, the
stimulation process may be altered during the treatment
period to shorten the treatment time or to perform better
20 results.

In a further embodiment of the wound treatment dressing the
sensor comprises an optical sensor adapted for illuminating
the wound and collecting information regarding the wound
25 scattering parameters. For example, by observing the light
reflection of the wound, the absorption rate of the wound
or the skin may be derived for obtaining conclusions
regarding the progress of the healing process of the wound.

In a further embodiment the wound treatment dressing further comprises means for analyzing fluid exudate removed from the wound via the port, in particular for identifying progress of wound healing. In particular, the means for
5 analyzing the fluid exudate is adapted for determining one or more analytes indicative of one or more biochemical reactions that occur during wound recovery.

In a further embodiment the wound treatment dressing
10 further comprises a control unit adapted for adjusting a parameter in the wound treatment dressing and/or at the wound site, in particular dependent on data provided by the sensor.

15 In a further embodiment of the wound treatment dressing the electrical stimulation means is adapted for providing pulsed electrical stimulation, in particular is capable of delivering electrical pulses at a pre-selected or controllable pulse rate and intensity. In particular, the
20 electrical stimulation means is adjustable in response to changes in the determined state or status of the wound.

In a further embodiment of the wound treatment dressing the electrical stimulation means comprises an array of
25 electrodes, in particular the electrical stimulation means is adapted for creating at least one composite electrode from at least one of the electrodes in the array. In particular, the electrode composition of the at least one

composite electrode is adjustable in response to changes in the determined state or status of the wound. Thus, a very selective and specific wound treatment may be realized.

5 In a further embodiment of the wound treatment dressing the optical stimulation means is adapted to provide at least one of an infrared (IR), near-infrared (NIR), ultraviolet (UV, in particular UVB) emission towards the wound. The infrared emission especially being intended to influence a
10 temperature at the wound.

In a further embodiment of the wound treatment dressing the optical stimulation means is adapted for providing pulsed optical stimulation, in particular is capable of delivering
15 optical pulses at a pre-selected or controllable pulse rate and intensity. In particular, the optical energy conducting and/or emitting element is adapted for providing a selected light having substantially similar intensity across the wound site.

20

In a further embodiment, the optical energy emitting element comprises a plurality of emitting sources arranged at spaced locations along at least a portion of a periphery of the wound site.

25

In a further embodiment of the wound treatment dressing the optical energy conducting and/or emitting element comprises a light conducting substrate and at least one emitter

mounted to emit light into the substrate. In particular,
the optical energy emitting element comprises at least one
light emitting diode (LED). Furthermore, the optical energy
transmitting element may comprise at least one optical
5 fiber, the optical fiber for instance being split at one
end to form a plurality of sub-fibers.

In a further embodiment the wound treatment dressing
comprises an external apparatus box and a connection
10 arrangement, the connection arrangement being adapted to
receive one or more optical fibers and/or cables and/or
wires and/or suction tubes and being further adapted for
providing a connection to at least two of the following:

- 15 - a pumping means for generating a sub-atmospheric
pressure, e.g. a vacuum pump;
- an electrical power source;
- an optical source, such as an IR, NIR, UV (in particular
UVB) source;
- a control unit.

20

In this way a single arrangement can be employed to connect
the wound treatment dressing with (a variety of different)
external equipment such as a vacuum source for negative
pressure therapy, an electrical power source for electrical
25 stimulation therapy or a light source for phototherapy.
Moreover, the same arrangement can be utilized to transfer
measurement data obtained at the wound site from the wound

treatment dressing to an external therapy monitoring and control device.

BRIEF DESCRIPTION OF THE DRAWINGS

- 5 Figure 1 is a perspective view to a wound area on a skin, drafted in a pure schematic manner;
- Figure 2 is a perspective view of the wound treatment dressing according to the present invention applied to the wound area of Figure 1;
- 10 Figure 3 is a detail perspective view into the central area of the occlusive wrapping of Figure 2;
- Figure 4 is the bottom view onto the wound treatment dressing according to Figure 2;
- Figure 5 is a perspective view of an embodiment with
15 electrical stimulation means;
- Figure 6 is a perspective view of an alternative embodiment with electrical stimulation means;
- Figure 7 is a detail sectional view of a part of the occlusive wrapping of Figure 6;
- 20 Figure 8 is a perspective view of an embodiment for light treatment;
- Figure 9 is the bottom view of the embodiment of Figure 8;
- Figure 10 is a perspective view of another embodiment for light treatment with diffusive light; and
- 25 Figure 11 is a detailed sectional view of the embodiment of Figure 10.

DETAILED DESCRIPTION OF THE INVENTION

Figure 1 shows in a pure schematic manner the view onto a
5 wound area 2 on a skin 1. The wound may be an excavation or
an open cut in the skin of a person.

Figure 2 shows the upper view onto a wound treatment
dressing that is applied onto the wound area 2 onto skin 1.
An occlusive wrapping 3 is arranged over the area of the
10 wound. This wrapping 3 is incorporating at least two or
more stimulation means according to the present invention
and build up a sealed environment around the wound.

Thus, a modular wound treatment dressing is provided
composed of a basic wrapping 3 and an external apparatus
15 box 5. The same external apparatus box 5 may be used for
different types of wrappings 3, e.g. wrapping of different
shape for different locations of the wound such as arms,
elbows, knees or other peripheral locations and vice versa.

A pipe or tube 6 originating from the external apparatus
20 box 5 is preferably detachably connected via a connector 4
to the wrapping 3, as shown in Figure 2.

Preferably, the connector 4 is configured to have a plug-
socket for detachably receiving the pipe 6 of the external
apparatus box 5. Thus, the wrapping 3 can be placed at the
25 appropriate location on the body with the wound to be
treated without being disturbed by the pipe 6.

The external apparatus box 5 contains at least two of the
following devices:

- 11 -

- a pumping means for generating a sub-atmospheric pressure, e.g. a vacuum pump;
- an electrical power source;
- an optical source, such as an IR, NIR, UV (in particular
5 UVB) source;
- a control unit.

A suction tube 13 originating from pumping means (not shown) within the apparatus box 5 leads through the pipe 6 and the connector 4 into the occlusive wrapping 3. The end
10 of this tube 8 protrudes into the area of the lower surface of the wrapping 3, thereby facing the wound 2 to be treated by the wound treatment dressing. By applying a sub-atmospheric pressure, the occlusive wrapping 3 is creating a sub-atmospheric pressure or a vacuum around the wound 2.
15 The occlusive wrapping 3 is at the same time hold tight against the skin 1 around the wound 2, shielding the wound 2 to the outer atmosphere and protecting the wound area from outside influences.

In the example of Figure 2, the wrapping 3 comprises
20 furthermore the treatment part of an electrical stimulation means. An electrical wire 10 is arranged meandering within the wrapping 3 and has multiple junctions 11 arranged along its course to connect a treatment element 12 arranged in the lower surface of wrapping 3. The wire 10 is for example
25 connected to an electrical source arranged within the apparatus box 5 for transmitting electrical energy to the wound 2. In this example, multiple treatment elements 12

are arranged in a serial manner with respect to the electrical source.

Details of the arrangement of these components are more clearly shown in the detail view of section X in Figure 3.

5 A pressure sensor 9 is arranged at the lower surface of wrapping 3 to be close to the area of wound 2 and is connected via a cable 8 with a control unit arranged within the apparatus box 5. This sensor 9 provides data for
10 adjusting the parameters of the wound treatment controlled by a control unit within the apparatus box 5 that controls the action of the electrical source for transmitting appropriate electrical energy to the wound 2 adopted to the ongoing healing process.

Preferably, one or more such sensors 9 can be arranged
15 within wrapping 3 for determining the state or status of the wound 2, being connected to a respective analysis means arranged within the apparatus box 5. The sensors 5 may be adapted to monitor parameters such as pH, temperature, tissue closure, infection rate, biomarkers of healing,
20 enzymes or moisture level.

It is even possible to combine multiple sensors of different types to measure or determine different parameters that can be used for determining the state of
25 the wound healing process.

For the purpose of removing wound exudates, an additional suction tube may be arranged as well with its end protruding into the lower surface of wrapping 3 (not

shown). The exudates may be collected in a receptacle (not shown) arranged exchangeable within the apparatus box 5 for immediate or later analyzing purpose.

The control unit may be configured to power and control the different means arranged within the apparatus box 5. The control unit may be configured to simply switch on and off the different means or to control the behavior of those means in a predetermined or adjustable manner.

Figure 4 shows the bottom-view onto the wound-facing side of the wound treatment dressing, depicting the treatment elements 12, the opening of the suction tube 13 and one sensor 9 in the area of wrapping 3 facing the wound 2.

An alternative arrangement for a more individual control of the treatment elements 12 is shown in Figure 5. In this example, multiple electrical wires 15 are connected individually to each treatment element 12 at the lower surface of wrapping 3. Those treatment elements 12 may thus transmit individual and/or different electrical energy emerging from an electrical stimulation means arranged within the apparatus box 5 to the wound 2. The treatment elements 12 may be of the same type or even of different types, according to the needs of the wound treatment process.

Figure 6 shows in even more details a section through a part of the wrapping 3. The specific treatment element 12, arranged at the lower side of the wrapping 3, is connected with its related individual wire 10, by a junction 11 that leads from the upper surface, where the wires 10 are

arranged, through the wall of the wrapping 3 into the respective treatment element 12.

Figure 7 refers to an example with optical stimulation means for wound treatment, having multiple optical fibers 15 arranged at the upper side of the wrapping 3. Figure 8 shows the lower side of wrapping 3 with each fiber 15 leading into in a head 16 arranged at the lower side of wrapping 3 and directed to the wound 2. The heads 16 are emitting light directly through its opening onto the wound 2. Each of those light fibers 15 may be actuated individually, thereby enabling a localized light treatment of the wound, or may origin from one light fiber that is split into several sub-light fibers.

The light emitting source is located in an optical treatment stimulation means arranged in the apparatus box 5.

It is clear to the man skilled in the art that the light emitting means could be composed of light emitting diodes being arranged in the heads 16 and that are electrically connected to the apparatus box 5.

The light treatment may as well be performed by a diffuse light emitting disk 14, as shown in Figures 10 and 11. The diffuse light emitting disk 14 therefore is arranged at the lower surface of wrapping 3, thereby lying just ontop of the wound 2.

Furthermore, for a mechanical healing treatment of the wound 2, e.g. by sending ultrasound waves or vibrational energy toward the wound 2, respective elements can be arranged in the wrapping 3. Preferably, an ultrasound

transducer, controlled by a controller situated in the apparatus box 5, can be arranged as treatment element 12 in the lower surface of wrapping 3. Alternatively, a vibrational transmitter driven by an electromagnetic arrangement can be arranged in wrapping 3 for transmitting vibrational energy locally into the area of the wound 2.

It is an advantage of the inventive wound treatment dressing that it is composed of a basic apparatus box 5 and a configurable wrapping 3 comprising at least two of several wound healing stimulation means. Thus, an easy but economic production of wound treatment dressings for individual purposes is possible, using only few different parts to be composed together.

A further advantage is the possible combination of different healing stimulation treatments of a wound without the need of changing the wound treatment dressing when changing or altering the healing stimulation treatment. This leads to shorter treatment periods and less danger of infection.

LIST OF REFERENCE SYMBOLS

1	skin
2	wound
5	3 occlusive wrapping
4	connector
5	external apparatus box
6	connecting pipe
8	cable (for sensor)
10	9 sensor (pressure)
10	wire
11	junction (of wire)
12	treatment element
13	suction tube
15	14 light emitting disk (diffuse)
15	optical fiber
16	head of optical fiber

CLAIMS

1. A multifunctional wound treatment dressing (1),
comprising an occlusive wrapping (3) adapted for placing
5 over a wound (2) on the surface of a skin (1), one side of
the wrapping (3) intended to face the wound (2) and
comprising a connector (4) to be connected with an external
apparatus box,
further comprising a combination of at least two of the
10 following means:
- a negative pressure means, forming a substantially fluid-tight seal around the wound; and/or
 - an electrical stimulation means, comprising at least one
15 electrode (12) arranged at the wound treatment dressing
(1) and adapted for transmitting electrical energy
towards the wound (2) and/or
 - an optical stimulation means, comprising an optical
energy conducting and/or emitting element (16;14)
arranged at the wrapping (3) and adapted for
20 transmitting optical energy towards the wound (2);
and/or
 - a mechanical stimulation means, comprising a vibrational
energy source (12), such as an ultrasound transducer,
arranged at the wrapping (3) and adapted for
25 transmitting vibrational energy towards the wound (2);
and/or
 - a means for removing wound exudates to an exterior of
the wrapping (2).

2. A multifunctional wound treatment dressing according to claim 1, characterized in that the wrapping (3) is flexible or rigid or is partly flexible and partly rigid.

5

3. A multifunctional wound treatment dressing according to claim 1 or 2, characterized in that the wrapping (3) is individually customized according to the specific shape of a body part of an individual, at which body part the wound is located.

10

4. A multifunctional wound treatment dressing according to any one of claims 1 to 3, characterized in that it further comprises a sensor (9) for determining a state or status of the wound (2), for instance for monitoring a variety of parameters such as pH, temperature, tissue closure, infection, biomarkers of healing, enzymes or moisture level.

15

5. A multifunctional wound treatment dressing according to claim 4, characterized in that the sensor (9) comprises an optical sensor adapted for illuminating the wound (2) and collecting information regarding the wound scattering parameters.

20

25

6. A multifunctional wound treatment dressing according to any one of claims 1 to 5, characterized in that it

further comprises means for analyzing fluid exudate removed from the wound via a tube, in particular for identifying progress of wound healing, in particular adapted for determining one or more analytes indicative of one or more
5 biochemical reactions that occur during wound recovery.

7. A multifunctional wound treatment dressing according to any one of claims 1 to 6, characterized in that it further comprises a control unit adapted for adjusting
10 parameters in the wound treatment dressing and/or at the wound site, in particular dependent on data provided by the sensor.

8. A multifunctional wound treatment dressing according to any one of claims 1 to 7, characterized in that the
15 electrical stimulation means is adapted for providing pulsed electrical stimulation, in particular is capable of delivering electrical pulses at a pre-selected or controllable pulse rate and intensity, and in particular is
20 adjustable in response to changes in the determined state or status of the wound.

9. A multifunctional wound treatment dressing according to claim 8, characterized in that the electrical
25 stimulation means comprises an array of electrodes (12), in particular the electrical stimulation means is adapted for creating at least one composite electrode from at least one of the electrodes (12) in the array, wherein in particular

the electrode composition of the at least one composite electrode (12) is adjustable in response to changes in the determined state or status of the wound.

5 10. A multifunctional wound treatment dressing according to any one of claims 1 to 9, characterized in that the optical stimulation means is adapted to provide at least one of an infrared (IR), near-infrared (NIR), ultraviolet (UV, in particular UVB) emission towards the wound.

10

11. A multifunctional wound treatment dressing according to any one of claims 1 to 10, characterized in that the optical stimulation means is adapted for providing pulsed optical stimulation, in particular is capable of delivering
15 optical pulses at a pre-selected or controllable pulse rate and intensity.

12. A multifunctional wound treatment dressing according to any one of claims 1 to 11, characterized in that the
20 optical energy conducting and/or emitting element is adapted for providing a selected light having substantially similar intensity across the wound site, in particular comprises a light conducting substrate (14) and at least one emitter mounted to emit light into the substrate.

25

13. A multifunctional wound treatment dressing according to claim 12, characterized in that the optical energy emitting element comprises a plurality of emitting sources

(16) arranged at spaced locations along at least a portion of a periphery of the wound site, or comprises at least one light emitting diode (LED), or comprises at least one optical fiber (15), the optical fiber (15) for instance
5 being split at one end to form a plurality of sub-fibers.

14. A multifunctional wound treatment dressing according to any one of claims 1 to 13, characterized in that it comprises an external apparatus box (5) and a connection
10 arrangement (6), the connection arrangement (6) being adapted to receive one or more optical fibers (15) and/or cables (8) and/or wires (10) and/or suction tubes (13) and being further adapted for providing a connection to at least two of the following:

- 15 - a pumping means for generating a sub-atmospheric pressure, e.g. a vacuum pump;
- an electrical power source;
- an optical source, such as an IR, NIR, UV (in particular UVB) source;
- 20 - a control unit.

15. Method for a therapeutic wound treatment using a multifunctional wound treatment dressing according to one of claims 1 to 14 by forming a substantially fluid-tight
25 seal with an occlusive wrapping (2) around the wound and by combining of at least two of the following methods:

- 22 -

- applying a negative pressure around the wound (2) by the wrapping (2); and/or
- transmitting electrical energy towards the wound (2) from the wrapping (2) and/or
- 5 - transmitting optical energy towards the wound (2) from the wrapping (2); and/or
- transmitting vibrational energy towards the wound (2) from the wrapping (2); and/or
- removing wound exudates to an exterior of the wrapping
- 10 (2).

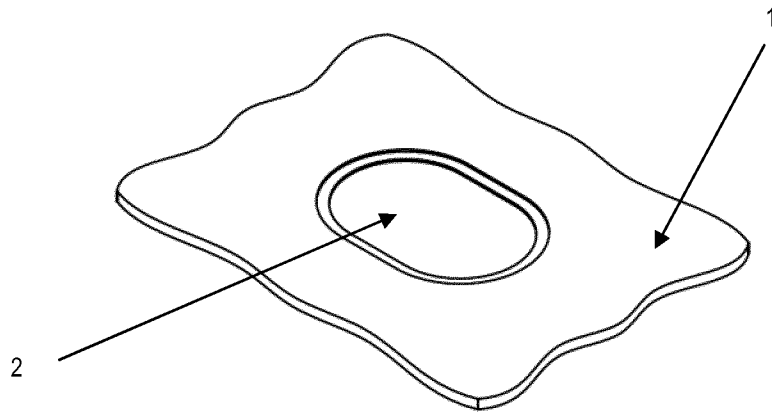

Fig. 1

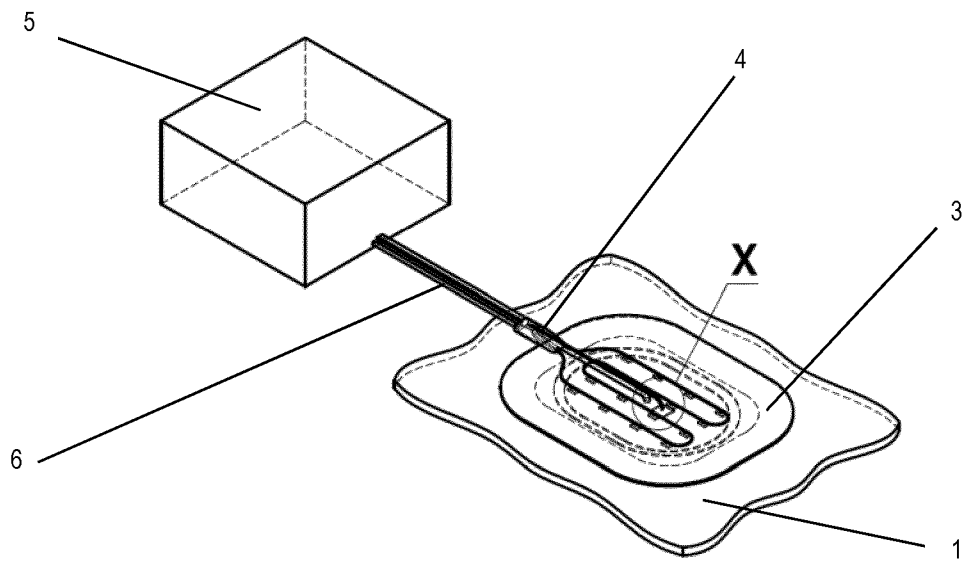

Fig. 2

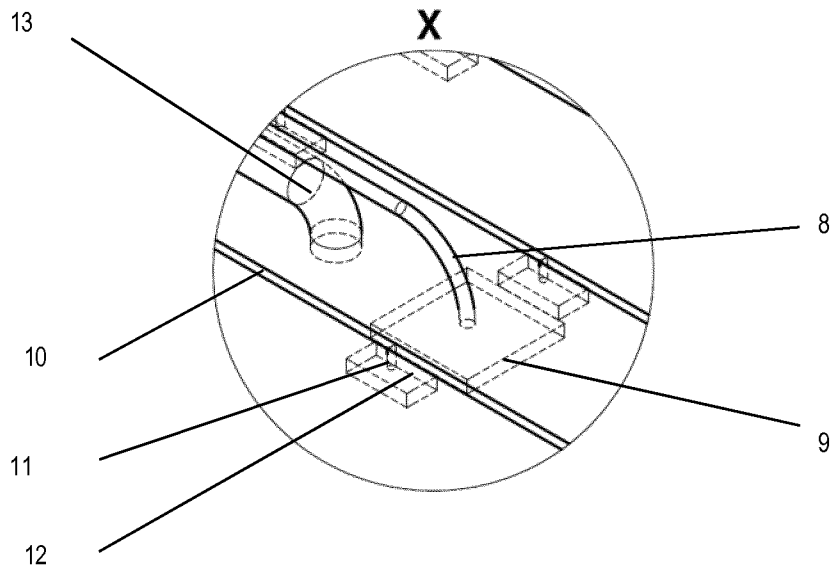

Fig. 3

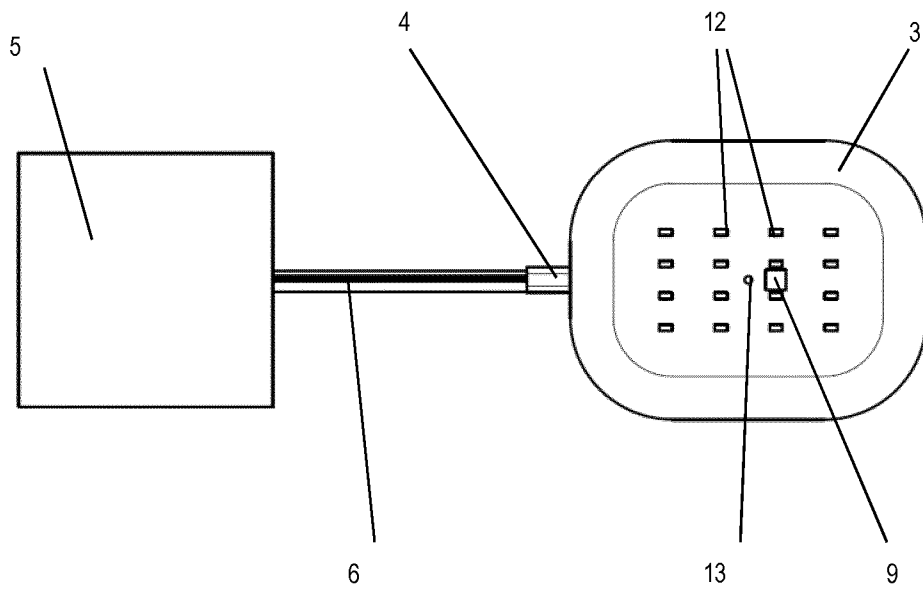

Fig. 4

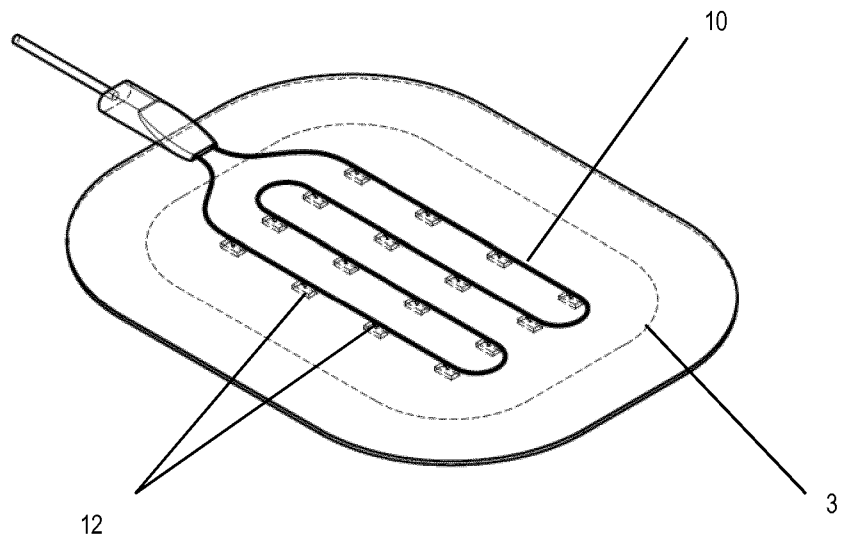

Fig. 5

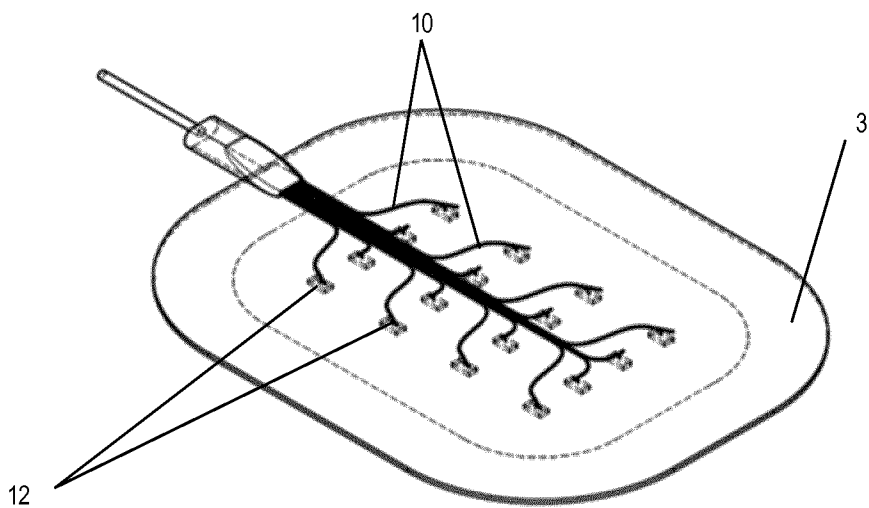

Fig. 6

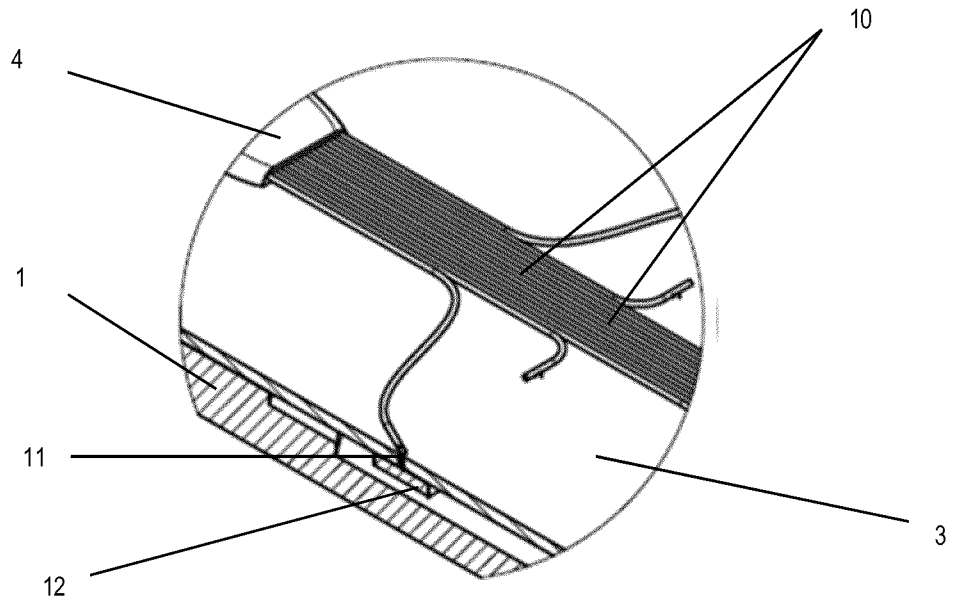

Fig. 7

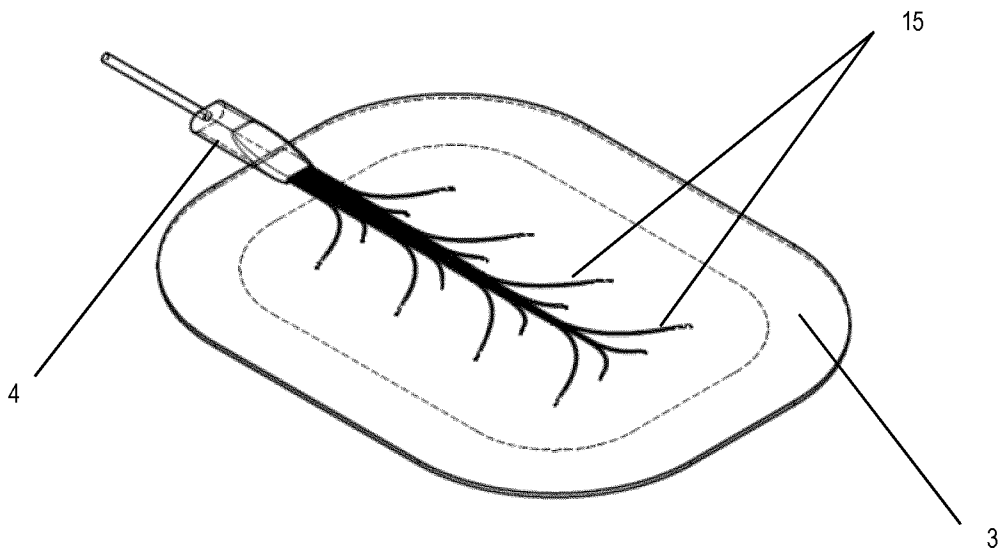

Fig. 8

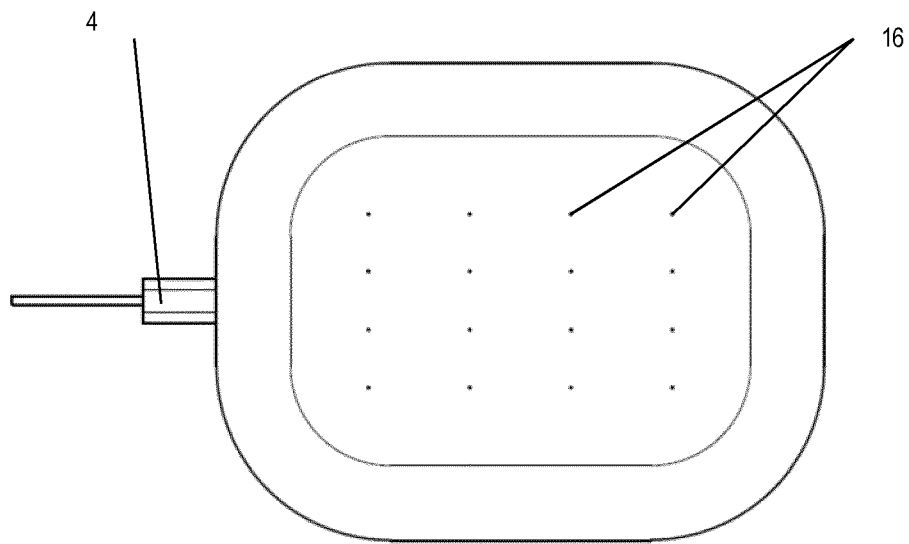

Fig. 9

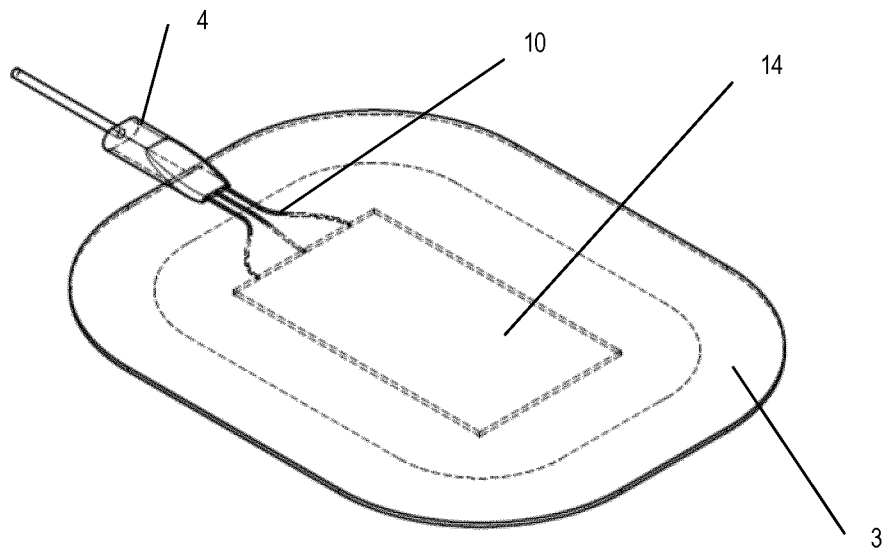

Fig. 10

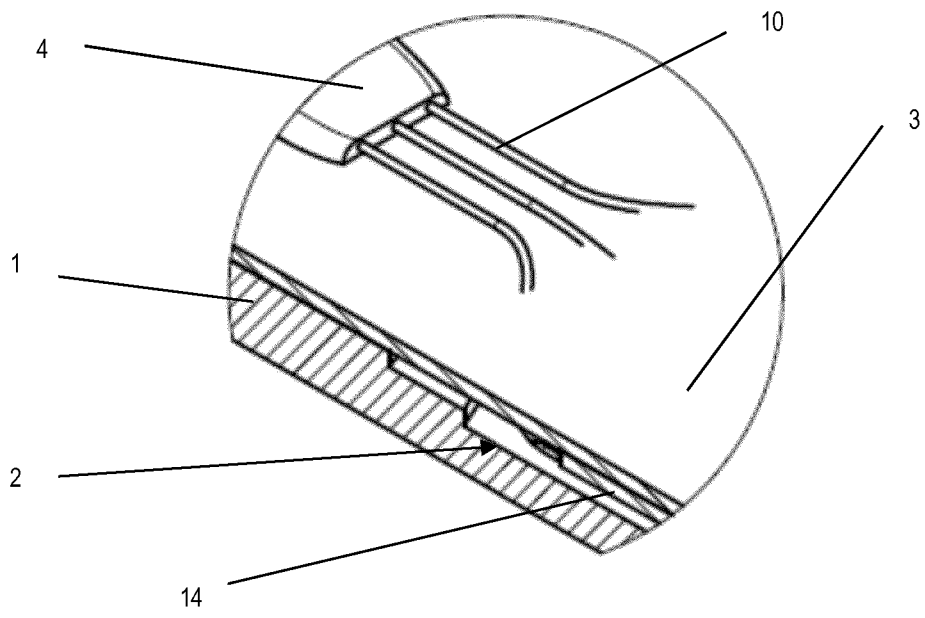

Fig. 11

INTERNATIONAL SEARCH REPORT

International application No.
PCT/EP2016/065947

Box No. II Observations where certain claims were found unsearchable (Continuation of item 2 of first sheet)

This international search report has not been established in respect of certain claims under Article 17(2)(a) for the following reasons:

1. Claims Nos.: 15
because they relate to subject matter not required to be searched by this Authority, namely:
Rule 39.1(iv) PCT - Method for treatment of the human or animal body by therapy
2. Claims Nos.:
because they relate to parts of the international application that do not comply with the prescribed requirements to such an extent that no meaningful international search can be carried out, specifically:
3. Claims Nos.:
because they are dependent claims and are not drafted in accordance with the second and third sentences of Rule 6.4(a).

Box No. III Observations where unity of invention is lacking (Continuation of item 3 of first sheet)

This International Searching Authority found multiple inventions in this international application, as follows:

1. As all required additional search fees were timely paid by the applicant, this international search report covers all searchable claims.
2. As all searchable claims could be searched without effort justifying an additional fees, this Authority did not invite payment of additional fees.
3. As only some of the required additional search fees were timely paid by the applicant, this international search report covers only those claims for which fees were paid, specifically claims Nos.:
4. No required additional search fees were timely paid by the applicant. Consequently, this international search report is restricted to the invention first mentioned in the claims; it is covered by claims Nos.:

Remark on Protest

- The additional search fees were accompanied by the applicant's protest and, where applicable, the payment of a protest fee.
- The additional search fees were accompanied by the applicant's protest but the applicable protest fee was not paid within the time limit specified in the invitation.
- No protest accompanied the payment of additional search fees.

INTERNATIONAL SEARCH REPORT

International application No
PCT/EP2016/065947

A. CLASSIFICATION OF SUBJECT MATTER
INV. A61F13/02 A61F13/00
ADD.
According to International Patent Classification (IPC) or to both national classification and IPC

B. FIELDS SEARCHED
Minimum documentation searched (classification system followed by classification symbols)
A61F

Documentation searched other than minimum documentation to the extent that such documents are included in the fields searched

Electronic data base consulted during the international search (name of data base and, where practicable, search terms used)
EPO-Internal, WPI Data

C. DOCUMENTS CONSIDERED TO BE RELEVANT

Category*	Citation of document, with indication, where appropriate, of the relevant passages	Relevant to claim No.
X	WO 2007/030599 A2 (TYCO HEALTHCARE [US]; PATEL HARISH A [US]; ACHESON DIANNE [US]) 15 March 2007 (2007-03-15)	1-4,6,7, 14
Y	figures 1-2 page 9, line 5 - page 11, line 19 page 15, line 19 - page 16, line 10 page 8, line 11 - line 12	8,9
X	US 2010/204752 A1 (TREMBLAY KATHLEEN [US]) 12 August 2010 (2010-08-12)	1-3,6,7, 14
Y	paragraphs [0018], [0021] - [0024]	8,9
	----- -/--	

Further documents are listed in the continuation of Box C.

See patent family annex.

* Special categories of cited documents :

"A" document defining the general state of the art which is not considered to be of particular relevance

"E" earlier application or patent but published on or after the international filing date

"L" document which may throw doubts on priority claim(s) or which is cited to establish the publication date of another citation or other special reason (as specified)

"O" document referring to an oral disclosure, use, exhibition or other means

"P" document published prior to the international filing date but later than the priority date claimed

"T" later document published after the international filing date or priority date and not in conflict with the application but cited to understand the principle or theory underlying the invention

"X" document of particular relevance; the claimed invention cannot be considered novel or cannot be considered to involve an inventive step when the document is taken alone

"Y" document of particular relevance; the claimed invention cannot be considered to involve an inventive step when the document is combined with one or more other such documents, such combination being obvious to a person skilled in the art

"&" document member of the same patent family

Date of the actual completion of the international search 12 October 2016	Date of mailing of the international search report 20/10/2016
--	--

Name and mailing address of the ISA/ European Patent Office, P.B. 5818 Patentlaan 2 NL - 2280 HV Rijswijk Tel. (+31-70) 340-2040, Fax: (+31-70) 340-3016	Authorized officer Mauhin, Viviane
--	---

INTERNATIONAL SEARCH REPORT

International application No
PCT/EP2016/065947

C(Continuation). DOCUMENTS CONSIDERED TO BE RELEVANT		
Category*	Citation of document, with indication, where appropriate, of the relevant passages	Relevant to claim No.
X	WO 2006/114638 A2 (SMITH & NEPHEW [GB]; BLOTT PATRICK LEWIS [GB]; HARTWELL EDWARD YERBURY) 2 November 2006 (2006-11-02)	1-3,6,7,14
Y	page 5, line 10 - line 25 page 7, line 10 - line 19 page 52, line 30 - page 53, line 19 page 54, line 12 - page 55, line 3 figures 1,3	8,9
X	----- WO 2010/093753 A1 (PERFUZIA MEDICAL INC [US]; BRINK-DANAN SAGI [US]; SCHUBERT SHAI Y [US]) 19 August 2010 (2010-08-19)	1-4,7,14
Y	paragraphs [0075] - [0076], [0081], [0083] - [0084], [0087] - [0088] paragraph [0039]	8,9
X	----- US 2009/177051 A1 (ARONS EDWARD M [US] ET AL) 9 July 2009 (2009-07-09)	1-7,10-14
Y	paragraphs [0024], [0029], [0031], [0033] - [0035], [0059], [0062] paragraphs [0055], [0071]	8,9
Y	----- WO 2014/188070 A1 (BO AKADEMI UNIVERSITY [FI]; TAMPEREEN TEKNILLINEN YLIOPISTO [FI]) 27 November 2014 (2014-11-27) the whole document	8,9

INTERNATIONAL SEARCH REPORT

Information on patent family members

International application No

PCT/EP2016/065947

Patent document cited in search report	Publication date	Patent family member(s)	Publication date	
WO 2007030599	A2	15-03-2007	AU 2006287461 A1	15-03-2007
			BR PI0616591 A2	28-06-2011
			CA 2620401 A1	15-03-2007
			CA 2923372 A1	15-03-2007
			CN 101257876 A	03-09-2008
			DK 1922044 T3	26-05-2015
			EP 1922044 A2	21-05-2008
			EP 2708216 A1	19-03-2014
			EP 2898908 A1	29-07-2015
			ES 2534895 T3	30-04-2015
			ES 2577105 T3	13-07-2016
			IL 189799 A	31-05-2016
			JP 2009509570 A	12-03-2009
			US 2007055209 A1	08-03-2007
			US 2010331797 A1	30-12-2010
US 2013331822 A1	12-12-2013			
WO 2007030599 A2	15-03-2007			

US 2010204752	A1	12-08-2010	US 2010204752 A1	12-08-2010
			US 2013172838 A1	04-07-2013

WO 2006114638	A2	02-11-2006	AU 2006238957 A1	02-11-2006
			CA 2606245 A1	02-11-2006
			CN 101208114 A	25-06-2008
			CN 104127920 A	05-11-2014
			EP 1874375 A2	09-01-2008
			JP 4964869 B2	04-07-2012
			JP 2008538960 A	13-11-2008
			KR 20070122545 A	31-12-2007
			US 2009306580 A1	10-12-2009
			US 2015335917 A1	26-11-2015
			WO 2006114638 A2	02-11-2006
ZA 200709198 B	25-03-2009			

WO 2010093753	A1	19-08-2010	CA 2752229 A1	19-08-2010
			EP 2395958 A1	21-12-2011
			JP 2012517324 A	02-08-2012
			JP 2015037595 A	26-02-2015
			US 2012059294 A1	08-03-2012
			WO 2010093753 A1	19-08-2010

US 2009177051	A1	09-07-2009	NONE	

WO 2014188070	A1	27-11-2014	EP 2999397 A1	30-03-2016
			US 2016101282 A1	14-04-2016
			WO 2014188070 A1	27-11-2014
