

A. I. SELCER.  
FOLDING HAT BOX.  
APPLICATION FILED JULY 12, 1912.

1,080,596.

Patented Dec. 9, 1913.

3 SHEETS-SHEET 1.

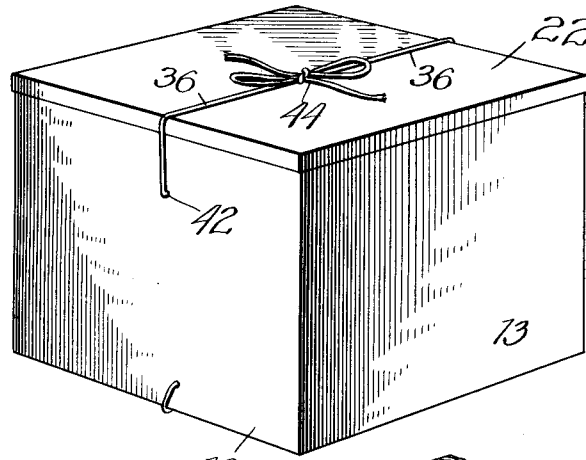

*Fig. 1.*

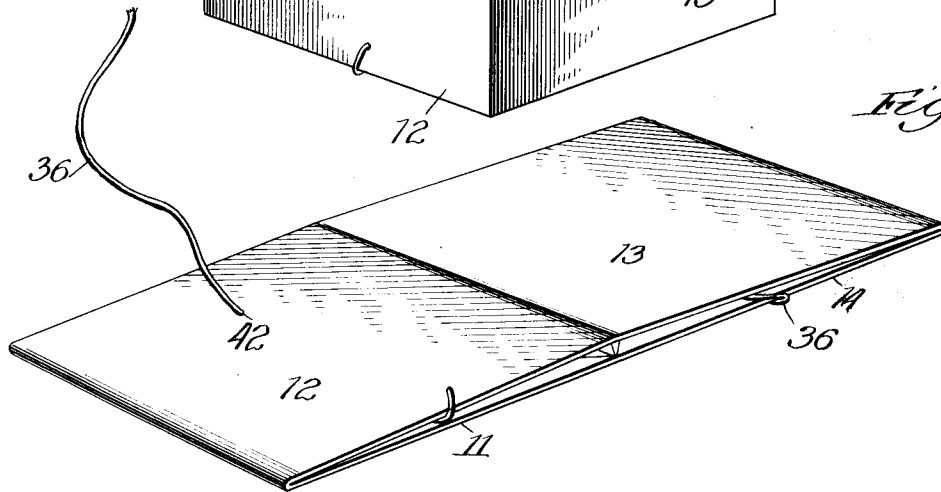

*Fig. 2.*

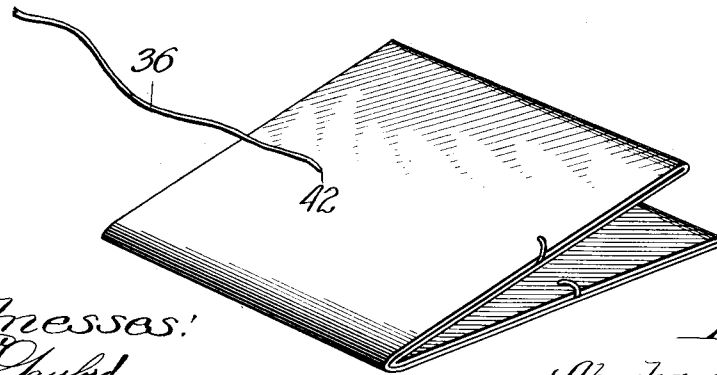

*Fig. 3.*

*Witnesses:*  
*G. J. Phylod.*  
*G. F. Chace.*

*Inventor:*  
*Abraham I. Selcer,*  
*By Cheever & Cox*  
*Attys.*

1,080,596.

Patented Dec. 9, 1913.

3 SHEETS—SHEET 2.

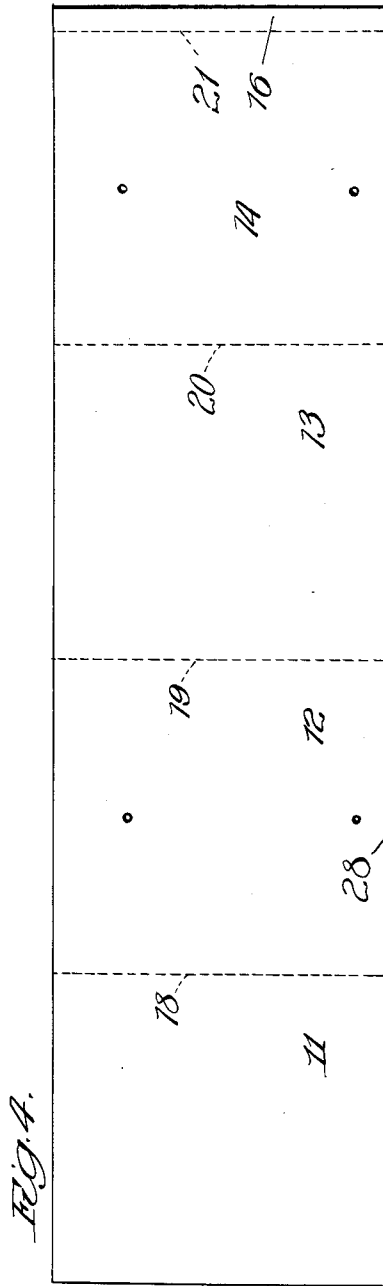

FIG. 4.

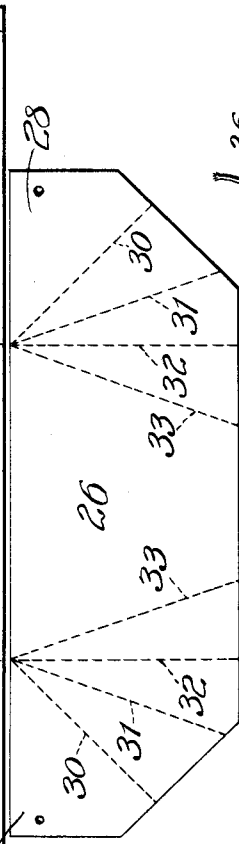

FIG. 5.

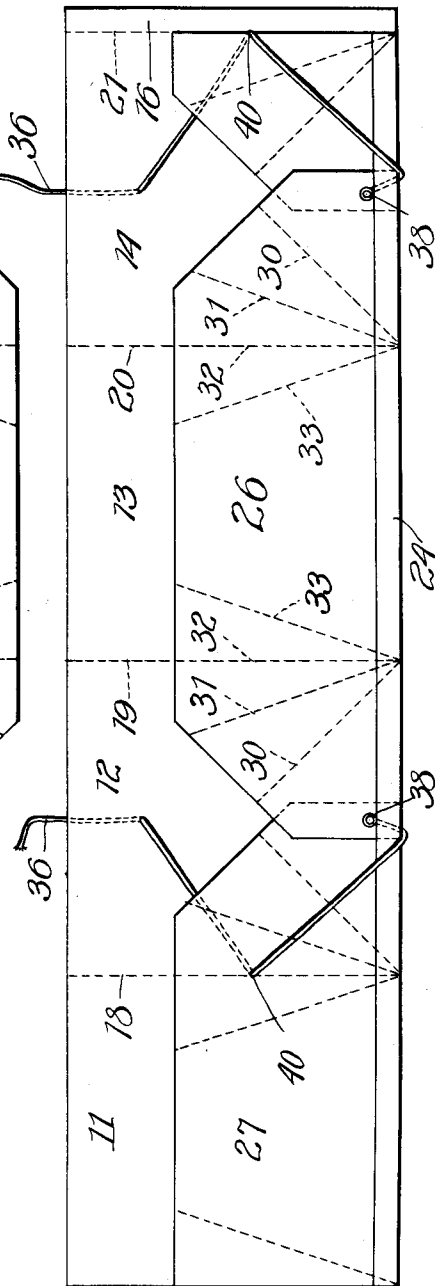

FIG. 6.

Witnesses:  
*[Signature]*  
 G. F. Chase.

21

Inventor:  
 Abraham I. Selcer,  
 By Cheever & Cox  
 Attys.

A. I. SELGER.  
 FOLDING HAT BOX.  
 APPLICATION FILED JULY 12, 1912.

1,080,596.

Patented Dec. 9, 1913.

3 SHEETS—SHEET 3.

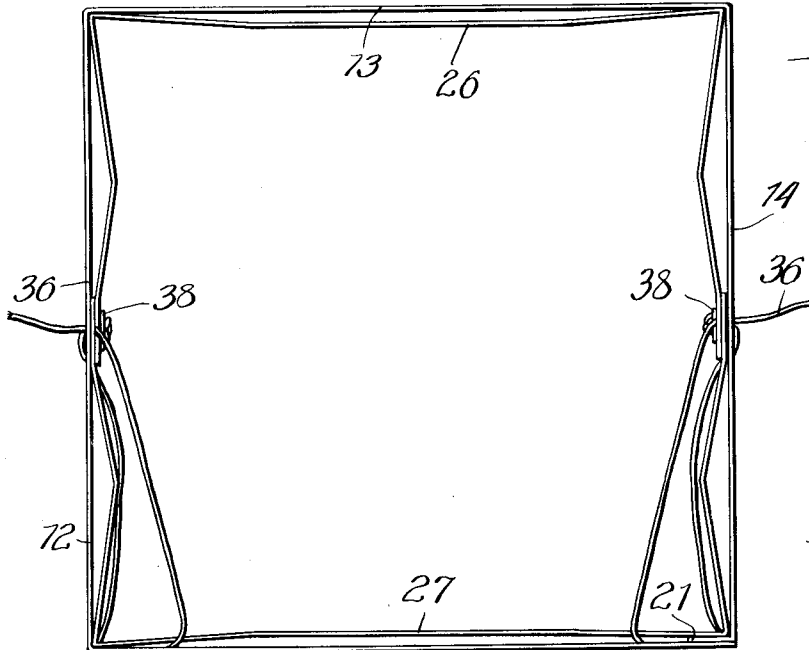

Fig. 7.

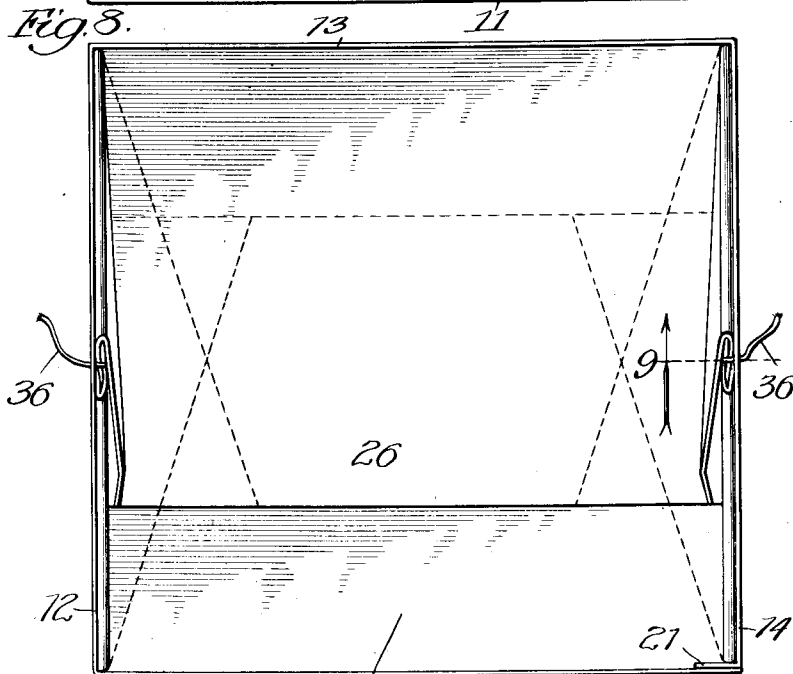

Fig. 8.

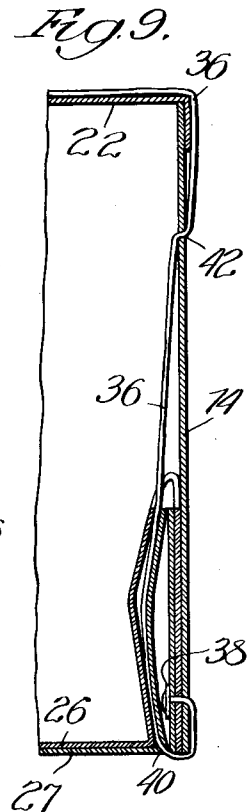

Fig. 9.

Witnesses: 27 11  
*E. B. Gaylord,*  
*A. F. Chase.*

Inventor:  
*Abraham I. Selger,*  
 By *Chever & Cox*  
*Attys.*

# UNITED STATES PATENT OFFICE.

ABRAHAM I. SELCER, OF CHICAGO, ILLINOIS, ASSIGNOR TO GAGE HAT WORKS, OF CHICAGO, ILLINOIS, A CORPORATION OF ILLINOIS.

## FOLDING HAT-BOX.

1,080,596.

Specification of Letters Patent.

Patented Dec. 9, 1913.

Application filed July 12, 1912. Serial No. 709,021.

### *To all whom it may concern:*

Be it known that I, ABRAHAM I. SELCER, a citizen of the United States, residing at Chicago, in the county of Cook and State of Illinois, have invented a certain new and useful Improvement in Folding Hat-Boxes, of which the following is a specification.

This invention relates to folding hat boxes, especially used by wholesale and retail dealers in ladies' hats.

The object of the invention is to provide a box which is, when ready for use, of sufficient size to contain a large hat and which will, on being folded, assume a very compact form for ready storage and shipment.

The invention consists in a novel form of box which can be easily and cheaply made and operated, which is satisfactory in operation and not readily liable to get out of order, which attains the foregoing objects.

The invention further consists in details of construction which will be more fully set forth in the specification and claim.

Figure 1 is a perspective view of a hat box illustrating this invention in its preferred form, said box being in what will be hereafter referred to as the normal or usable position. Fig. 2 illustrates the exterior of said box in partially folded position, and Fig. 3 shows it in substantially completely folded position. Fig. 4 illustrates the four side walls of the box developed or laid out flat. Fig. 5 shows one half of the member forming the bottom of the box and its connections to its adjacent side wall of the box separated from said side wall and flattened out. Fig. 6 is a developed view of the interior of the box showing all parts which are attached thereto in the position which they occupy in Fig. 7. Fig. 7 is a plan view looking into the box with the bottom members folded up into contact with the side walls in the position ready to be moved to the position of Fig. 2 and thence to that of Fig. 3. Fig. 8 is a corresponding view showing the interior of the box when the interior parts of Fig. 7 have been folded so that the box is in normal position ready for use. Fig. 9 is a sectional detail view on the line 9 of Fig. 8.

In order to clearly illustrate the various features of the structure the foldable parts shown in Figs. 7, 8, and 9, are somewhat enlarged and distorted from their natural positions.

The box is made rectangular, preferably, but not at all necessarily square, with four walls 11, 12, 13, and 14, the first and last being connected along the corner 21 by a pasted flap or splice 16, in the ordinary manner. These four walls may be formed from one piece of material scored in the lines 18, 19, and 20 to form the corners of the box, but the various walls may be separate and secured together by hinges, like flaps 16 without in any way departing from this invention. The box is closed by an ordinary cover 22. Whenever the horizontal and vertical dimensions of the largest sized wall of the box do not exceed the dimensions of this cover 22 the entire device, after being folded to the position of Fig. 3, may be placed in and packed within a cover 22, if desired. Merely for convenience, walls 11 and 13 will be referred to as "side walls" and walls 12 and 14 as "end walls".

Pivoted to each of the side walls 11 and 13 by means of a suitable hinge, such as the cloth edge 24, is a flap member 26, shown in developed form in Fig. 5, having end portions 28 preferably of a length greater than one-half the width of the adjacent end walls 12 and 14 secured to said respective walls 12 and 14 by that portion of the cloth hinge member 24 which is attached thereto. Similarly secured to end wall 11 is a corresponding flap 27. Each of these flaps is scored so as to be foldable along the lines 30, 31, 32, and 33. Lines 32 are perpendicular to the hinge edges of the flaps and in the positions of both Figs. 7 and 8, lie in substantially the planes of the respective adjacent end walls. Score lines 30 are located on the end portions of the flap 26 ninety degrees from lines 32. Score lines 31 are midway between lines 32 and 33 or twenty-two and one-half degrees from each wall. Score lines 33 are twenty-two and one-half degrees from lines 32, but toward the center of the flap 26. Each flap 26 is of a width greater than one-half the width of the end walls of the box which are adjacent to the side wall on which the flap is attached; that is to say, the width of flap 26 is greater than one-half the width of the adjacent end wall 12 or 14, this so that, as shown in Fig. 9, the flaps 26 upon the opposite side walls 11 and 13 will, when folded to the position of Fig. 8, overlap at the center, thus forming a proper bottom for the box. The result of

the construction just described is that when each flap 26 is folded from the position of Figs. 4 and 5 to the position of Fig. 6, and the portions of the end 28 of the flap which are outside of and beyond the score lines 30 are secured to the respective walls 12 and 14 by glue or the like, and then the wall 11 is attached to the wall 14 by the flap 16, the parts will all be in the position shown in Fig. 7, with the score or hinge line 30 making an angle of forty-five degrees with both the bottom edge and adjacent corner of the box. When, now, the operator takes hold of the respective opposite bottom flaps 26 and folds them from the position of Fig. 7. to that of Fig. 8, the flaps 26 form by overlapping each other in the manner described, a bottom for the box. This bottom is in and of itself quite rigid and self sustaining. In order, however, to make it even more satisfactory in this regard a pair of strings 36 are provided rigidly secured at the opposite end walls 12 and 14 of the box at the points 38, from which these strings thence extend outside of the side wall of the box down under the bottom of the side wall and thence loosely through the holes 40 in the adjacent bottom flap 27, thence up the inside of the box to the holes 42, thence to the outside of the box and thence over the cover 22, where they may be tied in the knot 44. Any strain placed upon this portion of the strings 36 which are, as just described, outside the box, is communicated to the bottom of the box, as a pull tending to draw the bottom folded flap 27 taut across the bot-

tom of the box opening and as this string construction thus reinforces the lower flap 27, the upper flap 26 is correspondingly supported because it rests upon flap 27.

Assuming that the box has been folded up, the person desiring to use the same rests it in the position of Fig. 3, then folds it to the position of Fig. 2, then opens it to the position of Fig. 7, then folds the flaps to the position of Fig. 8, then places the cover on the box, as shown in Fig. 1 and ties the knot 44. In folding up a used box the operation is reversed, passing successively through Figs. 1, 8, 7, 2, and 3.

The claims are:—

A collapsible box having side and end walls hinged together, a pair of oppositely disposed flaps hinged to the opposite side walls and adapted to form the bottom wall of the box, said flaps having hinged end portions secured by hinge connections to the inner surface of the end walls at an angle of substantially forty-five degrees with the plane of the bottom edge of said walls, whereby said flaps will be held against outward movement but free to be moved inwardly against the side walls to permit the box to be collapsed and folded, substantially as described.

In witness whereof, I have hereunto subscribed my name in the presence of two witnesses.

ABRAHAM I. SELCER.

Witnesses:

DWIGHT B. CHEEVER,  
BEN M. KOZENBLUC.