

H. S. LANSDELL.  
DAMPERS FOR ELEVATORS.

No. 192,517.

Patented June 26, 1877.

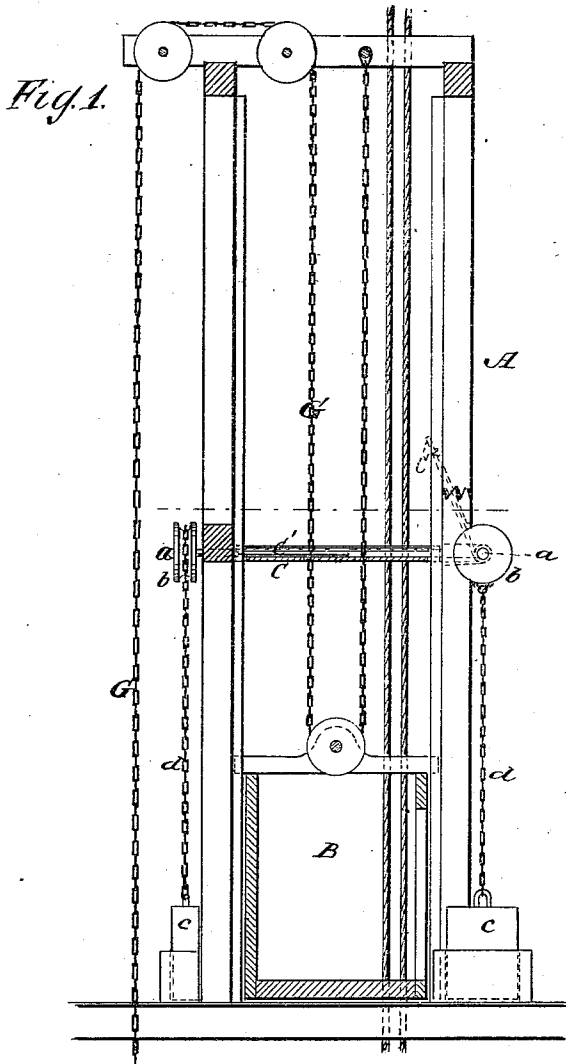

*Fig. 3.*



*Fig. 2.*

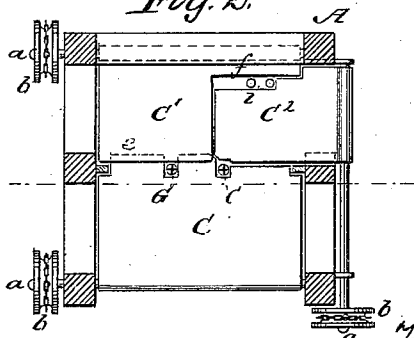

WITNESSES:

*E. Wolff.*  
*J. H. Scarborough.*

INVENTOR:

*H. S. Lansdell.*

BY

*Munn & Co.*

ATTORNEYS.

# UNITED STATES PATENT OFFICE.

HENRY S. LANSDELL, OF BROOKLYN, NEW YORK, ASSIGNOR TO HENRY LANSDELL AND JNO. S. LENG, OF SAME PLACE.

## IMPROVEMENT IN DAMPERS FOR ELEVATORS.

Specification forming part of Letters Patent No. 192,517, dated June 26, 1877; application filed May 21, 1877.

*To all whom it may concern:*

Be it known that I, HENRY S. LANSDELL, of Brooklyn, in the county of Kings and State of New York, have invented a new and Improved Damper for Elevators, of which the following is a specification:

This invention relates to dampers for elevators; and the nature of my invention consists in a sectional metallic or fire-proof damper, arranged at the landing of each story of an elevator shaft or passage, and so constructed and controlled by weights that it will automatically close and remain closed except during the ascent or descent of the box or cab, and will not interfere with the passage thereof, as will be hereinafter explained.

In the annexed drawings, Figure 1 is a vertical sectional view, showing one of my fire-proof dampers applied in an upright frame. Fig. 2 is a horizontal section taken in the plane indicated by dotted line *x x*. Fig. 3 shows one of the wheels from which a weight is hung.

Similar letters of reference indicate corresponding parts.

In the annexed drawings, the letter A designates an upright frame, composed of posts and guides, adapted for a box or cab, B. This cab is suspended by a rope or chain, G, and raised and lowered in the usual manner.

C C<sup>1</sup> C<sup>2</sup> designate three rectangular sections, which constitute my improved damper. These sections are made of sheet metal, and, when closed, as shown in Fig. 2, they will cut off communication between the upper and lower stories of a building, and thus prevent the passage of fire.

Each one of the sections is secured to a pivot-rod, *a*, bearing on one end a wheel, *b*, or its equivalent, from which a weight, *c*, is suspended by a chain, *d*. The weights operate to shut the sections after the ascent or descent of the cab B. This is effected by fastening

the chains to the wheels *b*, as shown in Fig. 3, thus enabling me to dispense with complicated contrivances, which would be liable to derangement.

The largest section C covers a little more than one-half of the passage-way, and is constructed with a lip, *e*, which extends past the adjacent edge of the section C<sup>1</sup>, and makes a close joint. A part of the section C<sup>1</sup> is cut away to receive the smallest section C<sup>2</sup>, which is also shaped to receive an extension, *f*, of the section C<sup>1</sup>, as shown in Fig. 2.

Between the edges of the sections C<sup>1</sup> C<sup>2</sup> the brake-ropes *i* pass, which will not interfere with them in the least, and which require only a small opening to be left through the damper.

I am aware that metallic hinged dampers have been used in connection with elevators for the same purpose as contemplated by me, and, therefore, I do not claim hinged dampers broadly. My object is mainly to provide for allowing the sections or leaves of the damper to be opened and shut freely by the cab, both in its ascent and descent, without interfering with the brake-ropes and suspension-ropes, or the passage-way or door of the cab.

It will be observed that when the cab is stopped to allow a person to enter or leave it, the section C<sup>1</sup> will lie to one side of the door.

Having thus described my invention, I claim as new and desire to secure by Letters Patent—

The hinged sections C C<sup>1</sup> C<sup>2</sup>, formed, as shown, in combination with weights *c*, suspended from wheels or arms *b* on pivot-rods *a*, substantially in the manner and for the purposes specified.

HENRY S. LANSDELL.

Witnesses:

C. SEDGWICK,  
ALEX. F. ROBERTS.