



- (51) International Patent Classification: Not classified
- (21) International Application Number: PCT/EP2013/053817
- (22) International Filing Date: 26 February 2013 (26.02.2013)
- (25) Filing Language: English
- (26) Publication Language: English
- (30) Priority Data:
 - BS2012A000027 27 February 2012 (27.02.2012) IT
 - BS2012U000008 27 February 2012 (27.02.2012) IT
 - BS2012U000009 29 February 2012 (29.02.2012) IT
 - MI2012A000553 5 April 2012 (05.04.2012) IT
- (71) Applicant: EOSFORO S.R.L. [IT/IT]; Via Provinciale, 50, I-25070 Pertica Alta (IT).
- (72) Inventor: BONOMINI, Pietro; Via San Carlo, 3, I-25087 Salo' (IT).
- (74) Agent: MODIANO, Micaela; Modiano & Partners, Via Meravigli, 16, I-20123 Milano (IT).
- (81) Designated States (unless otherwise indicated, for every kind of national protection available): AE, AG, AL, AM,

AO, AT, AU, AZ, BA, BB, BG, BH, BN, BR, BW, BY, BZ, CA, CH, CL, CN, CO, CR, CU, CZ, DE, DK, DM, DO, DZ, EC, EE, EG, ES, FI, GB, GD, GE, GH, GM, GT, HN, HR, HU, ID, IL, IN, IS, JP, KE, KG, KM, KN, KP, KR, KZ, LA, LC, LK, LR, LS, LT, LU, LY, MA, MD, ME, MG, MK, MN, MW, MX, MY, MZ, NA, NG, NI, NO, NZ, OM, PA, PE, PG, PH, PL, PT, QA, RO, RS, RU, RW, SC, SD, SE, SG, SK, SL, SM, ST, SV, SY, TH, TJ, TM, TN, TR, TT, TZ, UA, UG, US, UZ, VC, VN, ZA, ZM, ZW.

- (84) Designated States (unless otherwise indicated, for every kind of regional protection available): ARIPO (BW, GH, GM, KE, LR, LS, MW, MZ, NA, RW, SD, SL, SZ, TZ, UG, ZM, ZW), Eurasian (AM, AZ, BY, KG, KZ, RU, TJ, TM), European (AL, AT, BE, BG, CH, CY, CZ, DE, DK, EE, ES, FI, FR, GB, GR, HR, HU, IE, IS, IT, LT, LU, LV, MC, MK, MT, NL, NO, PL, PT, RO, RS, SE, SI, SK, SM, TR), OAPI (BF, BJ, CF, CG, CI, CM, GA, GN, GQ, GW, ML, MR, NE, SN, TD, TG).

Published:

— without international search report and to be republished upon receipt of that report (Rule 48.2(g))

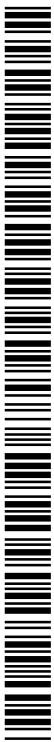

WO 2013/127791 A2

(54) Title: DEVICE FOR RECOVERING SOLAR ENERGY IN PHOTOVOLTAIC PLANTS

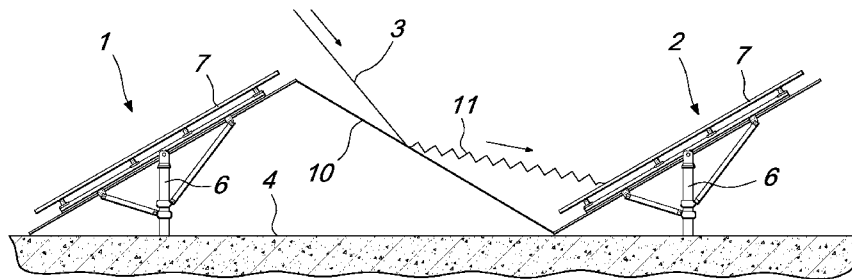

Fig. 2

(57) Abstract: A device for recovering solar energy in photovoltaic plants, its particularity residing in the fact that it comprises a reflective surface adapted to be connected between two adjacent rows of photovoltaic panels so as to occupy the free space between the two rows and capture the radiation that is incident between the two rows of photovoltaic panels and convey it onto one of the rows.

DEVICE FOR RECOVERING SOLAR ENERGY IN PHOTOVOLTAIC PLANTS

The present invention relates to a device for recovering solar energy in photovoltaic plants. More particularly, the invention relates to a device
5 for the reflection and refraction of external solar energy to photovoltaic generators of a photovoltaic plant.

As is known, alternative energies are a priceless resource from the point of view of energy and containment of noxious emissions into the atmosphere. In particular, the utilization of solar energy is a type of
10 alternative energy that is becoming widespread especially in countries where solar radiation is high throughout the year.

Currently existing photovoltaic plants generally have, as regards plants arranged on the ground, a plurality of rows of photovoltaic panels that are arranged with a preset or adjustable inclination with respect to the
15 incident solar radiation and so that their rows are mutually appropriately spaced.

Photovoltaic plants thus provided, despite being efficient from the point of view of the conversion of solar energy into electric power, are affected by the drawback that the solar radiation that is incident between
20 one row of panels and the directly adjacent row partly impinges the ground and is reflected without the directly adjacent row of photovoltaic panels being able to capture it.

Figure 1 illustrates the technical problem described above, the reference numeral 1 designating a row of photovoltaic panels and the
25 reference numeral 2 designating the directly adjacent row. The incident radiation 3 impinges the ground 4 and is reflected, 5, and cannot be captured at all by the photovoltaic panels 2.

This problem affects the efficiency of the photovoltaic panels, which could be improved if it were possible in some way to capture the incident
30 radiation that strikes the ground and is then reflected into space without the

possibility of being utilized.

On the other hand, existing photovoltaic panels, arranged in parallel rows, necessarily must maintain a minimum distance between the panels to avoid mutual shading.

5 The solar radiation that is incident on the surface between rows is partially absorbed and partially reflected and the reflectance index depends on the surface (typically grass, uncultivated soil or opaque surfaces).

In practice, this radiation is usually lost, both because the reflectance indexes are very low and because the reflection angle of the horizontal
10 surface is not optimum and much of the limited reflected energy is scattered toward the atmosphere and not toward the photovoltaic generators, as described earlier.

A photovoltaic plant is known from US 2011/100422 A1, which essentially consists of a plurality of longitudinal solar panels, a plurality of
15 longitudinal reflector sheets, and a plurality of bending-resistant clamping strips. The plurality of longitudinal reflector sheets are arranged between the rows of the solar panels. The reflector sheets are produced from a relatively bending-resistant sheets made of a metal or plates or films made from a plastic.

20 In the article "Analysis of the effects of outdoor and accelerated ageing on the optical properties of reflector materials for solar energy applications", lifetime tests on solar reflector materials are reported. Reflectors of silvered glass, anodised aluminium, thin film coated anodised aluminium and laquered rolled aluminium and laminated evaporated
25 aluminium were aged outdoors and in a climatical test chamber.

US 2010/000165 A1 describes a solar roof comprising one or more solar modules that are associated with a solar power plant, at least one reflective surface which is arranged at an angle to the solar module. The solar modules and the reflective areas comprise elements made from
30 transparent, partially transparent, and/or entirely reflective materials,

particularly in the form of a glass material.

EP 2 075 853 A2 relates to a photovoltaic system comprising photovoltaic modules (2a, 2b) which are inclined with respect to an installation surface for receiving sunlight and converting sunlight into
5 electric power by photoelectric effect. The photovoltaic system comprises reflective devices, namely mirrors, for increasing the solar energy that is incident on the modules.

US 4 316 448 A is related to a solar energy concentrator system with structures that allow adjustability of flexible sheet concentrators to achieve
10 solar radiation reflectability in accordance with seasonal posture of the sun. The solar energy concentrator system comprises a transparent thermoplastic base material of polyvinylidene fluoride comprising a thin film of aluminum, protected by a transparent coating of a protective material having high strength and good outdoor weathering properties, typically acrylic
15 compositions.

DE 10 2006 043635 A1 describes a system comprising one or more flat solar thermal elements, at least one planar photovoltaic panels and one or more reflectors.

The aim of the present invention is to provide a device for recovering
20 solar energy in photovoltaic plants that allows recovering much of the solar radiation that is incident on the surface between rows of the photovoltaic plant.

Within the scope of this aim, an object of the present invention is to provide a device for recovering solar energy in photovoltaic plants that does
25 not require specifically provided supporting structures for its operation.

Another object of the present invention is to provide a device for recovering solar energy in photovoltaic plants that allows increasing the production of electric power with respect to photovoltaic plants that do not have such a device.

30 Another object of the present invention is to provide a device for the

recovery of solar energy in photovoltaic panels that is highly reliable, relatively simple to provide and has competitive costs, and which can be easily mounted, adjusted and replaced.

This aim, as well as these and other objects that will become more
5 apparent hereinafter, are achieved by a device for recovering solar energy in photovoltaic plants, characterized in that it comprises a reflective surface consisting in a reflective sheet that is adapted to be connected between two adjacent rows of photovoltaic panels so as to occupy the free space between said two rows and capture the radiation that is incident between said two
10 rows of photovoltaic panels and convey it onto one of said rows.

Further characteristics and advantages of the invention will become more apparent from the description of preferred but not exclusive embodiments of the device according to the present invention, illustrated by way of non-limiting example in the accompanying drawings, wherein:

15 Figure 1 is a schematic lateral elevation view of a photovoltaic plant of a known type;

Figure 2 is a schematic lateral elevation view of a photovoltaic plant with the device according to the invention applied thereto;

20 Figure 3 is a schematic lateral elevation view of a photovoltaic plant with the device according to the invention;

Figure 4 is a schematic lateral elevation view of a photovoltaic plant with the device according to the invention applied in two distinct operating configurations;

25 Figure 5 is a schematic lateral elevation view of a photovoltaic plant with the device according to the invention applied according to a variation of Figure 4;

Figure 6 is a view of a further embodiment of the device according to the invention applied to a photovoltaic plant;

30 Figure 7 is a top plan view of a photovoltaic plant with the device according to the invention applied to two adjacent rows of photovoltaic

panels;

Figure 8 is a top plan view of a photovoltaic plant with the device according to the invention applied in a second operating configuration with respect to Figure 7;

5 Figure 9 is a schematic lateral elevation view of a photovoltaic plant with the device according to the invention according to a further constructive variation; and

Figure 10 is a view of a detail of the coupling system of the device according to the invention shown in Figure 9.

10 With reference to Figures 2 to 10, since Figure 1 has already been illustrated in the description of the background art, and wherein identical reference numerals correspond to identical elements, a photovoltaic plant, generally designated by the reference numeral 5, comprises a plurality of parallel rows of photovoltaic generators, in which two rows are shown for the sake of simplicity in description and are designated by the reference
15 numerals 1 and 2.

Each row of photovoltaic generators comprises a supporting structure 6 that supports a plurality of photovoltaic panels 7, which are appropriately inclined with respect to the incident radiation 3.

20 The device according to the invention comprises a surface made of reflective material 10, adapted to be arranged between two adjacent rows 1 and 2 of photovoltaic panels, so as to connect a panel supporting structure to the adjacent supporting structure, as shown for example in Figure 2.

The reflective surface 10 causes the incident radiation 3 that impinges
25 the surface 10, instead of being reflected into the atmosphere, to be reflected in the direction 11 on the photovoltaic panels 6 of the adjacent row 2.

In this manner, the radiation, which normally would be incident on the ground and would be reflected into the atmosphere, thus being lost, is instead reflected by the reflective surface and collected by the row of
30 adjacent photovoltaic panels.

Conveniently, the surface 10 has an adjustable angle, is not rigid, can be rolled up and is highly reflective.

The solar radiation 3 that is incident on the surface 10 is thus reflected instead of being absorbed. By way of example, the albedo effect of snow is created artificially, with the possibility of optimizing throughout the year the reflection of solar radiation according to the inclination of the reflective surface 10.

For example, the increase in the annual production of electric power, considering a reflective active index of the surface 10 equal to 0.75, is approximately 8.5% of total production. The increase is therefore visibly greater than what would be achieved by possibly arranging the reflective surface on the ground, since in this case the increase would stop at approximately 3-4%.

The device according to the invention does not require specific supporting structures, since it is anchored to the existing panel supporting structures 6 by means of arms made of metallic material. Preferably, the dimensions of the reflective surface 10 are such that air passes above and below through the adapted openings that facilitate both the ventilation and cooling of the photovoltaic generators and the elimination of rainwater.

Figure 3 is a view of the benefit provided by the device according to the invention, in addition to the one shown in Figure 2, due to the diffuse or albedo component that the reflective surface is able to provide simply by being present.

This effect is added to the one shown in Figure 2, which highlights the reflected component 11 that is independent of the reflective coefficient of the reflective surface 10, which up to a certain angle is total reflection.

Conveniently, the reflective surface 10 can be provided by a reflective sheet.

Figure 4 is a view of a possible embodiment of the device, in which the device provides for the reflective surface 10 to be anchored to the panel

supporting structure 6 by means of an arm 12 that is provided with a winding roller 13 on which the reflective surface can be rolled up.

In a downward region, steel grappels are anchored on the metallic arms 12 screwed to the panel supporting structure 6 in order to keep the reflective surface 10 under tension.

Said reflective surface can be coupled to the lower arm in various positions, thus varying its own inclination. The maximum or minimum inclination depends on the distance between rows and on the minimum height of the panels from the ground.

The example of Figure 4 illustrates two extreme positions: the maximum position, shown in broken lines, and the minimum position, shown in solid lines.

Figure 4 is a view of a particular type of lower anchoring arm 15, which assumes a particular shape so as to obviate any structural problems, discharging to the ground, by means of a foundation that can be deep or superficial on plinths, part of the stresses caused by the actions on the reflective sheet, particularly due for example to wind.

Therefore, in this embodiment the lower arm 15 is shaped so that it can be driven into the ground.

Figure 5 is a view of a configuration that is similar to the configuration of Figure 4, but with the lower arm, this time designated by the reference numeral 16, provided so that it is substantially similar to the upper arm 12 despite lacking the winding roller, which remains a prerogative of the upper arm 12.

Figure 6 is a view of a further constructive variation of the lower arm, designated in this case by the reference numeral 18, which can be used if, for technical, standards-related or administrative authorization reasons, the photovoltaic generators must be arranged very closely to the ground. In this case, the lower arm 18 is provided with a plate 19 that is anchored to the ground, if necessary, appropriately welded to the lower arm 18, which in

turn is connected to the panel supporting structure 6.

In this case, the reflective surface 10 can be anchored either directly to the lower arm 18 or to hooks 20 arranged at the plate 19.

Figure 7 is a plan view of the device according to the invention
5 arranged between the two rows of photovoltaic panels. The reflective surface 10 does not cover the entire surface between rows but leaves openings 22 to allow the passage of air and the flow of rainwater, as described earlier.

Figure 8 is a figure similar to Figure 7 but with the sheet or reflective
10 surface 10 arranged in a configuration of minimum inclination with respect to the ground, with the openings 22 that thus are reduced to the minimum possible size.

Figure 9 is a view of a further embodiment of the device according to
the invention, wherein the reflective surface or sheet 10 is provided with
15 slots both on the upper side and on the lower side, designated by the reference numeral 30, which slots are provided on the same central axis as the main beam 31 of the panel supporting structure 6.

The slots 30 of the reflective surface or sheet 10 are connected in an
upward region to the beam 31 by means of a tension element 32 made of
20 steel wire strand and a plate 33 made of steel and provided with end rings 34 that allow engagement in various positions, by means of a carabiner 35, of the tension element 32 and therefore of the corresponding reflective surface 10.

In a downward region it is possible to engage directly the slots of the
25 sheet with the hooks arranged on the lower arm or use metallic tension elements similar to the ones provided for the upper side. The position of the slots and the length of the tension elements are such that in an upward region and in a downward region passage of air is achieved through adapted openings that facilitate both ventilation and cooling of the photovoltaic
30 generators and the elimination of rainwater, as in the previous embodiment.

The engagement devices described earlier are perfectly symmetrical with respect to the reflective surface 10 and therefore the engagement devices are replicated both on the upper part and on the lower part of the panel supporting structure 6.

5 In practice it has been found that the device according to the present invention achieves fully the intended aim and objects, since it allows provision of a reflective surface that is arranged between adjacent rows of photovoltaic panels, capable of capturing the incident radiation that would be dispersed into the atmosphere and of conveying it onto the photovoltaic
10 panels of the directly subsequent row.

The device thus conceived is susceptible of numerous modifications and variations, all of which are within the scope of the accompanying claims.

For example, the system for coupling the sheets can comprise a guide
15 on the frame of the panel, for example at the plate 33, on which a slider can slide in which the sheet is engaged. The slider is adjustable in position so as to allow a variation of the inclination of the sheet without the need to disengage it.

The system for the sliding of the slider within the guide may
20 furthermore be of a motorized type, so that it can even automatically vary the inclination of the sheet, for example programming the inclination of the sheet according to preset data, such as the time of day and the period of the year, in relation to the position of the sun, or by connecting the motor drive to a conventional solar tracker.

25 The sheet may furthermore be provided so as to allow the passage of air and therefore reduce the forces caused by wind pressure and transmitted to the panel supporting structures.

Therefore, the sheet might be constituted by metallic strand wires in the longitudinal direction onto which deformable elements (plastic, metal or
30 others), fins, are fixed and arranged side by side so as to form the reflective

flat surface.

Under the pressure of the wind, the fins, which have a low stiffness, bend and allow the air flows to pass.

Finally, all the details may be replaced with other technically
5 equivalent elements.

In practice, the materials used, as well as the contingent shapes and dimensions, may be any according to the requirements and the state of the art.

The disclosures in Italian Patent Applications No. BS2012A000027,
10 BS2012U000008, BS2012U000009 and MI2012A000553 from which this application claims priority are incorporated herein by reference.

Where technical features mentioned in any claim are followed by reference signs, those reference signs have been included for the sole purpose of increasing the intelligibility of the claims and accordingly, such
15 reference signs do not have any limiting effect on the interpretation of each element identified by way of example by such reference signs.

CLAIMS

1. A device for recovering solar energy in photovoltaic plants (5), characterized in that it comprises a reflective surface (10) consisting in a reflective sheet that is adapted to be connected between two adjacent rows
5 (1, 2) of photovoltaic panels so as to occupy the free space between said two rows (1, 2) and capture the radiation (3) that is incident between said two rows of photovoltaic panels and convey it onto one of said rows (1, 2).

2. The device according to claim 1, characterized in that said reflective surface (10) is made of soft and flexible material.

10 3. The device according to claim 1, characterized in that said reflective surface (10) can be wound around a roller (13) that is arranged at an end of an arm (12) that is adapted to be connected to a photovoltaic panel supporting structure (6).

4. The device according to one or more of the preceding claims,
15 characterized in that said reflective surface (10) comprises a plurality of slots (30) adapted to be engaged by tension elements (32) for connection to said structures (6) for supporting said photovoltaic panels.

5. A photovoltaic plant, comprising a plurality of rows (1, 2) of photovoltaic panels supported by respective supporting structures (6), said
20 photovoltaic panels being arranged so as to be inclined with respect to the incident solar radiation (3), characterized in that it comprises a device according to one or more of the preceding claims.

6. The photovoltaic plant according to claim 5, characterized in that said supporting structures (6) are provided with an arm (12) that is provided
25 with a roller (13) for rolling up said reflective surface (10).

7. The photovoltaic plant according to claim 5, characterized in that said reflective surface (10) is connected to supporting structures (6) of photovoltaic panels that belong to adjacent rows (1, 2) by tension elements (32) that are adapted to be coupled to rings (34) provided at plates (33)
30 formed on the supporting structures (6) of said photovoltaic panels.

8. The photovoltaic plant according to one or more of claims 5 to 7, characterized in that said reflective surface (10) is coupled to an upper arm (12) of a supporting structure (6) and to a lower arm (16; 18) of an adjacent supporting structure (6).

5 9. The photovoltaic plant according to claim 8, characterized in that said lower arm (16) is shaped so that it can be driven into the ground.

10 10. The photovoltaic plant according to claim 8, characterized in that said lower arm (18) is welded to a plate (19), which is adapted to be fixed to the ground and is provided with hooks (20) for the engagement of said
10 reflective surface (10).

15 11. The photovoltaic plant according to one or more of claims 5 to 10, characterized in that said reflective surface (10) is anchored to said upper arm (12) and said lower arm (16; 18), leaving empty spaces (22) between said upper and lower arms and said reflective surface (10), proximate to said
15 upper and lower arms, for the passage of air and for draining rainwater.

12. The photovoltaic plant according to one or more of claims 5 to 11, characterized in that said reflective surface is constituted by metallic strand wires in a longitudinal direction onto which deformable elements are fixed which are arranged side by side so as to form the reflective flat surface.

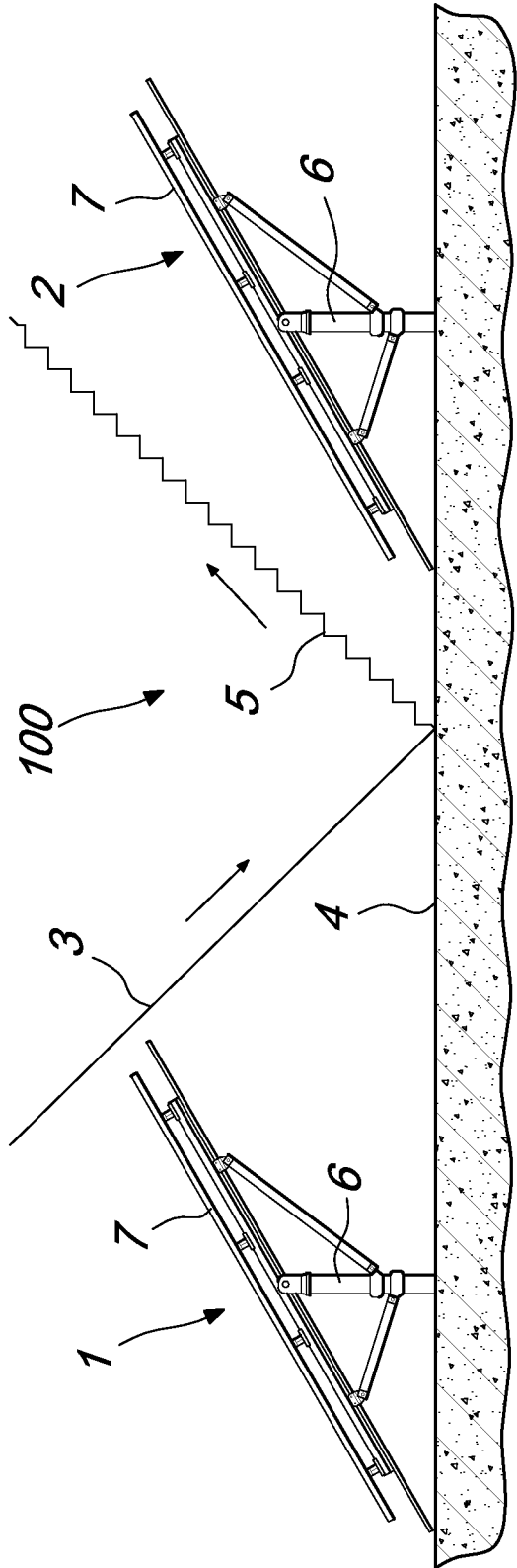

Fig. 1

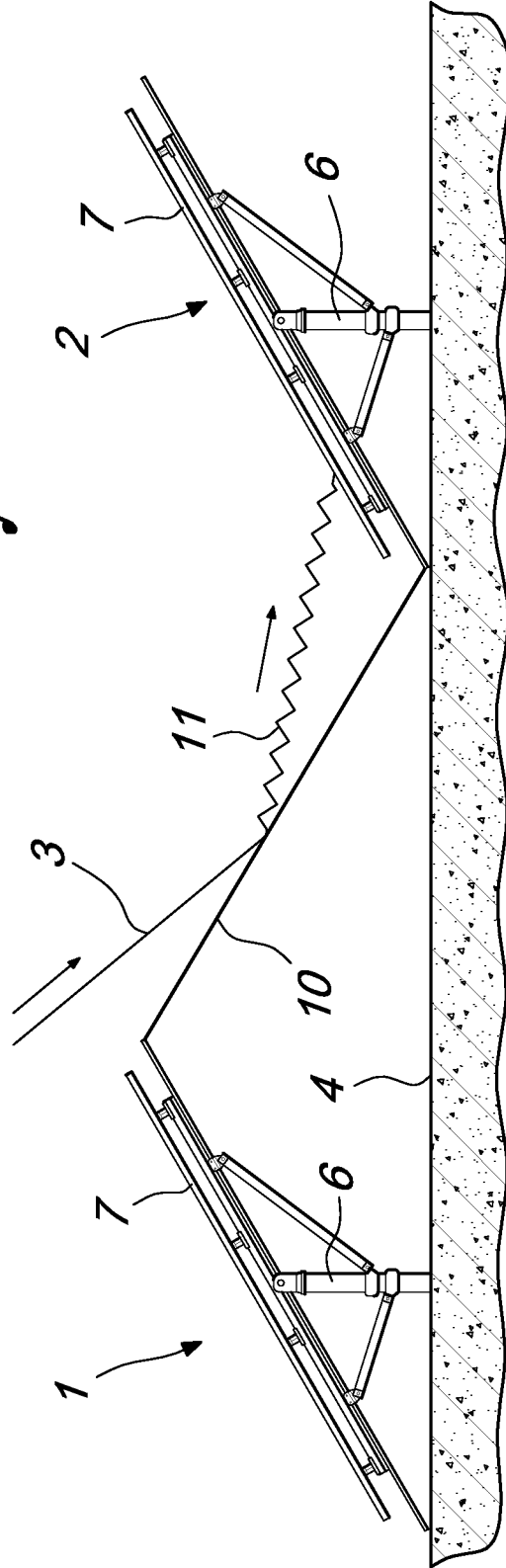
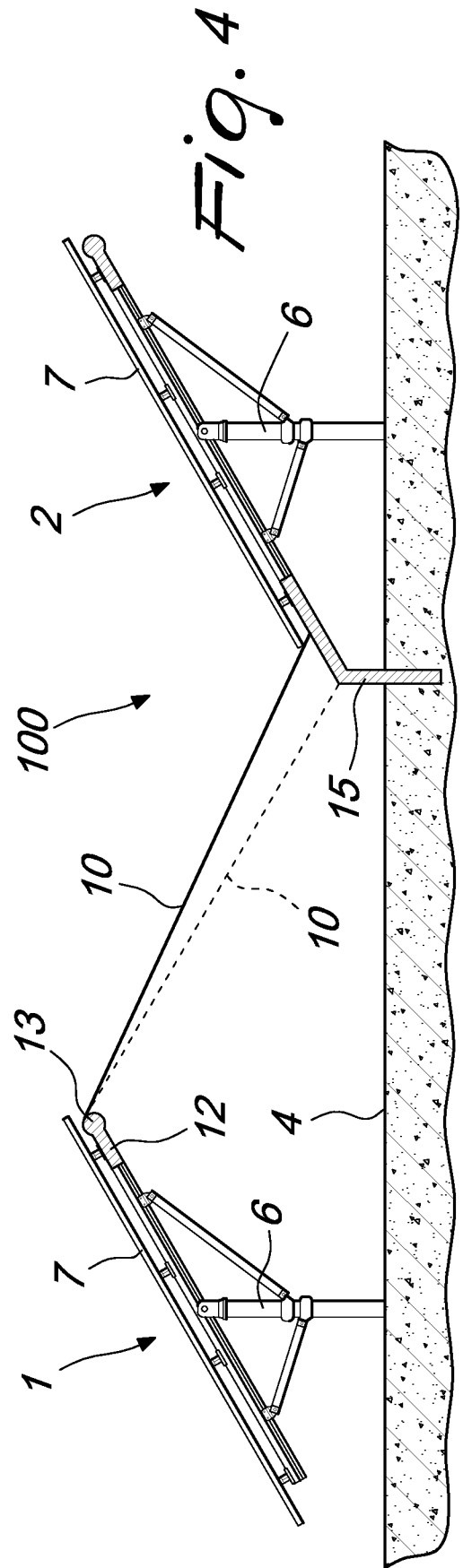
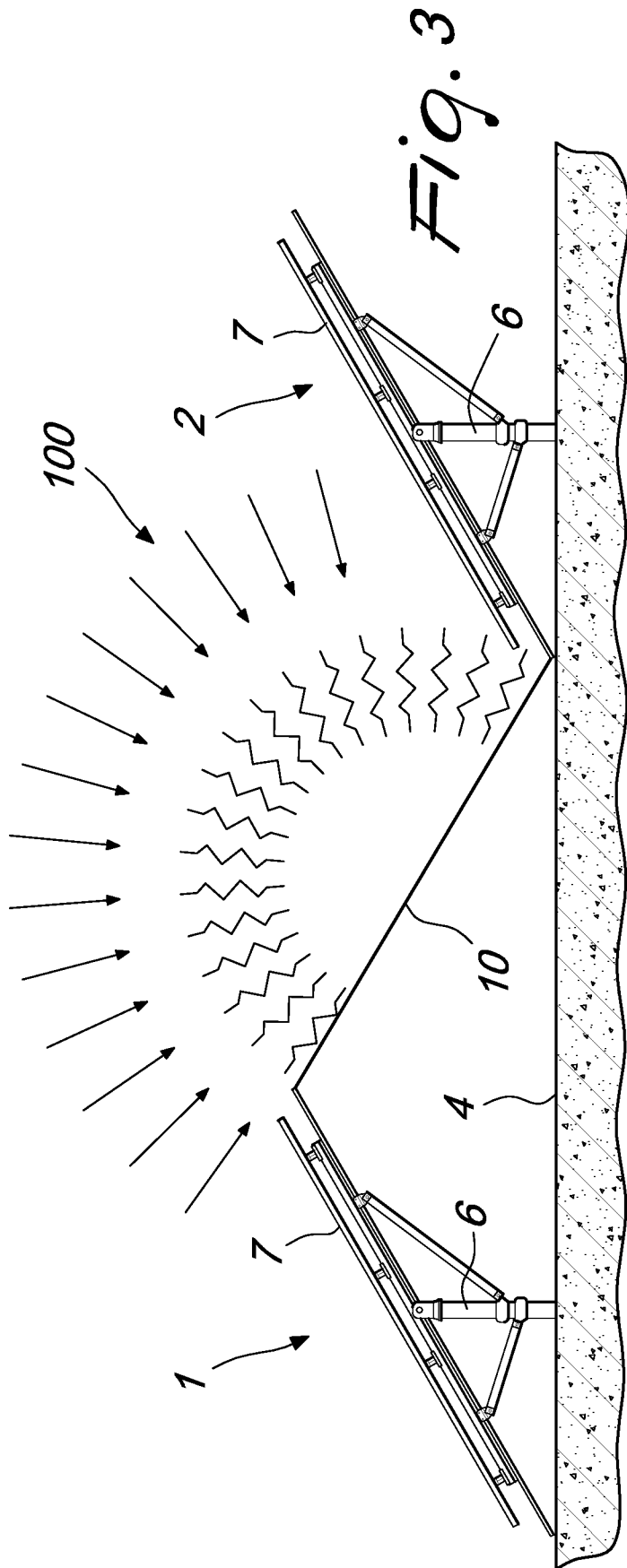

Fig. 2



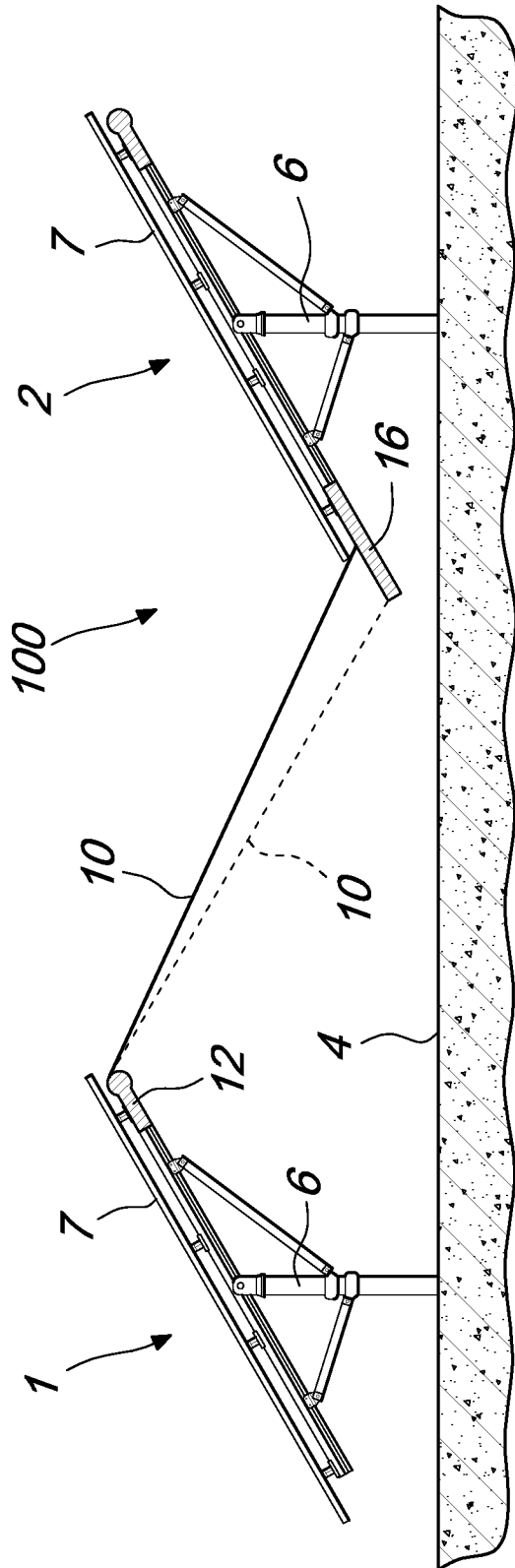

Fig. 5

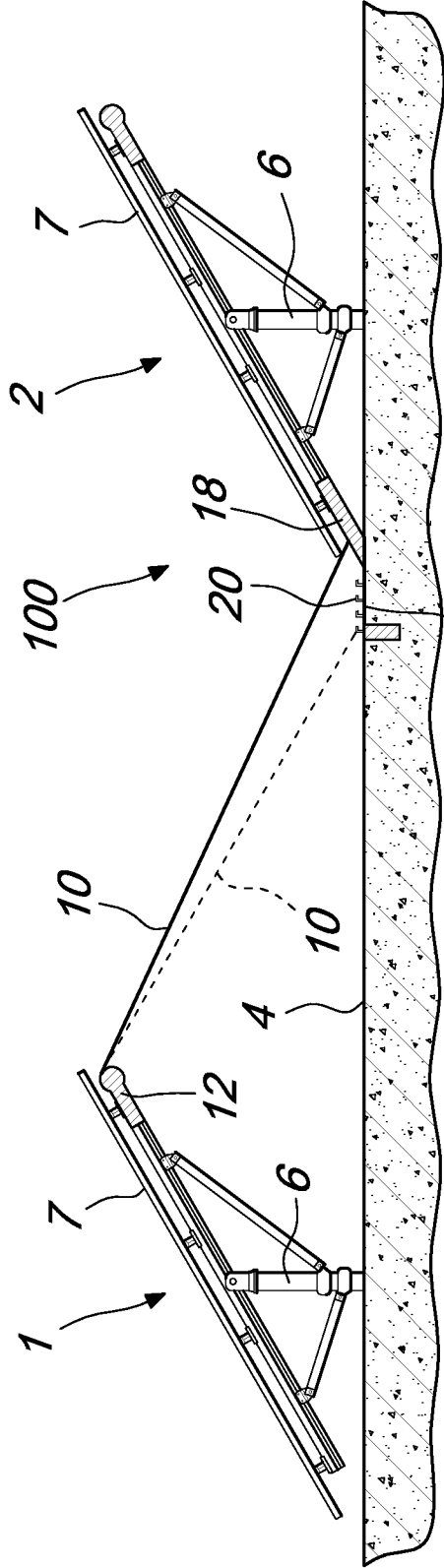

Fig. 6

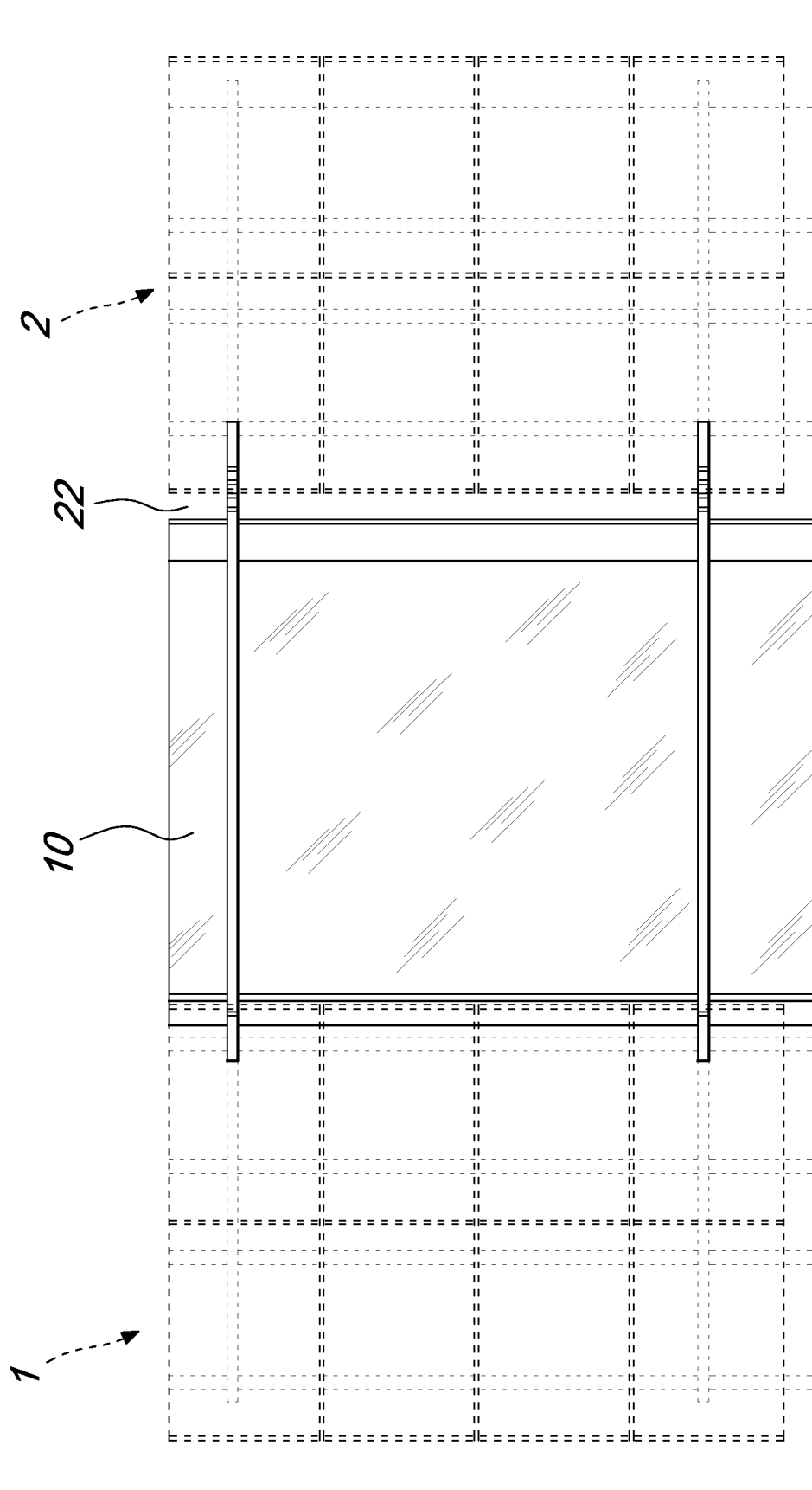

Fig. 7

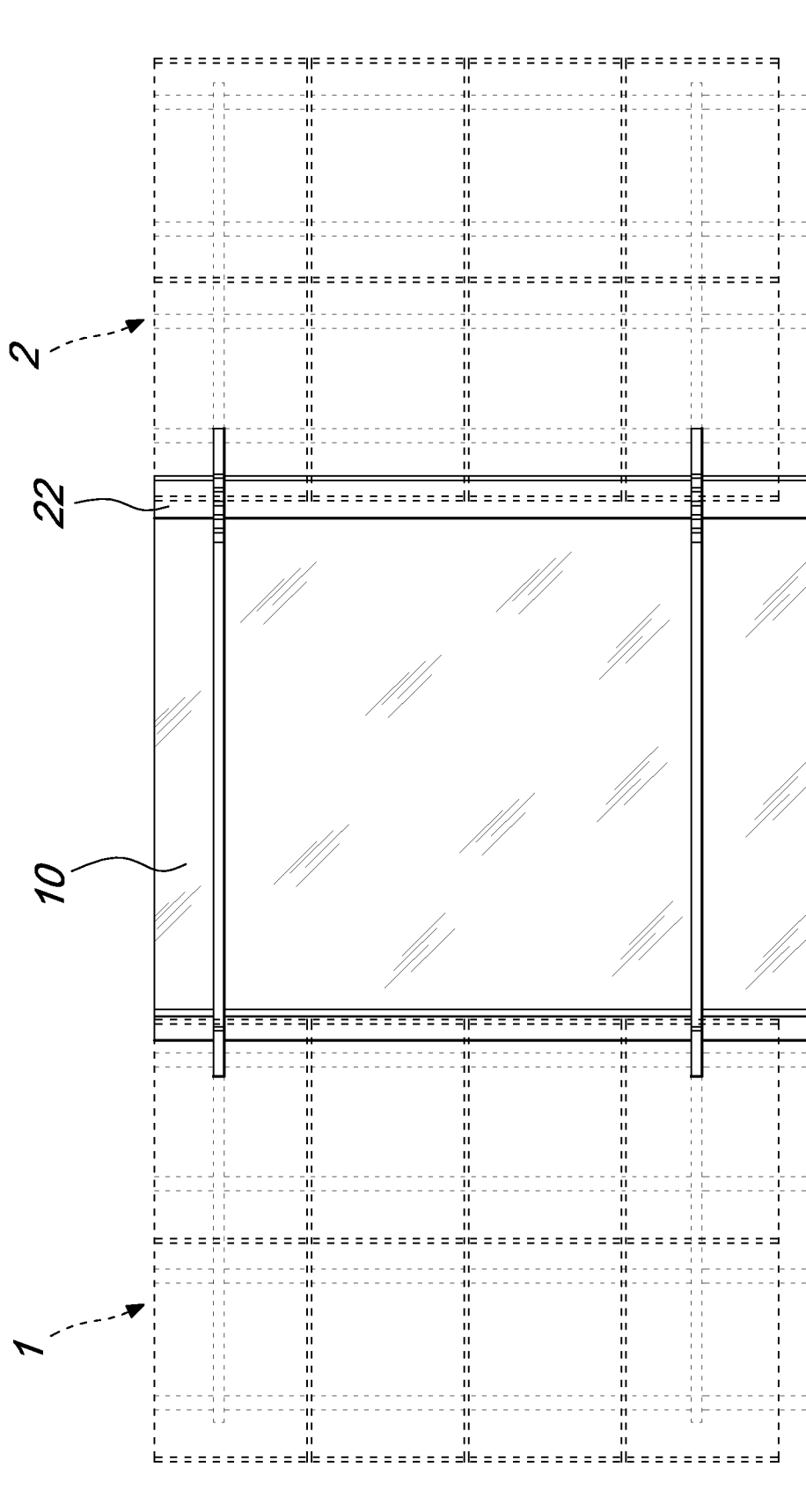

Fig. 8

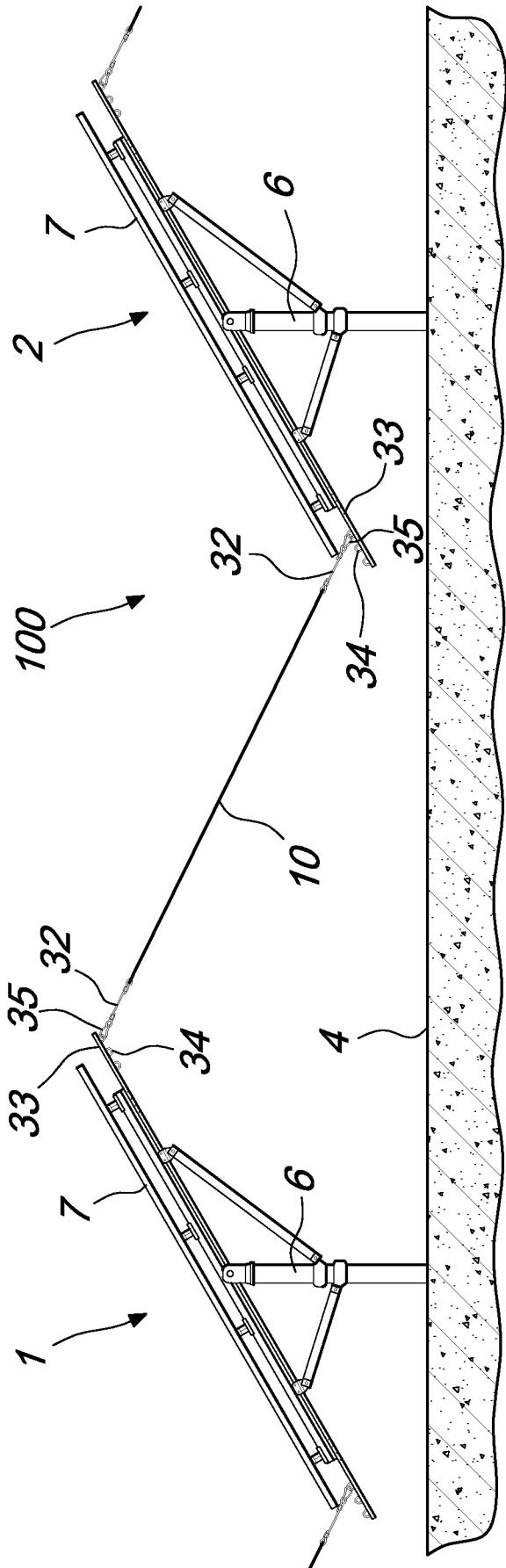

Fig. 9

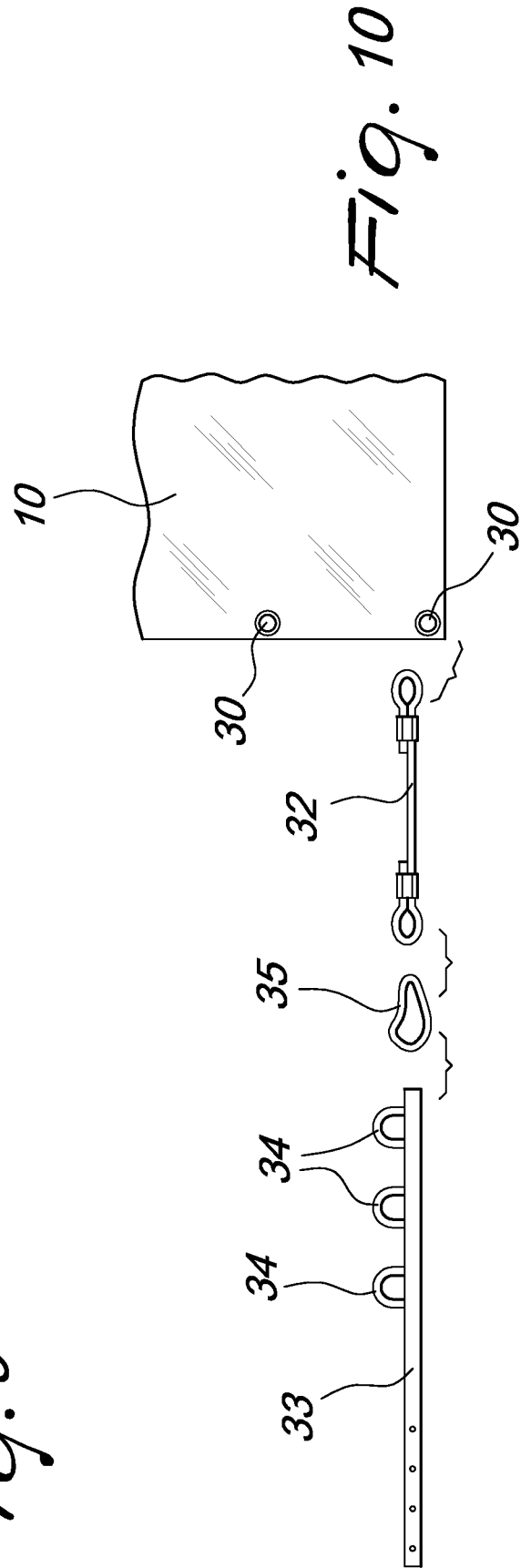

Fig. 10