

H. G. UNDERWOOD.
DISPATCH TUBE SYSTEM.

No. 524,006.

Patented Aug. 7, 1894.

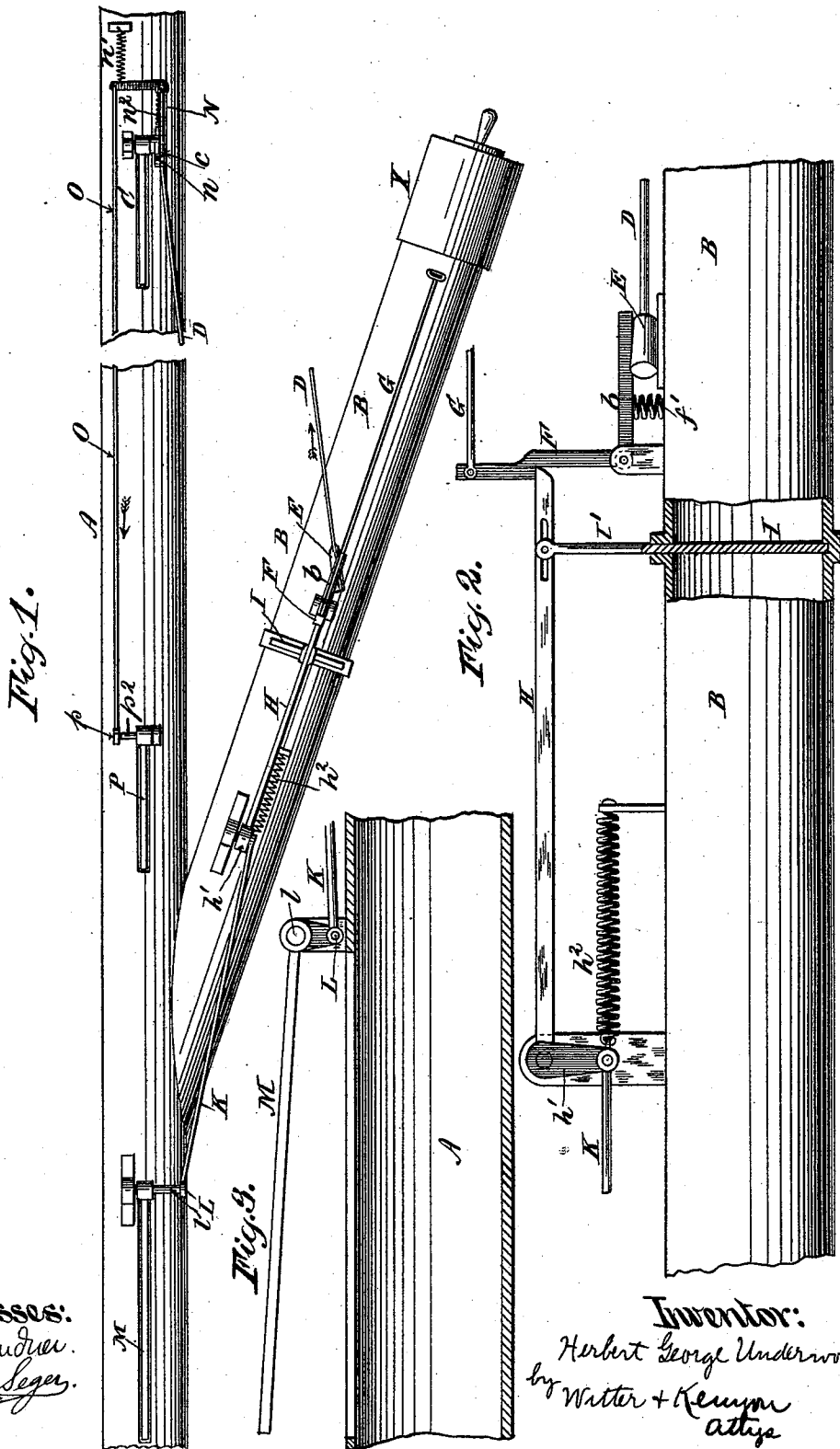

Witnesses:
D. W. Gardner.
Edwin Seeger.

Inventor:
Herbert George Underwood
by Walter + Kemper
attys

H. G. UNDERWOOD.
DISPATCH TUBE SYSTEM.

No. 524,006.

Patented Aug. 7, 1894.

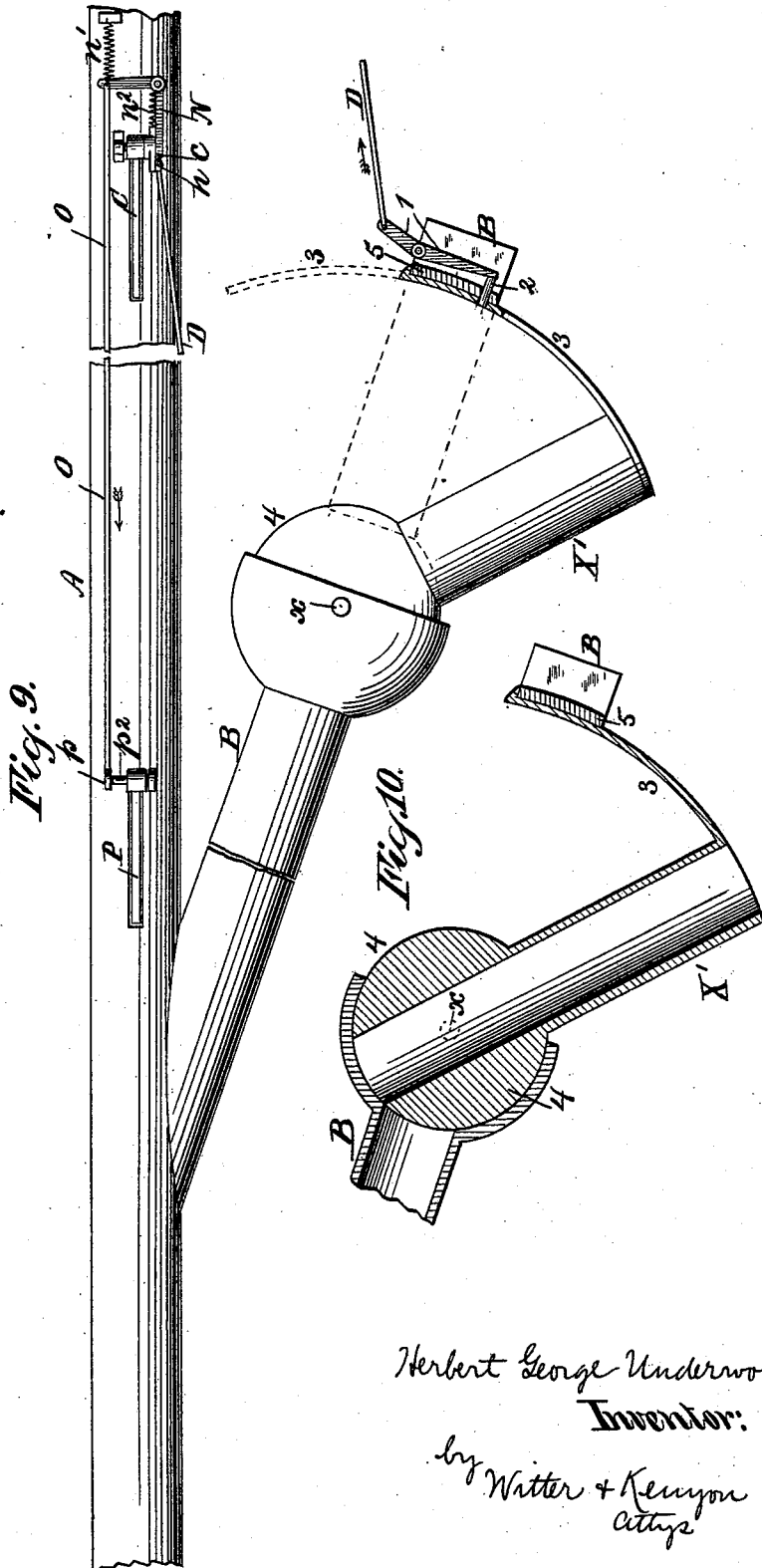

Witnesses:
D. W. Gardner.
Edwin Segal

Herbert George Underwood
Inventor:
by Witter & Kenyon
Attys

UNITED STATES PATENT OFFICE.

HERBERT G. UNDERWOOD, OF YONKERS, NEW YORK, ASSIGNOR TO THE COLLINS AUTOMATIC PNEUMATIC SWITCHING TUBES COMPANY, OF NEW JERSEY.

DISPATCH-TUBE SYSTEM.

SPECIFICATION forming part of Letters Patent No. 524,006, dated August 7, 1894.

Application filed December 19, 1892. Serial No. 455,674. (No model.)

To all whom it may concern:

Be it known that I, HERBERT GEORGE UNDERWOOD, a citizen of the United States, and a resident of the city of Yonkers, in the county of Westchester and State of New York, have invented certain new and useful Improvements in Dispatch-Tube Systems, of which the following is a specification.

This invention relates to tubes through which carriers are dispatched by pneumatic pressure, suction or other suitable motive force, and has for its object to prevent collisions between carriers either at the junction of tubes or elsewhere in the system, and consists of the improvements hereinafter more specifically described and claimed.

The preferred forms of my device are shown in the drawings, in all of which drawings similar letters and figures indicate corresponding parts.

Figures 1 and 9 are plan views of my improvements in use at the junction of two or more tubes, Fig. 1 showing the locking device as applied to a gate, and Fig. 9 showing it as applied directly to the sender. Fig. 2 is a vertical elevation, partly in section, of the gate in one tube, and Fig. 3 a vertical elevation, partly in section, of a device in the other tube for closing said gate. Figs. 4 and 5 are, respectively, a vertical elevation, partly in section, and a plan of the device for locking the gate. Figs. 6 and 7 are, respectively, a vertical elevation, partly in section, and a plan of my improved device for retarding carriers. Fig. 8 is a vertical cross-section of the tube A, taken through *t* Fig. 6 and Fig. 10 is a sectional view of one form of sender.

In the apparatus shown in the drawings, A is a main tube and B a branch tube.

I is a gate for closing the branch tube B, situated at a suitable distance from the junction of the tubes B and A. The arm *I'* of the gate is secured into the slot of the lever arm H as shown in Fig. 2. The arms H and *h'* are secured together or made integral with each other, and pivoted as shown in Fig. 2 so that as they swing on the pivot, H is lowered or raised, thus closing or opening the gate I. A spring *h²* is fastened to the end of *h'*, and tends therefore to open the gate I.

The arm H and the gate I are normally held down and closed by means of the latch F.

G is a rod attached to the upper end of the latch F and having a handle as shown in Fig. 1.

As shown in the drawings the branch tube B has a station X where carriers can be inserted into the branch tube and be thence dispatched through the system.

When the handle G is pulled by the operator it releases the arm H from the latch F and the spring *h²* opens the gate I. The operator can then insert the carrier into the sender X and dispatch it through the tube. The latch F has an arm *b* made integral with it, and a spring *f'* which tends to throw the latch F toward the arm H.

In the main tube A at a suitable distance from the junction, preferably at a considerable distance therefrom compared to the location of the gate I in the branch tube, a finger C depends or projects down slightly into the tube A as shown in Figs. 1 and 4. At its upper end the finger C is secured to the lever *c*. To one end of the lever *c* is pivotally secured an arm D, and to the other end a spring *n²* as shown in Fig. 4. The arm D has at its farther end an enlarged portion E shown clearly in Figs. 1 and 2. The finger C is normally held by the spring *n²* so that it projects slightly into the tube A. In this position the enlarged end E of the rod D lies back and beyond the arm *b*. When a carrier passes through the main tube A it forces the finger C upward, and through the lever *c*, pulls the rod D forward until its enlarged end E is pulled under the arm *b*. In this position E prevents the latch F from being pulled by the arm G off from the lever H, and thus locks the gate I in its closed position. The end E is held in this position by means of the catch *n* on the bell-crank N shown in Fig. 5. The bell-crank N is pivoted at its center, and the catch *n* is held against the lever *c* by means of the spring *n'* at the opposite end of the bell-crank N. To this same end of the bell-crank is fastened an arm O which connects with a short arm *p* keyed upon a shaft *p²*, upon which shaft is also keyed a finger P which projects downward

into the tube A in the same manner as the finger C. The finger P and the arm p are arranged relatively to each other as are the finger W and the arm w in Fig. 6, so that when a carrier strikes the finger P it lifts it up, moving the arm p and the rod O in the direction of the arrow in Fig. 1. This pulls the bell-crank in the same direction and pulls the catch n away from the lever c , thus releasing the latter.

Connected to the lower end of the arm h' is the rod K. The other end of the rod K is pivoted to the arm L, which latter is keyed upon the shaft l in the main tube a short distance beyond the junction of the tubes A and B. At the other end of the shaft l is keyed the finger M. The finger M works on the shaft l upward and downward. It is normally held out of the line of the tube A as shown in Fig. 3. An opening in the upper part of the tube A permits it to be lowered slightly into the tube. This is done when the arm K is pulled forward by the raising of the gate I.

The mode of operation of the above described form of my improvement is as follows: When the operator at X desires to insert a carrier in the branch tube B, he pulls the rod G, thus releasing H from the latch F, whereupon the spring h^2 at once raises the gate I and opens the branch tube B for the passage of the carrier. As the arm h' is pulled forward by the spring h^2 , the rod K is likewise pulled forward, thus, through the shaft l throwing the finger M downward into the tube A immediately beyond the junction of the tubes A and B. The carrier inserted at X passes through the open gate, down the branch tube B and out into the main tube A, there striking and raising the finger M, and thus through l , L, the rod K, the arm h' and the lever H, closing the gate I which is immediately locked in its closed position by the latch F. This is the operation when no carrier is passing down the main tube A. If, however, before the operator pulls the rod G, a carrier has reached and passed the finger C in the main tube A, the operation is as follows: The carrier raises the finger C, lifting the lever c and pulling the arm D forward in the direction of the arrow, thus swinging the enlarged end E of this arm under the arm b . The catch n of the bell-crank N snaps over the notch in the lever c and thus, through the spring n' , locks and holds the end E under the arm b . In this position of E the latch F cannot be released from the arm H even if the operator pulls upon the arm G. The gate I is thus locked in position and the operator cannot send a carrier through the branch tube B. I thus avoid all danger of collision between carriers at the junction of the tubes A and B. The locking device E is removed from this position to its normal one in the following manner: The carrier in the main tube which has thus locked the gate I strikes the finger P which is placed at some conven-

ient location at or near the junction of the two tubes, forces the finger P upward, and thus through the shaft p^2 , the lever arm p , the rod O, the bell-crank N, pulls the catch n away from the lever c , when the latter is at once restored to its normal position by means of the spring n^2 throwing the arm D in the reverse direction to that of the arrow, and pushing the enlarged end E out from and beyond the arm b of the latch F, and also throwing the finger C downward again into the tube A. The gate I can now be opened by the operator through the rod G and the latch F.

I do not limit myself to the precise location of the gate shown in the drawings or to the precise devices there shown for locking or unlocking or for opening or keeping the same closed, as these may be widely varied by persons skilled in this art without departing from the spirit of my invention.

Where a station is located in a branch tube near its junction with the main or another branch tube, my improved locking device may be so arranged as to lock the sender itself instead of locking a gate in the branch tube, and by this locking of the branch tube prevent carriers from being inserted into the branch tube while a carrier is passing in the main tube. Figs 9 and 10 show such a form of my improved device. X' is the sender. It consists of a short tube section pivoted at x where it connects with the end of the branch tube B by a sort of a ball and socket joint, so that it can be thrown either into line with the tube B as shown in dotted lines in Fig. 9, or entirely out of connection with it as shown in Fig. 10. The latter is its normal position and in this position the solid part 4 of the ball and socket joint closes the end of the tube B and effectually prevents the escape of air therefrom. The sender X' has attached to it a plate 3 which, as the sender is shifted backward and forward, reciprocates across the end 5 of the extension of the branch tube B. Mounted upon this part of the tube B is a bell-crank 1, pivoted as shown, pivotally secured at one end to the arm D and carrying at the other end a pin 2. The plate 3 has one or more holes or openings through which this pin 2 can pass as shown in Fig. 9. Normally the pin is withdrawn from the hole or opening in the plate 3, and in this position of the pin 2 the sender X' can be opened and closed at will, and carriers can be dispatched down the tube B. When the carrier in the tube A strikes the finger C, it pulls the rod D in the direction of the arrow, Fig. 9, as before described, and through the bell-crank 1 pushes the pin 2 into the hole in the plate 3. This locks the sender and prevents the insertion of a carrier into the branch tube B. The pin 2 is withdrawn when the carrier in the main tube strikes the finger P, in the manner already described.

The form of sender shown in Figs. 9 and 10 is described and claimed in an application now pending in the Patent Office, filed by me

on the 30th day of November, 1892, Serial No. 453,619, and is therefore not claimed in this application.

My locking device it is evident is capable of use with other forms of senders. When the locking device is applied directly to the sender, as shown in Figs. 9 and 10, instead of to a gate in the tube, as shown in Figs. 1, 2 and 3, the gate and its latch and lever connections and the finger M and its rod and lever connections can, as is evident, be all dispensed with.

Figs. 6 and 7 represent my improved device for preventing collisions at places in the main or branch tubes other than at the junction of such tubes. R is a finger which I preferably make of considerable length so that the blow of the carrier upon it will be diminished in force. It is pivoted at its upper end in an enlarged portion Z of the casing as shown in Fig. 6, and projects downward into the tube A. S is a spring, T is a short pivoted arm lying upon and across the finger R. The spring S is held normally upon and over the arm T. In this position of the spring S, it bears down with some weight upon the finger R through the arm T, so that a carrier is obliged in passing through the tube A to lift the finger R against the weight of the spring S. By this means its progress is somewhat retarded. Ordinarily the spring S occupies the position shown in the dotted lines in Fig. 7, where its bearing end rests upon the standard *t* and not at all upon the arm T, and therefore there is no weight upon the finger R. This finger R is light and is loosely pivoted so that in this position a carrier lifts it very readily and is not appreciably retarded in its course. As the finger R is thus forced upward by the carrier, it carries upward with it the loosely pivoted arm T until, at nearly the highest point of its motion, the latter strikes against the spring S and raises it slightly from the standard *t*, whereupon the spring *s*² forces the spring S over into the position shown in full lines in Fig. 7, where its full weight bears upon the finger R. If another carrier is immediately behind the first one, it will be retarded by this weight upon the arm R so that collision between it and the preceding carrier will thus be avoided. At a suitable distance farther on in the tube, a second finger W projects slightly into the tube A. It is pivoted to a short arm *w* in the manner shown in Fig. 6. The free end of the arm *w* is pivoted to a rod V, the latter at its other end being pivoted to the bell-crank *s*. At the end of the other arm of the bell-crank, the roller *s*¹ bears upon the side of the spring S. When the first carrier strikes finger W it pulls the rod V forward, throwing the bell-crank into the position shown in dotted lines in Fig. 7, and forcing the spring S into the position shown in dotted lines in the same figure. The finger R has now no weight upon it, and the next succeeding carrier to strike it will not

be retarded in its passage through the tube. When the spring S is in the position shown in dotted lines in Fig. 7, it is held in this position by a slight depression in the standard *t* as shown in Fig. 8. From this depression it is lifted by the next carrier when it raises the finger R and the arm T.

The fingers R can be placed at suitable distances apart or wherever needed in the main and branch tubes of the system, and the fingers W can be placed at suitable distances from said finger R. In this way collisions can be effectually avoided in any one or more tubes of the system.

What I claim as new, and desire to secure by Letters Patent, is—

1. In combination with a dispatch tube having a branch tube, a finger in one tube adapted to be struck by carriers, a sender on the other tube, a device for locking said sender, rod and lever connections between said locking device and said finger whereby, when the finger is struck by a carrier, the sender will be locked so that carriers cannot be inserted therein, substantially as set forth.

2. In combination with a dispatch tube having a branch tube, a finger in one tube adapted to be struck by carriers, a sender on the other tube, a device for locking said sender, rod and lever connections between said locking device and said finger whereby, when the finger is struck by a carrier, the sender will be locked so that carriers cannot be inserted therein, a second finger in said first mentioned tube, rod and lever connections between it and said first finger and locking device so arranged that when said second finger is struck by a carrier the sender will be unlocked, substantially as set forth.

3. In combination with a dispatch tube having a branch tube, a gate in one tube, a latch to hold said gate closed, a projecting finger in the other tube, and a rod having an enlarged end and connected with said finger and said latch whereby, when said finger is struck by a carrier, the enlarged end of said rod will lock the latch and gate, substantially as shown and described.

4. In combination with a dispatch tube having a branch tube, a gate in one tube, a projecting finger in the other tube, a rod for locking said gate when said projecting finger is struck by a carrier, a finger projecting into the tube beyond said gate and adapted to be struck by carriers passing through the tube containing the gate, and connecting arms and levers between said finger and gate whereby the latter is closed when said finger is struck by the carrier, substantially as shown and described.

5. In combination with a dispatch tube having a branch tube, a gate in one tube, a projecting finger in the other tube, a rod for locking said gate when said projecting finger is struck by a carrier, a catch for holding said finger and rod in their locking position, a second finger in said other tube, rod and lever

connections between it and said catch whereby said catch is released and said first finger and locking rod are permitted to return to their normal positions when said second finger is struck by the carrier, substantially as shown and described.

6. In combination with a dispatch tube having a branch tube, a gate in one tube, a projecting finger in the other tube, a rod for locking said gate when said projecting arm is struck by a carrier, a catch for holding said finger and rod in their locking position, a spring for returning them to their normal positions, a second finger in said other tube, rod and lever connections between it and said catch whereby said catch is released and said first finger and locking device are forced by the spring back to their normal positions when said second finger is struck by the carrier, substantially as shown and described.

7. In combination with a dispatch tube having a branch tube, a gate in one tube, a projecting finger in the other tube, a lever arm to which said finger is secured, a rod pivoted to one end of said lever having an enlarged end for locking the gate, a spring fastened to the other end of said lever to hold said finger and locking rod in their normal positions, a spring catch for holding said finger and rod in their locking position, a second finger farther on in the same tube, rod and lever connections between it and the catch whereby when said second finger is struck by the carrier, said catch is released and the first finger and rod are returned to their normal positions and the gate is unlocked, substantially as shown and described.

8. In combination with a dispatch tube having a branch tube, a gate in one tube, a latch for holding the gate in one position, a spring for returning it to the other position, a projecting finger in the other tube, and a rod connected with said finger for locking said gate when said finger is struck by the carrier, substantially as shown and described.

9. In combination with a dispatch tube having a branch tube, a gate in one tube, a latch for holding the gate closed, a spring for opening said gate when said latch is released, means for releasing said latch, a projecting finger in the other tube, a rod connected with said finger for locking said gate when said finger is struck by the carrier, substantially as shown and described.

10. In combination with a dispatch tube having a branch tube, a gate in one tube, a latch for holding the gate closed, a spring for opening said gate when said latch is released, a rod for releasing said latch, a projecting finger in the other tube, a rod connected with said finger for locking said gate when said finger is struck by the carrier, substantially as shown and described.

11. In combination with a dispatch tube having a branch tube, a gate in one tube, a lever connected with the gate for opening and closing it, a spring latch adapted to hold said

lever and keep the gate closed, a spring connected with said lever adapted to open said gate, a rod connected to the latch to release the same, a projecting finger in the other tube, a rod connected with said finger for locking said latch when the projecting finger is struck by the carrier, substantially as shown and described.

12. In combination with a dispatch tube having a branch tube, a gate in one tube, a lever connected with the gate for opening and closing it, a spring latch adapted to hold said lever and keep the gate closed, a spring connected with said lever adapted to open said gate, a rod connected to the latch to release the same, a projecting finger in the other tube, a rod connected with said finger for locking said latch when the projecting finger is struck by the carrier, a second finger projecting into either tube beyond the gate adapted to be struck by carriers passing through the tube in which the gate is located, rod and lever connections between it and the lever connected with the gate, whereby when the said finger is struck by said carriers the gate will be closed, substantially as shown and described.

13. In combination with a dispatch tube having a branch tube, a gate in one tube, a lever connected with the gate for opening and closing it, a spring latch adapted to hold said lever and keep the gate closed, a spring connected with said lever adapted to open said gate, a rod connected to the latch to release the same, a finger M adapted to be struck by carriers passing through the tube in which the gate is located, rod and lever connections between it and the lever connected with the gate, whereby when the said finger is struck by said carriers the gate will be closed, the finger C, a lever arm to which said finger is secured, a rod pivoted to one end of said lever having an enlarged end for locking the gate, a spring fastened to the other end of said lever to hold said finger and locking rod in their normal position, a spring catch for holding said lever, finger and rod in their locking position, a second finger farther on in the said tube, rod and lever connections between it and the catch whereby when said second finger is struck by a carrier said catch is released, and the finger C and rod are returned to their normal positions and the gate is unlocked, substantially as shown and described.

14. In a dispatch tube a pendent arm or finger and a spring normally withdrawn from said finger but adapted to be moved by the carrier so as to bear upon said finger to retard the progress of a succeeding carrier, substantially as shown and described.

15. In a dispatch tube a pendent arm or finger, a movable spring and means automatically actuated by carriers for throwing the same upon or off from the arm or finger, substantially as shown and described.

16. In a dispatch tube a pendent arm or finger, a movable spring adapted in one position

to bear upon and depress said finger, a second pendent arm or finger farther on in the tube, a bell-crank bearing against the spring, and rod and lever connections between said bell-crank and said second finger whereby, when said second finger is struck by the carrier, the spring is forced off from the first finger, substantially as shown and described.

17. In a dispatch tube a pendent arm R, hinged rod T resting thereon, standard *t*, spring S, pivoted at one end and having its free end movable so as to be adapted to press either upon rod T or standard *t*, spring *s*² for

holding spring S upon rod T, bell-crank *s* having one end adapted to press upon spring S, rod V connected to the other end of bell-crank *s*, arm *w* of bell-crank W connected to rod V, and pendent arm W adapted when struck by a carrier to force spring S off from rod T and upon standard *t*, substantially as set forth.

HERBERT G. UNDERWOOD.

Witnesses:

HUGO J. WEBER,
EDWIN SEGER.