

Feb. 28, 1956

A. R. MURRAY  
GYROSCOPIC FIGURE TOY  
Filed Feb. 12, 1954

2,736,132

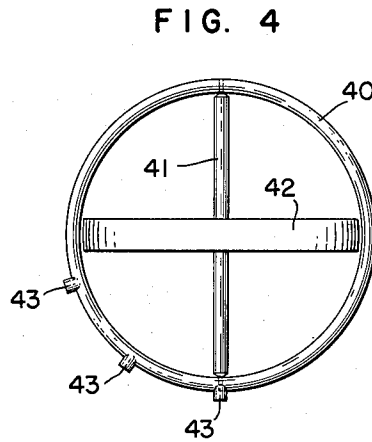
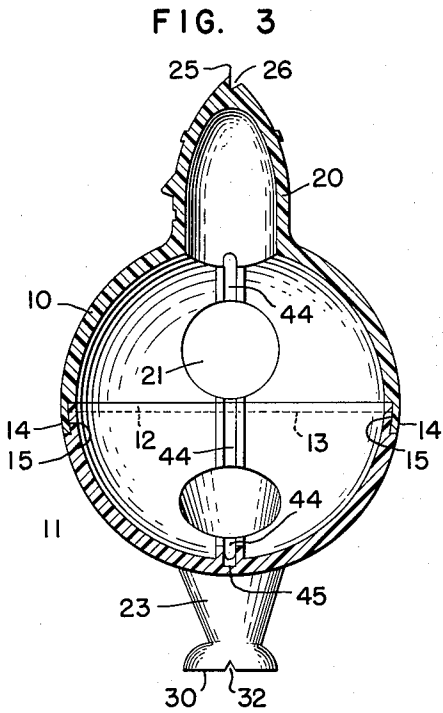
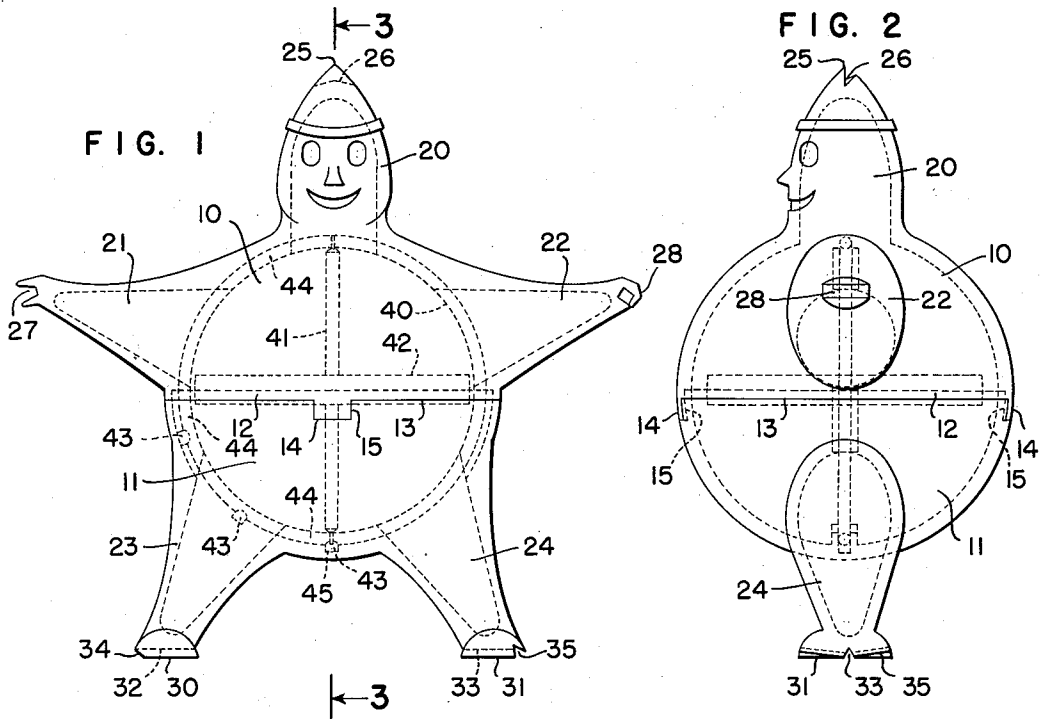

INVENTOR.  
ALBERT RODNEY MURRAY

BY

*Jas. C. Hobensmith*  
ATTORNEY.

1

2,736,132

## GYROSCOPIC FIGURE TOY

Albert Rodney Murray, Oreland, Pa.

Application February 12, 1954, Serial No. 409,858

6 Claims. (Cl. 46—50)

This invention relates to gyroscopic toys, and it relates more particularly to a figure toy having a plurality of extensions upon any one of which the figure may be balanced accordingly as the gyroscope is disposed within the interior thereof.

The principal object of the present invention is to provide a novel form of figure toy which may be used in an interesting variety of ways for the amusement and edification of the user and spectators.

A further object of the invention is to provide a gyroscopic figure toy having a plurality of extensions upon either of which the toy may be maintained in a variety of positions upon a flat surface, upon a thin edged device, or upon a taut string.

A further object of the invention is to provide a toy of the character aforesaid, which will be simple and efficient in its action and devoid of complications in its operation.

A further object of the invention is to provide a toy of the character aforesaid, which will be relatively inexpensive in its construction.

The nature and characteristic features of the invention will be more readily understood from the following description, taken in connection with the accompanying drawing forming part hereof, in which:

Figure 1 is a front elevation of a gyroscopic figure toy embodying the main features of the present invention;

Fig. 2 is a side elevation thereof;

Fig. 3 is a vertical section thereof taken approximately on the line 3—3 of Fig. 1, but with the gyroscope removed; and

Fig. 4 is an elevational view of a gyroscope of a common form adaptable for use in connection with the invention and having certain additional parts for the utilization of the same in the figure shown.

It should, of course, be understood that the description and drawing herein are illustrative merely, and that various changes and modifications may be made in the structure disclosed without departing from the spirit of the invention, and particularly that the figure may assume a variety of forms other than that shown.

Referring to the drawing, the body of the toy is preferably made of molded plastic, such material being particularly adaptable for the formation thereof.

The body portion of the figure shown is globular in shape, the same having a hollow interior for the disposition therein of a gyroscope of a type to be presently described.

The body portion of the figure is preferably made in two parts, 10 and 11, separable, when the toy is upright, in a horizontal plane so as to provide access to the hollow interior. One portion 10 of the body of the figure may be provided with an annular lip 12 adapted to be seated in an annular recess 13 around the top of the other portion 11. The portion 10 of the body may also be provided with lugs 14 disposed diametrically opposite and each extending into a complementally shaped recess 15 in the other body portion 11.

The lugs 14 extend a sufficient distance past the join-

2

ing plane to effect a snap action in the separation or uniting of the parts 10 and 11.

As shown, the figure may be provided with a plurality of radial extensions. For example, one such extension 20 may be shaped to simulate the head of a person, two such extensions 21 and 22 may be shaped to simulate the arms of a person, and two such extensions 23 and 24 may be shaped to simulate the legs of a person.

The extensions 20, 21, 22, 23 and 24 are preferably formed and shaped whereby the extremities thereof will be substantially equally spaced angularly in a common plane, and each of said extensions may be shaped at its end in a suitable manner so as to permit the device to be used in various ways, as will be hereinafter more fully set forth.

For example, the extremity of the head simulating portion 20 may terminate in a point 25 adjacent which there may be provided a groove 26 whereby, when the toy is used in an inverted position, the point 25 thereof may be disposed on a flat surface, or the groove 26 may be used to permit the inverted head to be mounted on a taut string.

Likewise, one of the arms 21 may be transversely grooved as at 27 to engage the edge of a thin ruler or a string, when said arm 21 is disposed vertically downward, whereas the other arm 22 may have a flattened portion 28 at its end for the purpose of arranging the figure in a position with said arm 22 disposed vertically downward and placed on a flat surface.

The extremities of each of the legs 23 and 24 may be provided with flat surfaces 30 and 31, respectively, whereby the toy may be placed upon a flat surface, in an upright position, as shown in Figs. 1 and 2 of the drawing.

Each of the legs 23 and 24 may be also provided with a groove 32 and 33 located in alignment in the main vertical plane of the toy whereby the toy may be disposed in an upright position upon a taut string.

On the other hand, one of the leg extensions 23 is provided with another flat surface 34 for placing the toy upon a flat surface with the axis of the body which passes through the head disposed at an angle to the axis of said leg 23 when the same is placed vertically.

The other leg 24 of the device is provided with a transverse groove 35 for the purpose of placing the toy upon a taut string with the main axis of the body portion disposed at an angle to the vertical when the axis of said leg 24 is disposed vertically.

It will, of course, be understood that various other shapes and formations of the end portions of the extensions may be used if desired for maintaining the toy in various positions and under various conditions.

For the purpose of maintaining the balance of the figure, either upon a flat surface, or upon a straight edged ruler, or upon a taut string, whichever may be used, there is provided a gyroscope of a well known form comprising a ring-like frame 40 in which the spindle 41 of the gyroscope wheel 42 is journaled. However, the usual ring-like frame 40 of the gyroscope is provided with a plurality of lugs 43 angularly spaced and each extending radially outward a short distance.

The interior of the hollow body of the figure is provided with a series of suitably shaped recesses 44 located to receive the ring-like frame 40 of the gyroscope, and in the portion of the body between the leg extensions 23 and 24 there is an additional recess 45 complemental to and adapted to receive one of the lugs 43 which are provided on the frame 40 of the gyroscope, it being noted that the lugs 43 are spaced from each other at proper angular distances so that the axis of the gyroscope spindle 41 may be brought into coincidence with the axis of any one of the radial extensions 20, 21, 22, 23 and 24, according to

3

the desire of the user, for maintaining the toy in the desired position.

The gyroscope may be and preferably is operated in the usual manner by means of a string wound on the spindle by hand. The parts of the figure being separated, the running gyroscope is inserted in the hollow interior of the figure with the axis of the spindle in the desired angular position as determined by the placing of the proper lug 43 in the recess 45.

After the gyroscope is placed within the interior of the part 11 of the figure in the desired position, the other part 10 of the figure is placed in position on the part 11, and the device is then in condition for operation.

By the foregoing arrangement there is provided a novel and interesting toy by means of which considerable amusement and some mystification will be provided by those operating or viewing the same when it is in operation.

I claim:

1. A gyroscopic figure toy comprising a hollow body, a plurality of extensions projecting from said body in separated axes, each of said extensions comprising a component portion of the figure simulated by the toy, a gyroscope adapted to be placed within the interior of the body, and means for mounting said gyroscope in selective positions therein with the axis of its spindle in coincidence with the axis of any one of the extensions.

2. A gyroscopic figure toy comprising a hollow separable globular body, a plurality of extensions projecting from said body and disposed in a common plane in separated axes, each of said extensions comprising a component portion of the figure simulated by the toy, a gyroscope adapted to be placed within the interior of the body, and means for mounting said gyroscope in selective positions therein with the axis of its spindle in coincidence with the axis of any one of the extensions.

3. A gyroscopic figure toy comprising a hollow separable globular body, a plurality of extensions projecting from said body and disposed in a common plane in substantially equally spaced angular positions, each of said extensions comprising a component portion of the figure simulated by the toy, a gyroscope adapted to be placed within the interior of the body, and means for mounting said gyroscope in selective positions therein with the axis

4

of its spindle in coincidence with the axis of any one of the extensions.

4. A gyroscopic figure toy comprising a hollow separable globular body, a plurality of extensions projecting from said body and disposed in a common plane in substantially equally spaced angular positions, each of said extensions comprising a component portion of the figure simulated by the toy, the extremities of said projections being variously shaped, a gyroscope adapted to be placed within the interior of the body, and means for mounting said gyroscope in selective positions therein with the axis of its spindle in coincidence with the axis of any one of the extensions.

5. A gyroscopic animal figure toy comprising a hollow separable globular body, a plurality of extensions simulating the head and limbs of an animal, said extensions projecting from said body and disposed in a common plane in substantially equally spaced angular positions, the extremities of said projections being variously shaped whereby the device may be balanced on either a flat surface, on a thin edged device, or on a taut string, a gyroscope adapted to be placed within the interior of the body, and means for mounting said gyroscope in selective positions therein with the axis of its spindle in coincidence with the axis of any one of the extensions.

6. A gyroscopic figure toy comprising a hollow separable globular body, a plurality of extensions projecting from said body respectively simulating the head, arms, and legs of a person, said extensions being disposed in a common plane in substantially equally spaced angular positions, the extremities of said projections being variously shaped whereby the device may be balanced on either a flat surface, on a thin edged device, or on a taut string, a gyroscope adapted to be placed within the interior of the body, and means for mounting said gyroscope in selective positions therein with the axis of its spindle in coincidence with the axis of any one of the extensions.

#### References Cited in the file of this patent

#### UNITED STATES PATENTS

755,446	Butcher .....	Mar. 22, 1904
788,041	Fultz .....	Apr. 25, 1905
942,952	Wrather .....	Dec. 14, 1909