



US00D738270S

(12) **United States Design Patent**
Blanski et al.

(10) **Patent No.:** **US D738,270 S**

(45) **Date of Patent:** **** Sep. 8, 2015**

(54) **VEHICLE REAR UPPER BUMPER COVER**

(71) Applicant: **Ford Motor Company**, Dearborn, MI (US)

(72) Inventors: **Dillon R. Blanski**, Ferndale, MI (US);
Murat Gueler, Cologne (DE);
Christopher Hamilton, Cold Norton (GB)

(73) Assignee: **Ford Motor Company**, Dearborn, MI (US)

(**) Term: **14 Years**

(21) Appl. No.: **29/491,438**

(22) Filed: **May 21, 2014**

(51) **LOC (10) Cl.** **12-16**

(52) **U.S. Cl.**
USPC **D12/169**

(58) **Field of Classification Search**
USPC D12/169, 216, 90-92, 86, 171, 196,
D12/163; 293/102, 113, 115, 117, 120;
296/180.1, 180.2

CPC B60R 19/02; B60R 19/04; B62D 25/08
See application file for complete search history.

(56) **References Cited**

U.S. PATENT DOCUMENTS

D685,302 S *	7/2013	Futschik et al.	D12/169
D688,993 S *	9/2013	Campbell et al.	D12/169
D688,994 S *	9/2013	Campbell et al.	D12/169
D701,805 S *	4/2014	Campbell et al.	D12/169

* cited by examiner

Primary Examiner — Melody N Brown

(74) *Attorney, Agent, or Firm* — Damian Porcari

(57) **CLAIM**

The ornamental design for a vehicle rear upper bumper cover, as shown and described.

DESCRIPTION

FIG. 1 is a perspective view of a vehicle rear upper bumper cover;

FIG. 2 is another perspective view thereof;

FIG. 3 is a front elevational view thereof;

FIG. 4 is a left side elevational view thereof;

FIG. 5 is a right side elevational view thereof;

FIG. 6 is a top plan view thereof; and,

FIG. 7 is a bottom plan view thereof.

1 Claim, 7 Drawing Sheets

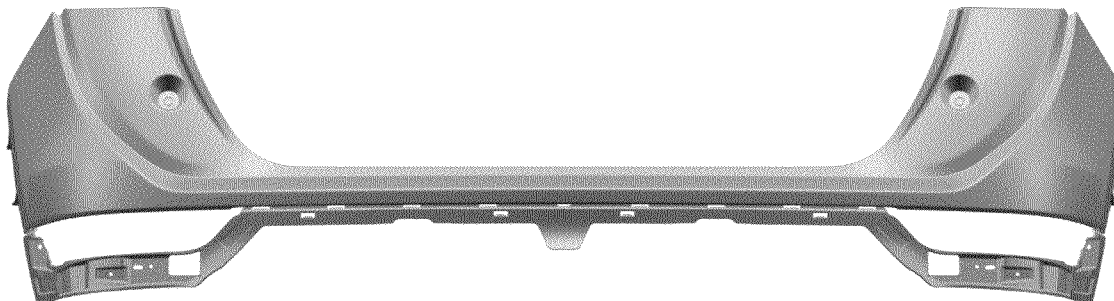

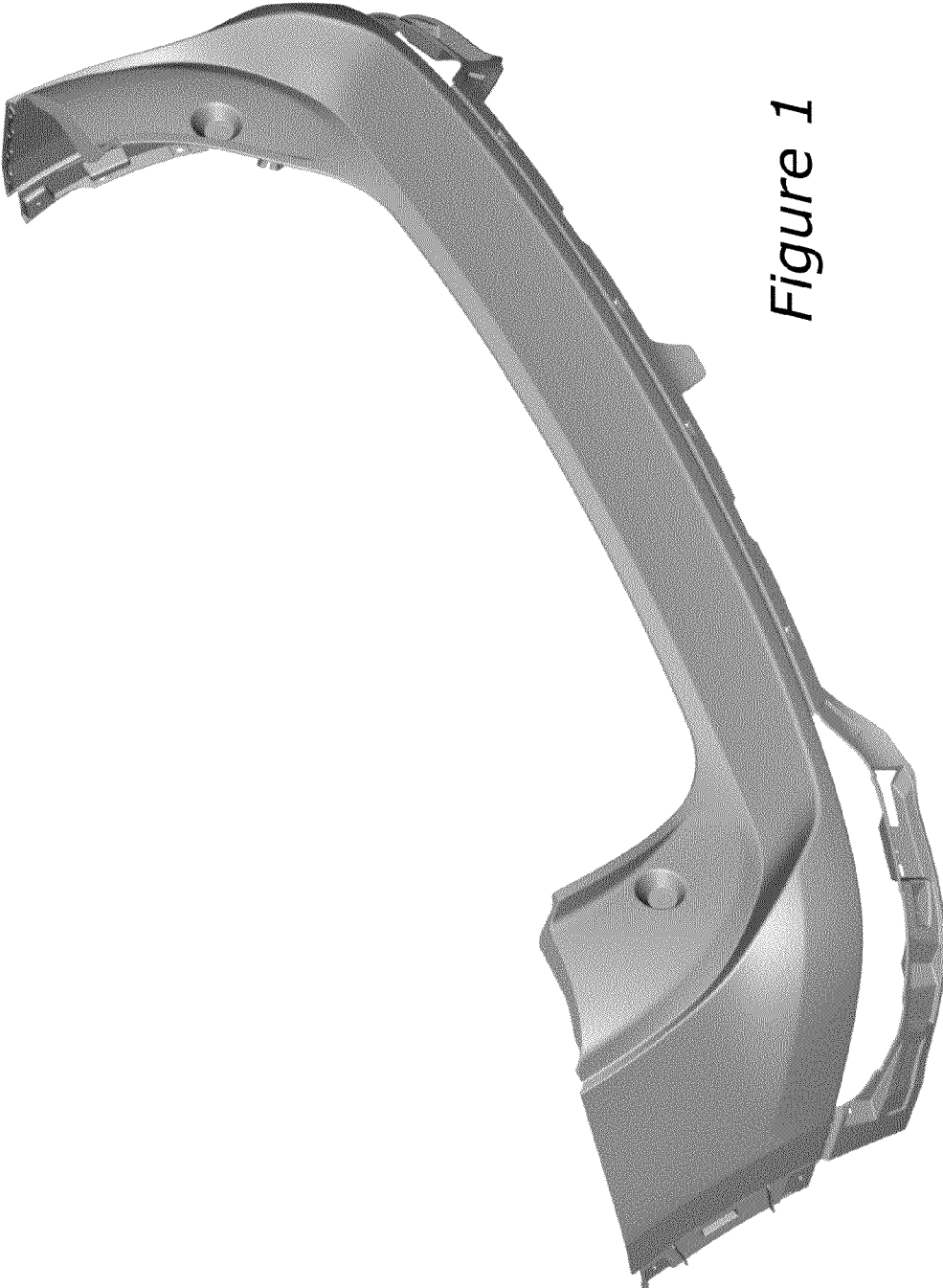

Figure 1

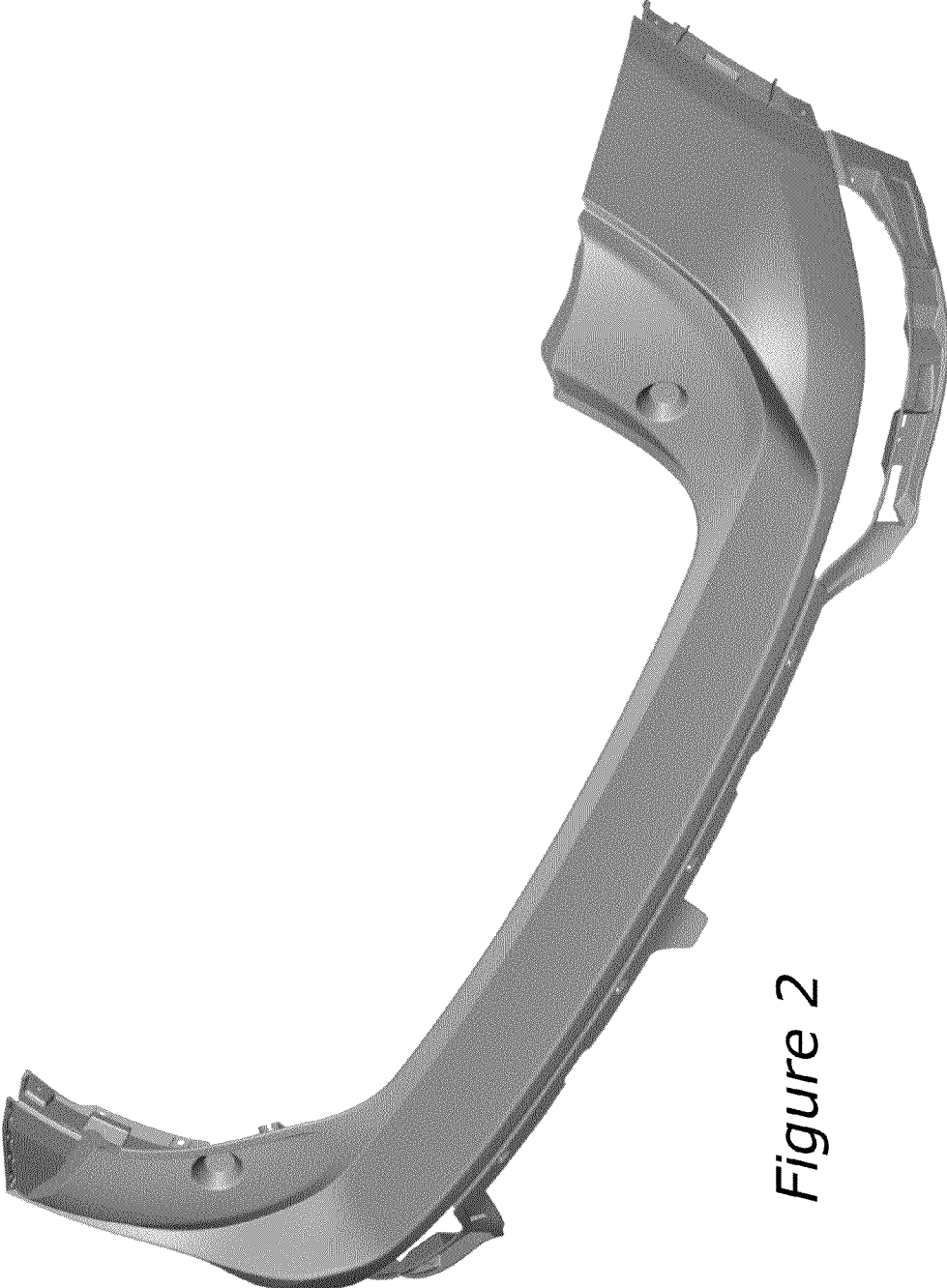

Figure 2

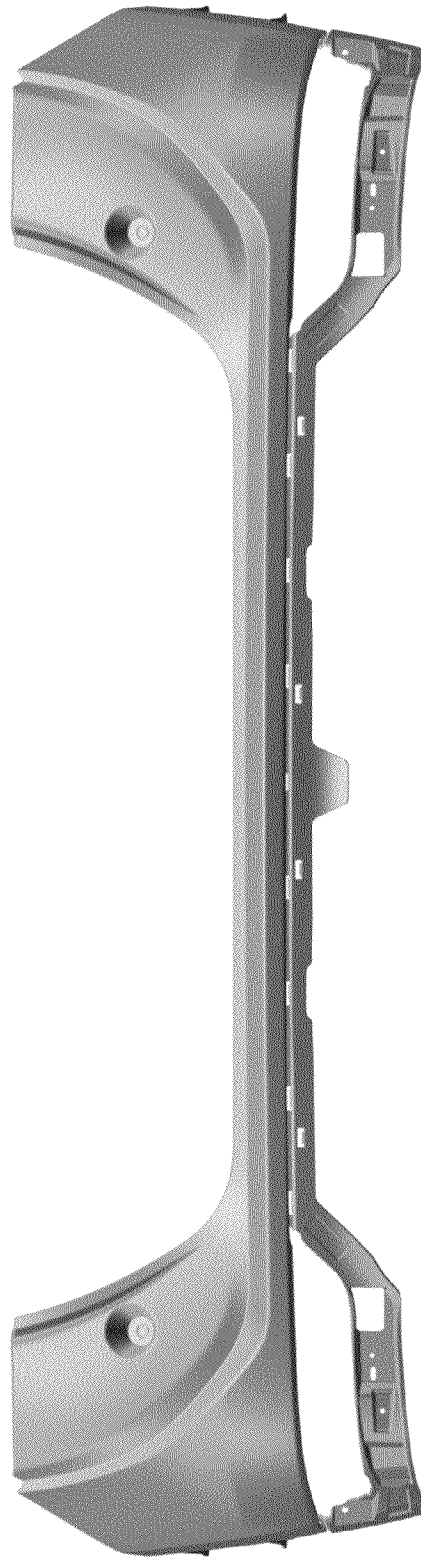

Figure 3

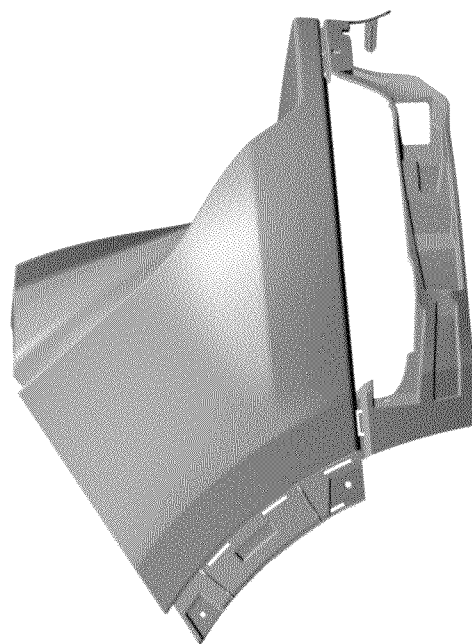

Figure 4

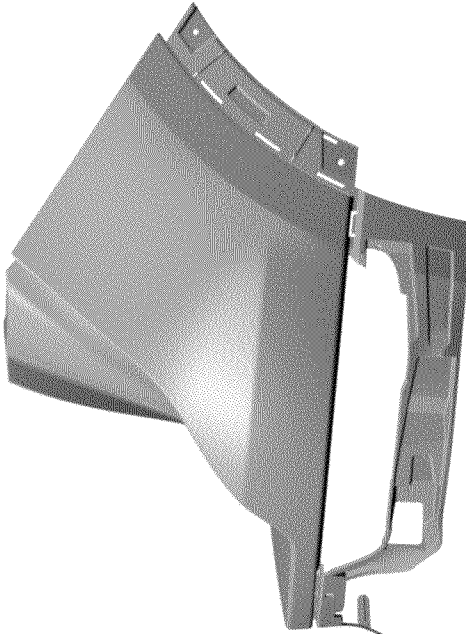

Figure 5

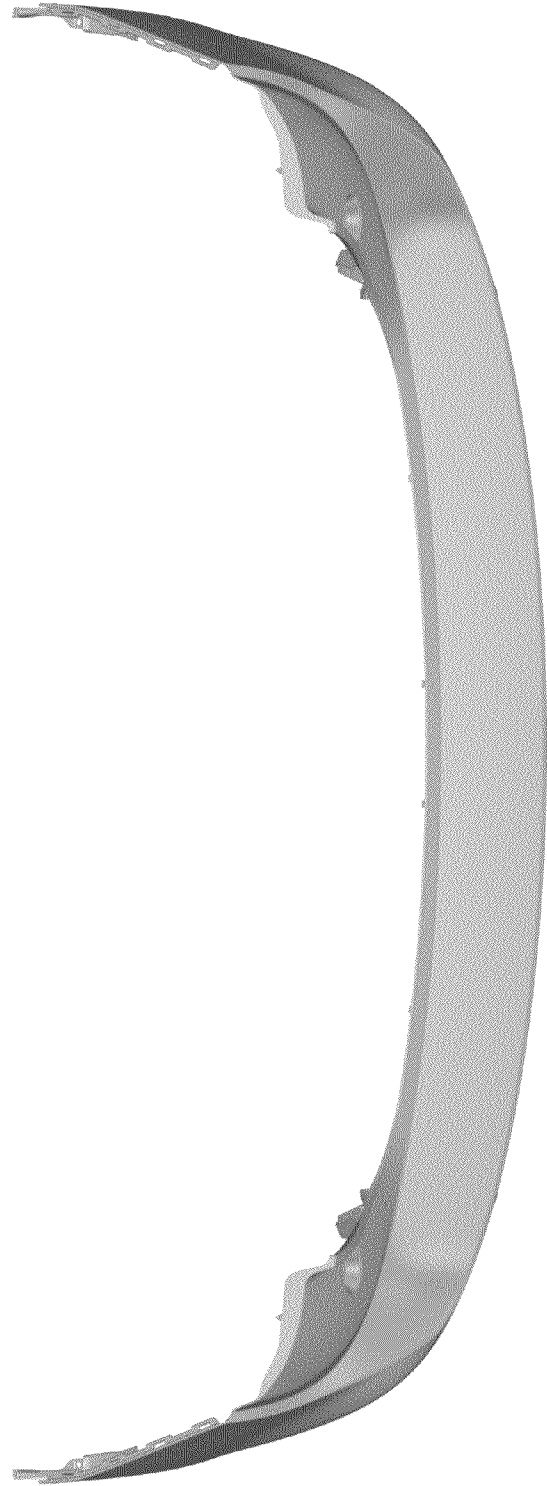

Figure 6

Figure 7

