



US 20140074164A1

(19) **United States**

(12) **Patent Application Publication**
Dreyfuss et al.

(10) **Pub. No.: US 2014/0074164 A1**
(43) **Pub. Date: Mar. 13, 2014**

(54) **SUTURE ANCHOR WITH APERTURES AT TIP**

(60) Provisional application No. 60/559,426, filed on Apr. 6, 2004.

(71) Applicant: **Arthrex, Inc.**, Naples, FL (US)

Publication Classification

(72) Inventors: **Peter J. Dreyfuss**, Naples, FL (US);
William C. Benavitz, Naples, FL (US)

(51) **Int. Cl.**
A61B 17/04 (2006.01)

(73) Assignee: **Arthrex, Inc.**, Naples, FL (US)

(52) **U.S. Cl.**
CPC **A61B 17/0401** (2013.01)
USPC **606/232**

(21) Appl. No.: **14/077,012**

(57) **ABSTRACT**

(22) Filed: **Nov. 11, 2013**

A suture anchor includes a threaded anchor body, at least one aperture at the distal end of the suture anchor, and at least one groove in communication with the aperture. A suture strand can be inserted into the suture anchor and pass through the aperture, the portion of the suture seated in the groove or grooves being protected from abrasion during installation of the suture anchor.

Related U.S. Application Data

(63) Continuation of application No. 11/097,180, filed on Apr. 4, 2005, now Pat. No. 8,579,940.

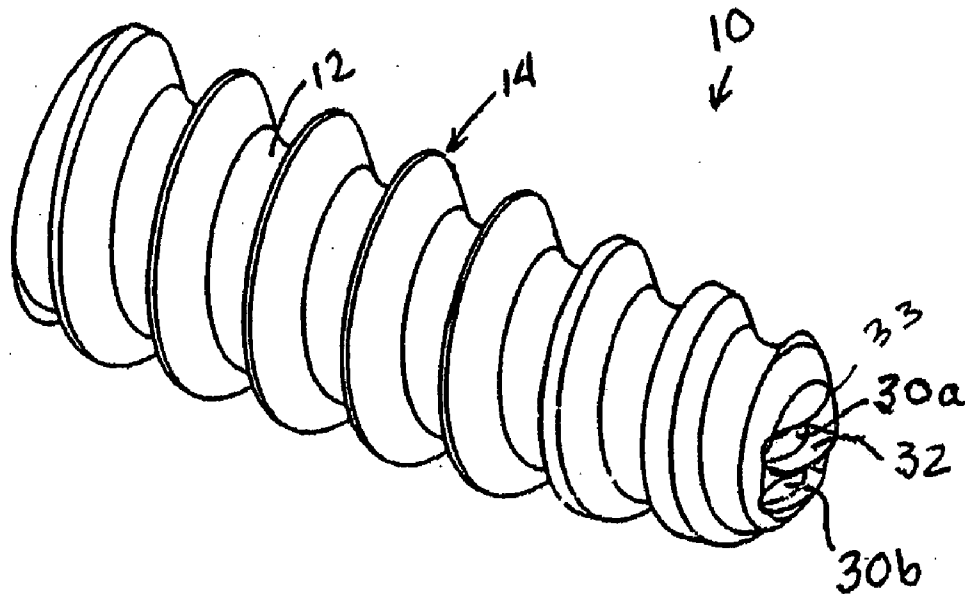

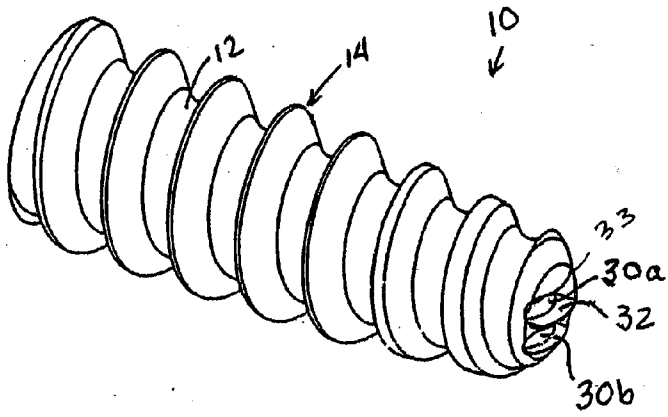

FIG. 1

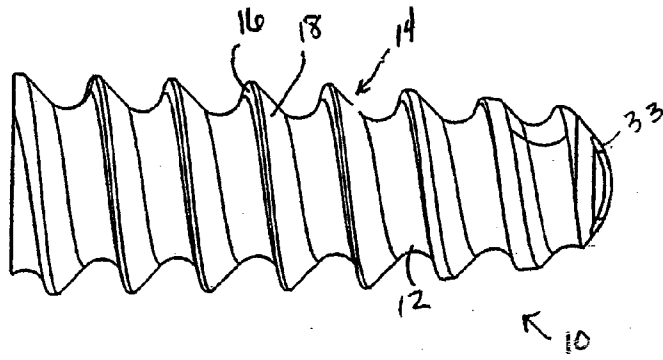

FIG. 2

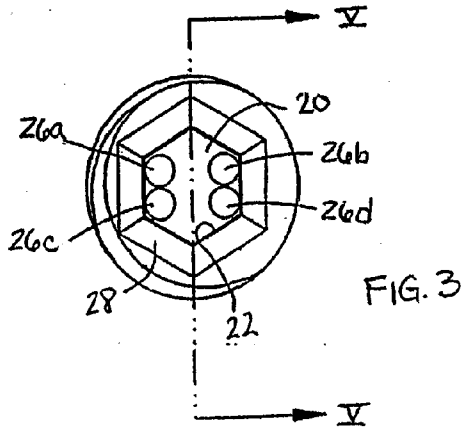

FIG. 3

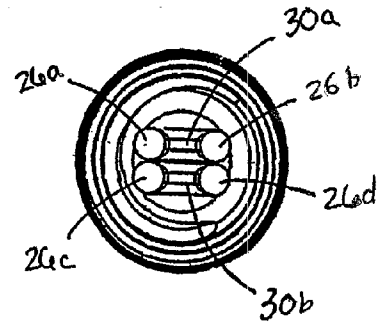
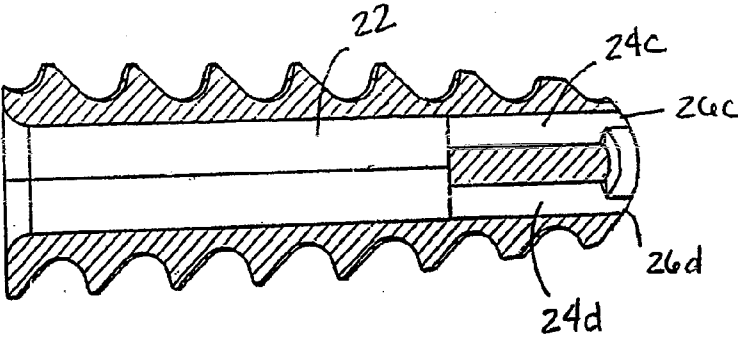
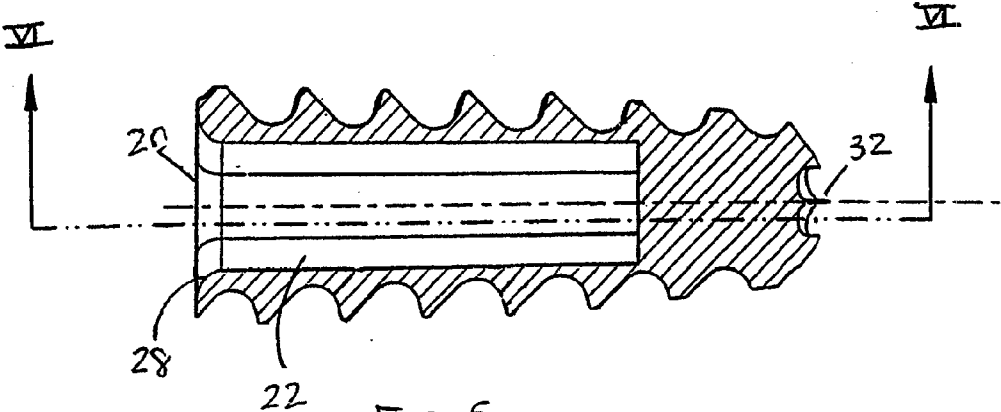

FIG. 4



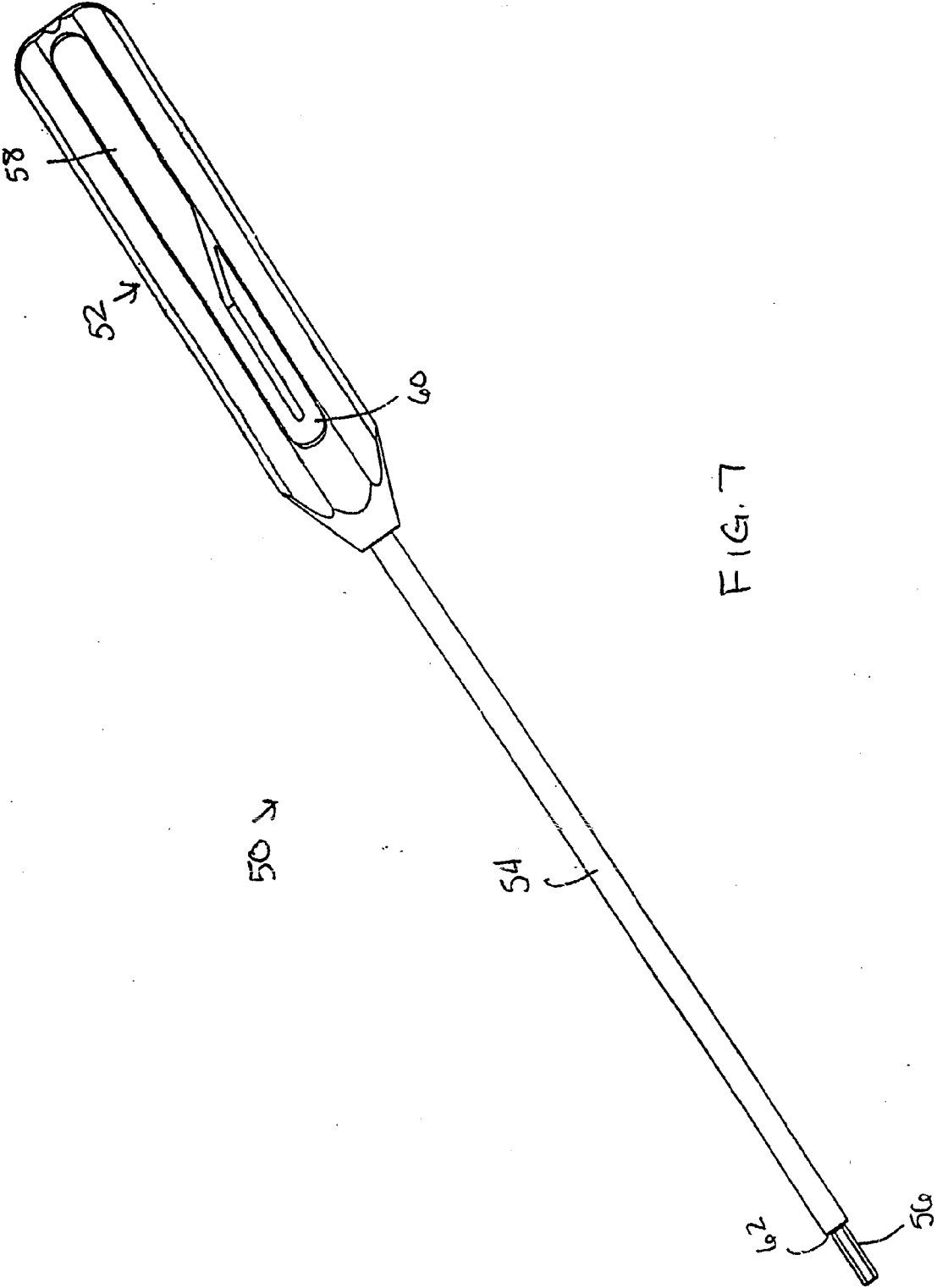

FIG. 7

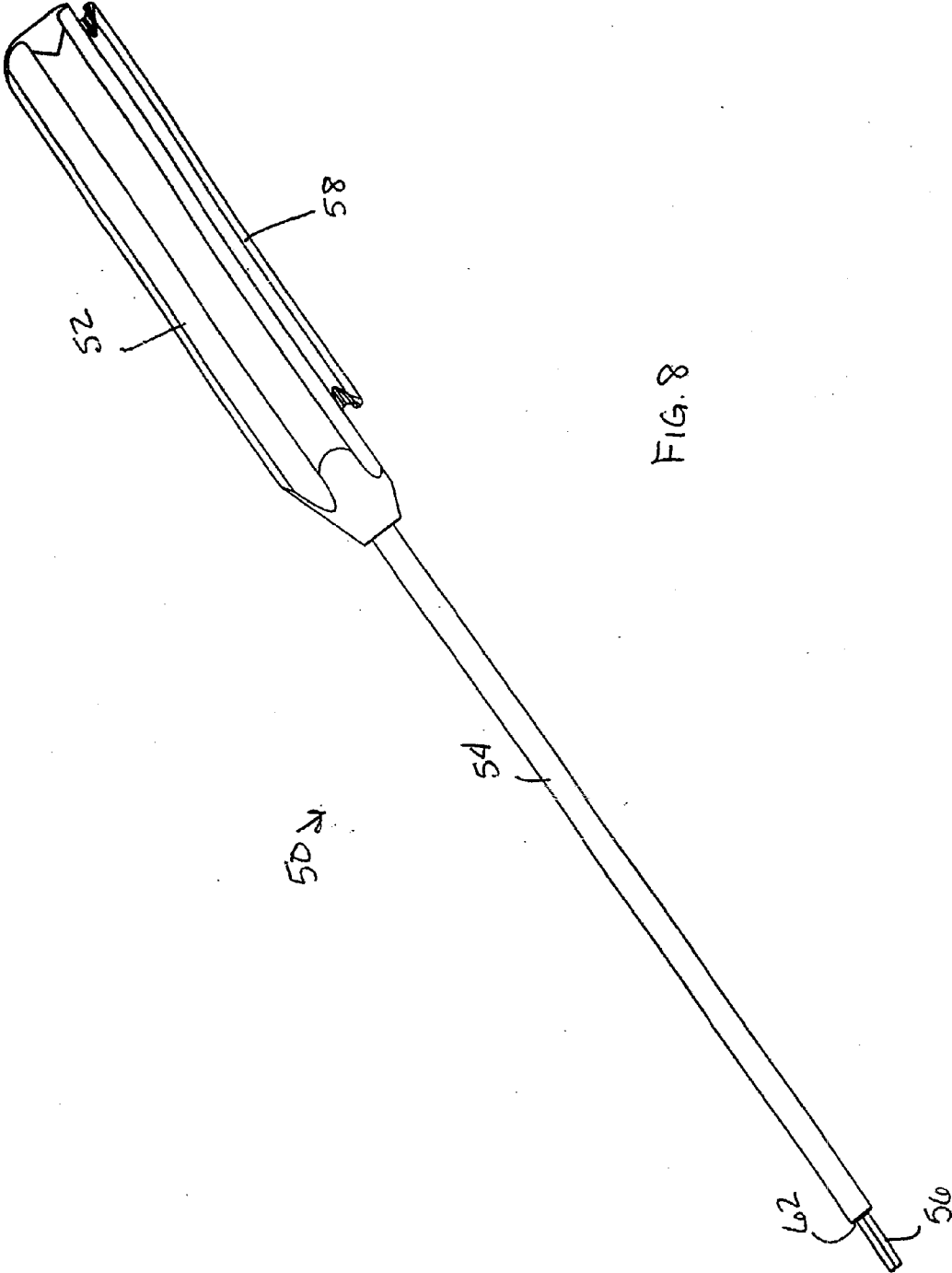

FIG. 8

SUTURE ANCHOR WITH APERTURES AT TIP

[0001] This application is a continuation of application Ser. No. 11/097,180, filed on Apr. 4, 2005, now U.S. Pat. No. 8,579,940, which claims the benefit of U.S. Provisional Application Ser. No. 60/559,426, filed Apr. 6, 2004, the entire disclosures of which are incorporated by reference herein.

BACKGROUND OF THE INVENTION

[0002] 1. Field of the Invention

[0003] The present invention relates to an apparatus for anchoring surgical suture to bone. More specifically, the present invention relates to a suture anchor having apertures at the distal tip thereof for anchoring sutures in the cortical bone during arthroscopic surgery.

[0004] 2. Description of the Related Art

[0005] When soft tissue tears away from bone, re-attachment becomes necessary. Various devices, including sutures, screws, staples, wedges, and plugs have been used in the prior art to secure soft tissue to bone.

[0006] Recently, various types of threaded suture anchors have been developed for this purpose. Some threaded suture anchors are designed to be inserted into a pre-drilled hole. Other suture anchors are self-tapping.

[0007] U.S. Pat. No. 5,156,616, for example, discloses a suture anchor which has an axial passageway extending through the suture anchor. The passageway has a proximal portion, a central portion, and a distal portion. The proximal portion is hexagonally-shaped to cooperate with a hex driver for installing the anchor. The distal portion is sized to receive a knotted piece of suture, and the central portion has a diameter less than the that of the proximal and distal portions to receive the suture being threaded therethrough. Use of the suture anchor disclosed in the '616 patent, however, requires tying a suture knot. If the knot is not tied securely or if the knot is not made large enough, there is a risk that the knot will unravel or be pulled through the distal portion of the passageway.

[0008] Another prior art suture anchor is disclosed in U.S. Pat. No. 5,370,662 and has an eyelet located on the proximal end of the anchor through which a suture can be passed. Since the eyelet is formed as part of the drive head, however, combining these two functions in one structure often tends to weaken the drive head.

[0009] Problems can arise if the structure for attaching the suture fails, allowing the suture to become detached from the anchor. For example, if the suture anchor is biodegradable, the eyelet can degrade rapidly, causing the suture to become detached from the anchor prematurely.

[0010] Further, such a prior art suture anchor having an eyelet extending from the proximal end thereof requires countersinking of the eyelet below the bone surface to avoid having the patient's tissue abrade against the exposed eyelet. As a result, suture attached to the eyelet is vulnerable to abrasion by the bony rim of the countersunk hole into which the suture anchor is installed.

[0011] In addition, various other modifications to the drive head often are employed in connection with suture attachment. For example, recessed grooves may be formed on opposite sides of the drive head to receive and protect the suture from abrasive areas of the suture anchor tunnel or to facilitate mating between the anchor to the driver. In such cases, the drive head often must be made of a larger diameter

to recover the mechanical strength lost from the removal of material relating to the suture-attachment or suture-protection modifications.

[0012] Accordingly, a need exists for a threaded suture anchor to which suture is secured effectively so as to prevent detachment of the suture. In addition, a need exists for suture anchors that will not abrade tissue and do not require countersinking.

SUMMARY OF THE INVENTION

[0013] The present invention provides a suture anchor which securely affixes sutures to the anchor without subjecting the sutures to abrasion by the surrounding bone or subjecting the tissue to be secured with the suture anchor to be abraded by the sutures. Moreover, the suture anchor according to the present invention can be installed without countersinking.

[0014] The suture anchor according to the present invention includes a threaded anchor body having a bore for receiving a driver, and at least one aperture at the distal end of the suture anchor. At least one groove is in communication with the aperture.

[0015] A suture strand can be inserted into the suture anchor and pass through the aperture, and when the ends of the sutures are pulled as far as possible out the proximal end of the suture anchor, the portion of the sutures seated in the grooves are thereby protected from abrasion during installation of the suture anchor.

[0016] Other features and advantages of the present invention will become apparent from the following description of the invention, which refers to the accompanying drawings.

BRIEF DESCRIPTION OF THE DRAWINGS

[0017] FIG. 1 is a perspective view of the suture anchor in accordance with the present invention.

[0018] FIG. 2 is a side elevational view of the suture anchor shown in FIG. 1.

[0019] FIG. 3 is a view of the proximal end of the suture anchor of the present invention.

[0020] FIG. 4 is a view of the distal end of the suture anchor of the present invention.

[0021] FIG. 5 is a cross-sectional view of the suture anchor through the plane V-V in FIG. 3.

[0022] FIG. 6 is a cross-sectional view of the suture anchor through the plane VI-VI in FIG. 5.

[0023] FIGS. 7 and 8 are side elevational views of a driver used in connection with the suture anchor of the present invention.

DETAILED DESCRIPTION OF THE PREFERRED EMBODIMENT

[0024] In the following detailed description, reference is made to various specific embodiments in which the invention may be practiced. These embodiments are described with sufficient detail to enable those skilled in the art to practice the invention, and it is to be understood that other embodiments may be employed, and that structural and logical changes may be made without departing from the spirit or scope of the present invention.

[0025] Referring first to FIGS. 1 and 2, an exemplary embodiment of the suture anchor according to the present invention is identified generally by reference numeral 10. Suture anchor 10 includes a body 12 formed generally in the

shape of a slightly tapered cylinder and having a blunt or slightly rounded distal end. In an exemplary embodiment, suture anchor **10** is provided with about eight flights of thread **14** wrapping around body **12**, with the angle of the proximal surface **16** of each thread being approximately between one-third and one-fourth the angle of the distal surface **18** of each thread relative to the horizontal. For example, in the preferred embodiment, the proximal surface of each thread has an angle of 12° relative to a plane horizontal to the axis of the suture anchor, while the distal surface of each thread has an angle of 45° relative to the same horizontal plane.

[0026] In an exemplary embodiment, body **12** of suture anchor **10** has a length of about 0.6 in. and an exterior diameter of about 0.22 in. (5.5 mm) as measured across the outer diameter of the threading at the proximal end of the anchor.

[0027] Referring now to FIGS. 3-6, suture anchor **10** is provided with a bore **22** starting from an opening **20** at the proximal end and extending into the anchor body **12** approximately two-thirds of the length therethrough. Although FIGS. 3-6 illustrate bore **22** having a hexagonal cross-section, and although references to the bore **22** will be made in this application as to the hexagonal bore **22**, the invention is not limited to this embodiment and contemplates suture anchors provided with central bores having various cross-sectional configurations. Distally of hexagonal bore **22**, anchor body **12** is solid except for four passageways (only **24c** and **24d** are seen in FIG. 6) extending to four corresponding apertures **26a-26d** on the curved surface of the distal end of suture anchor **10**.

[0028] The four apertures **26a-26d** are arranged in two pairs, i.e. **26a-26b** and **26c-26d**, with each pair defining the ends of a respective groove **30a**, **30b** formed at the distal end of suture anchor **10**. The two grooves **30a**, **30b** are parallel and recessed from a most distal surface **33** of suture anchor **10** so as to define a ridge **32** between them.

[0029] Two strands of suture can be threaded into suture anchor **10**, with the two ends of one suture strand being threaded through apertures **26a** and **26b** formed in groove **30a**, and the two ends of another suture strand being threaded through apertures **26c** and **26d** in groove **30b**. The ends of the suture strands are passed through the respective passageways **24a-24d** and the hexagonal bore **22** to exit the suture anchor **10** from the proximal opening **20**.

[0030] With sutures threaded through suture anchor **10** as described above, the view from the distal end of suture anchor **10** is similar to that of a button sewed onto an article of clothing with thread. When the sutures ends are pulled as far as possible out the proximal end of suture anchor **10**, the portions of the sutures contacting the distal end surface of suture anchor lie in the grooves **30a**, **30b** between ridge **34** and the exterior walls of the grooves, and are protected from abrasion thereby.

[0031] The apertures **26a** and **26c**, and also **26b** and **26d** can be placed close together since they are not in the same groove; hence, there will be no force exerted on suture anchor body **12** between these respective apertures. On the other hand, the greater distance between apertures **26a** and **26b**, and also **26c** and **26d** at the ends of groove **30a** and **30b**, respectively, and the solid material of body **12** forming the regions between these pairs of apertures provide the structural integrity to support the stress exerted on the suture anchor **10** by the sutures threaded therethrough. In the preferred embodiment, the centers of the pair of apertures **26a**, **26b** and **26c**, **26d** formed in each groove **30a**, **30b** are spaced approximately 0.05 to about 0.08 in., more preferably approximately 0.065

in., apart, while the centers of adjacent apertures **26a**, **26c** and **26b**, **26d** from the opposing grooves are spaced much closer, e.g. approximately 0.032 in.

[0032] The proximal surface and associated edges of suture anchor **10** defining the hexagonally shaped opening **20** is rounded and smooth. Preferably, the proximal surface of the suture anchor **10** forming the periphery of the opening **20** forms a rounded lip **28** so that opening **20** has a slightly wider diameter than the main portion of hexagonal bore **22**. Prior art anchors have sharp edges surrounding the drive opening, which are problematic in that any sutures passed through the central cannula of the anchor can be abraded by the sharp edges, thereby compromising the strength of the sutures. With the smooth and rounded proximal end provided in the anchor according to the present invention, sutures threaded through the apertures **26** will not become frayed upon pressure or rubbing against the anchor at the proximal opening.

[0033] As an alternative embodiment of the present invention, suture anchor body **12** can be provided with only two apertures **26** and one groove **30**, or can be provided with more than two pairs of apertures and a corresponding number of grooves.

[0034] Preferably, suture anchor **10** is made from a bioabsorbable polymer material such as a polyglycolic or polylactic acid polymer, poly(l-lactide-co-d, l-lactide) 70:30 (PLDLA) being most preferred. Also, it is preferred that the sutures used in connection with the inventive suture anchor are also bioabsorbable, such as No. 2 or No. 5 USP braided polyester.

[0035] Although PLDLA is the most preferred material for the suture anchor of the present invention, the suture anchor can be made from other bioabsorbable materials known in the art. As used herein, the term "bioabsorbable" is considered to be interchangeable with the term "biodegradable," "resorbable," and "absorbable" to mean that the device can be absorbed by the body over time. Also, the measurements, angles and ratios between the dimensions of the suture anchor may be varied from those described above so as to be suitable for the conditions and applications in which the suture anchor is to be used.

[0036] Optionally, the suture anchor can be distributed with at least one strand of suture already threaded through the apertures **26a-26d**.

[0037] A driver such as that shown in FIGS. 7 and 8 is used to install the suture anchor **10** of the present invention during an arthroscopic procedure. Driver **50** has a handle **52**, a shaft **54**, and a drive head **56**. Drive head **56** is hexagonally shaped and has a width and a length which substantially corresponds to the width and length of hexagonal bore **22** in suture anchor **10**. Preferably, the drive head is slightly shorter and has a slightly smaller width than bore **22**, so that the fit is not too tight, yet ensures secure engagement for driving the suture anchor into bone.

[0038] Driver **50** is cannulated throughout the length thereof, with a distal opening at the distal face of drive head **56** and a proximal opening at the proximal surface of handle **52**. Sutures threaded through suture anchor **10** from apertures **26a-26d** at the distal end thereof and exiting through the proximal opening **20** can thus be passed through the cannula through driver **50** when drive head **56** is to be engaged with bore **22** in suture anchor **10** for driving the same.

[0039] Handle **52** preferably includes an elongated double hook **52** extending substantially along the length thereof and having a hook at the proximal end and at the distal end

thereof, and a clip 60 formed at one end region of the double hook 52. When driver 50 is engaged with suture anchor 10, excess lengths of suture passed through the proximal end of driver 50 can be wrapped around the double hook 52, and the ends of the sutures can be secured in the clip 60. In this manner, the suture strands can be prevented from becoming tangled or otherwise interfering with the surgeon's work.

[0040] Driver 50 is preferably constructed to withstand an application of 20 in/lb of torque. Preferably, though not necessarily, at least the shaft 54 and drive head 56 are made of stainless steel. However, other materials may be used which provide the necessary strength and rigidity for installing the suture anchor of the present invention into cortical bone.

[0041] To install the suture anchor of the present invention, a hole is pre-formed in the bone, either with a punch or a drill. Preferably, the diameter of the hole formed is slightly (e.g. 1 mm) smaller than the diameter of the suture anchor to be installed, to ensure good purchase of the suture anchor threads in the bone.

[0042] The ends of the suture strands threaded through the suture anchor 10 are then threaded through the cannula in driver 50, and the distal end of the hexagonal drive head 56 of the driver is then inserted into the hexagonal bore 22 of the anchor 10 so that the shoulder 62 forming the transition between the drive head 56 and the drive shaft 54 abuts the lip 28 at the proximal surface of suture anchor 10. If necessary or applicable, excess lengths of the sutures exiting the proximal end of driver 50 are wrapped around the double hook 58 and/or clipped in clip 60.

[0043] The suture anchor is then placed at the opening of the prepared hole in the bone, and the driver 50 is rotated until the proximal surface of the anchor is flush with the surface of the bone. Since it is not necessary for the proximal end of the anchor to be countersunk below the bone surface to prevent tissue abrasion, as is required with prior art devices, the inventive anchor does not need to be inserted as far as prior art devices, and avoids abrasion of the sutures by the rim of the bone around the installed suture anchor.

[0044] The suture anchor of the present invention provides advantages in addition to those already discussed above. For example, with the threads provided along the entire length of the suture anchor body, the anchor is afforded maximum securement by the threads in the cortical bone, unlike some prior art anchors in which the threads only contact the cancellous bone. Also, the significant depth of the hexagonal bore for receiving the driver allows the suture anchor to be installed with a higher torque than many prior art anchors, thus imparting greater fixation strength to the installed anchor of the present invention.

[0045] Although the present invention has been described in relation to particular embodiments thereof, many other

variations and modifications and other uses will become apparent to those skilled in the art. Therefore, the present invention is to be limited not by the specific disclosure herein, but only by the appended claims.

What is claimed is:

- 1. A suture anchor comprising:
 - a threaded anchor body having a proximal end and a distal end;
 - an aperture located at the distal end of the anchor body;
 - at least one groove in communication with the aperture;
 - a suture passing through the aperture, and being seated in the at least one groove..
- 2. A method of surgery, comprising inserting a suture anchor having a threaded anchor body into a hole formed in bone, the suture anchor having an aperture located at a distal end of the anchor body, at least one groove in communication with the aperture, and a suture passing through the aperture and through the at least one groove, the suture anchor being inserted by turning the threaded suture anchor body, the portion of the suture seated in the at least one groove being protected from abrasion during installation of the suture anchor.
- 3. A suture anchor comprising:
 - an anchor body having a proximal end and a distal end;
 - a central bore extending from an opening at the proximal end of the anchor body through a portion of the length thereof;
 - a plurality of apertures in the distal end of the anchor body and in communication with the central bore, wherein the apertures define the ends of a groove extending between the apertures at the distal end of the anchor body, the groove being parallel and recessed from the distal end; and
 - a suture passing through the apertures, and through the groove.
- 4. The suture anchor according to claim 3, wherein the apertures are connected to a passageway that extends through the anchor body substantially parallel to a longitudinal axis of the anchor body.
- 5. The suture anchor according to claim 3, wherein the central bore has a hexagonal cross-sectional shape.
- 6. The suture anchor according to claim 3, wherein the central bore has a cross-sectional shape so as to accommodate a driver head for driving the suture anchor.
- 7. The suture anchor according to claim 3, wherein the anchor body comprises a plurality of thread flights extending from the outer surface of the anchor body.
- 8. The suture anchor according to claim 4, wherein the length of the passageway is about one third the length of the anchor body.

* * * * *