

(19) World Intellectual Property Organization
International Bureau



(43) International Publication Date
14 May 2010 (14.05.2010)

PCT

(10) International Publication Number
WO 2010/053673 A2

(51) International Patent Classification:
A61N 1/05 (2006.01) A61N 1/36 (2006.01)

(74) Agents: SUNSTEIN, Bruce, D. et al.; Sunstein Kann
Murphy & Timbers LLP, 125 Summer Street, Boston,
MA 02110 (US).

(21) International Application Number:
PCT/US2009/060787

(81) Designated States (unless otherwise indicated, for every
kind of national protection available): AE, AG, AL, AM,
AO, AT, AU, AZ, BA, BB, BG, BH, BR, BW, BY, BZ,
CA, CH, CL, CN, CO, CR, CU, CZ, DE, DK, DM, DO,
DZ, EC, EE, EG, ES, FI, GB, GD, GE, GH, GM, GT,
HN, HR, HU, ID, IL, IN, IS, JP, KE, KG, KM, KN, KP,
KR, KZ, LA, LC, LK, LR, LS, LT, LU, LY, MA, MD,
ME, MG, MK, MN, MW, MX, MY, MZ, NA, NG, NI,
NO, NZ, OM, PE, PG, PH, PL, PT, RO, RS, RU, SC, SD,
SE, SG, SK, SL, SM, ST, SV, SY, TJ, TM, TN, TR, TT,
TZ, UA, UG, US, UZ, VC, VN, ZA, ZM, ZW.

(22) International Filing Date:
15 October 2009 (15.10.2009)

(25) Filing Language: English

(26) Publication Language: English

(30) Priority Data:
61/105,493 15 October 2008 (15.10.2008) US

(71) Applicant (for all designated States except US): MED-
EL ELEKTROMEDIZINISCHE GERAETE GMBH
[AT/US]; Fuerstenweg 77a, A-6020 Innsbruck (AT).

(84) Designated States (unless otherwise indicated, for every
kind of regional protection available): ARIPO (BW, GH,
GM, KE, LS, MW, MZ, NA, SD, SL, SZ, TZ, UG, ZM,
ZW), Eurasian (AM, AZ, BY, KG, KZ, MD, RU, TJ,
TM), European (AT, BE, BG, CH, CY, CZ, DE, DK, EE,
ES, FI, FR, GB, GR, HR, HU, IE, IS, IT, LT, LU, LV,
MC, MK, MT, NL, NO, PL, PT, RO, SE, SI, SK, SM,

(72) Inventors; and
(75) Inventors/Applicants (for US only): JOLLY, Claude
[FR/AT]; K Innerebner St. 95a C4, A-6020 Innsbruck
(AT). SIEBER, Daniel [DE/AT]; Schneeberggasse 37,
A-6020 Innsbruck (AT).

[Continued on next page]

(54) Title: IMPLANT ELECTRODE AND ACCESSORIES FOR USE IN ROBOTIC SURGERY

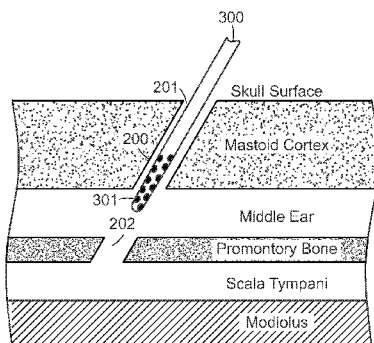

FIG. 3A

(57) Abstract: An implant electrode for a cochlear implant system includes a basal electrode lead passing from an implant housing to a mastoid cortex surface for carrying one or more electrical stimulation signals from the implant housing. An apical electrode array fits through a cochleostomy opening into a cochlea scala and has multiple electrode contacts for applying the electrical stimulation signals to target neural tissue. A middle electrode section passes through the mastoid cortex and the middle ear to the cochleostomy opening for connecting the electrode lead and the electrode array.

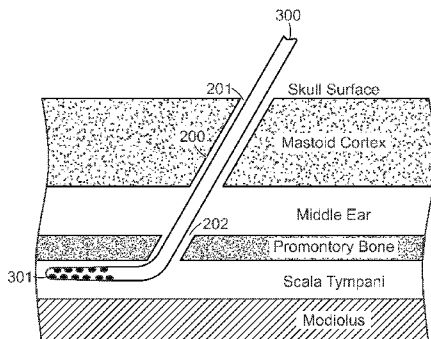

FIG. 3B

WO 2010/053673 A2

TR), OAPI (BF, BJ, CF, CG, CI, CM, GA, GN, GQ, GW, ML, MR, NE, SN, TD, TG). **Published:**

— *without international search report and to be republished upon receipt of that report (Rule 48.2(g))*

TITLE

Implant Electrode and Accessories for Use in Robotic Surgery

[0001] This application claims priority from U.S. Provisional Patent Application 61/105,493, filed October 15, 2008, which is incorporated herein by reference.

FIELD OF THE INVENTION

[0002] The present invention relates to medical implants, and more specifically to an implant electrode and accessories for use in cochlear implant systems.

BACKGROUND ART

[0003] Audio prosthesis electrodes such as cochlear implant electrodes are intended to be manually inserted into the inner ear cavity that will receive them. Usually cochlear implant electrodes are made of a somewhat soft silicone material which receives and protects the wires that connect to electrode contacts on the surface of the apical end of the electrode. There may also be a stylet to hold a pre-shaped electrode array section straight during insertion.

[0004] As used herein, the term “electrode array” refers to the apical end section of the implant electrode that penetrates into the cochlea scala of the inner ear. An electrode array has multiple electrode contacts on or slightly recessed below its outer surface for applying one or more electrical stimulation signals to target audio neural tissue. An “electrode lead” refers to the basal portion of the implant electrode that goes from the implant housing to the electrode array. It usually has no contact except perhaps a ground electrode and it encloses connecting wires delivering the electrical stimulation signals to the electrode contacts on the electrode array. The term “electrode” refers to the entire implant electrode from end to end, that is, the combination of the electrode array and the electrode lead.

SUMMARY OF THE INVENTION

[0005] An implantable electrode for a cochlear implant system includes a basal electrode lead passing from an implant housing to a mastoid cortex surface for carrying one or more electrical stimulation signals from the implant housing. An apical electrode array fits

through a cochleostomy opening into a cochlea scala and has multiple electrode contacts for applying the electrical stimulation signals to target neural tissue. A middle electrode section passes through the mastoid cortex and the middle ear to the cochleostomy opening for connecting the electrode lead and the electrode array.

[0006] The middle electrode section may be straight or curved, and may be subdivided into a middle ear section and a mastoid section. The middle electrode element may include an outer tube support that provides structural stiffening, for example, based on at least one of a metallic, polymer, and textile material. Or the middle electrode element may include an inner core support such as a rod that provides structural stiffening, which may be based on at least one of a metallic, polymer, and textile material. The middle electrode section may have a larger diameter than the electrode lead and the electrode array. The middle electrode section may be rigid, and the electrode lead and the electrode array may be flexible. Or the electrode array may be rigid for direct insertion into the modiolus.

[0007] In some embodiments, the electrode lead may include one or more positioning knobs for moving the electrode into or out of the mastoid cortex surface. The electrode array may have a pre-shaped curve to fit into the cochlea, which may be activated by fluid heat, fluid hydration, or by release from a holding tube when inserted in the cochlea.

[0008] Embodiments of the present invention are also directed to a guide for inserting a cochlear implant electrode array having electrode contacts into a cochlea scala. An elongated guide member defines a passage for a section of a stimulation electrode from a mastoid cortex surface to a cochleostomy opening into a cochlea scala for insertion of the electrode array through the cochleostomy opening into the cochlea scala.

[0009] The guide member may include an interior volume through which the electrode array passes when inserted into the cochlea scala. The guide member may include a grooved channel that contains the section of the stimulation electrode. The guide member may form a stent, a tapered tube, a funnel shape, or be collapsible for insertion into the passage and then open like an umbrella. The guide member may be made of a mesh material. It may be rigid and/or removable. The guide member may be metallic, polymer

or fabric, and may be straight or elbow shaped to turn the electrode array into the curve of the cochlea.

[0010] In some embodiments, the guide member may be externally lubricated to reduce friction when inserted or extracted, and/or internally lubricated to reduce friction when the electrode array slides through it. The guide member may have openings on its outer surface. It may include a stopper tip to prevent insertion of the guide member into the cochlea scala. There also may be positioning marks for use when inserting the guide member. There may be bifurcated sections to facilitate removal of the guide member from the passage after insertion of the electrode array in the cochlea scala. The guide member may include concentric coaxial tubes, which may have openings on their surfaces.

[0011] The guide member may be permanently implantable, for example, it may be biologically resorbable after insertion. The electrode array may be based on a thin film electrode. The guide member may include a detachable tip.

[0012] Embodiments of the present invention are also directed to a method of inserting a stimulation electrode for a cochlear implant system. A passage is drilled through a mastoid cortex surface and a cochlear promontory surface into a cochlea scala. Then an electrode array having electrode contacts is inserted through the passage into the cochlea scala.

[0013] The inserting may be performed robotically. The passage may have a larger diameter through the mastoid cortex and a smaller diameter through the cochlear promontory. Inserting an electrode array may include inserting an electrode guide that encloses a portion of the stimulation electrode.

BRIEF DESCRIPTION OF THE DRAWINGS

[0014] Figure 1 shows a cross-section of the skull bone structure near the cochlea.

[0015] Figure 2 shows an example of a passage through a portion of the skull bone to the cochlea according to one embodiment of the present invention.

[0016] Figure 3A-B shows introduction of an electrode array through the mastoid cortex into the cochlea scala according to an embodiment of the present invention.

[0017] Figure 4A shows a stimulation electrode according to one embodiment of the present invention.

[0018] Figure 4B shows use of an electrode guide for introduction of an electrode array through the mastoid cortex.

[0019] Figure 4C shows a implant electrode and electrode guide according to an embodiment.

[0020] Figure 4D shows another embodiment of a stimulation electrode according to the invention.

[0021] Figure 5A-B shows electrode guides according to various embodiments of the present invention.

[0022] Figure 6 shows a coaxial tube structure electrode guide.

[0023] Figure 7 shows an electrode guide having a stopper structure.

[0024] Figure 8 shows an elbow shaped electrode guide.

[0025] Figure 9 shows another elbow shaped electrode guide.

[0026] Figure 10 shows funnel shaped electrode guide.

[0027] Figure 11 shows a guide tip for an electrode guide.

[0028] Figure 12 shows various logical steps in one embodiment.

DETAILED DESCRIPTION OF SPECIFIC EMBODIMENTS

[0029] Robotic surgery is being developed based on direct linear access from the skull surface to an inner ear opening. There is a need to adapt the implant electrode for either a non-manual insertion and/or an insertion through a robotically drilled narrow hole.

Embodiments of the present invention are directed to an implant electrode that can be inserted into the cochlea through an electrode passage directly from the mastoid cortex through the middle ear and promontory bone into the cochlea scala, accessories for such inserting such an electrode, and the passage creation and electrode insertion processes.

[0030] Figure 1 shows a cross-section of the skull bone structure near the cochlea with the skin removed. In order, the skull surface is the outer surface of the mastoid cortex bone, beneath which is the volume of the middle ear. The outer surface of the cochlea is at the promontory bone which encloses the interior scalae of the cochlea such as the scala tympani, which lies over the inner modiolus bone. During robotic surgery, to access the cochlea with a stimulation electrode, a narrow electrode passage **200** is drilled as shown in Figure 2 through the mastoid cortex and to directly access the promontory bone, where a cochleostomy can be remotely drilled to access the scala tympani. As shown in Figure 3 A-B, the implant electrode **300** with an electrode array **301** at its apical end, is inserted into the narrow opening **201** at the skull surface into the electrode passage **200**, where it can be directed through the middle ear cavity, lined up with the cochleostomy **202** (or with the round window), and then pushed into the scala tympani without visual observation. Additional features can be incorporated into the implant electrode **300** to maneuver it past obstacles, for example, by rotating and/or pulling back.

[0031] In the example shown in Figs. 2 and 3, the electrode passage **200** is inclined at an acute angle to help the implant electrode **300** follow the cochlea scala as it is pushed in. If the electrode passage **201** is more perpendicular with respect to the scala, then the implant electrode **300** may collapse against the modiolus as it is inserted into the scala. Therefore, it is preferred that the angle of the electrode passage **200** be acute enough so that when the electrode array **301** is inserted into the scala it should follow the axial direction of the scala.

[0032] The ability to directly non-visually insert an implant electrode **300** through a pre-drilled electrode passage **200** into the cochlea scala allows major time savings during cochlear implant surgery and therefore potentially reduces the risk of operation complications and improves patient recovery. The implant electrode **300** can be inserted from relatively far away from the cochleostomy **202** by pushing it from the external aperture of the mastoid cortex opening **201**. Forces are transmitted all the way to the distal tip of the electrode array **301** and insertion proceeds. An implant electrode **300** of this type is useful during robotic surgery that bypasses the prior technique of a mastoidectomy and posterior tympanotomy. The implant electrode **300** does not collapse in the middle ear if it is enclosed by a rigid detachable electrode guide. The electrode guide allows the tip of the electrode array **301** to easily line up with the cochleostomy **202**. Another useful accessory is a stent-like mesh that is deployed to allow the implant electrode **300** to take the correct direction and orientation toward the longitudinal axis of the scala.

[0033] Figure 4A shows one example of a complete implant electrode **400** according to one specific embodiment, which is attached to an implant housing **401** which processes the electrical stimulation signals to be applied by the implant electrode **400** to target audio neural tissue. A basal electrode lead **402** section passes from the implant housing **401** to the surface opening of the mastoid cortex surface. An apical electrode array **403** section fits through the cochleostomy opening in the promontory bone into a cochlea scala and has multiple electrode contacts for applying the electrical stimulation signals to target neural tissue. In specific embodiments, the electrode array **403** and its electrode contacts may be similar to what has been used before. In some embodiments, the tip of the electrode array **403** may have a pre-shaped curve to accommodate a sharp turn when it enters the scala through the cochleostomy. The pre-shaped curve may be activated in various ways such as by heat or hydration from the scala fluid, or by simple release from the electrode guide.

[0034] A middle electrode section is subdivided into a mastoid section **404** which passes through the mastoid cortex, and a middle ear section **405** which passes through the middle ear to the cochleostomy opening for connecting the electrode lead **402** and the electrode array **403**. In the embodiment shown in Fig. 4A, the mastoid section **404** and the middle ear section **405** are stiff and rigid to allow the electrode array **403** to be pushed through the

electrode passage. The stiffness allows the implant electrode **400** to be easily rotated because rotational movement is transmitted from the surface of the skull section several centimeters down to the apical end of the electrode array **403** thereby allowing maneuverability so as to overcome any obstacle it may encounter such as a curvature, a blockage, a basilar membrane, or a modiolus curvature where the electrode array **403** could get stuck. Depending on the specific circumstances, the electrode array **403** may be normally flexible for insertion into the cochlea scala, or it may also be stiff for use as a penetrating electrode arrangement to stimulate target neural tissue within the modiolus. Penetrating electrodes are described more fully in U.S. Provisional Patent Application 61/097,343, filed September 16, 2008, which is hereby incorporated by reference. The electrode lead **402** needs normal flexibility to allow good placement of the implant housing **401** on the skull bone to wind back any excess electrode lead; for example, into a hole specially drilled on the skull for this purpose. The embodiment shown in Fig. 4A also includes positioning knobs **408** for pushing the implant electrode **400** into or pulling it out of the opening in the mastoid cortex.

[0035] There are several specific ways to achieve the desired degree of stiffness in the middle electrode section. Either or both of the mastoid section **404** and the middle ear section **405** can be fabricated from a stiffer polymer material than the highly flexible silicone typically used for implant electrodes—for example, a stiff polymer may be used, such as metallic, polymer or textile tubing, a stiffener core, a rod embedded in silicone, and/or anchors or some combination thereof. Figure 4D shows that the stiff middle electrode section of the mastoid section **404** and the middle ear section **405** may have a larger diameter to be more rigid than the smaller diameter and more flexible electrode array **403** and electrode lead **402**. In addition or alternatively, a permanent stiffening feature **407** such as an internal stiffening rod may be incorporated into one or more sections of the implant electrode **400**.

[0036] There may also be one or more removable stiffening features such as an electrode guide **406** shown in Fig. 4A and 4B made of metal, polymer, or fabric. The rigid electrode guide **406** in the form of a tapered open channel defines and provides rigid continuity for the electrode passage **200** from the narrow opening **201** in the skull surface, through the

mastoid cortex and middle ear to the cochleostomy opening **202**. This provides stability so that the electrode array **403** can be safely and easily inserted into the desired location in the cochlea scala. In specific embodiments, the outer surface of the electrode guide **406** may be externally lubricated to reduce friction when inserted or extracted. The electrode guide **406** may also be internally lubricated to reduce friction when the electrode **400** slides through it.

[0037] Enclosed within the electrode guide **406** are the middle electrode section **404** and **405** and the electrode array **403**, the latter of which is inserted through the cochleostomy opening in the promontory bone into the cochlea scala. The channel opening in the electrode guide **406** does not allow the rigid and larger diameter middle electrode section to come out, but does allow the smaller diameter basal portion of the electrode lead on the skull to easily come out, making it easy to remove the electrode guide **406** once the electrode array has been inserted into the cochlea scala. The electrode guide **406** is removed simply by pulling it back out of the mastoid opening while holding the thinner part of the electrode lead at some angle as shown on Figure 4C. The electrode guide **406** should be fairly rigid, tapered, and adapted to be pulled back through the opening **201** in the mastoid cortex and disconnected from the electrode lead **400**. Removal of the electrode guide may be aided by use of an array slot **506** as shown in the detail at the bottom of Figure 5B. Alternatively, the electrode guide **406** may be designed and manufactured from a bio-resorbable material.

[0038] Figure 5A shows an embodiment of simple rigid tube-shaped electrode guide **500** having an elongated tubular section **502** that encloses the middle section of the electrode and the electrode array. A flange opening **501** fits over the opening in the mastoid cortex. Hole openings **503** in the outer surface of the tubular guide member **502** facilitate regrowth of the surrounding tissue and anchors the tubular guide member **502** in a fixed position, as well as allowing extra-cellular fluid to circulate and irrigate the interior volume to avoid developing infections. In some embodiments, there may usefully be a stopper tip **505** structure as shown in Fig. 5B which prevents insertion of the guide member beyond the cochleostomy opening and into the cochlea scala. In the event that the implant electrode needs to be removed, the electrode guide **500** can be left permanently

implanted in the patient and a new electrode inserted through it. Additionally the electrode guide **500** can be marked with a scalar markings to facilitate use of information from pre-operative imaging during insertion.

[0039] Figure 6 shows an electrode guide **600** having a coaxial double tube arrangement where an inner tube **602** and an outer tube **601** are fitted together. Both or either of the inner tube **602** and outer tube **601** may be perforated by a series of hole openings **603**, which allow tissue regrowth to occur and thereby anchor the electrode guide **600** in a fixed position, as well as allow extra-cellular fluid to circulate and irrigate the inner tube **602** and thereby preventing infections from developing. All or part of the electrode guide **600** may be in the form of a mesh and deployed as a stent. Instead of hole openings **603**, some embodiments may have or open slots or may be mesh-like.

[0040] Figure 7 shows a variation of a double tube electrode guide **700** having a stopper bar **704** near the opening in the mastoid cortex. A slot **705** on the inner tube **703** allows removal of the guide from the implant electrode as it is being pulled back.

[0041] Embodiments of the present invention also include an electrode guide accessory for placement in the cochleostomy opening for guiding the electrode array into the cochlea scala. Such an electrode guide is shown in Figure 8 where a stent-type mesh cochleostomy guide **800** has an elbow-shaped curve to direct the electrode array towards the long axis of the cochlea scala as desired. Figure 8B shows a variation of a cochleostomy guide **800** in the same elbow-shape with a smooth outer surface. Because of the elbow shape, pushing down and in on the outer portion of an implant electrode is translated in direction so that the distal end of the electrode array enters the cochlea scala as shown along its directional axis. In some embodiments, the cochleostomy guide **800** may be deployable from within an electrode guide that is inserted into the electrode passage—e.g., like a collapsed umbrella shape that opens when in position. The cochleostomy guide **800** may be made of polymer, metal (e.g., nitinol), or fabric. In specific embodiments, the cochleostomy guide **800** may be removable or may be permanently implantable, e.g., by being bio-resorbable. Figure 9A shows an alternative cochleostomy guide **900** in the form of a distal tip section for an entire electrode guide as described above, which may or may not be detachable.

Figure 9B shows an alternative embodiment of a cochleostomy guide **900** having a slot on top for easy removal after insertion of the electrode array.

[0042] Figure 10 shows an embodiment a funnel-shaped cochleostomy guide **1000** that can be deployed in the middle ear to facilitate aligning the implant electrode with the cochleostomy opening. The funnel-shaped cochleostomy guide **1000** may be a mesh-type structure, e.g., a super-elastic nitinol, and during insertion in the mastoid hole, it is collapsible opens in the middle ear like an umbrella once it is inserted. The funnel-shaped cochleostomy guide **1000** may be in the form of a distal tip section for an entire electrode guide as described above, which may or may not be detachable.

[0043] Figure 11 shows yet another arrangement of an electrode guide **1100** where the implant electrode **1101** is bifurcated near the skull as shown. The bifurcated form allows a slot or notch **1102** in the electrode guide **1100** to be used to remove it from the implant electrode **1101** with minimum disturbance.

[0044] Embodiments of the present invention also include methods to insert an implant electrode (or drug delivery catheter) directly through an electrode passage in the skull. In some embodiments, this may be performed robotically and may not even require visual observation of the process. Figure 12 shows various logical steps in one embodiment of such a method where initially, a passage is drilled through the mastoid cortex to the middle ear, step **1201**. This mastoid passage should be slightly larger in diameter than the combined diameter of the electrode guide and implant electrode. The site and direction of the mastoid passage is determined based on pre-operative scans and markers, using standard techniques. Then the drill is removed, step **1202**, and the drill bit changed to a smaller size which is slightly larger in diameter than the electrode array, step **1203**. The drill is reinserted in the mastoid cortex opening, step **1204**, possibly using a drill guide such as a catheter tube that fits in the mastoid passage. The cochleostomy opening in the promontory bone is then drilled, step **1205**. The drill is removed, step **1206**, and the electrode guide containing the implant electrode is inserted into the mastoid opening, step **1207** and pushed into the mastoid passage until resistance is met. At that point, the electrode guide is held in place while the implant electrode is blindly pushed into the

scala, step **1208**. Once the electrode array is fully inserted, the electrode guide is pulled back or removed, step **1209**.

[0045] Typically, the opening in the mastoid cortex and the mastoid passage may be larger than the cochleostomy opening. It may be helpful to have a feature to accommodate this change in size to allow correct alignment of the axis of the electrode array with the center of the cochleostomy when inserted. This may also be needed when using the smaller diameter drill bit to form the cochleostomy opening—the drill bit needs to be centered in the mastoid passage.

[0046] In an alternative embodiment, the diameter of the mastoid cortex may be kept as small as possible to avoid sensitive structures (such as the facial nerve tissue and chorda tympani nerve tissue) when drilling through to the middle ear and then the cochleostomy. A thin film electrode can then be inserted in the electrode guide and into the cochlea scala. In another example, another step may be added to deploy a stent-like mesh curved guide in the cochleostomy, to better direct the electrode along the long axis of the scala.

[0047] It is understood that lubricants, lubricious coating, anti inflammatory coating, may be used in combination with the device and accessories described here. It is also understood that the implant electrode, drug delivery catheter, and the various accessories may be beneficial if using some type of endoral surgical approach, canal wall drill out, etc.

[0048] Although various exemplary embodiments of the invention have been disclosed, it should be apparent to those skilled in the art that various changes and modifications can be made which will achieve some of the advantages of the invention without departing from the true scope of the invention.

CLAIMS

What is claimed is:

1. A implantable electrode for a cochlear implant system comprising:
a basal electrode lead to pass from an implant housing to a mastoid cortex surface for carrying one or more electrical stimulation signals from the implant housing;
an apical electrode array to fit through a cochleostomy opening into a cochlea scala and having a plurality of electrode contacts for applying the electrical stimulation signals to target neural tissue; and
a middle electrode section to pass through the mastoid cortex and the middle ear to the cochleostomy opening for connecting the electrode lead and the electrode array.
2. A implant electrode according to claim 1, wherein the middle electrode element includes an outer tube support that provides structural stiffening.
3. A implant electrode according to claim 1, wherein the middle electrode element includes an inner core support that provides structural stiffening.
4. A implant electrode according to claim 1, wherein the middle electrode section has a larger diameter than the electrode lead and the electrode array.
5. A implant electrode according to claim 1, wherein the electrode lead includes one or more positioning knobs for moving the electrode into or out of the mastoid cortex surface.
6. A implant electrode according to claim 1, wherein the middle electrode section is rigid.
7. A implant electrode according to claim 1, wherein the electrode array is rigid for direct insertion into the modiolus.
8. An electrode guide for inserting a cochlear implant electrode array into a cochlea scala, the guide comprising:
an elongated guide member defining an insertion passage from a mastoid cortex

surface to a cochleostomy opening into a cochlea scala for insertion of the electrode array through the insertion passage into the cochlea scala.

9. An electrode guide according to claim 8, wherein the guide member includes an interior volume through which the electrode array passes when inserted into the cochlea scala.
10. An electrode guide according to claim 8, wherein the guide member includes a grooved channel through which the electrode array passes when inserted into the cochlea scala.
11. An electrode guide according to claim 8, wherein the guide member forms a tapered tube.
12. An electrode guide according to claim 8, wherein the guide member forms a funnel shape.
13. An electrode guide according to claim 12, wherein the guide member is collapsible for insertion into the passage and then opens like an umbrella
14. An electrode guide according to claim 8, wherein the guide member is made of a mesh material.
15. An electrode guide according to claim 8, wherein the guide member forms a stent.
16. An electrode guide according to claim 8, wherein the guide member is removable.
17. An electrode guide according to claim 8, wherein the guide member is rigid..
18. An electrode guide according to claim 8, wherein the guide member is elbow shaped to turn the electrode array into the curve of the cochlea.
19. An electrode guide according to claim 8, wherein the guide member is internally

lubricated to reduce friction when the electrode array slides through it.

20. An electrode guide according to claim 8, wherein the guide member includes openings on its outer surface.

21. An electrode guide according to claim 8, wherein the guide member includes a stopper tip to prevent insertion of the guide member into the cochlea scala.

22. An electrode guide according to claim 8, wherein the guide member includes positioning marks for use when inserting the guide member.

23. An electrode guide according to claim 8, wherein the guide member has bifurcated sections to facilitate removal of the guide member from the passage after insertion of the electrode array in the cochlea scala.

24. An electrode guide according to claim 8, wherein the guide member includes a plurality of concentric coaxial tubes.

25. An electrode guide according to claim 24, wherein the tubes have a plurality of openings on their surfaces.

26. An electrode guide according to claim 8, wherein the guide member is permanently implantable

27. An electrode guide according to claim 8, wherein the guide member is biologically resorbable after insertion.

28. An electrode guide according to claim 8, wherein the electrode array is based on a thin film electrode.

29. An electrode guide according to claim 8, wherein the guide member includes a detachable tip.

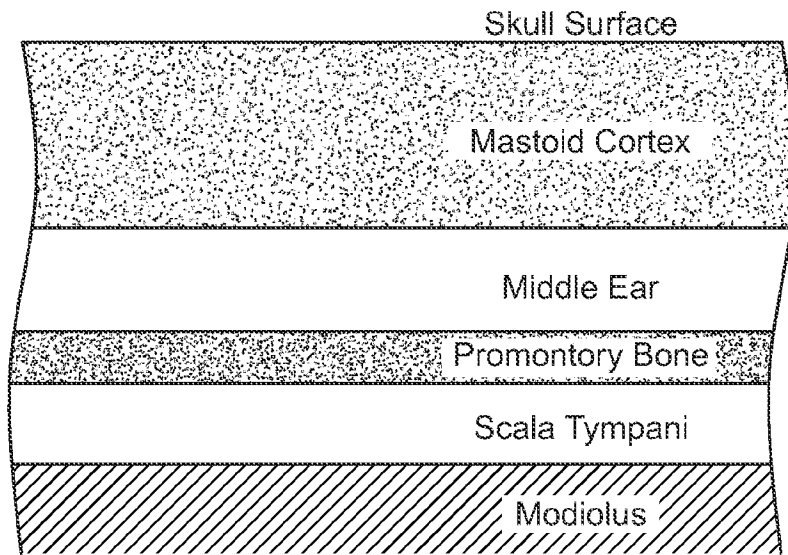

FIG. 1

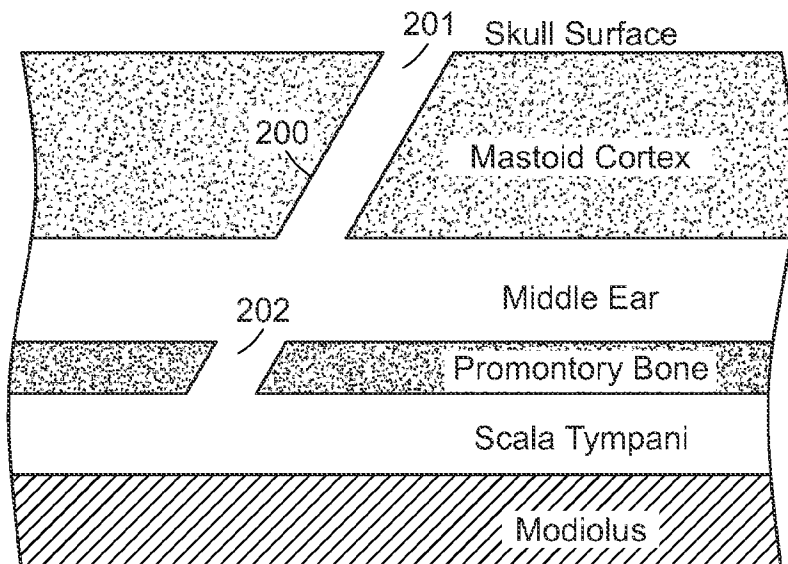

FIG. 2

2/8

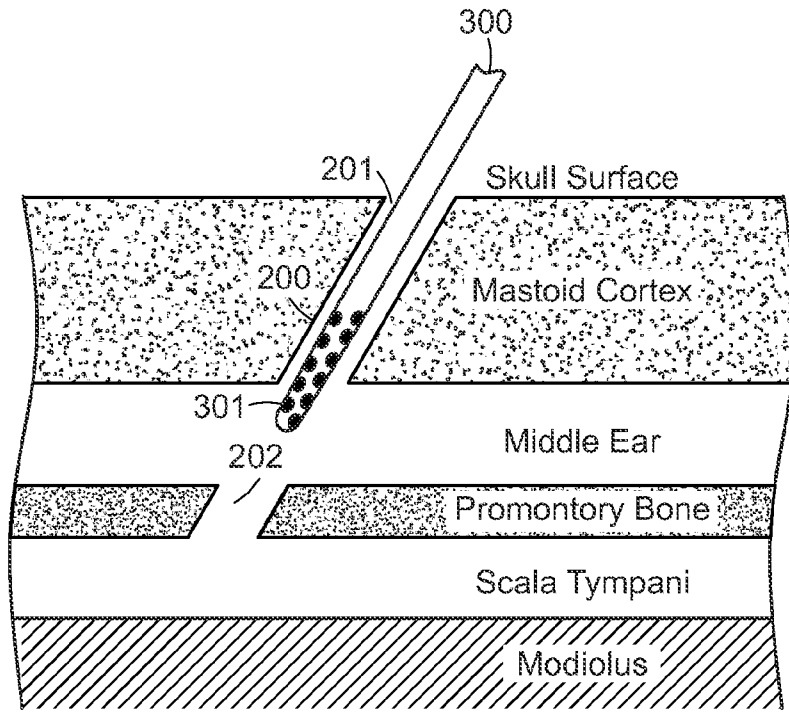

FIG. 3A

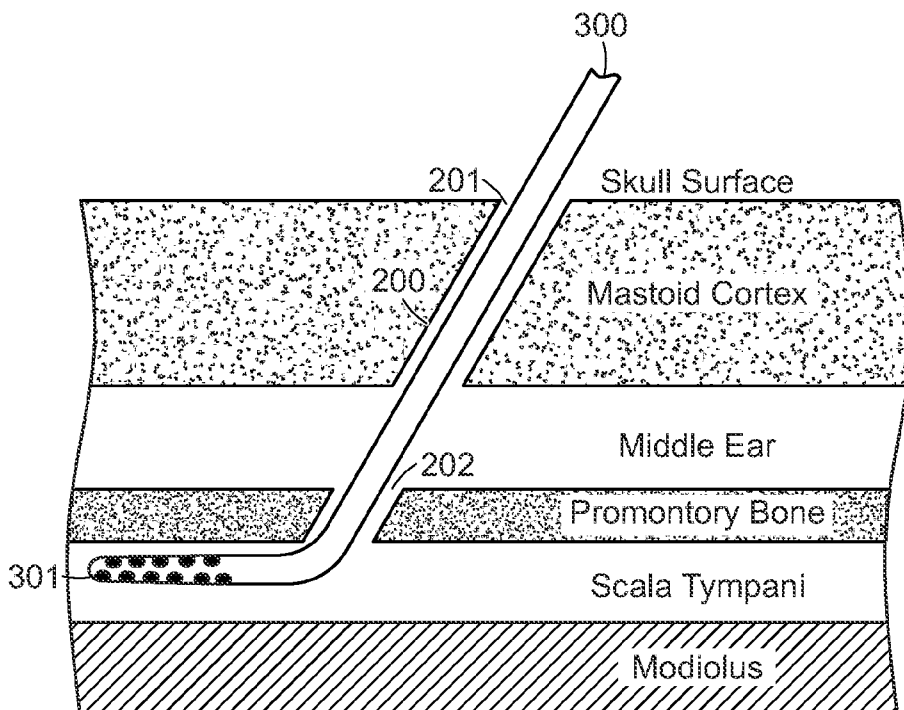

FIG. 3B

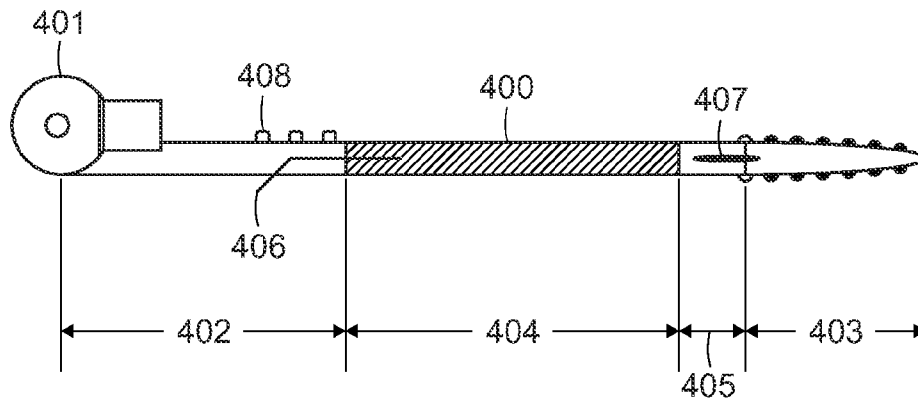

FIG. 4A

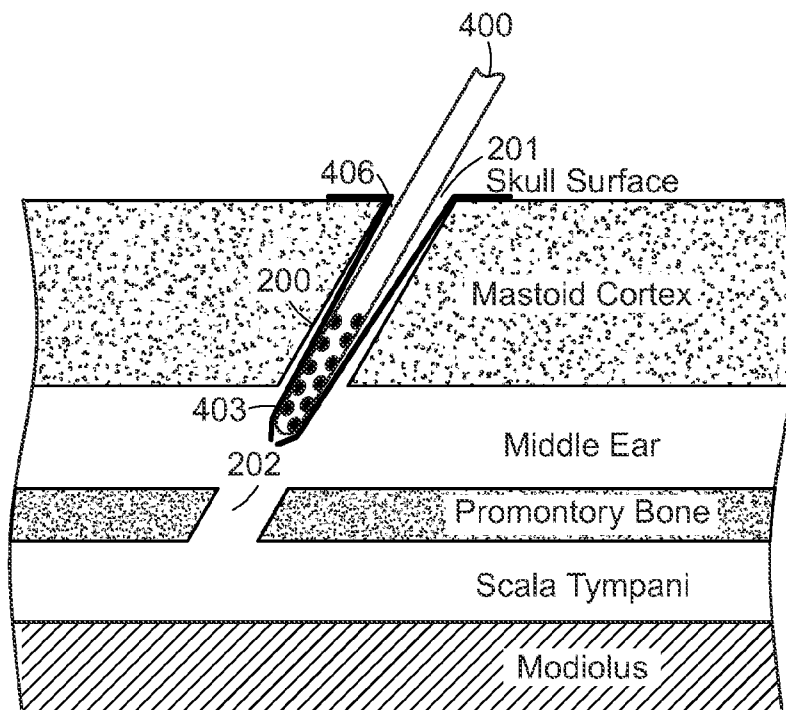

FIG. 4B

5/8

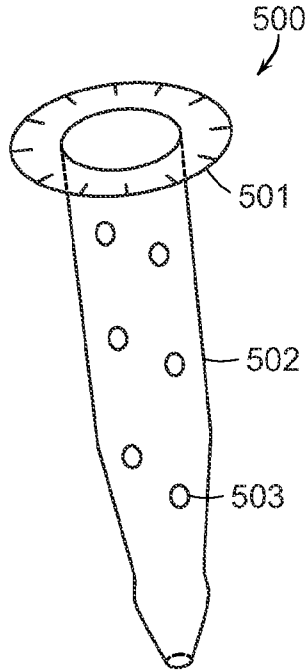

FIG. 5A

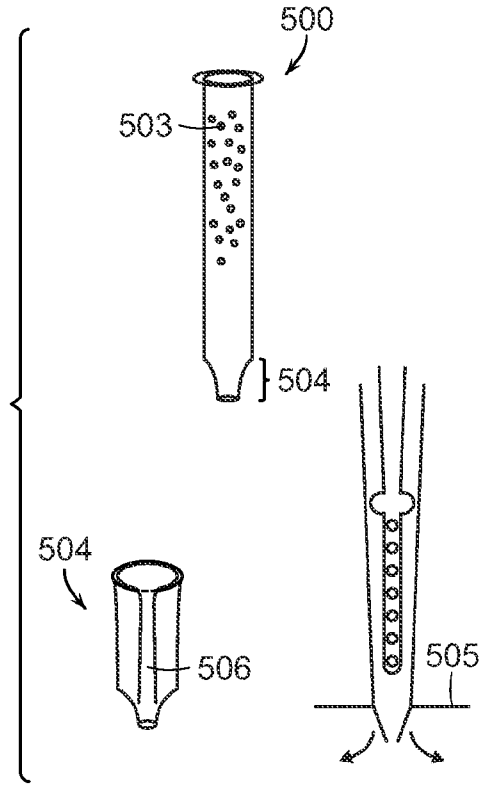

FIG. 5B

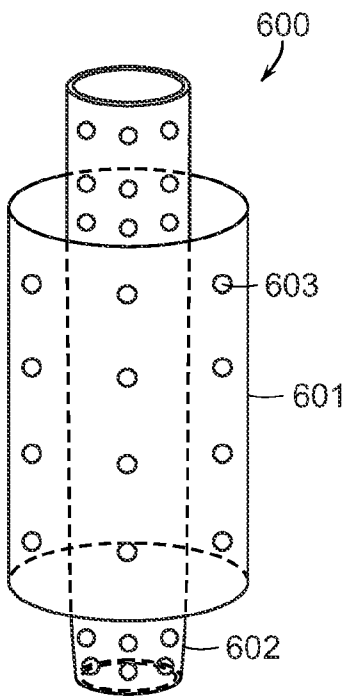

FIG. 6

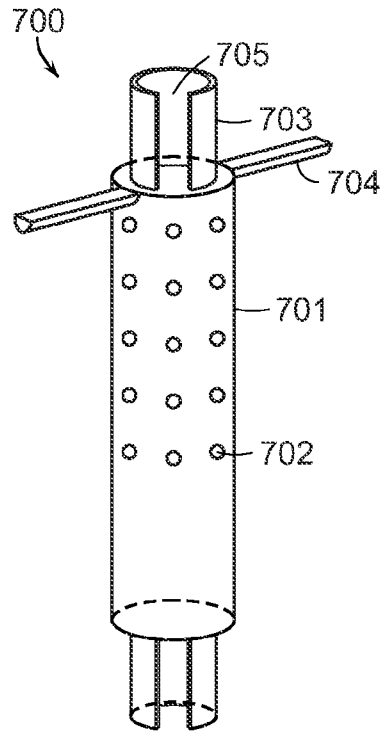

FIG. 7

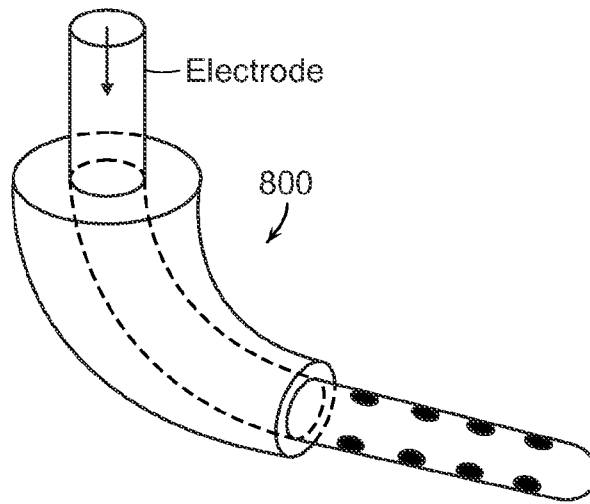

FIG. 8A

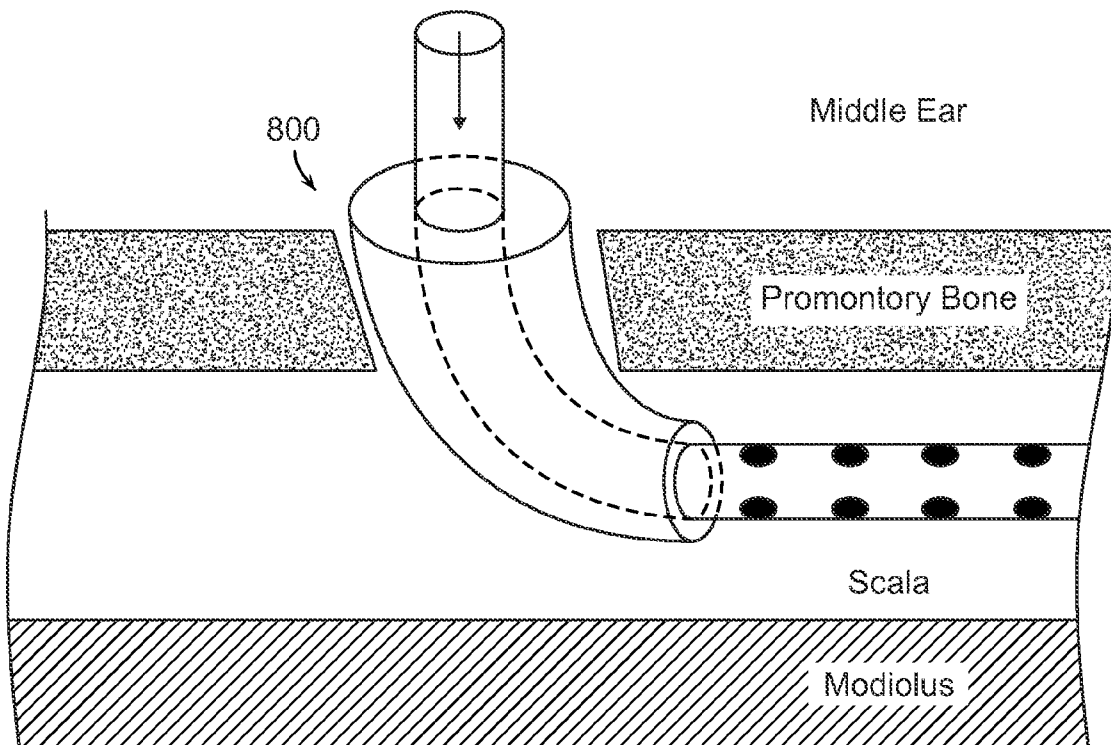

FIG. 8B



FIG. 9A

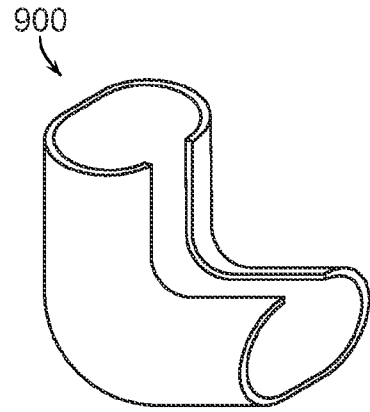

FIG. 9B

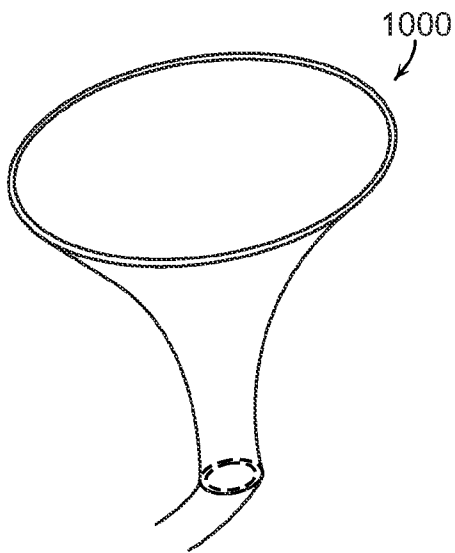

FIG. 10

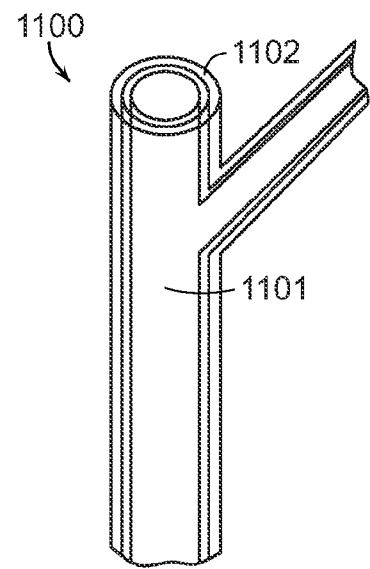

FIG. 11

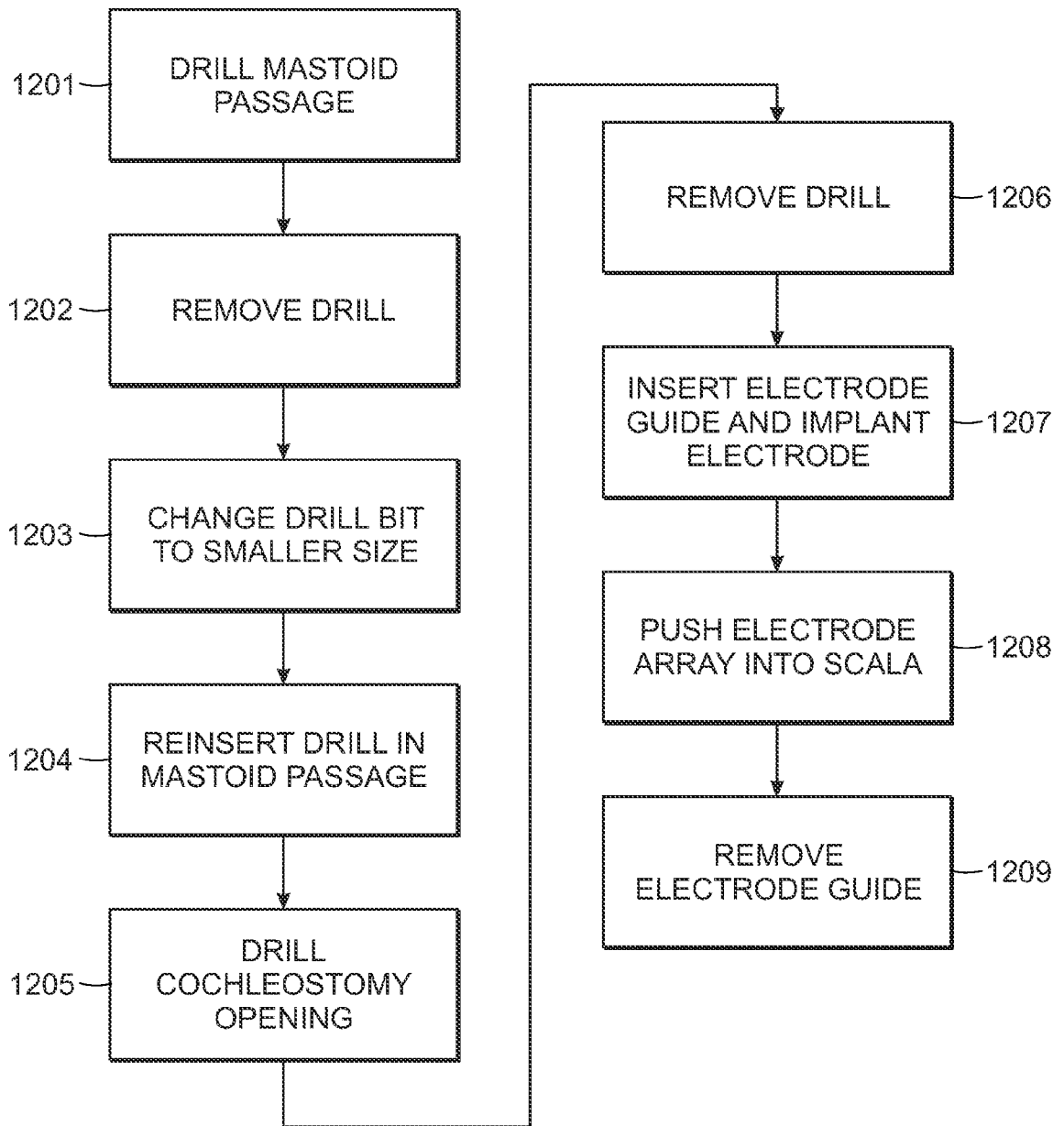

FIG. 12