



US 20100327448A1

(19) **United States**

(12) **Patent Application Publication**
Marcoux

(10) **Pub. No.: US 2010/0327448 A1**

(43) **Pub. Date: Dec. 30, 2010**

(54) **SEMICONDUCTOR WITH BOTTOM-SIDE WRAP-AROUND FLANGE CONTACT**

Publication Classification

(75) Inventor: **Phil P. Marcoux**, Mountain View, CA (US)

(51) **Int. Cl.**
H01L 23/48 (2006.01)
H01L 21/283 (2006.01)

(52) **U.S. Cl. 257/751; 438/612; 438/686; 257/E23.01; 257/E21.159**

Correspondence Address:

The TPL Group
C/O Alliacense Limited LLC
20883 Stevens Creek Boulevard, Suite 100
Cupertino, CA 95014 (US)

(57) **ABSTRACT**

A packaging technique for electronic devices includes wafer fabrication of flexible contacts on the bottom surface of the substrate underneath the active circuit. Inherently reliable contacts suitable for a variety of devices can be formed via a simple fabrication process with good wafer packing density. For one embodiment, a trench is formed from the back of the substrate, exposing an upper conductive layer on the top surface. A standoff is formed on the bottom surface of the substrate. A lower conductive layer is formed that runs from and electrically connects with the exposed portion of the upper conductive layer onto the substrate standoff. The stand-off is removed, releasing the formed conductors, resulting in a flexible contact.

(73) Assignee: **Wafer-Level Packaging Portfolio LLC**, Cupertino, CA (US)

(21) Appl. No.: **12/874,412**

(22) Filed: **Sep. 2, 2010**

Related U.S. Application Data

(62) Division of application No. 12/147,375, filed on Jun. 26, 2008.

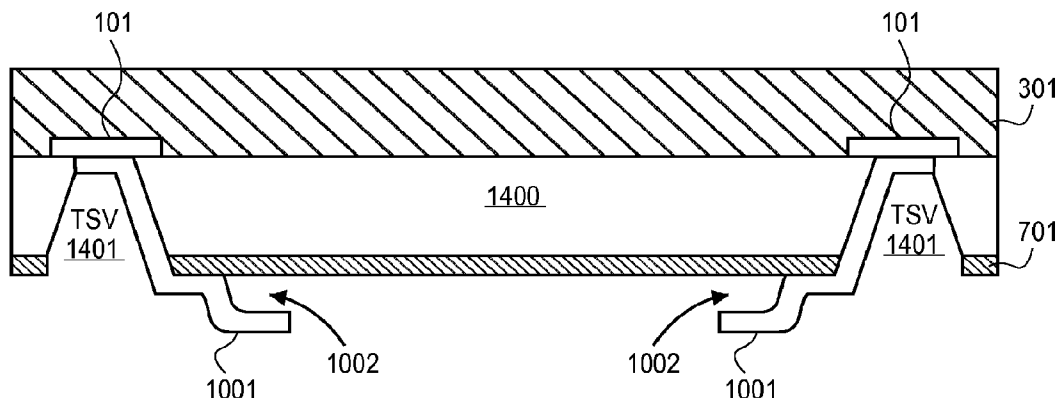

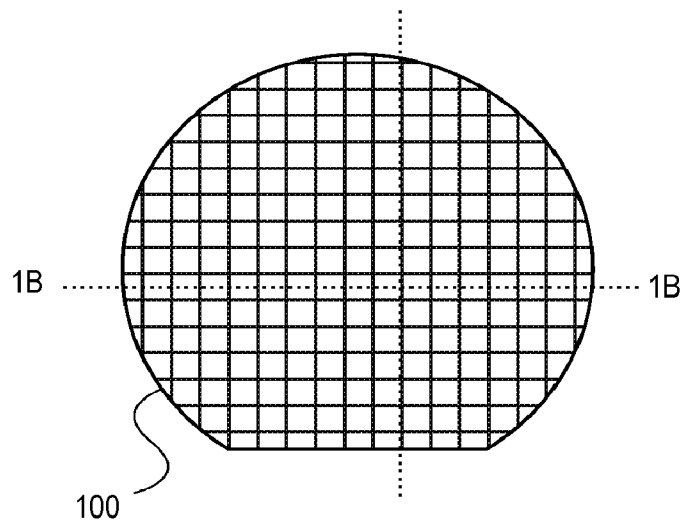

FIG. 1A

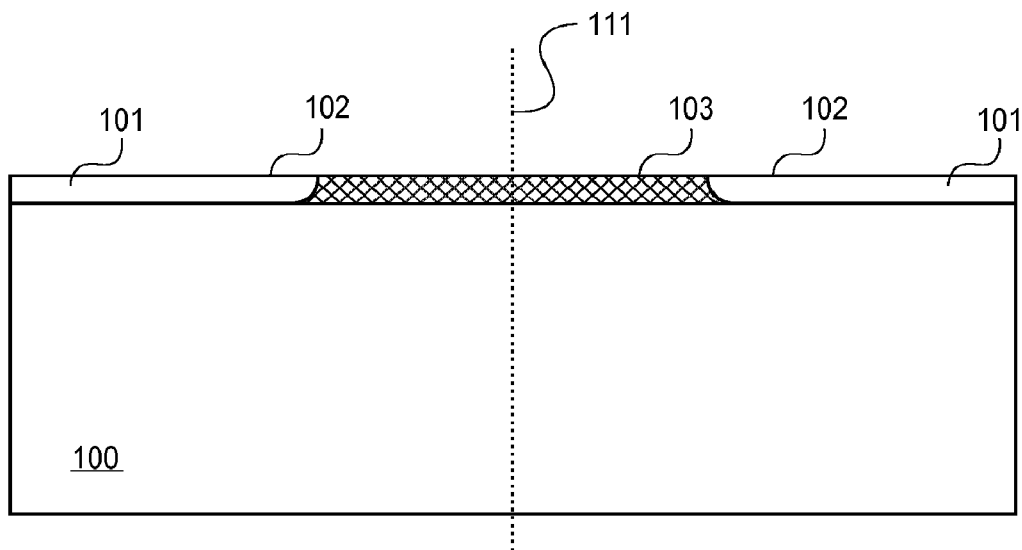

FIG. 1B

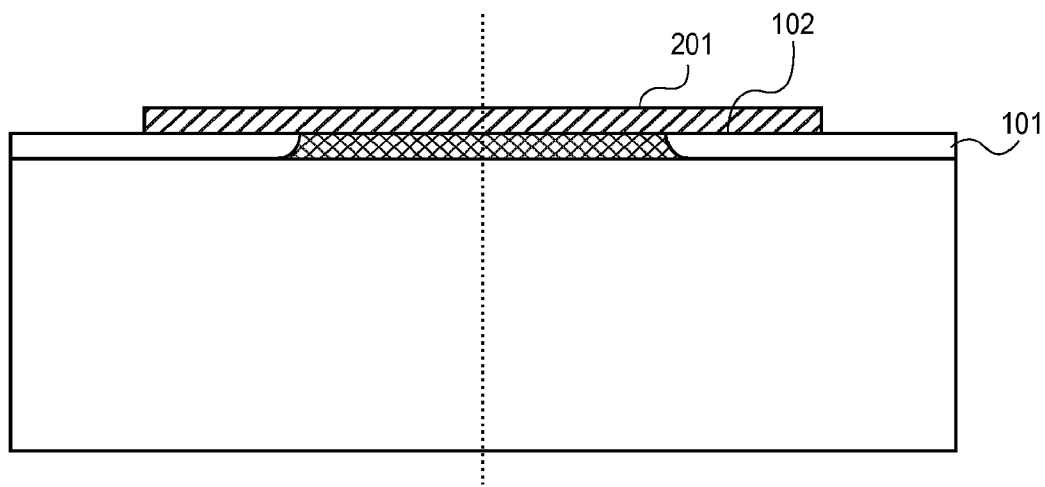

FIG. 2

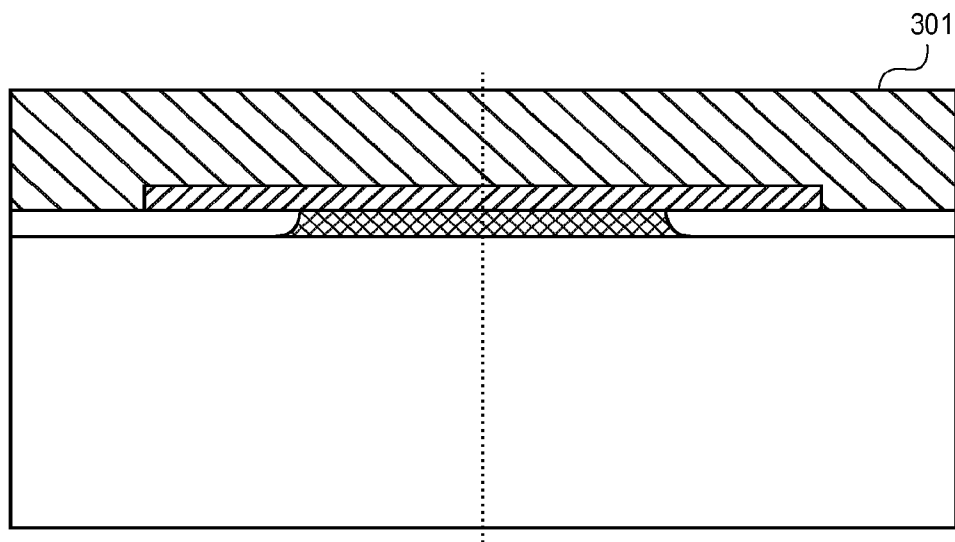

FIG. 3

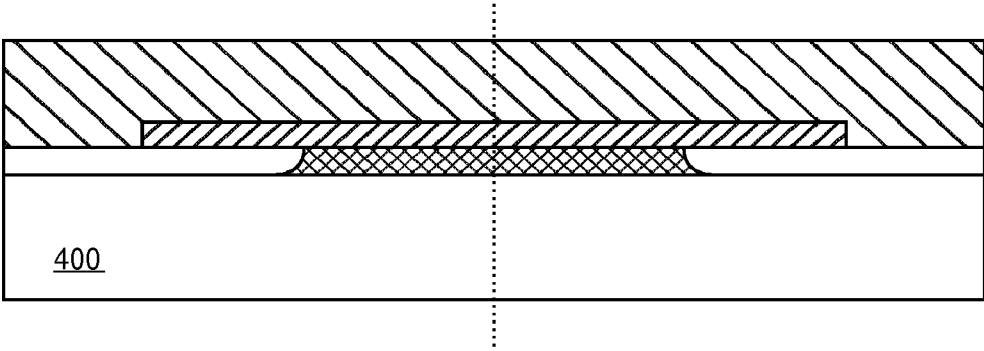

FIG. 4

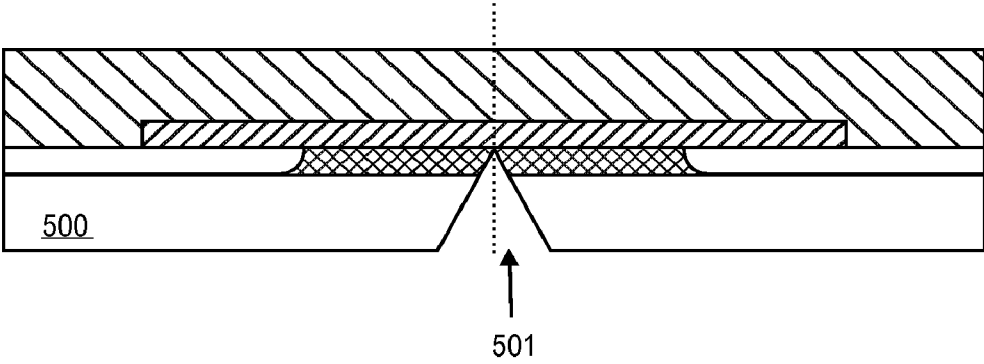

FIG. 5

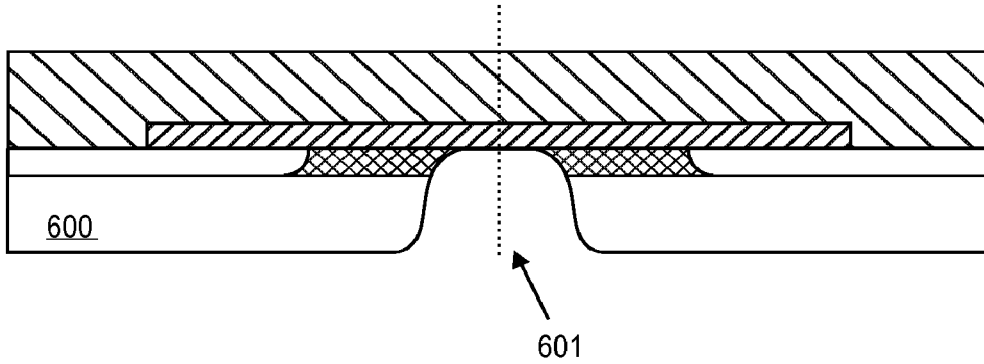

FIG. 6

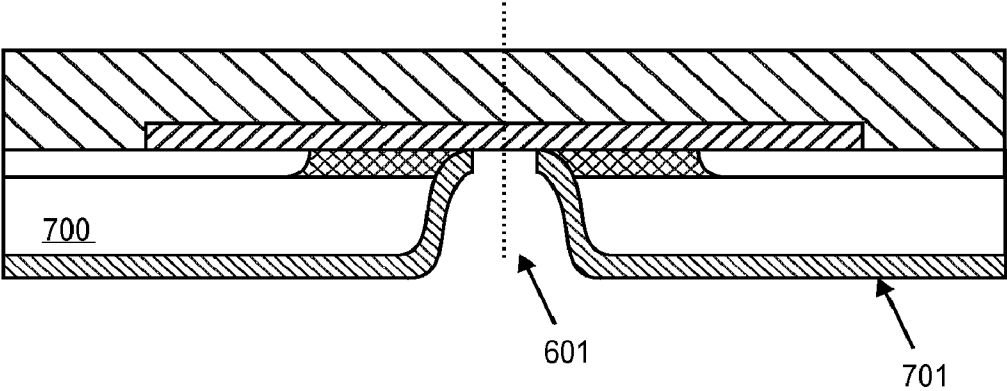

FIG. 7

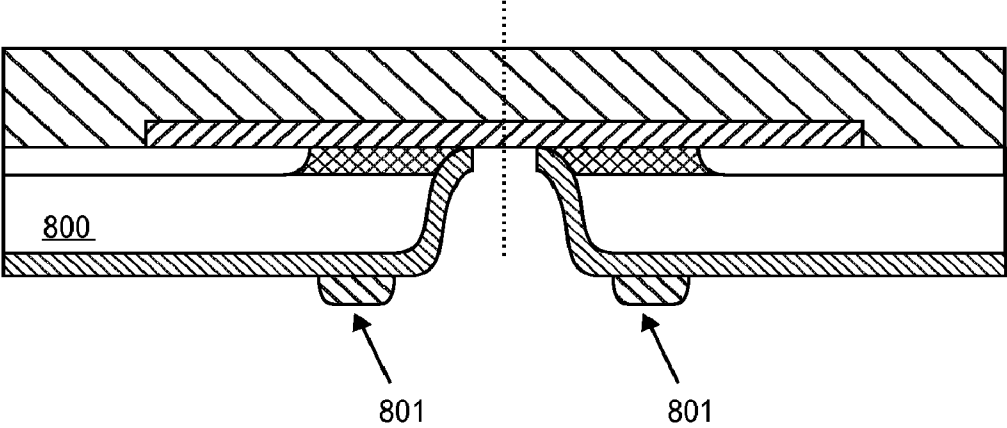

FIG. 8

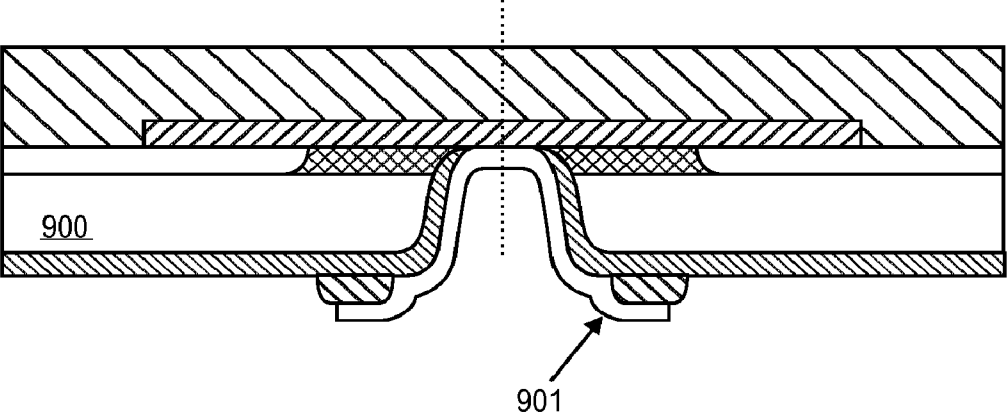

FIG. 9

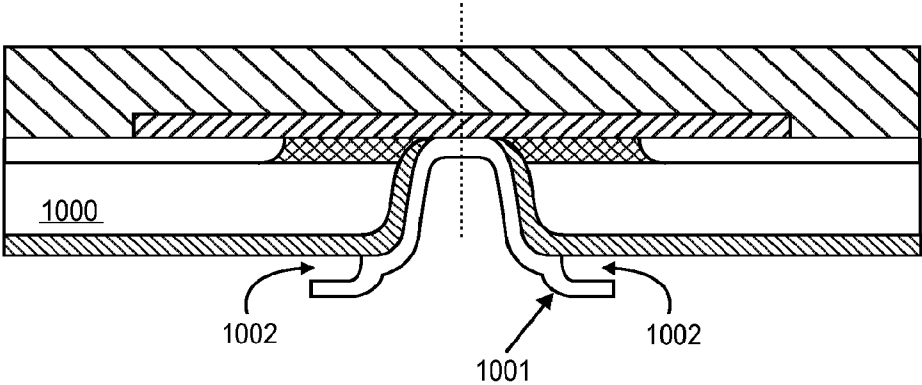

FIG. 10

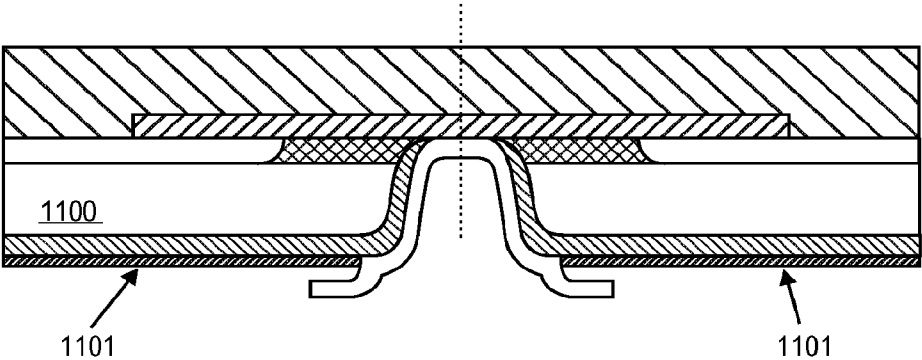

FIG. 11

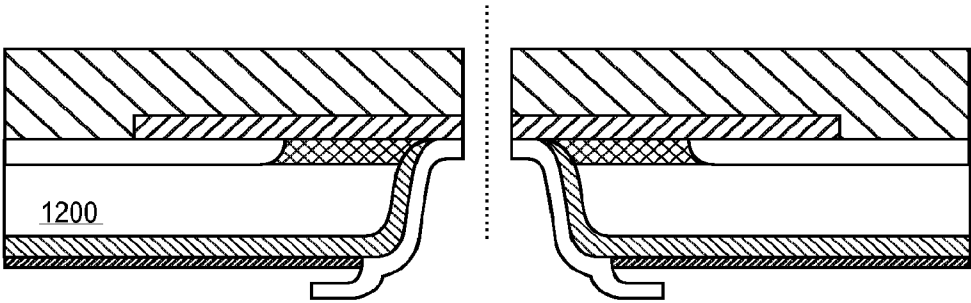

FIG. 12

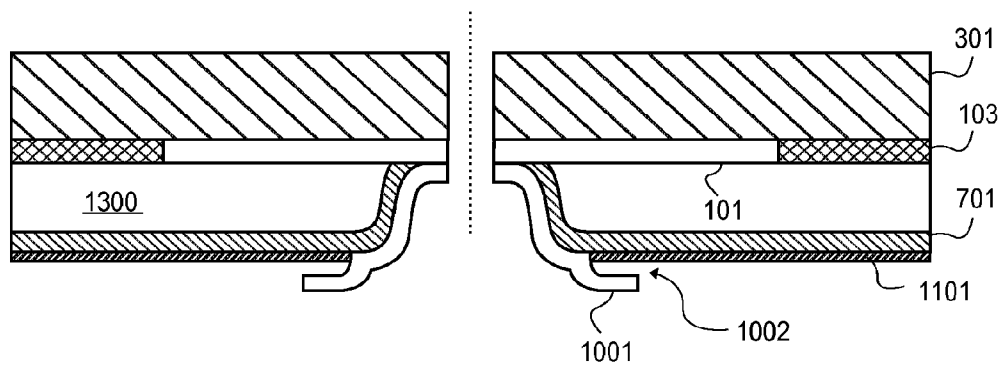

FIG. 13

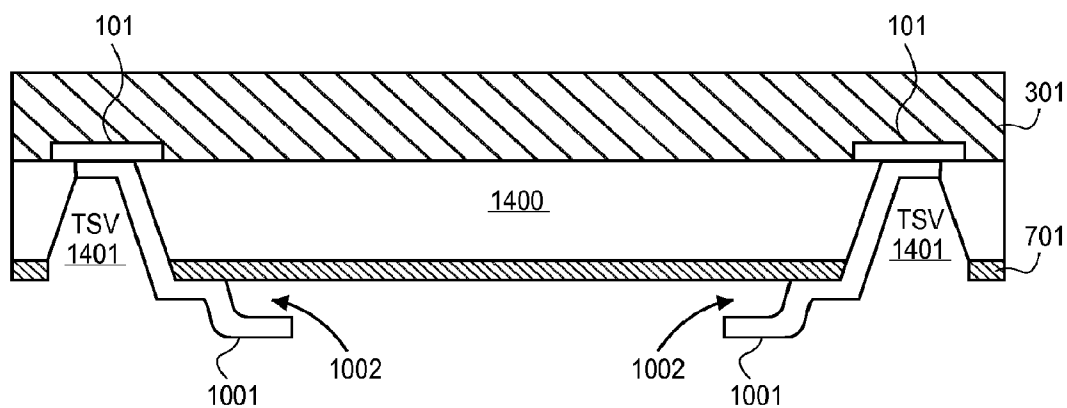

FIG. 14

SEMICONDUCTOR WITH BOTTOM-SIDE WRAP-AROUND FLANGE CONTACT

FIELD

[0001] Embodiments of the present invention relate generally to electronic component packaging. More particularly, these embodiments relate to a wafer level processing for an electronic component packaging having a bottom-side wrap-around flange contact.

BACKGROUND

[0002] Electronic components are packaged in order to interconnect them with other devices. The packaging of the electronic device usually includes contacts for transmitting signals and providing power and ground connections between the internal circuitry of the device and external circuitry. Some examples of prior art contacts include wire bonds protruding from the ends of a discrete diode or resistor, or metal caps located on the ends of a fuse. Sophisticated electronic devices such as microprocessors may require several hundred contacts. Those devices are usually produced in a package having multiple pins for mounting to a printed circuit. The electronic component is typically placed in a package, and each contact area on the electronic component is wire bonded to the corresponding pin on the package. Because each wire bond is individually added to the circuit, large numbers of contacts make wire bonding expensive. Additionally, because of the precision required for wire bonding, wire bonding may result in short circuits and similar problems. Furthermore, wire bonds can degrade chip performance because of the length of the wires.

[0003] One prior art method of solving the problems of wire bonds is the flip chip. Solder balls act as attachment material that allows the flip chip to be attached to a substrate or circuit board. The silicon of the flip chip usually has a different coefficient of thermal expansion (CTE) than that of the substrate or circuit board. The CTE for the flip chip can be as low as 3 parts per million (PPM) while the substrate or circuit board (as well as the solder balls) can be in the range of 18-22 PPM. As a result of the CTE mismatch, the chip and substrate or circuit board expand and contract at different rates due to thermal cycling. A lack of compliance in the contact area can cause failures. Attempts to solve the CTE mismatch have included introducing large volumes of solder. This is contrary, however, to the desires of the market for electronic packaging for smaller, cheaper, and faster components. For example, in U.S. Pat. No. 6,441,487, the inventors specify a minimum sized solder ball that is 229 um (0.009") as a means of improving reliability. The market is seeking the ability to use solder balls smaller than 100 um (0.004").

[0004] U.S. Pat. No. 4,673,967 presented a plastic leaded chip carrier (PLCC) with J-shaped device leads soldered to respective portions of circuit pads on a printed circuit board to minimize space, dissipate heat, and provide some compliancy to a dual in-line package (DIP) for integrated circuits. This PLCC requires a multitude of manufacturing steps, however, such as wire bonding, which includes the complications discussed above, and results in a relatively large package.

[0005] U.S. Pat. No. 6,221,751 presented a circuit package which addressed CTE mismatch by providing lead connections that are not directly on the surface of the die, but instead formed on posts composed of an encapsulant material. This allows for some compliancy and smaller bond pads or junc-

tion areas on the die and thus minimizes the stress on the die surface. Nevertheless, greater flexibility and compliancy is still desired.

SUMMARY

[0006] A method is described for fabricating a contact for an electronic device. The bottom surface of a substrate is thinned. The substrate has an electronic circuit that includes a electrical connection point on the top surface of the substrate. The thinning exposes a portion of the bottom surface of the electrical connection point. A standoff is formed below the bottom surface of the substrate. A lower conductive layer is formed that runs from the standoff and runs to and electrically couples with the exposed portion of the electrical connection point. At least a portion of the standoff is removed to form the flexible conductor.

[0007] An electronic component package is also described that includes a flexible conductor on a bottom side of a substrate. The substrate has an electronic circuit. A gap of air defines the space between a portion of the flexible conductor and a portion of the bottom side of the substrate.

[0008] Other features and advantages of embodiments of the present invention will be apparent from the accompanying drawings and from the detailed description that follows.

BRIEF DESCRIPTION OF THE DRAWINGS

[0009] Embodiments of the present invention are illustrated by way of example and not limitation in the figures of the accompanying drawings, in which like references indicate similar elements, and in which:

[0010] FIG. 1A is a top view of a substrate wafer showing how its top surface is tiled with replications of die, each of which will become an electronic device.

[0011] FIG. 1B is a cross-sectional side view of a portion of the wafer showing the electronic circuit or component areas for two adjacent devices, each having a connection point.

[0012] FIG. 2 is a cross-sectional side view of the wafer portion of FIG. 1B after conductive material has been formed on top of the wafer.

[0013] FIG. 3 is a cross-sectional side view of the wafer portion of FIG. 2 after a relatively thick layer of epoxy has been applied to the top of the wafer and the conductive material, which encapsulates them into a strong and rigid unit.

[0014] FIG. 4 is a cross-sectional side view of the wafer portion of FIG. 3 after the wafer has been thinned from the bottom.

[0015] FIG. 5 is a cross-sectional side view of the wafer portion of FIG. 4 after a notch has been cut into the bottom surface of the wafer between adjacent electronic circuits.

[0016] FIG. 6 is a cross-sectional side view of the wafer portion of FIG. 5 after the wafer has been further thinned selectively from the bottom, which exposes the contacts to the substrate.

[0017] FIG. 7 is a cross-sectional side view of the wafer portion of FIG. 6 after an insulation layer has been applied to the bottom of the wafer and the contacts to the substrate remain exposed.

[0018] FIG. 8 is a cross-sectional side view of the wafer portion of FIG. 7 after a standoff has been formed on the bottom of the wafer according to a pattern to form the post and shape the conductive layer.

[0019] FIG. 9 is a cross-sectional side view of the wafer portion of FIG. 8 after contacts have been formed on the bottom of the wafer according to a pattern.

[0020] FIG. 10 is a cross-sectional side view of the wafer portion of FIG. 9 after the standoff is removed, releasing the formed conductor, resulting in a flexible contact.

[0021] FIG. 11 is a cross-sectional side view of the wafer portion of FIG. 10 after an insulating layer has been deposited on the bottom side of the substrate and a portion of the flexible contact remains exposed.

[0022] FIG. 12 is a cross-sectional side view of the wafer portion of FIG. 11 after the wafer portion has been diced into two electronic devices, each with an attached, flexible contact.

[0023] FIG. 13 is a cross-sectional side view according to an embodiment in which the flexible contacts are coupled directly with the electrical connection points.

[0024] FIG. 14 is a cross-sectional side view according to an alternative embodiment in which the flexible contacts are coupled to the electrical connection points by way of through-silicon vias.

DETAILED DESCRIPTION

[0025] A method and apparatus are described for an electronic component package using wafer level processing and flexible contacts on the bottom side of the substrate under an active or passive circuit. For one embodiment, a trench is formed from the back of the substrate, exposing the contacts on the top surface. A standoff is formed below the bottom surface of the substrate. A lower conductive layer is formed that runs from and electrically connects with the exposed portion of the upper conductive layer onto the substrate standoff. The standoff is removed, releasing the formed conductors, resulting in a flexible contact. Once the floating flexible conductor is formed and the device is soldered to a circuit board, the conductor will flex to absorb the size changes resulting from the mismatch of coefficients of thermal expansion. By forming the contacts on the bottom side of the device, the amount of interference caused by operating at very high frequencies and radiated energy from nearby devices is reduced.

[0026] FIG. 1A illustrates a top view of substrate wafer 100. FIG. 2 shows a corresponding cross section. The top surface of substrate wafer 100 has been used to fabricate a number of integrated circuits each within a rectangular die that is replicated or tiled across the wafer. Cut line or separation plane 111 is one of the planes along which substrate wafer 100 will be separated or diced into individual electronic devices—finished electronic devices, not merely die requiring a subsequent assembly process.

[0027] Any material that is suitable for the fabrication of electronic circuitry and is suitable for shaping via etching, shaving or the like can be used for substrate wafer 100. In some embodiments, substrate wafer 100 is formed of crystalline silicon (Si). Other embodiments use other semiconductors for substrate wafer 100 such as, but not limited to, the following: gallium arsenide (GaAs), silicon germanium (SiGe), silicon carbide (SiC), gallium phosphide (GaP) or the like. For one embodiment, substrate wafer 100 is formed of any III-V semiconductor material. Yet other embodiments use insulative substrates such as, but not limited to, ceramic materials, sapphire, quartz or the like.

[0028] A cross-sectional view of substrate wafer 100 is also shown in FIG. 1B, the cross-section being taken along line

1(b). The top surface of substrate wafer 100 has been used to fabricate an integrated circuit within electronic circuit regions 101. Electronic circuit regions 101 include connection points 102. An electrical signal or power supply voltage must be connected between connection points 102 and circuitry external to the finished electronic device in order for it to operate properly.

[0029] Various techniques for fabricating electronic circuits using substrate wafer 100 are known in the art as well as for attaching fabricated electronic circuits to substrate wafer 100. The description below of the contact fabrication process assumes that the fabrication of the electronic circuit or component or its attachment to substrate wafer 100 has been completed.

[0030] Referring to FIGS. 1A and 1B, electrical connection points 101 suggest an integrated circuit that is fabricated using the top surface of substrate wafer 100. Nevertheless, the techniques and embodiments described throughout this disclosure apply to contacts for any electronic circuit or discrete electronic component that can be fabricated using, or attached to, substrate wafer 100. For example, a passive discrete component, such as, but not limited to, a resistor or capacitor, or an active discrete component such as, but not limited to, a transistor, power transistor, diode, thyristor, field-effect transistor (FET), or the like could include connection points 102 and could have contacts fabricated according to any of the techniques or embodiments disclosed herein. As a further example without limitation, various integrated circuits or other electronic circuits could be attached to substrate wafers 100 could include connection points 102 and could then have contacts fabricated according to any of the techniques or embodiments disclosed herein.

[0031] Generally, an electronic circuit is formed within or attached to square or rectangular shaped electrical connection points 101 that are replicated both horizontally and vertically, covering the top surface of substrate wafer 100. Electrical connection points 101 are gold, silver, nickel, titanium, aluminum, tungsten, copper, platinum, any other conductive material, or combination thereof. Edges of two adjacent electrical connection points 101 are shown in FIG. 1B. Connection points 102 of electrical connection points 101 are typically near those edges, but could be located away from the edge if desired. An insulating layer 103 was deposited and separates electrical connection points 101.

[0032] A potential advantage of the present method of fabricating contacts is higher wafer packing density. That is, the area of substrate wafer 100 that must be dedicated to forming contacts might be reduced over that required. This may allow more replications of electrical connection points 101 to fit on a wafer, thus reducing the manufacturing cost for each device.

[0033] FIGS. 2-12 show the processing of an electronic component. For one embodiment the processing illustrated below occurs at a wafer level prior to the separation of the wafer into individual dies. Wafer level packaging is advantageous because it permits processing to occur simultaneously for multiple dies, and does not require individual handling of the dies. Furthermore, because the dies are prepared in the same process, uniformity of processing is assured. The figures below illustrate a single die. It is understood, however, that the processing is wafer level and occurs with respect to all dies on the wafer substantially simultaneously.

[0034] FIG. 2 illustrates a cross-sectional side view in which the wafer portion of FIGS. 1A and 1B has an upper interconnection conductive layer 201 formed on a region of

substrate wafer **100**. Interconnection conductive layer **201** extends from connection point **102** within electronic circuit region **101** into the portion of wafer surrounding separation plane **111** (for example, 6 to 10 microns thick and 10 microns wide, or a width going up to whatever is appropriate for the current carried). Any technique of forming interconnection conductive layer **201** can be used, such as, but not limited to, pattern plating, sputter deposition of a metal layer within a low-pressure inert gas followed by photo-lithographically selective etching of that layer, or the like.

[0035] Electrical connection points **101** and interconnection conductive layer **201** can be any substance of suitable conductivity—for example, a metal, such as, but not limited to, gold (Au), silver (Ag), copper (Cu), aluminum (Al), nickel (Ni), titanium (Ti), tungsten (W), alloys thereof, or layers thereof. For one embodiment, electrical connection points **101** are aluminum (Al) and interconnection conductive layer **201** is a barrier layer metal composed of layers of titanium (Ti), tungsten (W), nickel (Ni), and gold (Au).

[0036] Interconnection conductive layer **201** as well as the other metal conductive layers, interconnect, or contact layers described herein might be advantageously formed of layers of metals, such as, but not limited to, the following: a thin barrier metal layer (as can allow current to flow between certain metals while avoiding the metals directly touching) or a thin seed metal layer (as can facilitate forming a metal layer by plating), followed by a main layer, followed by a gold flash layer (as can resist corrosion).

[0037] FIG. 3 illustrates a cross-sectional side view of the wafer portion of the FIG. 2 after a relatively thick encapsulation or cover layer **301** (150 microns, for example) of insulation material such as epoxy has been applied to the top of the wafer, which encapsulates substrate wafer **100** and interconnection conductive layer **201** into a strong and rigid unit.

[0038] Encapsulant layer **301** can be formed of epoxy, glass, plastic, polyimide resins, Teflon® silicon oxide (SiO₂), silicon nitride (Si₃N₄), mixtures thereof, layers thereof, or any other material that is non-conducting, relatively rigid and strong, and sufficiently flexible or compliant to allow for thermal expansion both in subsequent wafer processing and in the complete electronic system. Additionally, encapsulant layer holds the wafer flat and rigid when the active substrate is thinned as described herein. For example, Hysol® FP4650 epoxy manufactured by Dexter Electronic Materials, a division of Loctite Corporation, located in City of Industry, Calif., might be suitable for encapsulant layer **301**. As an alternative to being compliant, encapsulant layer **301** can be formed of a material with thermal expansion characteristics similar to those of substrate wafer **100**.

[0039] Encapsulant layer **301** can be applied using a variety of techniques. These techniques may attempt to keep encapsulant layer **301** at a uniform thickness, or to eliminate air bubbles within encapsulant layer **301** or between it and substrate wafer **100** and interconnection conductive layer **201**. For some embodiments, substrate wafer **100** is spun, possibly in a centrifuge, to form encapsulant layer **301**. For alternative embodiments, encapsulant layer **301** comprises a high-temperature insulative epoxy material that is cured in a furnace.

[0040] For some embodiments, encapsulant layer **301** can include a top or cap layer (not shown) containing materials, such as, but not limited to, the following: silicon, polysilicon, amorphous silicon, plastic, glass, epoxy, aluminum, diamond, mixtures thereof, layers thereof, or any other material that is relatively rigid and strong. This cap layer can make the

finished electronic device more mechanically rugged. It can also serve as a thermal conduit to dissipate heat produced by the operating electronic device. This cap layer need not be an insulator.

[0041] FIG. 4 illustrates a cross-sectional side view of the wafer portion of the FIG. 3 after substrate wafer **100** is thinned from its bottom surface resulting in thinner substrate wafer **400**. Any method of removing substrate material from the back of substrate wafer **100** can be used, such as, but not limited to, back planing, back lapping, sandblasting, grinding, wet chemical etching, dry plasma etching, or the like.

[0042] The next step is to selectively remove material from the bottom surface of substrate wafer **400** so as to reduce its substrate thickness along separation plane **111**. Any method of selectively removing substrate material from the back of substrate wafer **400** can be used, such as, but not limited to, the following: diamond saw cutting, photo-lithographically selective wet chemical etching, photo-lithographically selective dry plasma, ion etching, or the like.

[0043] As illustrated in FIG. 5 and FIG. 6, first a diamond-shaped saw cut **501** can be made through the substrate **500** and then selective etching can be used to broaden the cut **601**. For some embodiments, the thinning steps of FIG. 5 and FIG. 6 could be combined into a single step. A sufficient amount of material must be removed that a portion of interconnection conductive layer **201** is exposed on the bottom or the sides of the trench **601**.

[0044] For one embodiment, the interconnection conductive layer **201** is omitted—e.g., when electrical connection points **101** are made of copper (Cu). Without interconnection layer **201**, cuts **501** and **601** remove a sufficient amount of material to expose a portion of the bottom of electrical connection points **101** (not shown). This eliminates the need to open the top of electrical connection points **101** for interconnection layer **201**, which saves a masking step in the application of the first insulating layer **103**. This method also changes the first and final test steps (wafer probe and final test) into one final test point.

[0045] FIG. 7 illustrates a cross-sectional side view of the wafer portion of the FIG. 6 after an insulating layer **701** has been deposited on the bottom and sides of the substrate. Interconnection conductive layer **201** remains exposed as the result of masking or etching or otherwise removing insulating layer **701** from interconnection conductive layer **201**. For one embodiment, this step of depositing insulating layer **701** is omitted—e.g., if the substrate is made of gallium arsenide (GaAs).

[0046] As illustrated in FIG. 8, standoffs **801** are created on the bottom surface of substrate wafer **800** to form posts and shape the conductive layer described below. Standoffs **801** may either be grown, prefabricated and attached, stenciled, or made by other means known in the art. Standoffs **801** are made of polymer plastic, patterned plastic, epoxy, glass, Teflon, silicon dioxide, polysilicon, or any other material which can provide mechanical support for the conductive layer described below. Alternatively, standoffs **801** are made of silicon, gallium arsenide, silicon germanium, silicon carbide, gallium phosphide, ceramic materials, sapphire, quartz, or other substrate materials. For an alternative embodiment (not shown), the standoffs formed will overlap the trench as well as the bottom surface of the substrate wafer **800**. For one embodiment, standoffs **801** are between 25 and 200 microns in height.

[0047] As illustrated in FIG. 9, lower conductive layer or contact layer **901** is formed on the bottom surface of substrate wafer **900** over the insulating layer **701** and over the standoffs **801** according to a pattern. One portion, relative to each finished device, of contact layer **901** connects with the exposed portion of interconnection conductive layer **201**. The other ends of contact layer **901** run onto standoffs **801** thus forming the bottom of each contact being fabricated. Contact layer **901** may end at the inside edge of standoff **801**, or it may fully or only partially cover its bottom surface. The bottom surface dimensions of a contact can vary from contact to contact. It is not necessary for any contact to have the same width or the same length as any other contact. The inter-contact pitch can be variable.

[0048] For some uses of some types of electronic devices, it potentially is a significant advantage to be able to vary the contact's surface area. In the absence of this ability, if the current carrying capacity of a single contact is exceeded, then multiple contacts must be dedicated to carry the same signal or power-supply voltage level. Also, the ability to vary the contact's surface area might help reduce parasitic circuit elements such as resistance and inductance that can be introduced by a contact. Such a reduction could be a significant advantage in some cases, such as for power switching devices.

[0049] Contact layer **901** is formed from a metal or other conductor that facilitates connecting the contacts of the electronic device with the wiring on the surface to which the device is mounted. For embodiments where soldering is used to form connections, contact layer **901** can be made of a conductor such as, but not limited to, the following: nickel (Ni), nichrome-gold, nichrome-nickel, nickel-arsenic-gold, nickel-arsenic, nickel-gold, gold-tin-oxide (ATO), palladium-silicide, titanium (Ti), tungsten (W), titanium-tungsten (Ti—W), indium titanium oxide (ITO), aluminum (Al), copper (Cu), platinum (Pt), alloys thereof or layers thereof. Gold (Au) or silver (Ag) can also be used for contact layer **901**.

[0050] Any method of forming contact layer **901** according to a pattern can be used, including, but not limited to, pattern plating. Pattern plating is not wasteful of materials and can be faster, and result in a higher quality contact layer **901**, than depositing contact layer **901** by evaporation or sputtering.

[0051] Various methods of pattern plating are known and can be used to form contact layer **901**. One such method is as follows. A first layer (0.2 microns thick, for example) of titanium-tungsten (Ti—W) is deposited on the bottom of substrate wafer **900**. A second layer (0.2 microns thick, for example) of gold (Au) is deposited over the first layer. The second layer is then selectively coated by a photo resist layer (6 to 10 microns thick, for example) in the regions where contact layer **901** is not to be formed. Electroplating is then used to form a contact layer **901**, which can actually become thicker than the photoresist layer. The photoresist layer is then stripped off and the first and second layers are etched away where they are not protected by contact layer **901**.

[0052] For one embodiment, prior to depositing the contact layer **901**, a barrier metal such as titanium tungsten (Ti/W) is first sputter deposited over the entire circuit and followed by a plating of nickel (Ni) and a flash of gold (Au). Alternatively, copper (Cu) plating is used. The barrier metal provides a barrier layer between metals and enhances adhesion of the contact layer **901**. For one embodiment, the upper portion of contact layer **901** (closest to the substrate **900** and interconnection conductive layer **201**) and the lower portion of inter-

connection conductive layer **201** consist of the same conductive material. After the deposition of contact layer **901**, the barrier metal layer is etched away from the remaining areas of the electronic component.

[0053] FIG. 10 illustrates the circuit of FIG. 9 with standoffs **801** removed, leaving behind compliant conductive member **1001** and gap **1002**. Standoffs **801** can be removed using photo imaging, chemical etching, plasma etching, or other known techniques. For one embodiment, the removal of standoffs **801** includes removing standoff material in the trench **601** (not shown, as described above) creating a larger gap **1002** that extends into the trench **601**.

[0054] Once the floating flexible conductor **1001** is formed and the device is coupled with a circuit board, the conductor will flex to absorb the size changes, similar to a flange joint, resulting from the mismatch of coefficients of thermal expansion. For one embodiment, the flexible conductor **1001** is patterned to have a suitable surface for coupling with a circuit board via one or more of the following techniques: soldering, ultrasonic bonding, conductive epoxy, or the Occam process. With the Occam process, components are interconnected using copper plating after the components are assembled into their final positions in an encapsulated module. With the Occam process, an assembly containing components is metallized with copper using standard printed circuit build-up processing methods, with circuit patterns created to form the required interconnections between leads of all the components.

[0055] As discussed herein, bottom plating layer of flexible conductor **1001** will accept solder—e.g., gold and nickel, while the top of the flexible conductor **1001** will not—e.g., titanium tungsten. If the top of the flexible conductor **1001** accepted solder, solder would be able to flow or reflow all the way around the flexible conductor **1001** due to gap **1002** when being soldered to a circuit board, causing a loss in compliance.

[0056] FIG. 11 illustrates a cross-sectional side view of the wafer portion of the FIG. 10 with coating layer **1101** deposited on the bottom of the of substrate wafer **1100**. For one embodiment, coating layer **1101** is a polyimide layer, and is deposited by spinning. Alternatively, the coating layer **1101** is another encapsulant or epoxy. For one embodiment, the coating layer **1101** is not deposited on the top of the flexible conductor **1001**. Thus the bottom of flexible conductor **1001** remains electrically conductive. The coating layer **1101** is deposited using a masking process. Alternatively, the coating layer **1101** is deposited uniformly over the entire circuit, and removed from the top of beams **510** using photo imaging techniques. For one embodiment, this step is omitted.

[0057] Coating layer **1101** functions as a solder resist. For one embodiment, coating layer **1101** is approximately 25 um thick while the posts stand off the chip approximately 75 to 100 um. Any of coating layer **1101** that remains on the solder surface of flexible conductor **1001** is so thin that the coating layer is easily penetrated and removed during the reflow solder process joining the package to the circuit board. The bulk of the coating layer **1101**, however, prevents solder from wicking completely over the beam and rendering the beam rigid.

[0058] FIG. 12 illustrates a cross-sectional side view of the wafer portion of FIG. 11 after the wafer portion has been diced into two electronic devices, each with an attached, flexible contact. This separation can be achieved by any method, such as, but not limited to, sawing, etching, or meth-

ods known in the art. The separation formed by sawing or etching forms the outside surface of the electronic device.

[0059] FIG. 13 is a cross-sectional side view according to an alternative embodiment in which the flexible contacts 1001 are coupled to the electrical connection points 101 directly rather than indirectly by means of the interconnection conductive layer 201. The fabrication of the electronic devices is otherwise similar to the description above in reference to FIGS. 3-12.

[0060] For one embodiment, thinning, etching, or cutting 501-601 of the bottom of the device exposes a portion of the bottom surface of one or more electrical connection points 101. An insulating layer 701 is deposited on the bottom and sides of the substrate. Electrical connection points 101 remain exposed as the result of masking or etching or otherwise removing insulating layer 701 from electrical connection points 101. For one embodiment, this step of depositing insulating layer 701 is omitted. Standoffs are created on the bottom surface of the substrate wafer.

[0061] The lower conductive layer or contact layer 1001 is formed on the bottom surface of substrate wafer over the insulating layer 701 and over the standoffs according to a pattern. One portion, relative to each finished device, of contact layer 1001 connects with the exposed portion of electrical connection points 101. The standoffs are then removed, leaving behind compliant conductive member 1001 and gap 1002. For one embodiment, coating layer 1101 is deposited on the bottom of the of substrate wafer.

[0062] FIG. 14 is a cross-sectional side view according to an alternative embodiment in which the flexible conductive contacts 1001 are coupled to the electrical connection points by way of through-silicon vias (TSV) 1401. The fabrication of that embodiment is done in a manner similar to the process described above in reference to FIGS. 3-13. Vias 1401 are formed by etching, for example. Conductive layer 1001 is formed in a manner similar to that of layer 901 of FIG. 9—i.e., layer 1001 can be formed by pattern plating, for example, over a standoff (not shown) that is later removed by photo imaging, chemical etching, plasma etching, or other known techniques.

[0063] In the foregoing specification, the invention has been described with reference to specific exemplary embodiments thereof. It will be evident that various modifications may be made thereto without departing from the broader spirit and scope of the invention. The specification and drawings are, accordingly, to be regarded in an illustrative sense rather than a restrictive sense.

What is claimed is:

1. A method of fabricating a contact for an electronic device, comprising:
 - thinning the bottom surface of a substrate, the substrate having an electronic circuit that includes an electrical connection point on the top surface of the substrate, the thinning to expose a portion of the bottom surface of the electrical connection point;
 - forming a standoff below the bottom surface of the substrate;
 - forming a lower conductive layer that runs from the standoff and runs to and electrically couples with the exposed portion of the electrical connection point; and
 - removing at least a portion of the standoff to create a flexible conductor.

2. The method of claim 1, wherein the electrical connection point comprises one of the following: gold, silver, nickel, titanium, aluminum, tungsten, copper, platinum, or a combination thereof.

3. The method of claim 1, wherein the standoff is between 25 and 200 microns in height.

4. The method of claim 1, further comprising: depositing an insulating layer on the bottom surface of the substrate prior to forming the standoff, wherein the electrical connection point remains exposed.

5. The method of claim 4, further comprising: removing a portion of the insulating layer between the substrate and the conductive layer to create the flexible conductor.

6. The method of claim 1, further comprising: forming an encapsulant layer above the top surface of the substrate.

7. The method of claim 1, wherein the lower conductive layer comprises one of the following: gold, silver, nickel, titanium, aluminum, tungsten, copper, platinum, or a combination thereof.

8. The method of claim 1, further comprising: depositing a second insulating layer on the bottom surface of the substrate after removing at least a portion of the standoff, wherein a lower portion of the flexible conductor remains exposed.

9. The method of claim 1, wherein the lower conductive layer comprises a bottom layer to accept solder and a top layer to reject solder.

10. The method of claim 1, wherein a barrier metal layer is deposited, prior to the conductive layer, on at least a portion of the area to be covered by the conductive layer.

11. The method of claim 1, further comprising: coupling the flexible conductor with a printed circuit board using one or more of the following: solder, ultrasonic bonding, conductive epoxy, or plated conductors.

12. A method of fabricating a contact for an electronic device, comprising:

- forming an upper conductive layer above the top surface of a substrate, the substrate having an electronic circuit that includes an electrical connection point, the upper conductive layer having an inner portion connected to the electrical connection point and an outer portion extending beyond the edge of the electronic circuit;

- thinning the bottom surface of a substrate to expose a portion of the bottom surface of the upper conductive layer;

- forming a standoff below the bottom surface of the substrate;

- forming a lower conductive layer that runs from the standoff and runs to and electrically couples with the exposed portion of the upper conductive layer; and

- removing at least a portion of the standoff to create a flexible conductor.

13. The method of claim 12, wherein the electrical connection point comprises one of the following: gold, silver, nickel, titanium, aluminum, tungsten, copper, platinum, or a combination thereof.

14. The method of claim 12, wherein the upper conductive layer comprises one of the following: gold, silver, nickel, titanium, aluminum, tungsten, copper, platinum, or a combination thereof.

15. The method of claim 12, wherein the standoff is between 25 and 200 microns in height.

- 16.** The method of claim **12**, further comprising:
depositing an insulating layer on the bottom surface of the substrate prior to forming the standoff, wherein the upper conductive layer remains exposed.
- 17.** The method of claim **16**, further comprising:
removing a portion of the insulating layer between the substrate and the conductive layer to create the flexible conductor.
- 18.** The method of claim **12**, further comprising:
forming an encapsulant layer above the top surface of the substrate.
- 19.** The method of claim **12**, wherein the lower conductive layer comprises one of the following: gold, silver, nickel, titanium, aluminum, tungsten, copper, platinum, or a combination thereof.
- 20.** The method of claim **12**, further comprising:
depositing a second insulating layer on the bottom surface of the substrate after removing at least a portion of the standoff, wherein a lower portion of the flexible conductor remains exposed.
- 21.** The method of claim **12**, wherein the lower conductive layer comprises a bottom layer to accept solder and a top layer to reject solder.
- 22.** The method of claim **12**, wherein a barrier metal layer is deposited, prior to the lower conductive layer, on at least a portion of the area to be covered by the conductive layer.
- 23.** The method of claim **12**, further comprising:
coupling the flexible conductor with a printed circuit board using one or more of the following: solder, ultrasonic bonding, conductive epoxy, or plated conductors.
- 24.** An electronic component package comprising:
a flexible conductor on a bottom side of a substrate, the substrate having an electronic circuit, wherein a gap of air defines the space between a portion of the flexible conductor and a portion of the bottom side of the substrate.
- 25.** The electronic component package of claim **24**, wherein the flexible conductor is electronically coupled with an electrical connection point on the top side of the substrate through a trench formed in the bottom side of the substrate.
- 26.** The electronic component package of claim **25**, wherein the electrical connection point comprises one of the following: gold, silver, nickel, titanium, aluminum, tungsten, copper, platinum, or a combination thereof.
- 27.** The electronic component package of claim **24**, further comprising:
an insulating layer between a portion of the bottom surface of the substrate and the flexible conductor.
- 28.** The electronic component package of claim **24**, further comprising:
an encapsulant layer above the top surface of the substrate.
- 29.** The electronic component package of claim **24**, wherein the flexible conductor comprises one of the following: gold, silver, nickel, titanium, aluminum, tungsten, copper, platinum, or a combination thereof.
- 30.** The electronic component package of claim **24**, wherein the flexible conductor comprises a bottom layer to accept solder and a top layer to reject solder.
- 31.** The electronic component package of claim **24**, further comprising:
a barrier metal layer on the top side of the flexible conductor, the top side of the flexible conductor being the side closest to the substrate.
- 32.** The electronic component package of claim **25**, wherein the flexible conductor is directly coupled to the electrical connection point on the top side of the substrate.
- 33.** The electronic component package of claim **24**, wherein the flexible conductor is electronically coupled with an electrical connection point on the top side of the substrate by means of a through-silicon via formed in the bottom side of the substrate and the flexible conductor partially resides within the through-silicon via.

* * * * *