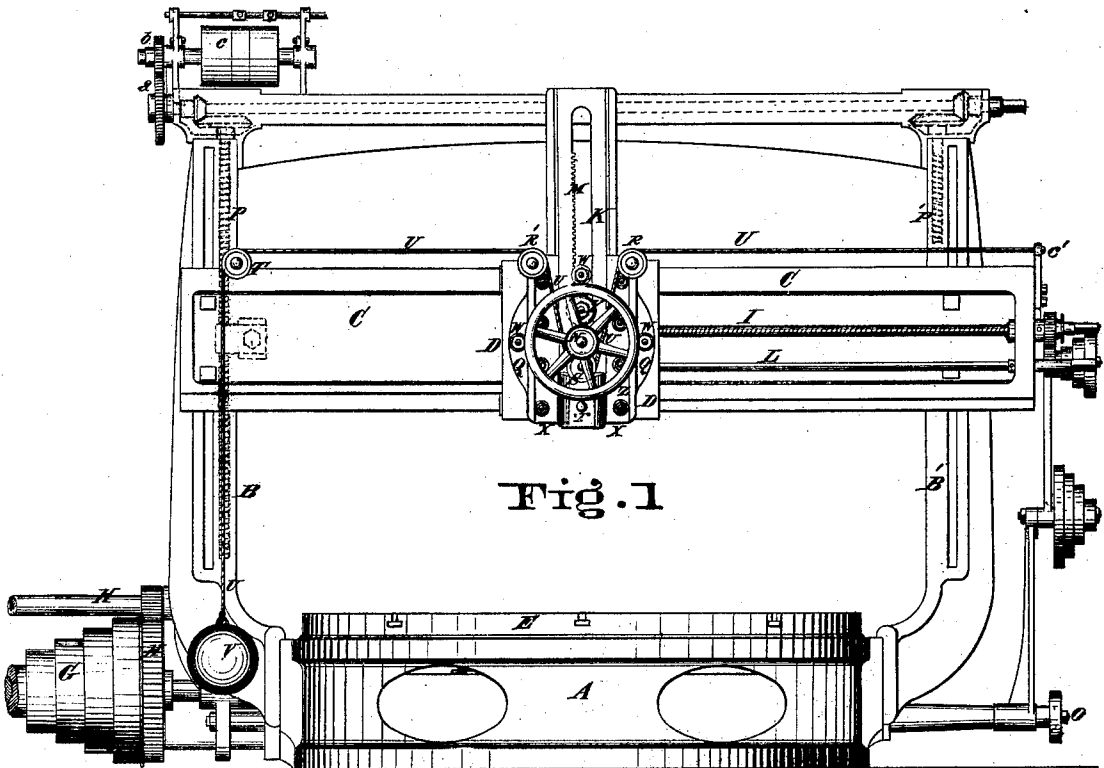


*G. A. Gray, Jr.,*

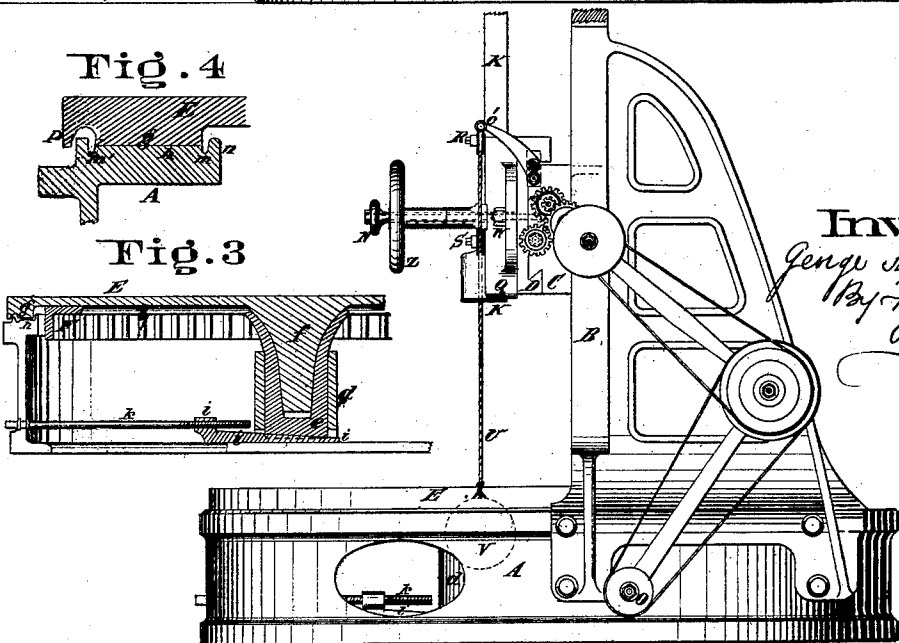
*Boring Mill.*

*No. 113,651.*

*Patented Apr. 11, 1871.*

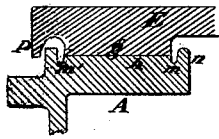


**Fig. 1**

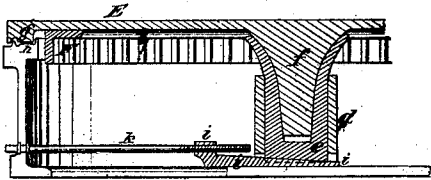


**Fig. 2**

**Fig. 4**



**Fig. 3**



**Inventor**  
*Geno A. Gray, Jr.*  
*By H. Millward*  
*Attorney*

**Attest**

*Henry Millward*  
*Eliza H. Layman*

# United States Patent Office.

GEORGE A. GRAY, JR., OF CINCINNATI, OHIO.

Letters Patent No. 113,651, dated April 11, 1871.

## IMPROVEMENT IN TURNING AND BORING-MILLS.

The Schedule referred to in these Letters Patent and making part of the same.

To all whom it may concern:

Be it known that I, GEORGE A. GRAY, JR., of Cincinnati, Hamilton county, State of Ohio, have invented certain new and useful "Improvements in Turning and Boring-Mills;" and I do hereby declare the following to be a sufficiently full, clear, and exact description thereof to enable one skilled in the art to which my invention appertains to make and use it, reference being had to the accompanying drawing making part of this specification.

### Nature and Objects of Invention.

My invention consists—

First, in a peculiar device for balancing the tool-bar in any position within its range in such a way as to keep the weight up against the feed, and thus prevent the bar being forced up by the work when any slack exists in the feed, and permit of the bar being elevated and depressed freely by hand; this balancing device differing from all others for the same purpose in this, that the bar can be moved to any degree of angularity from an upright or other position, and moved with its saddle along the rail horizontally, without changing the location of the weight which balances the bar.

Second, in a peculiar construction of the outer bearing, by which the oil is collected and prevented from escaping, and also protected from dirt or turning chips.

### Description of the Accompanying Drawing.

Figure 1 is a front elevation of a boring and turning-mill embodying my invention.

Figure 2 is a side elevation of the same.

Figure 3 is a vertical section of a part of the table and the devices for supporting and operating it.

Figure 4 is a section exhibiting the peculiar construction of the outer bearing of the table.

### General Description.

A is the bed-plate of the mill;

B B', the housings;

C, the rail; and

D, the horizontally sliding saddle, which is snugly fitted to and slides upon the rail.

E is the revolving table, operated in the usual way by the large gear-wheel F, driven (through suitable connections) by the cone-pulley G and "back-gear" H.

The feeding mechanism for giving a horizontal movement to the saddle and a vertical or inclined movement to the tool-bar does not differ materially from others for the same purpose, the saddle being moved by the screw I, and the tool-bar K by the rod L, the connection to the bar K being made by a worm, friction-clutch, worm-wheel, and pinion gearing into the rack M on the bar.

The down-feed can be stopped by the slackening of the wheel N, which governs the friction-clutch.

Both the cross and down-feed are driven by the expansible gearing shown operated by the shaft O.

The rail C is designed to be raised and lowered by power, the side screws P P' and connecting driving-shaft on the top rail being provided for this purpose.

The swing Q, in which the bar K slides, is constructed as usual in such a way that the bar can be swiveled to any desired angle to enable the machine to bore and turn tapering, &c.

In order to balance the weight of the tool-bar in any position, whether inclined or vertical, in a way that will possess none of the faults attributable to devices heretofore existing for this purpose, I have provided the following device:

Pulleys R R' are journaled upon the swing Q, pulley S upon the tool-bar, and pulley T upon the end of the rail.

A rope, chain, or wire cord, U, fastened at one end upon the rail, at c', is then passed over the pulley R under the pulley S, over the pulley R', and over the pulley T, where it supports a weight, V, which must be slightly heavier than half the weight of the bar K only. This device suffices to keep the bar up snugly against the force that feeds it down, so that the tool can never drop when "slack exists in the feed." It also enables the swing Q to be moved to a very extreme angle without deranging any of the parts or materially changing the effect of the weight V upon the bar, or even disturbing the weight itself.

The bolts W serve to secure the swing in any position to which it may be adjusted, they being fitted to a circular "T-headed" groove in the saddle D.

The tool-bar slides between the gibs X on the swing, carrying, of course, the pulley S with it. If it is necessary to secure the bar firmly in any given position the bolt Y is designed to accomplish it.

The bar K can be elevated and depressed by hand easily (being balanced) by means of the hand-wheel Z, which has a pinion upon its stem gearing into the rack M. When the bar K is lowered the weight V is elevated, and when the bar K is raised the weight V descends, the weight always moving at twice the velocity of the bar. The rope or chain U is made sufficiently long to permit of the weight being unhooked from it and reattached lower down when the rail C is elevated; or the chain may pass through the floor into a cellar, having sufficient vertical height for the entire range of the weight.

The apparatus a b c, when connected to the line of driving shafting by belts, is used through suitable vertical side screws to raise and lower the rail C. This

device, however, is old and well known, and forms no part of my invention.

The revolving table E I have constructed in such a way that at the will of the operator it may be made to revolve on a central shaft or journal only for fast speed and small work; or to revolve upon an annular horizontal bearing of large diameter in connection with the central journal for large, heavy work.

The construction I have devised to accomplish this is as follows:

A cylindrical socket, *d*, is formed in the frame A of the machine. This socket is fitted with a sleeve, *e*, constructed to slide vertically and snugly in the socket. A bearing is formed in this sleeve *e* for the central journal *f* of the table E. The journal *f* may have the "shiel curve" configuration, as shown, or may be either conical or cylindrical.

The outer rim *g* of the table is "faced off" on the under side for a bearing surface, and made to rest, when adjusted for large work, upon the annular horizontal bearing *h* of the frame A.

A wedge, *i*, is fitted into the socket *d* in such a way that it rests upon the foundation-plate of the frame A, and supports the sliding sleeve *e* and sometimes the table E.

The wedge *i* is operated by a screw, *k*, and, being fitted into a recess cut tapering across the bottom of the sleeve, prevents the latter turning in its socket.

By the simple adjustment of the screw *k* and wedge *i* the table E can be elevated so as to be entirely relieved from the bearing *h*. In this condition the table is supported by the wedge, and can be revolved at a high speed for light small work or polishing.

When the wedge is drawn back so that the table falls to a support upon the bearing *h* the machine is adapted for heavy work, the outer bearing preventing

the tremor incident to boring-mills having only a central bearing when under a "heavy cut."

The outer bearing *h* is provided, on its inner and outer edges, with circular grooves *m m'*, and elevated circular lips *n n'*. The grooves form circular pockets for collecting sediment from the oil, and the lips serve to form a chamber or chambers for the accumulation of oil, and enable the bearing *g h* to be buried in oil. The oil is fed or supplied through suitable apertures drilled through the table into the face of the bearing *g*. The central bearing *e* is supplied with oil through a hole drilled in the journal *f*.

The outer edge of the table E is provided with a pendent circular lip, *p*, which projects over the outer lip *n'*, and serves to prevent dirt, dust, or turning chips from getting into the bearing *g h*.

The lower end of the tool-bar K is bored with a tapering hole or socket for the reception of the ordinary tool-holder, which is secured in the socket of the bar K by means of tapering pin *r*.

*Claim.*

1. The tool-bar balancing device herein described, consisting of rope or chain U, weight V, and pulleys R R' S T, connected and operating substantially as and for the purpose specified.

2. In connection with the outer bearing *g h*, the grooves *m m'*, and lips *n n' p'*, as described, and for the purpose specified.

In testimony of which invention I hereunto set my hand.

G. A. GRAY, JR.

Witnesses:

J. L. WARFMANN,  
ELITHA F. LAYMAN.