

(No Model.)

2 Sheets—Sheet 1.

F. G. HOOPES.
BARREL MACHINE.

No. 524,550.

Patented Aug. 14, 1894.

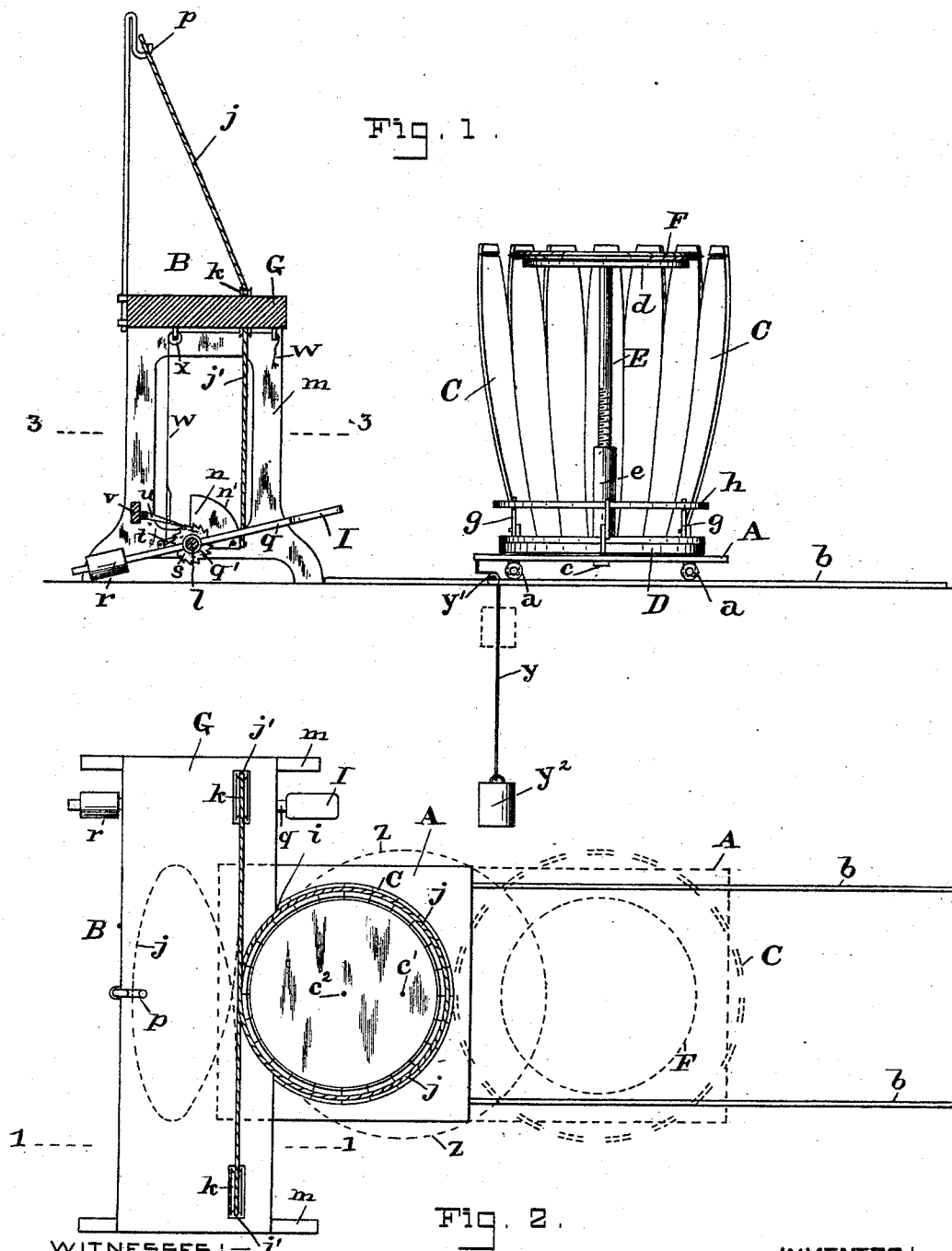

WITNESSES:—
L. I. Van Horn,
Charles B. Mann Jr.

INVENTOR:—
Frank G. Hoopes
 By *Chas B. Mann*
 ATTORNEY.

(No Model.)

2 Sheets—Sheet 2.

F. G. HOOPES.
BARREL MACHINE.

No. 524,550.

Patented Aug. 14, 1894.

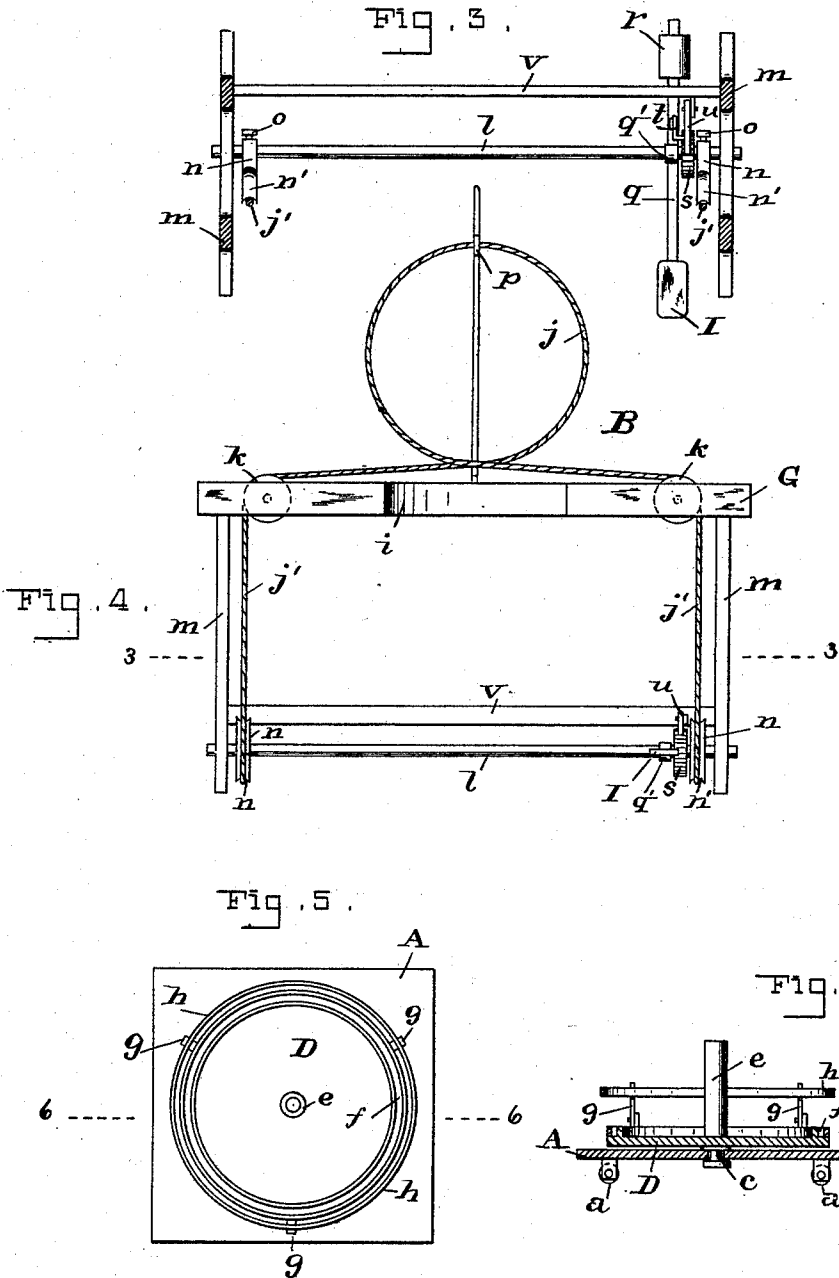

WITNESSES:—
L. L. Van Horn.
Charles B. Mann Jr.

INVENTOR:—
Frank G. Hoopes
 By *Chas B. Mann*
 ATTORNEY.

UNITED STATES PATENT OFFICE.

FRANK G. HOOPES, OF BALTIMORE, MARYLAND.

BARREL-MACHINE.

SPECIFICATION forming part of Letters Patent No. 524,550, dated August 14, 1894.

Application filed February 3, 1894. Serial No. 498,953. (No model.)

To all whom it may concern:

Be it known that I, FRANK G. HOOPES, a citizen of the United States, residing at Baltimore, in the State of Maryland, have invented certain new and useful Improvements in Barrel-Machines, of which the following is a specification.

This invention relates to a barrel-making machine, and has for its object to provide mechanical devices for facilitating the operations of setting up the staves to form the barrel, and placing in one head. By means of the improved mechanism which my invention provides, the operations named involve less manual labor than formerly, thus enabling one workman to accomplish more in a given time, and consequently reducing the cost of manufacturing barrels.

The invention is illustrated in the accompanying drawings, in which—

Figure 1 shows a side elevation of the improved form for setting up the staves, and a vertical cross-section of the windlass for tightening or closing the flared ends of the staves. Fig. 2 is a plan view of the same parts, and shows by broken lines the lateral movement of the setting-up form, whereby when the staves are set up the form and staves are moved toward the windlass. Fig. 3 is a horizontal section of the improved windlass on the line 3—3. Fig. 4 is a front elevation of the improved windlass. Fig. 5 is a top or plan view of the setting-up form. Fig. 6 is a vertical section of the same.

It is contemplated here that barrels made by this improved machinery shall have the staves crozed and chamfered previous to being set up.

The setting-up form rests on a base, A, which is mounted so as to slide or be movable laterally toward and away from the windlass, B; in the present instance this movement is effected by means of rollers, *a*, placed under the base, and free to travel on a suitable track, *b*. Of course this lateral movement of the "setting-up form" may be effected by any other means.

The staves, C, are set up with their lower ends seated in the setting-up form, and their other ends open or flaring.

The disk, D, is centrally pivoted at, *c*, upon the laterally-movable base, A, and may be turned on its pivot. This pivot allows the setting-up form, and the barrel-staves that are supported in it, to be turned or revolved, and thereby the operator can have full access to all parts without himself walking around the form. A standard, E, rises from the disk and has at its top-end a seat, *d*, whereon the head, F, of a barrel may be supported, as shown in Fig. 1. As the sole function or use of this standard is to support the barrel-head, F, in proper position to be received into the croze of the open or flared ends of the staves, it is immaterial how it is constructed. To enable it to support a barrel-head either at a higher or lower position, I make it in the form of a telescopic screw, as shown; one part of the standard, E, is thus screw-threaded and enters another part, *e*, which is socketed to receive it.

The disk, D, has a circular channel, *f*, to receive the ends of the staves, and studs, *g*, to support a hoop, *h*. The staves are set up in this form in the usual manner, and all the staves at one end are held tightly together as usual while the upper ends are open and flaring. The setting-up form, with the staves and one head in the position shown in Fig. 1, is then by means of my improvement moved laterally toward the windlass to have the flared ends of the staves contracted and closed about the head, F.

The windlass has a top-bar, G, provided with the usual concave, *i*, against which the side of the barrel comes when the setting-up form is moved laterally toward it. The rope which forms the loop, *j*, to encircle the barrel and thereby contract or draw together the flared ends of the staves, is arranged to have both ends drawn at the same time. When the rope loop is not in use it is supported above the bar, G, by a hook, *p*, in the usual manner, see Figs. 1 and 4. The top bar carries two rollers, *k*, over which pass the two ends, *j'*, of the rope after they come from the loop; a rock-shaft, *l*, is mounted in the frame, *m*, of the windlass and carries two sectors, *n*, each of which is made fast to the shaft by a set-screw, *o*; the curved face or end of the

sector has a groove, n' , and one rope-end is attached to one sector (see Figs. 1 and 4) and the other rope-end to the other sector. The arrangement is such that the rope-loop, j , is largest when the two sectors are turned with the point of attachment of the rope-ends at the upmost position, and said rope-loop is smallest when the two sectors have been turned downward so as to draw down the rope ends over the grooved faces, n' .

The rock-shaft is operated by a treadle, I, and a suitable clutch device. In the present instance the treadle bar, q , has an eye, q' , which is loose on the rock-shaft, l , and at its rear end the bar carries a weight, r ; thus when the foot is removed from the depressed treadle the weight, r , at the opposite end will tilt the treadle up in position to be again depressed. A ratchet-wheel, s , is keyed fast on the rock-shaft alongside of the treadle bar, and a pawl, t , is pivoted upon and is carried by the treadle bar so as to engage said ratchet wheel when the treadle is depressed, and by pushing said wheel cause the rock-shaft to turn, but to disengage from and slip back over the teeth, of the wheel, s , when the weight, r , on the bar tilts the treadle up. Another pawl, u , is pivoted to a cross-bar, v , and this also engages the ratchet-wheel, s , and serves to hold it whenever the push pawl, t , has turned it. It will be seen that a depression of the treadle, I, will, through the action of the push pawl, t , rock-shaft and sectors, n , draw on both ends, j' , of the rope at the same time and thus reduce the size of the loop, and when the loop is around the flared ends of the barrel staves the said flared ends will be contracted or drawn together, and permit a hoop to be placed around them. After a truss hoop has been placed on, it is necessary to disengage both pawls, t , u , from the ratchet-wheel, s , in order to release the rope-loop and turn it up and support it on the hook, p . To thus disengage the pawls any suitable means may be employed; in the present instance a cord, w , passes over rollers, x , and then downward and a bifurcated or double end attaches to the two pawls; by drawing on the upper end of the cord both pawls will be disengaged.

The base, A, and setting-up form carried by the base are kept normally in a position removed away from the windlass, by means of a cord, y , attached to the base, passed over a pulley, y' , and a weight, y'' , attached to the cord beyond the pulley. This weight device will keep the "setting-up form" in the proper position away from the windlass during the time the staves are being set-up, and will allow the setting-up form to be moved laterally toward the windlass when the flared ends of the staves are to be contracted, and then the weight and cord will operate to move it back again.

The operation is as follows: When the staves have been set up, the "form," with the staves in position, is to be moved laterally by

sliding the base, A, toward the windlass until the flared staves come in contact with the top-bar, G, as indicated by the large broken-line circle, z , in Fig. 2; the rope-loop, J, is then placed around the flared staves having a circumference indicated by the circles, z . The lateral or sliding movement is effected without disturbing the level of the barrel staves, and, of course, the croze of the staves will certainly engage the head, F. The co-action of the laterally-movable "setting-up form" with the rope-loop and windlass will now be seen in the fact that as the rope-loop gradually closes or contracts the flared ends of the staves by the action of the treadle the circle or circumference of said flared ends is gradually reduced in size, and as this reduction proceeds the "setting-up form" continues to gradually and automatically move laterally toward the windlass; this co-acting automatic movement is indicated in Fig. 2 by the small dots, c' , c'' . The dot, c' , represents the position of the center or pivot of the large circle, z (which is the circle described by the flared ends of the staves) at the moment the rope-loop is placed around the staves; while the dot, c'' , represents the position of the center or pivot of the circle which the barrel-head, F, describes at the moment the said staves are tight about the barrel-head; the distance between these two dots represents the extent of the lateral movement of the setting-up form. When the flared ends of the staves have been brought together a hoop is placed around them and will hold them and the head, F, in position after the rope-loop has been removed. The barrel may now be lifted from the setting-up form, and then the hoops applied, and the barrel finished by any approved method of machinery.

By the method here described a barrel can be "fired" after the staves have been drawn together in barrel form, and also it is possible to truss a barrel when deemed necessary.

Having thus described my invention, what I claim as new, and desire to secure by Letters Patent, is—

1. In a barrel-making machine, the combination of a base; a setting-up form; a pivot centrally connecting the base and setting-up form, so that the latter may be turned or revolved; a top-bar provided with a side concave; and means to slide or move the said base and setting-up form laterally toward said top-bar.

2. In a barrel-making machine, the combination of a laterally-movable base; a setting-up form to receive the lower ends of the barrel-staves; a bar provided with a slide concave; a barrel-head support which rises from the setting-up form; and a windlass having a rope-loop to automatically move the said base and setting-up form laterally toward the concave bar as the rope-loop gradually closes or contracts the flared ends of the staves.

3. In a barrel-making machine, the combina-

tion of a laterally-movable base; a setting-up
form to receive the lower ends of the barrel-
staves; a windlass frame having at opposite
ends a roller, *k*; a rock-shaft mounted in the
5 frame and carrying two sectors, *n*; a rope-
loop each end of which passes over one of the
said rollers and is attached to one of the sec-
tors; a treadle; and means operated by the
treadle to turn the rock-shaft and thereby

draw on both ends of the rope-loop at the 10
same time.

In testimony whereof I affix my signature in
the presence of two witnesses.

FRANK G. HOOPES.

Witnesses:

CHARLES B. ADAMS, Jr.,
C. CALVERT HINES.