



(12) **DEMANDE DE BREVET CANADIEN
CANADIAN PATENT APPLICATION**

(13) **A1**

(86) Date de dépôt PCT/PCT Filing Date: 2020/09/24
(87) Date publication PCT/PCT Publication Date: 2021/04/01
(85) Entrée phase nationale/National Entry: 2022/03/07
(86) N° demande PCT/PCT Application No.: IB 2020/058925
(87) N° publication PCT/PCT Publication No.: 2021/059179
(30) Priorité/Priority: 2019/09/25 (SE1951085-8)

(51) Cl.Int./Int.Cl. *E04F 15/02* (2006.01)
(71) Demandeur/Applicant:
VALINGE INNOVATION AB, SE
(72) Inventeur/Inventor:
BOO, CHRISTIAN, SE
(74) Agent: SMART & BIGGAR IP AGENCY CO.

(54) Titre : PANNEAU DOTE D'UN DISPOSITIF DE VERROUILLAGE
(54) Title: PANEL WITH LOCKING DEVICE

FIG. 1A

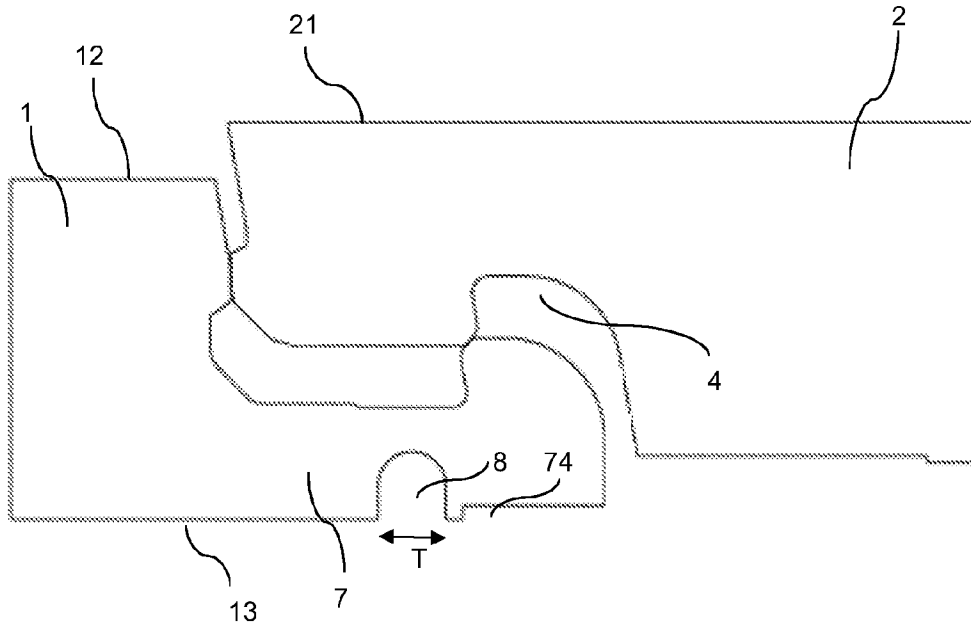

(57) **Abrégé/Abstract:**

A set of panels includes first and second panels, and a mechanical locking device for locking by vertical relative displacement of the panels. A locking strip (7) extends from a first edge (11) of the first panel in a direction parallel to first and second panel surfaces of the first panel (12,13). The locking strip (7) includes a locking element (3) configured to cooperate with a locking groove (4) at a second edge (21) of the second panel (2) for locking in a direction parallel to the first panel surface (12). Opposite edges respectively include cooperating tongue and tongue groove for vertical locking. The locking strip (7) includes a flexing groove (8) extending from the second locking strip surface (73) into the locking strip (7), to increase a flexibility of the locking strip during the assembly.

(12) INTERNATIONAL APPLICATION PUBLISHED UNDER THE PATENT COOPERATION TREATY (PCT)

(19) World Intellectual Property
Organization

International Bureau

(43) International Publication Date
01 April 2021 (01.04.2021)(10) International Publication Number
WO 2021/059179 A1(51) International Patent Classification:
E04F 15/02 (2006.01)(21) International Application Number:
PCT/IB2020/058925(22) International Filing Date:
24 September 2020 (24.09.2020)

(25) Filing Language: English

(26) Publication Language: English

(30) Priority Data:
1951085-8 25 September 2019 (25.09.2019) SE(71) Applicant: **VÄLINGE INNOVATION AB** [SE/SE];
Prästavägen 513, SE-263 64 Viken (SE).(72) Inventor: **BOO, Christian**; Tvärgatan 8, SE-268 77
Kågeröd (SE).(74) Agent: **ENGSTRAND, Ola**; Välinge Innovation AB, Präst-
tavägen 513, SE-263 65 Viken (SE).(81) Designated States (*unless otherwise indicated, for every
kind of national protection available*): AE, AG, AL, AM,AO, AT, AU, AZ, BA, BB, BG, BH, BN, BR, BW, BY, BZ,
CA, CH, CL, CN, CO, CR, CU, CZ, DE, DJ, DK, DM, DO,
DZ, EC, EE, EG, ES, FI, GB, GD, GE, GH, GM, GT, HN,
HR, HU, ID, IL, IN, IR, IS, IT, JO, JP, KE, KG, KH, KN,
KP, KR, KW, KZ, LA, LC, LK, LR, LS, LU, LY, MA, MD,
ME, MG, MK, MN, MW, MX, MY, MZ, NA, NG, NI, NO,
NZ, OM, PA, PE, PG, PH, PL, PT, QA, RO, RS, RU, RW,
SA, SC, SD, SE, SG, SK, SL, ST, SV, SY, TH, TJ, TM, TN,
TR, TT, TZ, UA, UG, US, UZ, VC, VN, WS, ZA, ZM, ZW.(84) Designated States (*unless otherwise indicated, for every
kind of regional protection available*): ARIPO (BW, GH,
GM, KE, LR, LS, MW, MZ, NA, RW, SD, SL, ST, SZ, TZ,
UG, ZM, ZW), Eurasian (AM, AZ, BY, KG, KZ, RU, TJ,
TM), European (AL, AT, BE, BG, CH, CY, CZ, DE, DK,
EE, ES, FI, FR, GB, GR, HR, HU, IE, IS, IT, LT, LU, LV,
MC, MK, MT, NL, NO, PL, PT, RO, RS, SE, SI, SK, SM,
TR), OAPI (BF, BJ, CF, CG, CI, CM, GA, GN, GQ, GW,
KM, ML, MR, NE, SN, TD, TG).**Declarations under Rule 4.17:**— *as to applicant's entitlement to apply for and be granted a
patent (Rule 4.17(ii))*

(54) Title: PANEL WITH LOCKING DEVICE

FIG. 1A

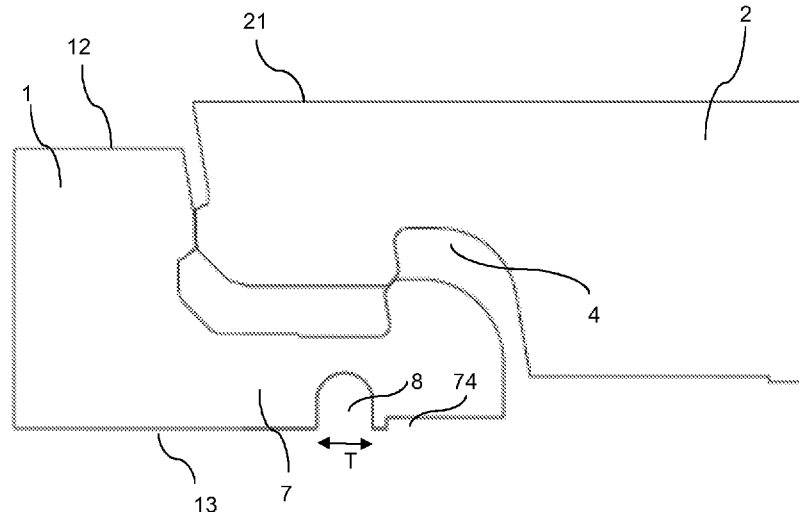

(57) **Abstract:** A set of panels includes first and second panels, and a mechanical locking device for locking by vertical relative displacement of the panels. A locking strip (7) extends from a first edge (11) of the first panel in a direction parallel to first and second panel surfaces of the first panel (12,13). The locking strip (7) includes a locking element (3) configured to cooperate with a locking groove (4) at a second edge (21) of the second panel (2) for locking in a direction parallel to the first panel surface (12). Opposite edges respectively include cooperating tongue and tongue groove for vertical locking. The locking strip (7) includes a flexing groove (8) extending from the second locking strip surface (73) into the locking strip (7), to increase a flexibility of the locking strip during the assembly.

[Continued on next page]



WO 2021/059179 A1

WO 2021/059179 A1 

Published:

— *with international search report (Art. 21(3))*

PANEL WITH LOCKING DEVICE

Technical field of the invention

Embodiments of the present invention relate to panels configured to be locked together
5 with a mechanical locking device. The panels may be floorboards to be locked together
to obtain a floor product.

Technical background

Panels are known that are configured to be assembled by a vertical displacement and
to be locked together in a vertical direction and in a horizontal direction. Such panels
10 are disclosed in e.g., WO 2018/063047. A tongue and groove connection locks a first
edge of a first panel to a second edge of the second panel. The first edge and the
second edge furthermore comprise a locking element configured to cooperate with a
locking groove for locking in the vertical direction and the horizontal direction.

The above description of various known aspects is the applicant's characterization of
15 such, and is not an admission that any of the above description is considered as prior
art.

Embodiments of the present invention address a need to provide panels that can be
easily assembled.

Summary of the invention

20 It is an object of certain aspects of the present invention to provide an improvement over
the above described techniques and known art.

A further object of at least certain aspects of the present invention is to facilitate
assembling of panels configured to be assembled by a vertical displacement or an
angling motion and locked together in the vertical direction and the horizontal direction.

25 A further object of at least certain aspects of the present invention is to facilitate
assembling of panels configured to be assembled in a way that reduces a force and
impact needed from a person when assembling the panels.

According to a first aspect there is provided a set of panels comprising a first panel, a second panel and a mechanical locking device for locking the first panel to the second panel, the mechanical locking device being configured for an assembly by a displacement of the second panel in relation to the first panel in a vertical direction to
5 obtain a locked position of the first panel and the second panel, wherein the first panel comprises a first edge, a first panel surface and a second panel surface, and the second panel comprises a second edge, wherein the mechanical locking device comprises a locking strip extending from the first edge in a direction parallel to the first and second panel surfaces, wherein the locking strip comprises a locking strip edge,
10 wherein the locking strip comprises a first locking strip surface extending in a direction substantially corresponding to the direction of the first panel surface of the first panel, wherein the locking strip comprises a second locking strip surface extending in a direction substantially corresponding to the direction of the second panel surface of the first panel, wherein the locking strip comprises a locking element configured to
15 cooperate with a locking groove at the second edge of the second panel for locking in a direction parallel to the first panel surface, wherein one of the first or second edge comprises a tongue configured to cooperate with a tongue groove at the other one of the first or second edge for locking in a vertical direction, wherein the locking strip comprises a flexing groove extending from the second locking strip surface into the
20 locking strip, and that the locking strip is configured to flex by varying a shape of the flexing groove during the assembly, thereby increasing a flexibility of the locking strip during the assembly.

According to an aspect the second locking strip surface comprises a recess extending from the locking strip edge to the flexing groove and parallel to the second panel
25 surface.

According to an aspect the recess has a length B and the locking strip edge is positioned at a distance Q from the first edge.

According to an aspect, the distance Q is measured between the outer edge of the locking strip edge and the intersection between the first edge and the first panel
30 surface.

According to an aspect a ratio between the length B of the recess and the distance Q is within the range of about 0.1 to about 0.9, preferably about 0.2 to about 0.6, more preferably about 0.35.

According to an aspect the recess has a height A within the range of 0.10 mm to about 0.50 mm, preferably about 0.15 mm to about 0.40 mm, more preferably about 0.20 mm to about 0.30 mm.

According to an aspect an opening of the flexing groove has a width T.

- 5 According to an aspect the width T of the opening of the flexing groove is within the range of about 1 mm to about 10 mm, preferably about 1.2 mm to about 2.5 mm, more preferably about 1.5 mm.

- 10 According to an aspect a distance D between the bottom of the flexing groove and the first locking strip surface is within the range of about 0.5 mm to about 5 mm, preferably about 1 mm to about 2.5 mm, more preferably about 1.5 mm.

According to an aspect the flexing groove extends at an angle α from the second panel surface.

According to an aspect the angle α is within the range of about 30° to about 100°, preferably about 60° to about 80°, more preferably about 70°.

- 15 According to an aspect the flexing groove is positioned at a distance Z from the locking strip edge of the locking strip.

According to an aspect a ratio between the distance Z and the distance Q is within the range of about 0 to about 0.5, preferably about 0.1 to about 0.3.

According to an aspect the flexing groove has a length L.

- 20 According to an aspect the first panel comprises a third edge and a fourth edge, the third edge being at a distance TL from the fourth edge.

According to an aspect the length L of the flexing groove extends from the third edge of the first panel to the fourth edge of the first panel.

- 25 According to an aspect the flexing groove has a fifth edge and a sixth edge, the fifth edge being positioned at a distance X from the third edge and the sixth edge being positioned at a distance X from the fourth edge.

According to an aspect the distance X is within the range of about 5 mm to about 30 mm, preferably about 10 mm to about 20 mm, more preferably about 15 mm.

According to an aspect a bottom of the flexing groove is essentially arch shaped.

According to an aspect a bottom of the flexing groove is essentially triangular.

According to an aspect a cross-sectional shape of the flexing groove is essentially rectangular or square.

5 According to an aspect the mechanical locking device is configured to lock the first panel and the second panel in a first direction parallel to the first panel surface and/or in a second direction perpendicular to the first panel surface.

According to an aspect the flexing groove is positioned at a distance Y from the first edge.

10 According to an aspect a ratio between the distance Y and the distance Q is within the range of about 0 to about 0.5, preferably about 0.1 to about 0.3.

According to an aspect a distance between the flexing groove and the locking element is shorter than a distance between the flexing groove and the first edge.

According to an aspect the second locking strip comprises a material of a core of the first panel.

15 According to an aspect the flexing groove and the recess are formed in the material of the core of the first panel.

According to an aspect the mechanical locking device is partly or completely formed in a core material of the first panel and the second panel.

20 According to an aspect the core of the first panel and/or of the second panel may be a wood-based core, preferably made of MDF, HDF, OSB, WPC, plywood or particleboard. The core may also be a plastic core comprising thermosetting plastic or thermoplastic e.g., vinyl, PVC, PU or PET. The plastic core may comprise fillers. The core may also be mineral based board which may comprise e.g., MgO.

The first panel and/or the second panel may also be of solid wood.

25 The first panel and/or the second panel may be provided with a decorative layer, such as a foil or a veneer, on one or more surfaces.

Brief description of the drawings

These and other aspects, features and advantages of which embodiments of the invention are capable of, will be apparent and elucidated from the following description of embodiments and aspects of the present invention, reference being made to the
5 accompanying drawings.

FIG. 1A shows a side view of an illustrative set in an unassembled state of an aspect of the invention.

FIG. 1B shows a side view of an illustrative set in an assembled state of an aspect of the invention.

10 FIG. 2A shows a side view of an illustrative first panel comprising a locking strip and a flexing groove of an aspect of the invention.

FIG. 2B shows a side view of an illustrative first panel comprising a locking strip and a flexing groove of an aspect of the invention.

15 FIG. 3A shows a side view of an illustrative first panel of an aspect of the invention, which comprises a locking strip and a flexing groove, and wherein the locking strip comprises a recess parallel to the second panel surface.

FIG. 3B shows a side view of an illustrative first panel of an aspect of the invention, which comprises a locking strip and a flexing groove, and wherein the locking strip comprises a recess parallel to the second panel surface.

20 FIG. 4A shows a side view of an illustrative set in an unassembled state of an aspect of the invention, wherein the first edge of the first panel comprises a tongue configured to cooperate with a tongue groove at the second edge of the second panel.

25 FIG. 4B shows a side view of an illustrative set in an assembled state of an aspect of the invention, wherein the first edge of the first panel comprises a tongue configured to cooperate with a tongue groove at the second edge of the second panel.

FIG. 5A shows a side view of an illustrative set in an unassembled state of an aspect of the invention, wherein the second edge of the second panel comprises a tongue configured to cooperate with a tongue groove at the first edge of the first panel.

FIG. 5B shows a side view of an illustrative set in an assembled state of an aspect of the invention, wherein the second edge of the second panel comprises a tongue configured to cooperate with a tongue groove at the first edge of the first panel.

5 FIG. 6A shows a side view of an illustrative first panel comprising a locking strip and a flexing groove of an aspect of the invention, which does not extend the whole length of the first panel, but which extends a distance X from the third edge of the first panel to a distance X from the fourth edge of the first panel.

10 FIG. 6B shows a view of an illustrative first panel comprising a locking strip and a flexing groove of an aspect of the invention, which extends over the whole length of the first panel.

FIG. 6C shows a view of an illustrative first panel comprising a locking strip and a flexing groove of an aspect of the invention, which does not extend over the whole length of the first panel, but which extends a distance X from the third edge of the first panel to a distance X from the fourth edge of the first panel.

15 FIGS. 7A-7B show an illustrative first panel comprising a locking strip and a flexing groove of an aspect of the invention, which extends throughout the whole distance from the second locking strip surface to the first locking strip surface. According to this aspect, the flexing groove does not extend over the whole length of the first panel, but extends a distance X from the third edge of the first panel to a distance X from the
20 fourth edge of the first panel.

FIGS. 8A-8B show an illustrative embodiment of a first panel comprising a locking strip and a flexing groove of an aspect of the invention, where the flexing groove may extend throughout the whole distance from the second locking strip surface to the first locking strip surface, but does not extend the whole length of the first panel. According
25 to this aspect, the flexing groove is not continuous, but is divided into two or more grooves running in line with a space between them. A first flexing groove extends a distance X from the third edge of the first panel and a last flexing groove extends a distance X from the fourth edge of the first panel.

30 FIG. 9 shows a side view of an illustrative first panel of an aspect of the invention. The first panel comprises a locking strip, a flexing groove and a recess, where the second locking strip surface and thus the recess, do not run parallel to the second panel surface, but at an angle β from the second panel surface.

Detailed description

Specific embodiments of the invention will now be described with reference to the accompanying drawings. This invention may, however, be embodied in many different forms and should not be construed as limited to the embodiments set forth herein; rather, these embodiments are provided so that this disclosure will be thorough and complete, and will fully convey the scope of the invention to those skilled in the art. The terminology used in the detailed description of the embodiments illustrated in the accompanying drawings is not intended to be limiting of the invention. In the drawings, like numbers refer to like elements.

10 The terminology used herein is for the purpose of describing particular aspects of the disclosure only, and is not intended to limit the disclosure. As used herein, the singular forms "a", "an" and "the" are intended to include the plural forms as well, unless the context clearly indicates otherwise.

15 It should be noted that the word "comprising" does not necessarily exclude the presence of other elements or steps than those listed and the words "a" or "an" preceding an element do not exclude the presence of a plurality of such elements. It should further be noted that any reference signs do not limit the scope of the claims, that the example aspects may be implemented at least in part by means of both hardware and software, and that several "means", "units" or "devices" may be
20 represented by the same item of hardware.

The different aspects, alternatives and embodiments of the invention disclosed herein can be combined with one or more of the other aspects, alternatives and embodiments described herein. Two or more aspects can be combined.

25 A first embodiment of the invention is shown, e.g., in FIGS. 1A-1B and 4A-5B, which show illustrative sets of panels comprising a first panel 1, a second panel 2 and a mechanical locking device for locking the first panel 1 to the second panel 2. The mechanical locking device is configured for an assembly by a displacement of the second panel 2 in relation to the first panel 1 in a vertical direction to obtain a locked position of the first panel 1 and the second panel 2. The first panel 1 comprises a first
30 edge 11, a first panel surface 12 and a second panel surface 13. The second panel 2 comprises a second edge 21. The mechanical locking device comprises a locking strip 7 extending from the first edge 11 in a direction parallel to the first and second panel

surfaces 12,13, wherein the locking strip 7 comprises a locking strip edge 71, wherein the locking strip 7 comprises a first locking strip surface 72 extending in a direction substantially corresponding to the direction of the first panel surface 12 of the first panel 1, wherein the locking strip 7 comprises a second locking strip surface 73
5 extending in a direction substantially corresponding to the direction of the second panel surface 13 of the first panel 1, and wherein the locking strip 7 comprises a locking element 3 configured to cooperate with a locking groove 4 at the second edge 21 of the second panel 2 for locking in a direction parallel to the first panel surface 12. By “substantially corresponding” it is meant that the noted directions may form an
10 angle within a range of +/- 10 degrees. One of the first or second edge 11,21 comprises a tongue 5 configured to cooperate with a tongue groove 6 at the other one of the first or second edge 11,21 for locking in a vertical direction. The set is characterized in that the locking strip 7 comprises a flexing groove 8 extending from the second locking strip surface 73 into the locking strip 7, and that the locking strip 7
15 is configured to flex by varying a shape of the flexing groove 8 during the assembly, thereby increasing a flexibility of the locking strip 7 during the assembly.

The increased flexibility of the locking strip 7 during assembly results in an increased distance between the first edge 11 and the locking element 3. This results in an easier assembly of the first 1 and second 2 panels.

20 In one embodiment, the locking strip 7 may comprise two or more flexing grooves 8 running parallel to each other.

The first panel 1 and the second panel 2 are preferably floorboards configured to be locked together to obtain a floor product.

An embodiment of a first panel 1 is shown in FIGS 1A-1B and 3A-3B, where the
25 second locking strip surface 73 comprises a recess 74 which extends from the locking strip edge 71 towards the flexing groove 8 and parallel to the second panel surface 13. This increases the flexing of the locking strip 7 during assembly of the first and second panels 1, 2 and makes the assembly easier. The recess 74 may have a length B.

The locking strip edge 71 may be positioned at a distance Q from the first edge 11 of
30 the first panel 1.

According to an aspect, the distance Q is to be measured between the outer edge of the locking strip edge 71 and the intersection between the first edge 11 and the first panel surface 12.

5 The ratio between the length B of the recess 74 and the distance Q may be within the range of about 0.1 to about 0.9, preferably about 0.2 to about 0.6, more preferably about 0.35. The ratios are great enough to enable an easy assembling and small enough to obtain sufficient locking strength. A ratio of 0.9 may provide an easier assembling and a ratio of 0.1 may provide a higher locking strength. The preferred ratio can depend on e.g. the material of the locking strip.

10 It shall be understood that the term "about" includes a margin for a measurement error which may be between 1^0 and 3^0 .

The recess 74 may have a height A within the range of 0.10 mm to about 0.50 mm, preferably about 0.15 mm to about 0.40 mm, more preferably about 0.20 mm to about 0.30 mm. The values are high enough to allow an easy assembling and low enough to
15 allow a sufficient locking strength. A height A of 0.5 mm may provide an easier assembling and a height A of 0.1 mm may provide a higher locking strength. The preferred value can depend on e.g. the material of the locking strip.

As shown for example in FIGS. 2A-2B, illustrative flexing grooves 8 in the first panel 1 are shown in FIGS. 1A-9. In one aspect the opening of the flexing groove 8 has a width
20 T. In one aspect the width T of the opening of the flexing groove 8 is within the range of about 1 mm to about 10 mm, preferably about 1.2 mm to about 2.5 mm, more preferably about 1.5 mm. The values are high enough to allow an easy assembling and low enough to allow a sufficient locking strength. A width T of 2.5 mm may provide an easier assembling and width T of 1 mm may provide a higher locking
25 strength. The preferred value can depend on e.g. the material of the locking strip.

The bottom 81 of the flexing groove 8 and the first locking strip surface 72 may be positioned at a distance D from each other. The distance D may be within the range of about 0.5 mm to about 5 mm, preferably about 1 mm to about 2.5 mm, more preferably about 1.5 mm. The values are low enough to allow an easy assembling and high
30 enough to allow a sufficient locking strength. A distance D of 1 mm may provide an easier assembling and distance D of 2.5 mm may provide a higher locking strength. The preferred value can depend on e.g. the material of the locking strip

In one aspect, if the thickness of the first panel 1, i.e., the distance between the first panel surface 12 and the second panel surface 13, is changed during production, e.g., from production of panels with a thickness of 8 mm to panels with a thickness of 12 mm, the distance D will still remain the same, and the tools required for the production will not have to be adjusted.

As shown for example in FIG. 2B, the flexing groove 8 may extend at an angle α from the second panel surface 13. The angle α is selected to optimize the flexing during assembly so that the assembly of the first and second panels 1,2 is easily facilitated. For example, one or several inner surface(s) of the flexing groove 8 may extend at the angle α from the second panel surface 13.

In one aspect the angle α is within the range of about 30° to about 100°, preferably about 60° to about 80°, more preferably about 70°.

It shall be understood that the term “about” includes a margin for a measurement error which may be between 1° and 3°.

The flexing groove 8 may be positioned at a distance Z from the locking strip edge 71 of the locking strip 7.

A ratio between the distance Z and the distance Q may be within the range of about 0 to about 0.5, preferably about 0.1 to about 0.3. The values are high enough to allow an easy assembling and the low enough to allow a sufficient locking strength. A ratio of 0.5 may provide an easier assembling and a ratio of 0.1 may provide a higher locking strength. The preferred ratio can depend on e.g. the material of the locking strip.

An aspect of the first panel 1 is shown in FIGS. 6B-6C, 7B and 8B, where the second panel surface 13 comprising the flexing groove 8 is shown.

As shown for example in FIGS. 6B, 6C, 7B and 8B, the first panel 1 may have a third edge 14 and a fourth edge 15, the third edge 14 being at a distance TL from the fourth edge 15.

The flexing groove 8 may have a length L, which in one aspect may extend from the third edge 14 to the fourth edge 15.

The flexing groove 8 may have a fifth 82 edge and a sixth 83 edge, where the fifth edge 82 may be positioned at a distance X from the third 14 edge and the sixth edge

83 may be positioned at a distance X from the fourth edge 15. The distance X may be within the range of about 5 mm to about 30 mm, preferably about 10 mm to about 20 mm, more preferably about 15 mm.

5 In one aspect shown in FIGS. 7A-7B, the flexing groove 8 extends throughout the whole distance from the second locking strip surface 73 to the first locking strip surface 72. According to this aspect, the flexing groove 8 does not extend over the whole distance TL of the first panel 1, but extends a distance X from the third edge 14 of the first panel 1 to a distance X from the fourth edge 15 of the first panel 1.

10 In one aspect shown in FIGS. 8A-8B, the flexing groove 8 do not extend throughout the whole distance from the second locking strip surface 73 to the first locking strip surface 72. According to this aspect, the flexing groove 8 does not extend the whole distance TL of the first panel 1. Further, the groove 8 does not have to be continuous, but may divided into two or more flexing grooves 8 running in line with a space between them.

15 In one aspect a first flexing groove 8, the flexing groove 8 closest to the third edge 14, may extend a distance X from the third edge 14 of the first panel 1, and another flexing groove 8, being the flexing groove 8 closest to the fourth edge 15, extends a distance X from the fourth edge 15 of the first panel 1. Thus, according to this aspect there is not only one flexing groove 8 on the first panel 1, but two or more flexing grooves 8, preferably on an essentially straight line parallel with the locking strip edge 71. The two
20 or more flexing grooves 8 are preferably separated a distance of 5 mm to 30 mm.

In one aspect the bottom 81 of the flexing groove 8 may be essentially arch shaped.

In one aspect the bottom 81 of the flexing groove 8 may be essentially triangular.

In one aspect the cross-sectional shape of the flexing groove 8 is essentially rectangular or square.

25 The first or second direction for locking of the first panel 1 to the second panel 2 may be parallel and/or perpendicular to the first panel surface 12.

In one aspect the flexing groove 8 is positioned at a distance Y from the first edge 11.

According to an aspect, the distance Y is to be measured between the flexing groove 8 and the intersection between the first edge 11 and the first panel surface 12.

A ratio between the distance Y and the distance Q may be within the range of about 0 to about 0.5, preferably about 0.1 to about 0.3. The values are low enough to allow an easy assembling and high enough to allow a sufficient locking strength. A ratio of e.g. 0.1 may provide an easier assembling and a ratio of e.g. 0.5 may provide a higher locking strength. The preferred ratio can depend on e.g. the material of the locking strip.

In one aspect the distance between the flexing groove 8 and the locking element 3 is shorter than the distance between the flexing groove 8 and the first edge 11.

The core of the first panel 1 and/or of the second panel 2 may be a wood-based core, preferably made of MDF, HDF, OSB, WPC, plywood or particleboard. The core may also be a plastic core comprising thermosetting plastic or thermoplastic e.g., vinyl, PVC, PU or PET. The plastic core may comprise fillers. The core may also be mineral based board which may comprise e.g., MgO.

The first panel 1 and/or the second panel 2 may also be of solid wood.

The locking strip 7 may comprises a material of a core of the first panel.

The flexing groove 8 and the recess 74 may be formed in the material of the core of the first panel.

The mechanical locking device may be partly or completely formed in a core material of the first panel and the second panel.

The first panel 1 and/or the second panel 2 may be provided with a decorative layer, such as a foil or a veneer, on one or more surfaces.

In one aspect, as shown in FIGS. 4A-4B, the first edge 11 of the first panel 1 comprises a tongue 5 and the second edge 21 of the second panel 2, opposite to the first edge 11 of the first panel 1, comprises a tongue groove 6. The tongue 5 on the first edge 11 is configured to cooperate with the tongue groove 6 on the second edge 21 for locking in a vertical direction. The second locking strip surface 73 may comprise a recess 74 which extends from the locking strip edge 71 towards the flexing groove 8. Figure 4A shows the first and second panels 1,2 according to this aspect in an unassembled state, while Figure 4B shows the first and second panels 1,2 according to this aspect in an assembled state.

In one aspect, as shown in FIGS. 5A-5B, the second edge 21 of the second panel 2 comprises a tongue 5 and first edge 11 of the first panel 1, opposite to the second edge

21 of the second panel 2, comprises a tongue groove 6. The tongue 5 on the second edge 21 is configured to cooperate with the tongue groove 6 on the first edge 11 for locking in a vertical direction. Figure 5A shows the first and second panels 1,2 according to this aspect in an unassembled state, while Figure 5B shows the first and second panels 1,2 according to this aspect in an assembled state.

In one aspect, as shown FIG. 9, the first panel comprises a locking strip, a flexing groove and a recess, wherein the second locking strip surface 73 (and thus the recess) do not run parallel to the second panel surface 13, but at an angle β from the second panel surface 13. The angle β may be in the range of about 0 to about 45°, or in the range of about 0 to about 20°, or in the range of about 0 to about 10°, or about 5°.

The first panel 1 and the second panel 2 may be of a rectangular shape.

The first panel 1 may comprise an edge opposite the first edge which is essentially identical to the second edge of the second panel 2.

The second panel 2 may comprise an edge opposite the second edge which is essentially identical to the first edge of the first panel 1.

The first edge and the second edge may be short edges of the first panel and the second panel.

The assembling may also comprise an angling motion along a long side of the first panel and/or the second panel.

Further embodiments of the invention are described below:

1. A set of panels comprising a first panel (1), a second panel (2) and a mechanical locking device for locking the first panel (1) to the second panel (2), the mechanical locking device being configured for an assembly by a displacement of the second panel (2) in relation to the first panel (1) in a vertical direction to obtain a locked position of the first panel (1) and the second panel (2), wherein the first panel (1) comprises a first edge (11), a first panel surface (12) and a second panel surface (13), and the second panel (2) comprises a second edge (21),

wherein the mechanical locking device comprises a locking strip (7) extending from the first edge (11) in a direction parallel to the first and second panel surfaces (12,13),

wherein the locking strip (7) comprises a locking strip edge (71),

wherein the locking strip (7) comprises a first locking strip surface (72) extending in a direction substantially corresponding to the direction of the first panel surface (12) of the first panel (1),

5 wherein the locking strip (7) comprises a second locking strip surface (73) extending in a direction substantially corresponding to the direction of the second panel surface (13) of the first panel (1),

wherein the locking strip (7) comprises a locking element (3) configured to cooperate with a locking groove (4) at the second edge (21) of the second panel (2) for locking in a direction parallel to the first panel surface (12),

10 wherein one of the first or second edge (11,21) comprises a tongue (5) configured to cooperate with a tongue groove (6) at the other one of the first or second edge (11,21) for locking in a vertical direction, and

wherein the locking strip (7) comprises a flexing groove (8) extending from the second locking strip surface (73) into the locking strip (7), and wherein the locking strip
15 (7) is configured to flex by varying a shape of the flexing groove (8) during the assembly, thereby increasing a flexibility of the locking strip (7) during the assembly.

2. The set of panels as described in embodiment 1, wherein the second locking strip surface (73) comprises a recess (74) extending from the locking strip edge (71) towards the flexing groove (8) and parallel to the second panel surface (13).

20 3. The set of panels as described in any one of the previous embodiments, wherein the recess (74) has a length B and wherein locking strip edge (71) is positioned at a distance Q from the first edge (11).

4. The set of panels as described in embodiment 3, wherein a ratio between the length B of the recess (74) and the distance Q is within the range of about 0.1 to about 0.9,
25 preferably about 0.2 to about 0.6, more preferably about 0.35.

5. The set of panels as described in any one of embodiments 2 to 4, wherein the recess (74) has a height A within the range of about 0.10 mm to about 0.50 mm, preferably about 0.15 mm to about 0.40 mm, more preferably about 0.20 mm to about 0.30 mm.

6. The set of panels as described in any one of the previous embodiments, wherein an
30 opening of the flexing groove (8) has a width T.

7. The set of panels as described in embodiment 6, wherein the width T of the opening of the flexing groove (8) is within the range of about 1 mm to about 10 mm, preferably about 1.2 mm to about 2.5 mm, more preferably about 1.5 mm.

8. The set of panels as described in any one of the previous embodiments, wherein a distance D between the bottom (81) of the flexing groove (8) and the first locking strip surface (72) is within the range of about 0.5 mm to about 5 mm, preferably about 1 mm to about 2.5 mm, more preferably about 1.5 mm.
- 5 9. The set of panels as described in any one of the previous embodiments, wherein the flexing groove (8) extends at an angle α from the second panel surface (13).
10. The set of panels as described in embodiment 9, wherein the angle α is within the range of about 30° to about 100° , preferably about 60° to about 80° , more preferably about 70° .
- 10 11. The set of panels as described in any one of the previous embodiments, wherein the flexing groove (8) is positioned at a distance Z from the locking strip edge (71) of the locking strip (7).
12. The set of panels as described in embodiment 11, wherein a ratio between the distance Z and the distance Q is within the range about 0 to about 0.5, preferably about
15 0.1 to about 0.3..
13. The set of panels as described in any one of the previous embodiments, wherein the flexing groove (8) has a length L .
14. The set of panels as described in any one of the previous embodiments, wherein the first panel (1) comprises a third edge (14) and a fourth edge (15), the third edge (14)
20 being at a distance TL from the fourth edge (15).
15. The set of panels as described in embodiment 14, wherein the length L of the flexing groove (8) extends from the third edge (14) of the first panel (1) to the fourth edge (15) of the first panel (1).
16. The set of panels as described in any one of embodiments 1 to 14, wherein the
25 flexing groove (8) has a fifth (82) edge and a sixth (83) edge, the fifth edge (82) being positioned at a distance X from the third (14) edge and the sixth edge (83) being positioned at a distance X from the fourth edge (15).
17. The set of panels as described in embodiment 16, wherein the distance X is within the range of about 5 mm to about 30 mm, preferably about 10 mm to about 20 mm, more
30 preferably about 15 mm.
18. The set of panels as described in any one of the previous embodiments, wherein a bottom (81) of the flexing groove (8) is essentially arch shaped.
19. The set of panels as described in any one of embodiments 1 to 17, wherein a bottom (81) of the flexing groove (8) is essentially triangular.

20. The set of panels as described in any one of embodiments 1 to 17, wherein a cross-sectional shape of the flexing groove (8) is essentially rectangular or square.

21. The set of panels as described in any one of the previous embodiments, wherein the mechanical locking device is configured to lock the first panel 1 and the second panel 2
5 in a first direction parallel to the first panel surface 12 and/or in a second direction perpendicular to the first panel surface 12.

22. The set of panels as described in any one of the previous embodiments, wherein the flexing groove (8) is positioned at a distance Y from the first edge (11).

23. The set of panels as described in embodiment 22, wherein a ratio between the
10 distance Y and the distance Q is within the range of about 0 to about 0.5, preferably about 0.1 to about 0.3.

24. The set of panels as described in any one of the previous embodiments, wherein a distance between the flexing groove (8) and the locking element (3) is shorter than a distance between the flexing groove (8) and the first edge (11).

15 25. The set of panels as claimed in any one of the previous embodiments, wherein the second locking strip (7) comprises a material of a core of the first panel, and wherein the flexing groove (8) and the recess (74) are formed in the material of the core of the first panel (1).

CLAIMS

1. A set of panels comprising a first panel (1), a second panel (2) and a mechanical locking device for locking the first panel (1) to the second panel (2), the mechanical locking device being configured for an assembly by a displacement of the second panel (2) in relation to the first panel (1) in a vertical direction to obtain a locked position of the first panel (1) and the second panel (2), wherein the first panel (1) comprises a first edge (11), a first panel surface (12) and a second panel surface (13), and the second panel (2) comprises a second edge (21),
- 5
- 10 wherein the mechanical locking device comprises a locking strip (7) extending from the first edge (11) in a direction parallel to the first and second panel surfaces (12,13),
- wherein the locking strip (7) comprises a locking strip edge (71),
- wherein the locking strip (7) comprises a first locking strip surface (72) extending
- 15 in a direction substantially corresponding to the direction of the first panel surface (12) of the first panel (1),
- wherein the locking strip (7) comprises a second locking strip surface (73) extending in a direction substantially corresponding to the direction of the second panel surface (13) of the first panel (1),
- 20 wherein the locking strip (7) comprises a locking element (3) configured to cooperate with a locking groove (4) at the second edge (21) of the second panel (2) for locking in a direction parallel to the first panel surface (12),
- wherein one of the first or second edge (11,21) comprises a tongue (5) configured to cooperate with a tongue groove (6) at the other one of the first or second edge (11,21)
- 25 for locking in a vertical direction, **characterised in**
- that the locking strip (7) comprises a flexing groove (8) extending from the second locking strip surface (73) into the locking strip (7), and that the locking strip is configured to flex by varying a shape of the flexing groove (8) is configured to increase a flexibility of the locking strip (7) during the assembly, and
- 30 that the second locking strip surface (73) comprises a recess (74) extending from the locking strip edge (71) towards the flexing groove (8) and parallel to the second panel surface (13).

2. The set of panels as claimed in claim 1, wherein the second locking strip (7) comprises a material of a core of the first panel, and wherein the flexing groove (8) and the recess (74) are formed in the material of the core of the first panel (1).
- 5 3. The set of panels as claimed in any one of the previous claims, wherein the recess (74) has a length B and wherein locking strip edge (71) is positioned at a distance Q from the first edge (11), and a ratio between the length B of the recess and the distance Q is within the range of about 0.1 to about 0.9.
- 10 4. The set of panels as claimed in claim 3, wherein a ratio between the length B of the recess (74) and the distance Q is within the range of about 0.2 to about 0.6, more preferably about 0.35.
5. The set of panels as claimed in any one of claims 2 to 4, wherein the recess (74) has
15 a height A within the range of about 0.10 mm to about 0.50 mm, preferably about 0.15 mm to about 0.40 mm, more preferably about 0.20 mm to about 0.30 mm.
6. The set of panels as claimed in any one of the previous claims, wherein an opening of the flexing groove (8) has a width T, wherein the width T of the opening of the flexing
20 groove is within the range of about 1 mm to about 10 mm.
7. The set of panels as claimed in claim 6, wherein the width T of the opening of the flexing groove (8) is within the range of about 1.2 mm to about 2.5 mm, more preferably about 1.5 mm.
25
8. The set of panels as claimed in any one of the previous claims, wherein a distance D between a bottom (81) of the flexing groove (8) and the first locking strip surface (72) is within the range of about 0.5 mm to about 5 mm, preferably about 1 mm to about 2.5 mm, more preferably about 1.5 mm.
30
9. The set of panels as claimed in any one of the previous claims, wherein at least one inner surface of the flexing groove (8) extends at an angle α from the second panel surface (13), wherein the angle α is within the range of about 30° to about 100°.

10. The set of panels as claimed in claim 9, wherein the angle α is within the range of about 60° to about 80°, more preferably about 70°.

11. The set of panels as claimed in any one of the previous claims, wherein the flexing groove (8) is positioned at a distance Z from the locking strip edge (71) of the locking strip (7), and a ratio between the distance Z and the distance Q is within the range of about 0 to about 0.5.

12. The set of panels as claimed in claim 11, wherein a ratio between the distance Z and the distance Q is within the range of about 0.1 to about 1.3.

13. The set of panels as claimed in any one of the previous claims, wherein the first panel (1) comprises a third edge (14) and a fourth edge (15), the third edge (14) being at a distance TL from the fourth edge (15).

14. The set of panels as claimed in claim 13, wherein the flexing groove has a length L, and wherein the length L of the flexing groove (8) extends from the third edge (14) of the first panel (1) to the fourth edge (15) of the first panel (1).

15. The set of panels as claimed in any one of claims 1 to 14, wherein the flexing groove (8) has a fifth (82) edge and a sixth (83) edge, the fifth edge (82) being positioned at a distance X from the third (14) edge and the sixth edge (83) being positioned at a distance X from the fourth edge (15).

16. The set of panels as claimed in claim 15, wherein the distance X is within the range of about 5 mm to about 30 mm, preferably about 10 mm to about 20 mm, more preferably about 15 mm.

17. The set of panels as claimed in any one of the previous claims, wherein a bottom (81) of the flexing groove (8) is essentially arch shaped.

18. The set of panels as claimed in any one of claims 1 to 17, wherein a bottom (81) of the flexing groove (8) is essentially triangular.

19. The set of panels as claimed in any one of claims 1 to 17, wherein a cross-sectional shape of the flexing groove (8) is essentially rectangular or square.

20. The set of panels as claimed in any one of the previous claims, wherein the
5 mechanical locking device is configured to lock the first panel and the second panel in a first direction parallel to the first panel surface and/or in a second direction perpendicular to the first panel surface.

21. The set of panels as claimed in any one of the previous claims, wherein the flexing
10 groove (8) is positioned at a distance Y from the first edge (11), wherein a ratio between the distance Y and the distance Q is within the range of about 0 to about 0.5.

22. The set of panels as claimed in claim 21, wherein a ratio between the distance Y and the distance Q is within the range of about 0.1 to about 0.3.

15 23. The set of panels as claimed in any one of the previous claims, wherein a distance between the flexing groove (8) and the locking element (3) is shorter than a distance between the flexing groove (8) and the first edge (11).

FIG. 1A

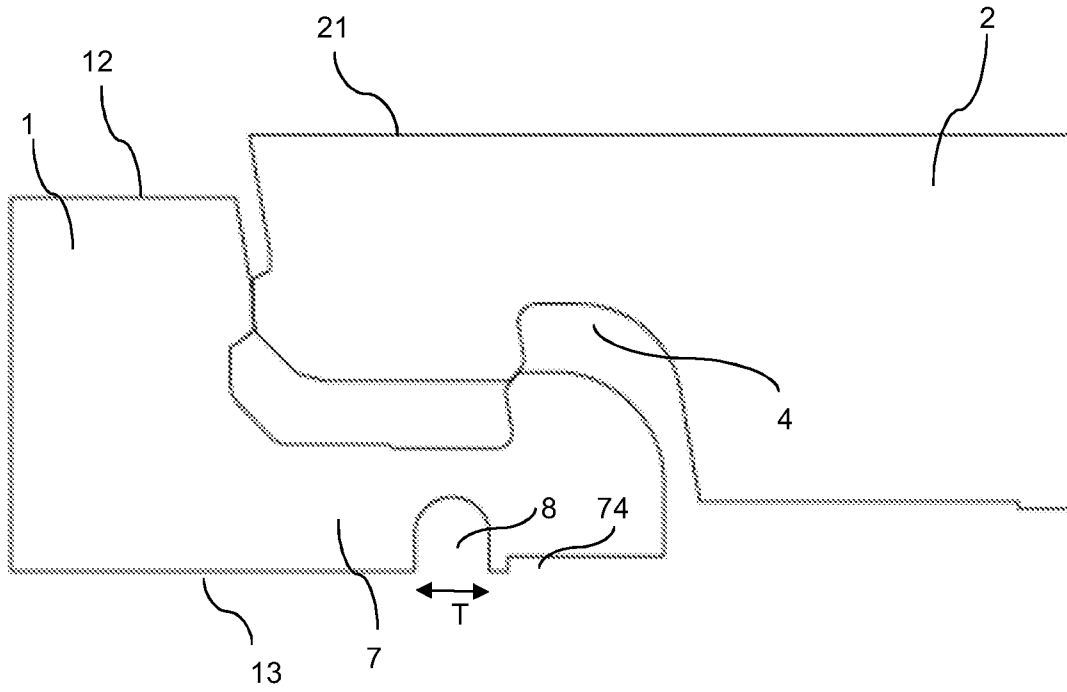

FIG. 1B

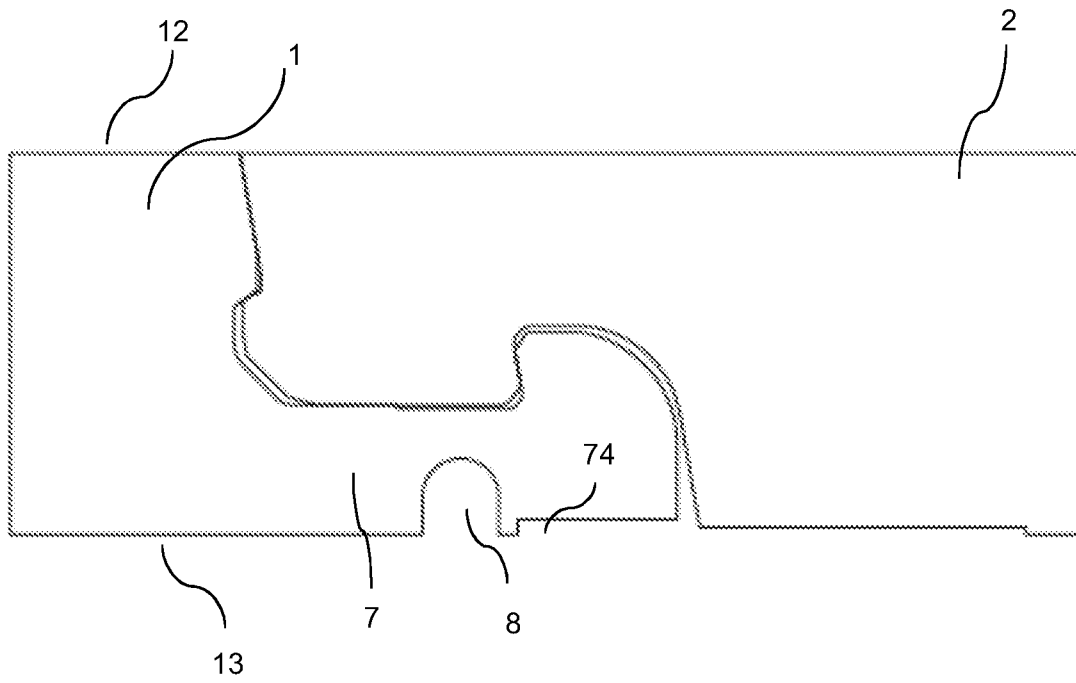

FIG. 2A

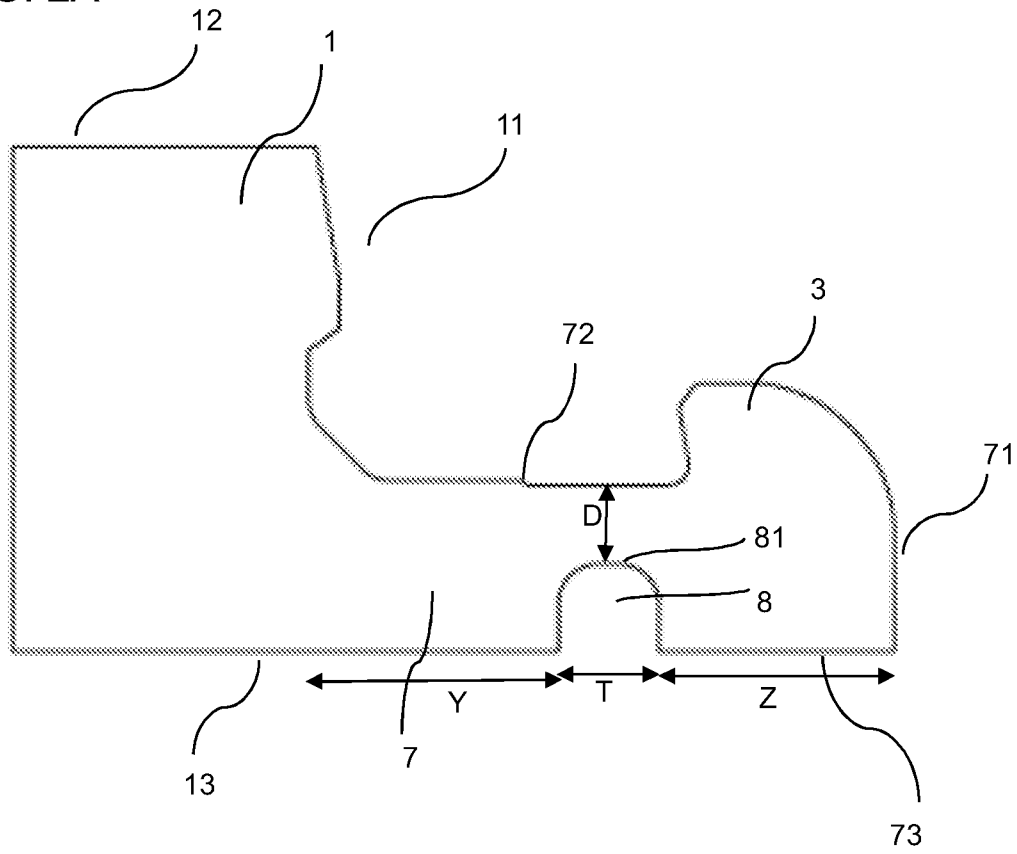

FIG. 2B

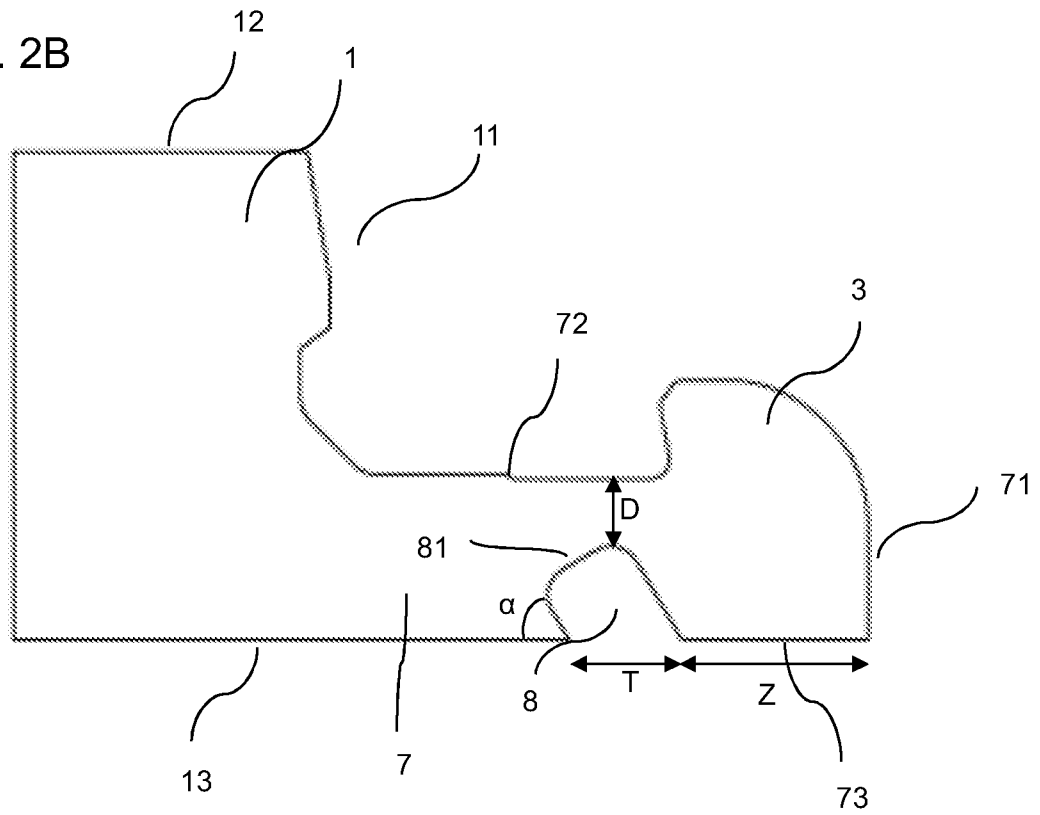

FIG. 3A

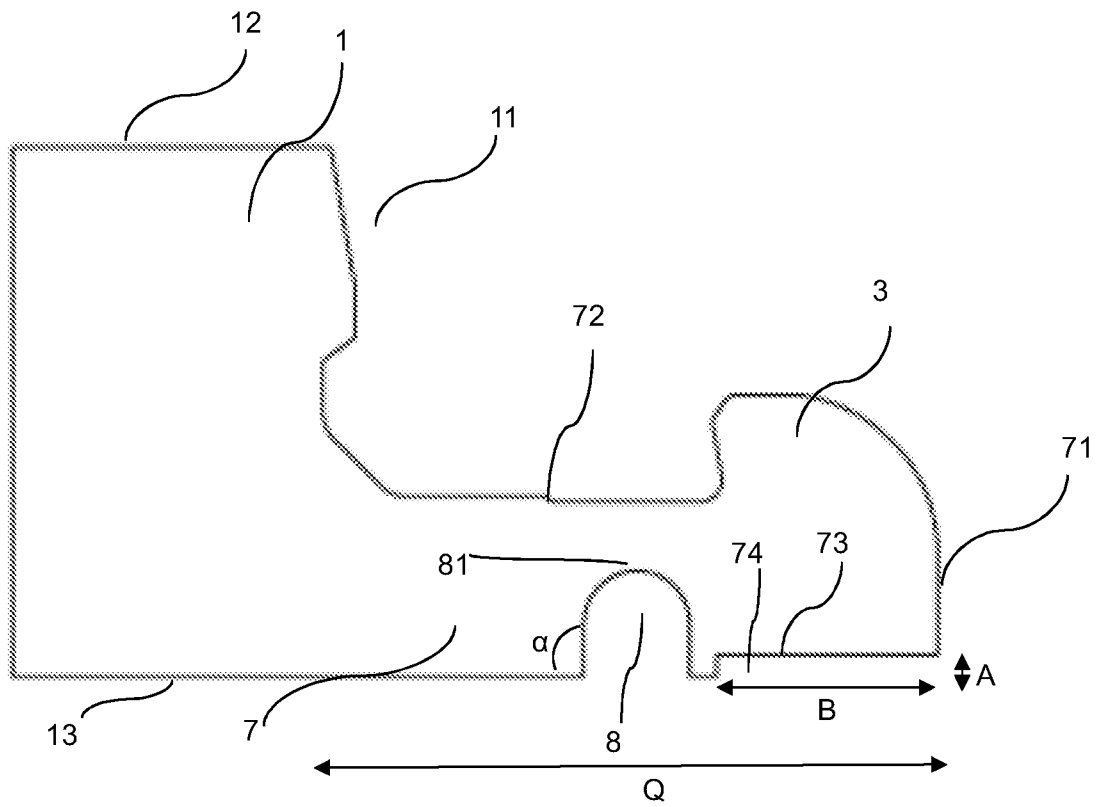

FIG. 3B

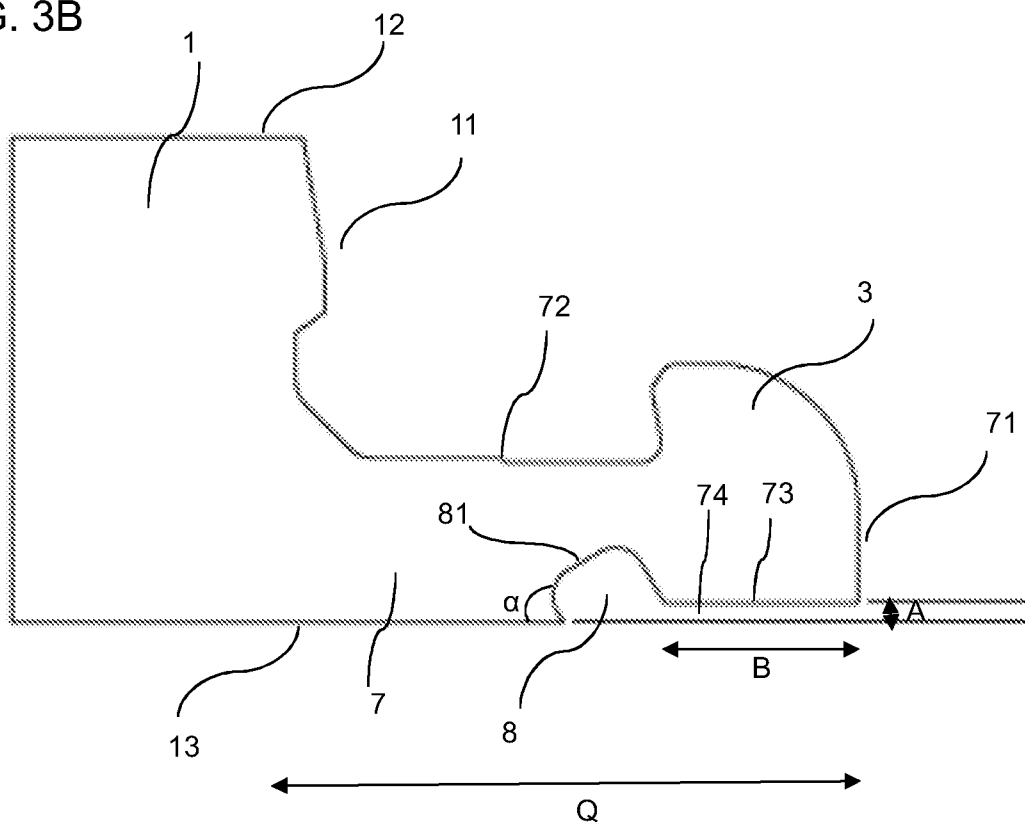

FIG. 4A

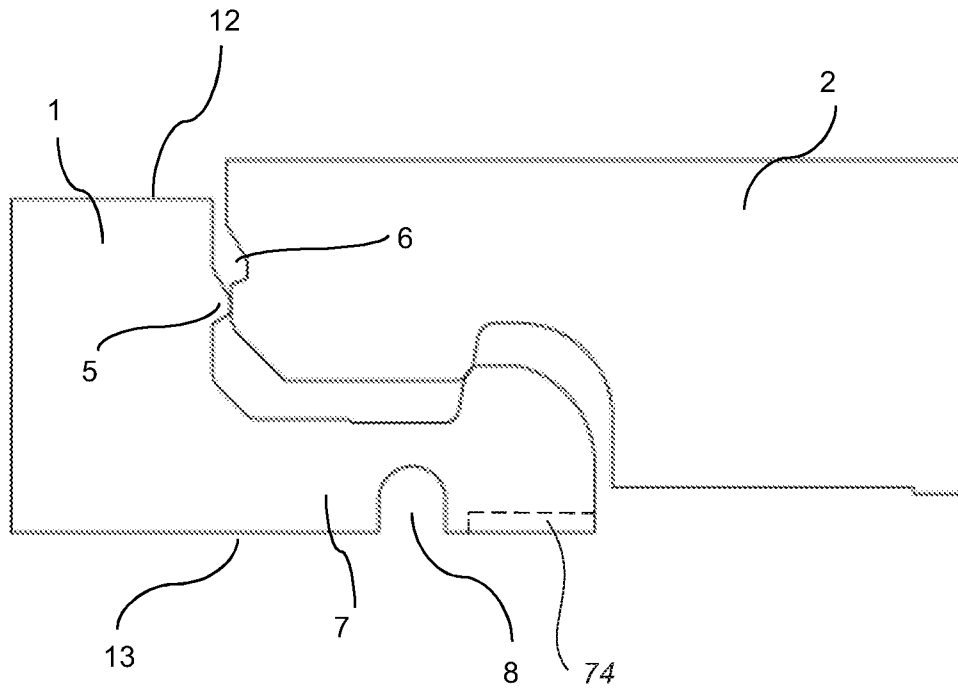

FIG. 4B

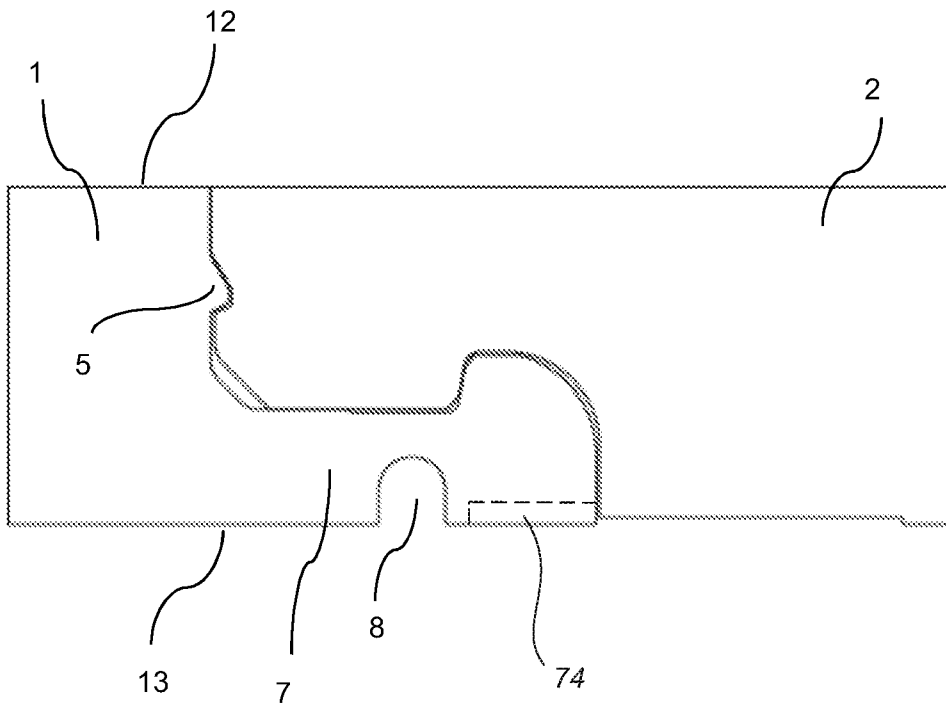

FIG. 6A

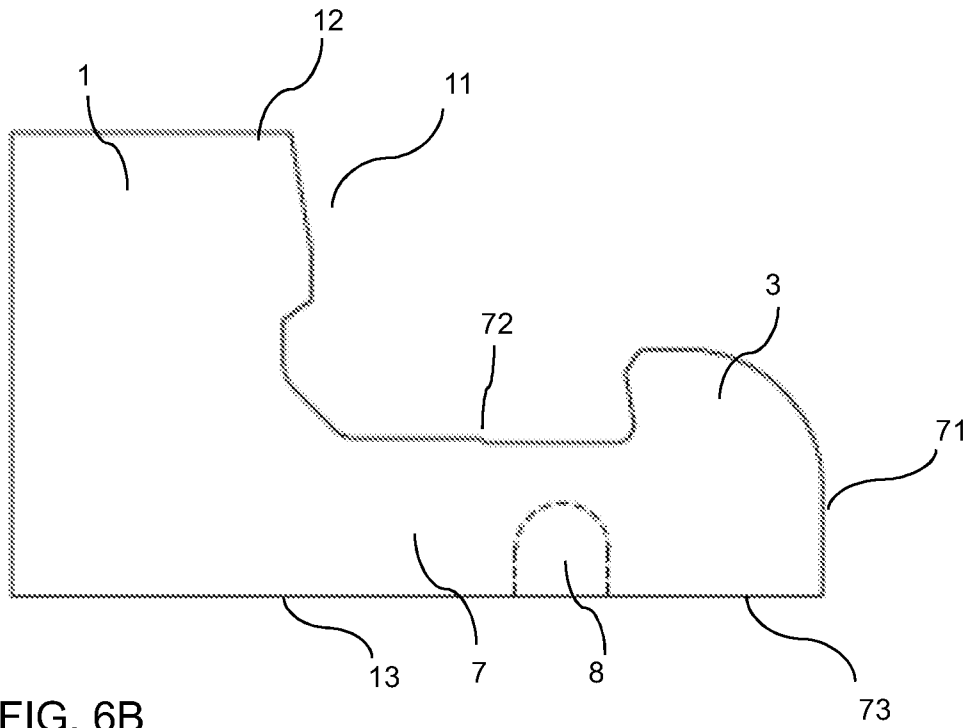

FIG. 6B

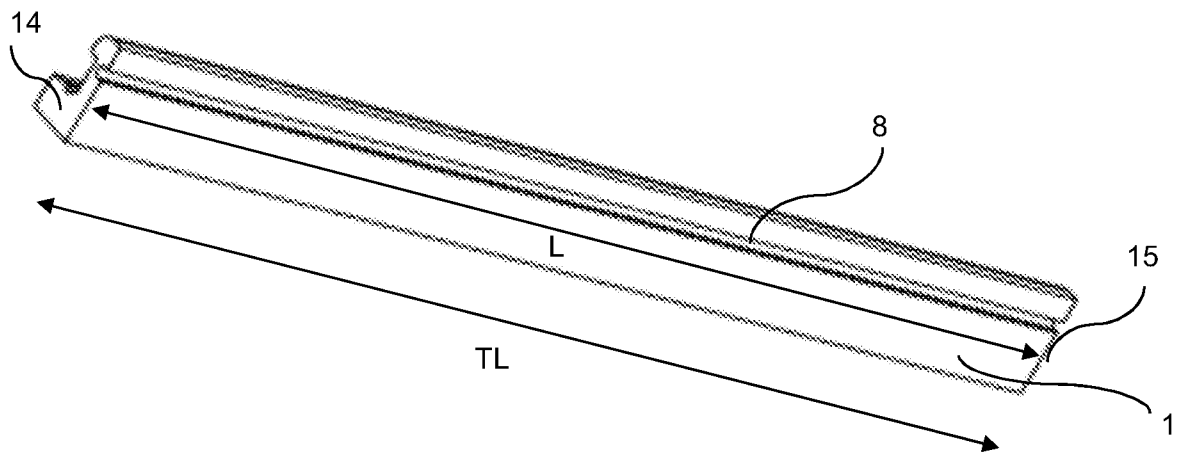

FIG. 6C

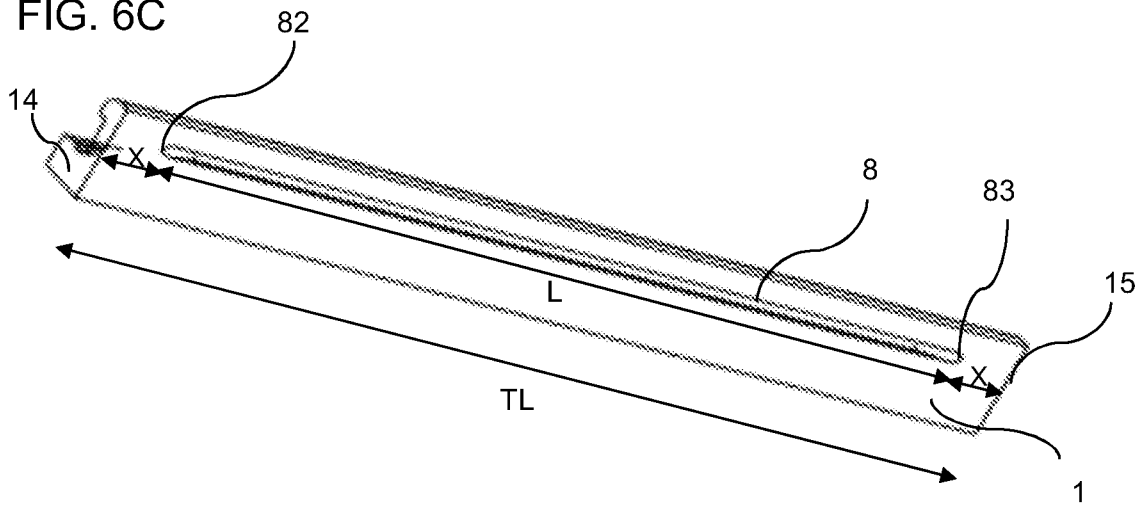

FIG. 7A

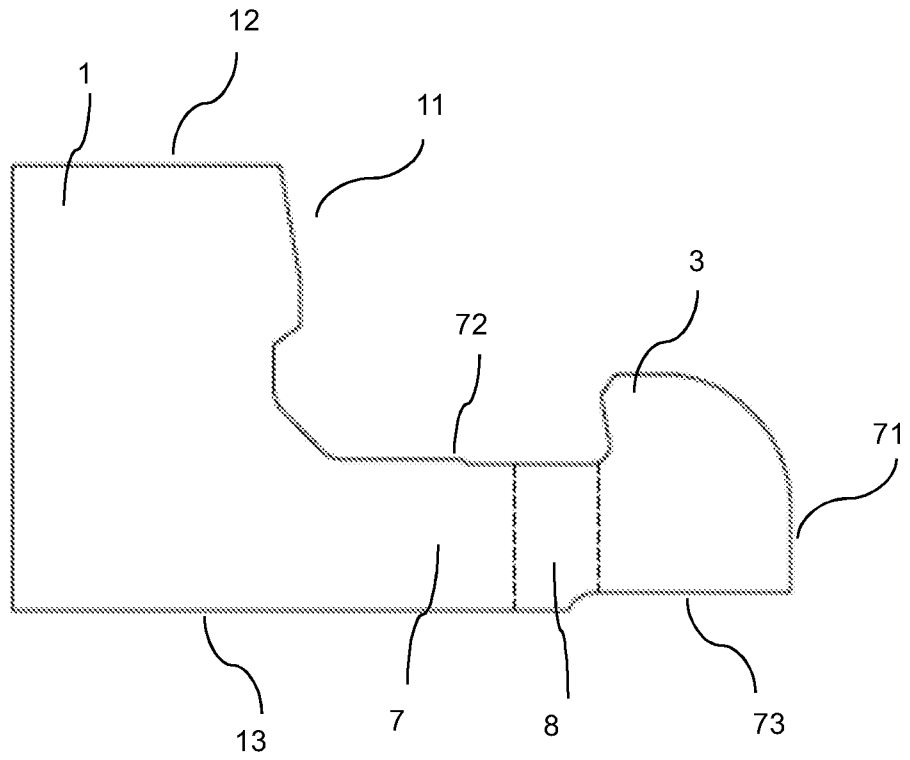

FIG. 7B

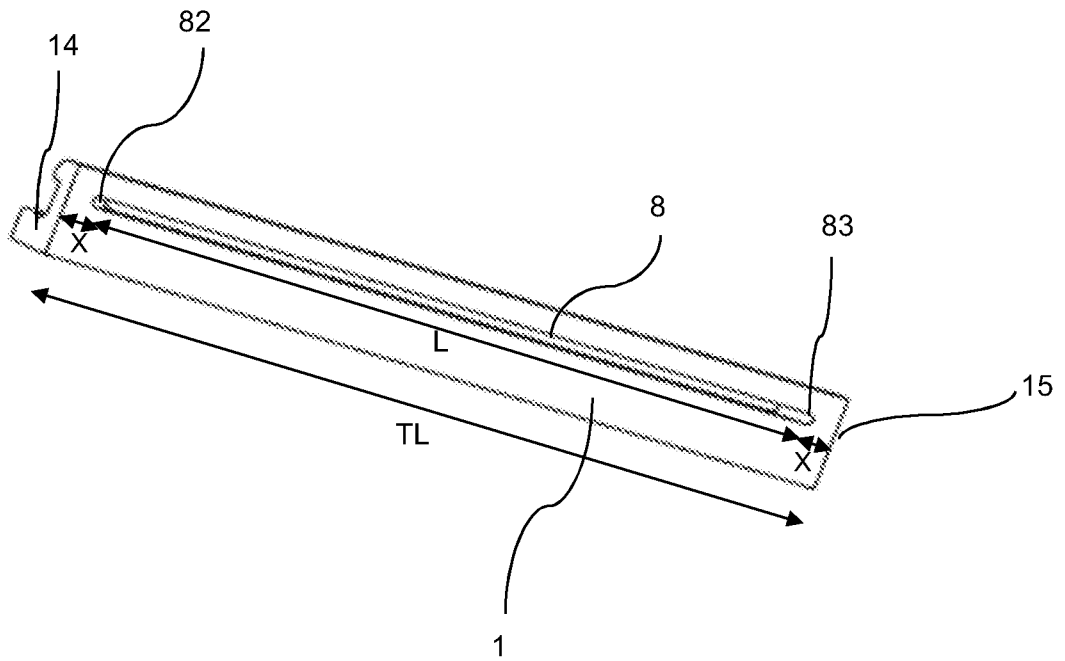

FIG. 8A

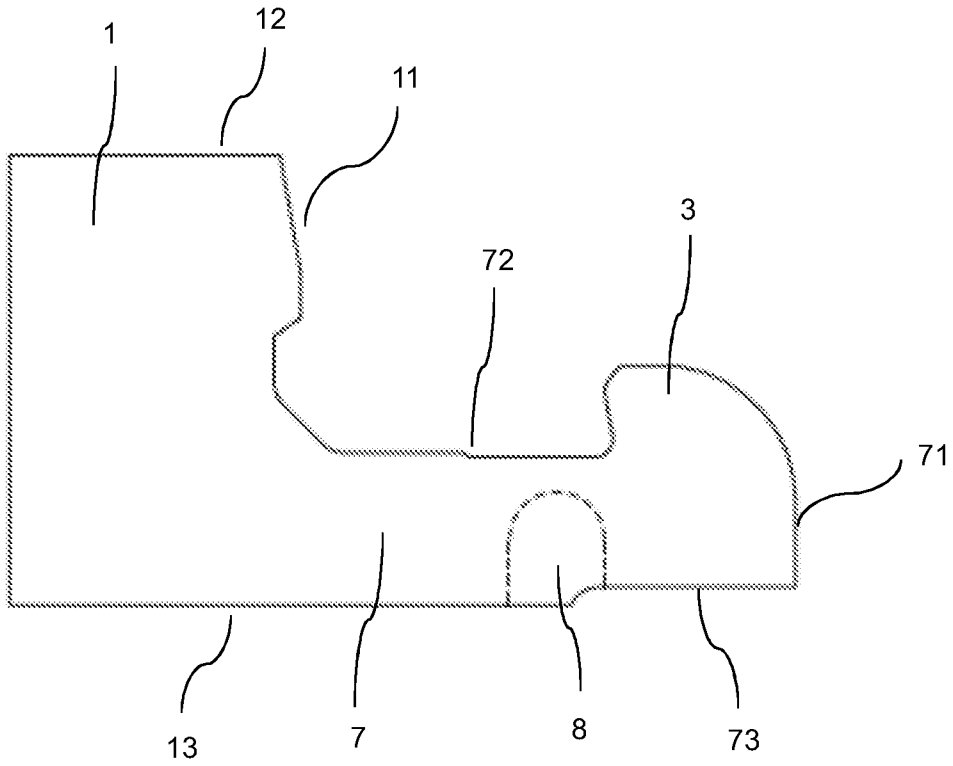

FIG. 8B

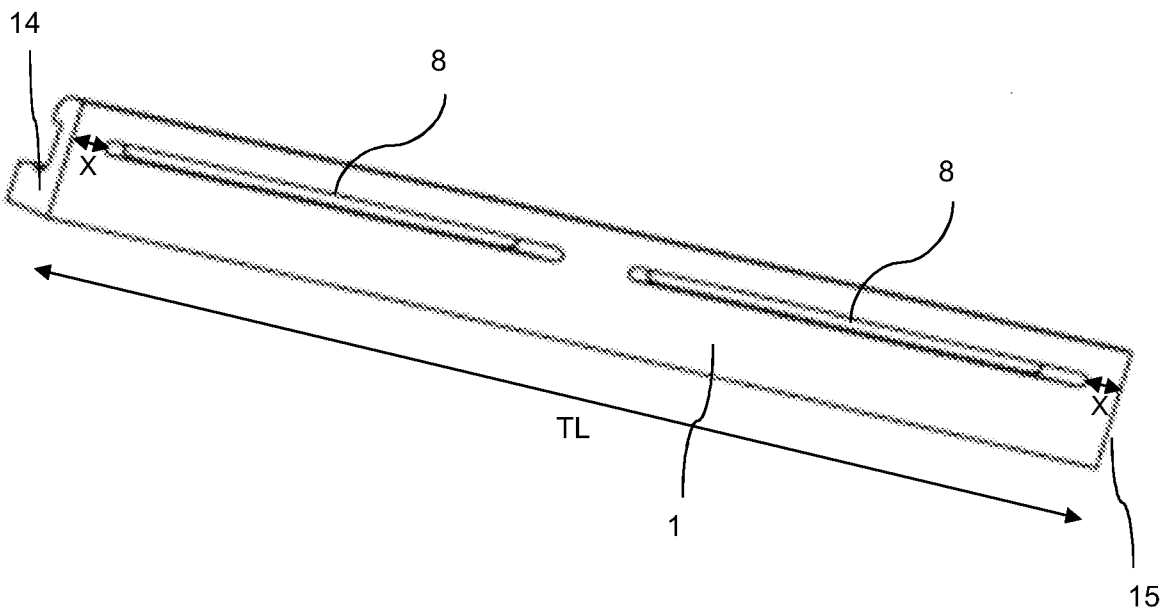

FIG. 9

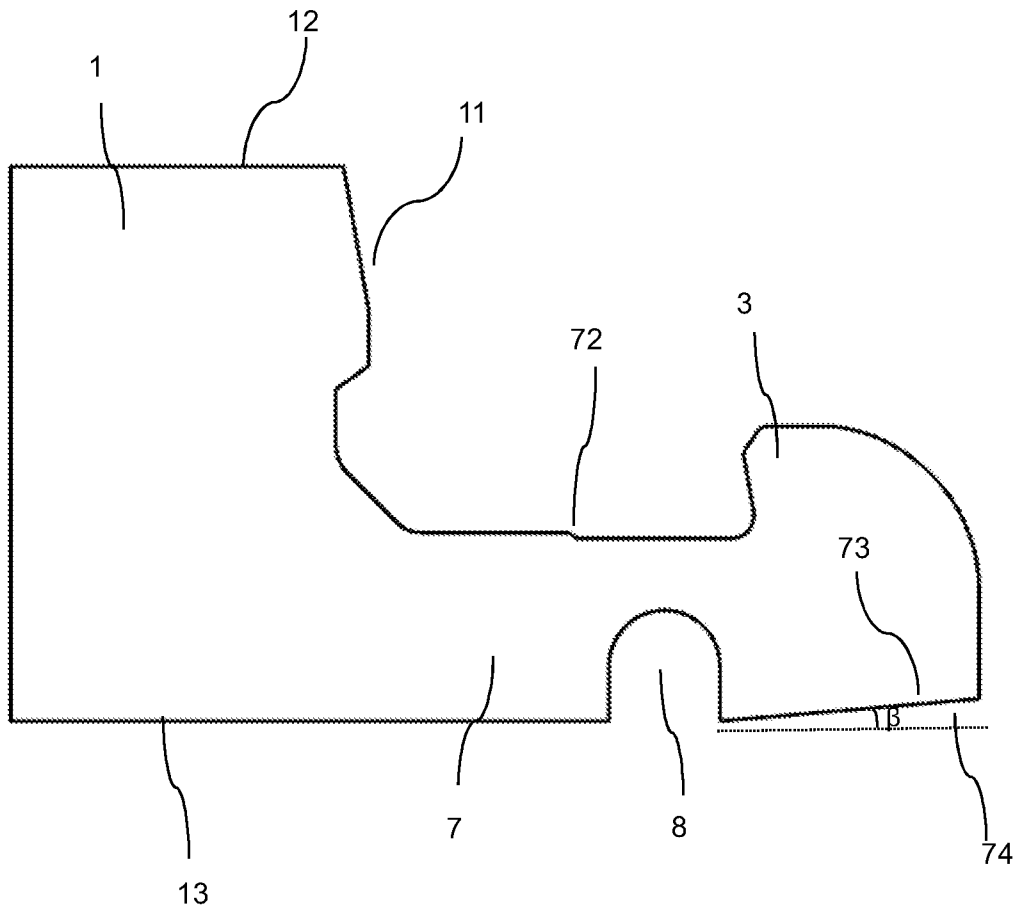

FIG. 1A

