

July 7, 1964

F. M. AIMES

3,139,865

STABILIZER SUPPORT FOR MARKING DEVICES

Filed May 7, 1963

*Fig. 1.*

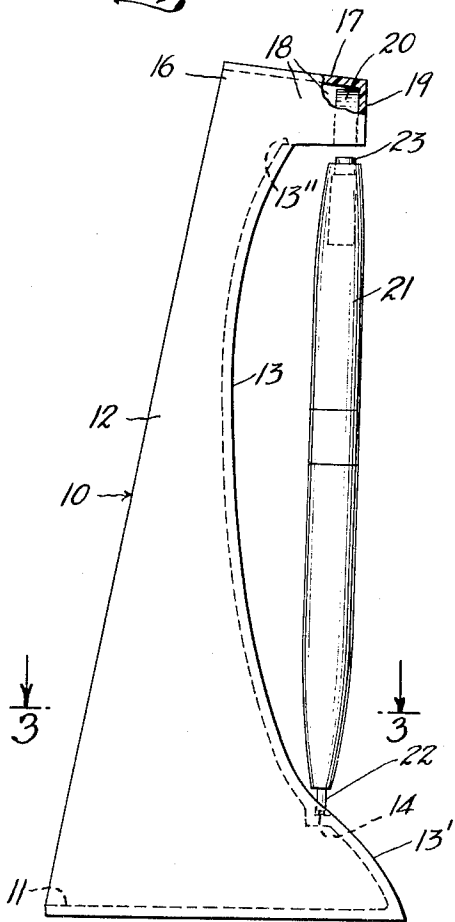

*Fig. 2.*

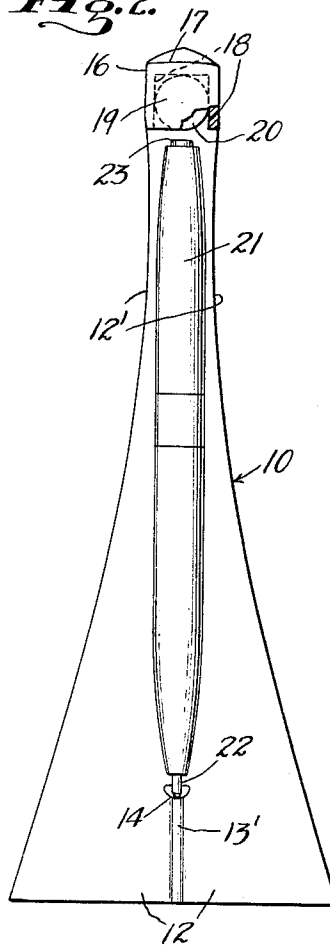

*Fig. 3.*

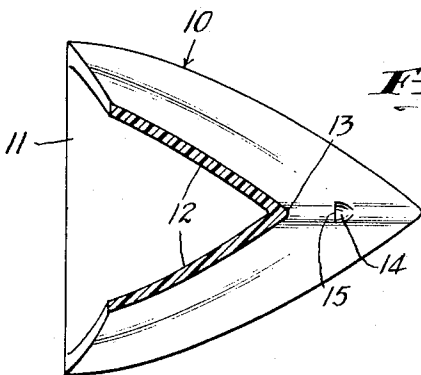

INVENTOR.  
FRANCIS M. AIMES  
BY  
*Howard E. Thompson*  
ATTORNEY

1

3,139,865

**STABILIZER SUPPORT FOR MARKING DEVICES**

Francis M. Aimes, Chatham, N.Y.  
 Filed May 7, 1963, Ser. No. 278,632  
 3 Claims. (Cl. 120-108)

This invention relates to a support for maintaining marking devices, such as pens, pencils and the like, in a perpendicular stabilized position through the medium of the magnetic flux of a magnet supported in connection with the device. More particularly, the invention deals with a device of the character described having, at its base, a platform for receiving and supporting the marking end of the implement, said platform being in perpendicular alinement with the magnet supported in the device.

Still more particularly, the invention deals in a device of the character described employing a relatively wide base, preferably of triangular formation, and a contracted narrow magnet supporting top, the body portion of the device between the upper and lower ends being of a contour giving free access to an implement supported in the device for removal and replacement of the implement with respect to the device.

The novel features of the invention will be best understood from the following description, when taken together with the accompanying drawing, in which certain embodiments of the invention are disclosed and, in which, the separate parts are designated by suitable reference characters in each of the views and, in which:

FIG. 1 is a diagrammatic side view of a device made according to my invention, illustrating a writing implement supported thereon in stabilized position, part of the construction being broken away and in section.

FIG. 2 is a front view of the device, as seen in FIG. 1, with part of the construction broken away and in section; and

FIG. 3 is a section substantially on the line 3-3 of FIG. 1, omitting the writing implement.

In illustrating one adaptation and use of my invention, I have shown at 10 an implement supporting device, comprising a rather large or wide substantially triangular base 11, having upwardly contracted and contoured side walls 12, note FIG. 3, so as to form a relatively narrow front edge portion 13 of the irregular curved contour, clearly illustrated in FIG. 1 of the drawing. The narrow front edge of the device in the base portion 13' thereof is notched to form a platform 14, preferably of slightly curved contour, as noted in FIG. 2, the notch forming a perpendicular back or stop wall 15, as clearly seen in FIG. 3 of the drawing.

The upper narrow magnet supporting end 16 of the device is in the form of an inverted channel or, in other words, is defined by a top plate 17 and side plates 18, one of which is partially shown in section in FIG. 2 of the drawing. The front end of the channel is closed by an end wall 19, partially shown in section in FIG. 1 of the drawing, and it will appear that the edge 13 terminates in the lower edge of the side walls 18, as indicated in dotted lines at 13'' in FIG. 1 of the drawing. In the sectioning illustrated in the drawing, the device 10 is shown as formed of a molded plastic implement supporting device. The device, however, can be formed of any desired material or combinations of materials. Adhesively or otherwise fixed in the channel of the upper end 16, adjacent the end wall 19, is a disc-type magnet 20, having a down-

2

wardly extending magnetic flux through the open lower end of the channel construction, as will appear from a consideration of FIG. 2 of the drawing.

In illustrating one adaptation and use of my invention, I have diagrammatically shown one form of writing or marking implement such, for example, as a ball point pen 21, the ball point end 22 of which is adapted to rest on the platform 14, with the end 22 abutting the wall 15, which checks inward movement of the implement 21 in mounting the same on the device 10. The other end portion of the pen has suitably fixed in and exposed through said end a metallic cylinder 23 which, when brought into close proximity to the magnet 20, will be attracted by the flux of the magnet in maintaining the implement 21 in upright stabilized position in the holder, as diagrammatically seen in FIGS. 1 and 2 of the drawing. Considering these figures, it will be apparent that the implement 21 is widely spaced with respect to the curved edge 13 and the contraction of the sides 12, as seen at 12' in FIG. 2 of the drawing, renders the implement 21 freely accessible to be grasped by a hand in removing the implement for use and, in replacement of the implement in the holder, all that is essential is to bring the ball point or marking end in position on the platform 14 and then swing the same to a substantially vertical position; whereupon, the magnet 20 will take over in drawing the same into and maintaining it in the stabilized position, without any physical contact of the cylinder 23 with the magnet 20. This method of procedure avoids the necessity of bringing the marking implement into direct contact with the magnet and, further, leaves the implement very free for removal in the use thereof. The implement will maintain its upright position in the device or holder 10, even though the same may be subjected to slight vibratory actions or atmospheric breezes which may prevail in a room in which the device is supported upon a desk or other support.

The power of the magnet 20 is regulated with respect to the cylinder 23 employed and its spaced position with respect to the magnet. While the platform 14 is shown as transversely curved, this is simply for the purpose of localizing the ball point end of the writing implement. The surface 14 could be a flat surface, with simply a mark thereon to indicate the position upon which the writing end is to be placed in the operating of swinging the implement into the perpendicular position, where the magnet would take over in the magnetic flux action to maintain the same upright. The perpendicular wall 15, in like manner, is utilized to avoid the necessity of locating a spot or mark on a flat surface, so that the user simply moves the writing or marking end into contact with the surface 15 to locate the marking end perpendicularly beneath the magnet 20. It will be apparent that the cylinder 23 is composed of a material attractable to a magnet or the magnetic flux.

Having fully described my invention, what I claim as new and desire to secure by Letters Patent is:

1. A device of the character defined comprising a base having a platform on the upper surface thereof, the base having an upwardly extending portion having contracted side walls, said portion terminating in an upper magnet supporting end arranged above and in wide spaced relation to the base, said end including a portion in perpendicular alinement with part of said platform, a magnet supported in said last named portion, a writing implement

3

shorter in length than the distance between said magnet and platform, and said implement having means at one end attracted by the magnetic flux of said magnet for maintaining the implement supported on said part of the platform in perpendicular stabilized position by said magnetic flux.

2. A device as defined in claim 1, wherein said upper magnet supporting end is in the form of an inverted channel having a closed front end wall, and said magnet being positioned adjacent said end wall.

3. A device as defined in claim 1, wherein said up-

4

wardly contracted side walls have a forward narrow edge of rigidly curved contour to give free access to a writing implement supported in the device, and said platform including a perpendicular stop wall arranged in said forward edge controlling definite alinement of the implement with said magnet.

References Cited in the file of this patent

UNITED STATES PATENTS

2,693,788 Spatz ----- Nov. 9, 1954

5

10