

(19)



(11)

EP 3 217 468 A1

(12)

EUROPEAN PATENT APPLICATION
published in accordance with Art. 153(4) EPC

(43) Date of publication:
13.09.2017 Bulletin 2017/37

(51) Int Cl.:
H01P 1/201 (2006.01)

(21) Application number: **15867903.5**

(86) International application number:
PCT/CN2015/085087

(22) Date of filing: **24.07.2015**

(87) International publication number:
WO 2016/090925 (16.06.2016 Gazette 2016/24)

(84) Designated Contracting States:
AL AT BE BG CH CY CZ DE DK EE ES FI FR GB GR HR HU IE IS IT LI LT LU LV MC MK MT NL NO PL PT RO RS SE SI SK SM TR
Designated Extension States:
BA ME
Designated Validation States:
MA

(72) Inventors:
• **GU, Jian**
Shenzhen Guangdong 518129 (CN)
• **ZHANG, Hui**
Shenzhen Guangdong 518129 (CN)
• **DONG, Lifang**
Shenzhen Guangdong 518129 (CN)

(30) Priority: **08.12.2014 CN 201410743332**

(71) Applicant: **Huawei Technologies Co., Ltd.**
Longgang District
Shenzhen, Guangdong 518129 (CN)

(74) Representative: **Epping - Hermann - Fischer**
Patentanwaltsgesellschaft mbH
Schloßschmidstraße 5
80639 München (DE)

(54) **TRANSVERSE ELECTROMAGNETIC MODE DIELECTRIC FILTER, RADIO FREQUENCY MODULE AND BASE STATION**

(57) Embodiments of the present invention provide a transverse electromagnetic mode dielectric filter. A near-end rejection structure is disposed inside the filter. By flexibly designing a shape, a location, and a size of the near-end rejection structure, a transmission zero or zero cavity function is implemented, and a radio frequen-

cy signal on a high-frequency end or a low-frequency end out of a passband of the filter is rejected, thereby achieving good near-end rejection performance. The embodiments of the present invention further provide a radio frequency module and a base station.

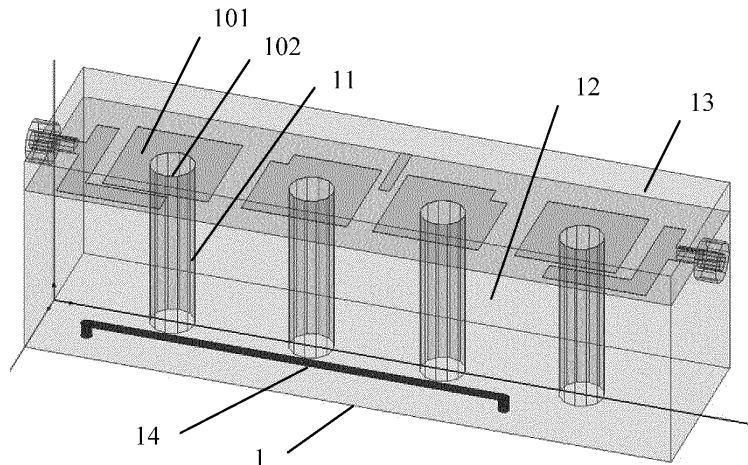

FIG. 1

EP 3 217 468 A1

Description

[0001] This application claims priority to Chinese Patent Application No. 201410743332.9, filed with the Chinese Patent Office on December 08, 2014 and entitled "TRANSVERSE ELECTROMAGNETIC MODE DIELECTRIC FILTER, RADIO FREQUENCY MODULE, AND BASE STATION", which is incorporated herein by reference in its entirety.

TECHNICAL FIELD

[0002] Embodiments of the present invention relate to the field of communications technologies, and in particular, to a transverse electromagnetic mode dielectric filter, a radio frequency module, and a base station.

BACKGROUND

[0003] With development of wireless communications technologies, a wireless communications device increasingly strives for miniaturization and a low insertion loss. Compared with a conventional metal cavity filter, a dielectric filter has an advantage such as a small size, a low insertion loss, high bearing power, and low costs. A transverse electromagnetic mode (TEM, transverse electromagnetic mode) dielectric filter is an important dielectric filter type, and may be applied to a device such as a wireless base station, a radio frequency terminal, or a radio frequency or microwave transceiver component.

[0004] However, a transverse electromagnetic mode dielectric filter provided in the prior art has poor near-end rejection performance, and therefore, cannot be applied to a location, such as a radio frequency front-end or a microwave antenna feeder front-end, that has a relatively high requirement on filter performance. Consequently, an application scenario is limited.

SUMMARY

[0005] Embodiments of the present invention provide a transverse electromagnetic mode dielectric filter that has good near-end rejection performance; and the embodiments of the present invention further provide a radio frequency module and a base station.

[0006] According to a first aspect, an embodiment of the present invention provides a transverse electromagnetic mode dielectric filter, including: a resonator, a dielectric body, and a metal housing, where an outer surface of the dielectric body is covered with a conductive material, the metal housing is fastened above the dielectric body, and there is a gap between the metal housing and the dielectric body; the resonator includes a resonant plate and a resonant hole, where the resonant plate is disposed on a top surface of the dielectric body, the resonant hole is a hollow cylindrical structure with openings on upper and lower ends, an upper opening of the resonant hole is provided on the resonant plate, a lower open-

ing of the resonant hole is provided on a lower surface of the dielectric body, an inner surface of the resonant hole is covered with a conductive material, and the resonant plate is of a metal materials; and the filter further includes a near-end rejection structure, where the near-end rejection structure is inside the dielectric body, and a shape, a location, and a size of the near-end rejection structure are determined by a frequency of a signal that the filter is to filter out.

[0007] In a first possible implementation of the first aspect, that a shape, a location, and a size of the near-end rejection structure are determined by a frequency of a signal that the filter is to filter out includes:

a height, a length, and a distance away from the resonant hole that are of the near-end rejection structure are determined according to a coupling coefficient of the filter, where the coupling coefficient is corresponding to the frequency of the signal that the filter is to filter out.

[0008] With reference to either of the possible implementations, in a second possible implementation of the first aspect, the near-end rejection structure has at least two ends in contact with the lower surface of the dielectric body, and a remaining part of the near-end rejection structure is within a magnetic field area inside the dielectric body.

[0009] With reference to any one of the possible implementations, in a third possible implementation of the first aspect, the near-end rejection structure is within an electric field area inside the dielectric body.

[0010] With reference to any one of the possible implementations, in a fourth possible implementation of the first aspect, that a shape, a location, and a size of the near-end rejection structure are determined by a frequency of a signal that the filter is to filter out includes: a height, a length, and a distance away from the resonant hole that are of the near-end rejection structure are determined according to an electrical wavelength corresponding to the frequency of the signal that the filter is to filter out.

[0011] With reference to any one of the possible implementations, in a fifth possible implementation of the first aspect, the near-end rejection structure is any one of a metalized through hole, a metalized strip line, a physical metal structure, a metalized conductor, or a thin metal piece.

[0012] According to a second aspect, an embodiment of the present invention provides a radio frequency module, including the transverse electromagnetic mode dielectric filter according to any one of the first aspect or the possible implementations.

[0013] According to a third aspect, an embodiment of the present invention provides a base station, including the radio frequency module according to the second aspect.

[0014] According to technical solutions provided in the

embodiments of the present invention, a near-end rejection structure is disposed inside a transverse electromagnetic mode dielectric filter. By flexibly designing a shape, a location, and a size of the near-end rejection structure, a transmission zero or zero cavity function is implemented, and a radio frequency signal on a high-frequency end or a low-frequency end out of a passband of the filter is rejected. The transverse electromagnetic mode dielectric filter provided in the embodiments of the present invention has good near-end rejection performance, and may be widely applied to a radio frequency module and a base station.

BRIEF DESCRIPTION OF DRAWINGS

[0015] To describe the technical solutions in the embodiments of the present invention more clearly, the following briefly describes the accompanying drawings required for describing the embodiments. Apparently, the accompanying drawings in the following description show merely some embodiments of the present invention, and persons of ordinary skill in the art may still derive other drawings from these accompanying drawings without creative efforts.

FIG. 1 is a schematic structural diagram of a transverse electromagnetic mode dielectric filter according to an embodiment of the present invention;
 FIG. 2 is a front view of another transverse electromagnetic mode dielectric filter according to an embodiment of the present invention;
 FIG. 3 is a top view of another transverse electromagnetic mode dielectric filter according to an embodiment of the present invention;
 FIG. 4 is a schematic structural diagram of another transverse electromagnetic mode dielectric filter according to an embodiment of the present invention;
 and
 FIG. 5 is a schematic structural diagram of a base station according to an embodiment of the present invention.

DESCRIPTION OF EMBODIMENTS

[0016] To make the objectives, technical solutions, and advantages of the present invention clearer, the following further describes implementations of the present invention in detail with reference to the accompanying drawings.

[0017] A filter is a necessary component in a device such as a base station or a radio frequency terminal. With an advantage in costs, size, and the like, a dielectric filter may be applied at a location such as a receive link of the base station, and is configured to perform filtering on a radio frequency signal. A transverse electromagnetic mode dielectric filter is a widely-used dielectric filter.

[0018] However, a radio frequency performance indicator of the transverse electromagnetic mode dielectric

filter is relatively poor, and cannot be used at a location, such as a front-end of a radio frequency module, that is, a location between a transmit antenna and a power amplifier, that has a relatively high requirement on the performance of the filter. The radio frequency performance indicator of the filter includes multiple indicators such as an insertion loss, rejection, and inter-modulation. Therefore, an application scenario of the transverse electromagnetic mode dielectric filter is greatly limited.

[0019] A main reason causing the relatively poor radio frequency performance indicator of the transverse electromagnetic mode dielectric filter is that near-end rejection performance of this type of filter is poor. Near-end rejection is also referred to as sideband rejection or near band rejection (near band rejection), and means performing strong rejection on a signal on a high-frequency end or a low-frequency end near an outside area of a passband of the filter, so as to ensure a filtering effect. Currently, a design method for cross-coupling or resonance of the transverse electromagnetic mode dielectric filter is inflexible, a transmission zero or zero cavity structure cannot be formed effectively, and therefore, the filter does not have good near-end rejection performance.

[0020] FIG. 1 is a schematic diagram of a transverse electromagnetic mode dielectric filter according to an embodiment of the present invention.

[0021] As shown in FIG. 1, a transverse electromagnetic mode dielectric filter 1 ("filter 1" for short below) includes a resonator 11, a dielectric body 12, and a metal housing 13. The metal housing 13 is fastened above the dielectric body 12, and there is a gap between the metal housing 13 and the dielectric body 12.

[0022] An outer surface of the dielectric body 12 is covered with a conductive material. Optionally, a metal coating, such as a silver coating, may be used.

[0023] The gap between the metal housing 13 and the dielectric body 12 is filled with air.

[0024] The resonator 11 includes a resonant plate 101 and a resonant hole 102, and the resonant plate 101 is disposed on a top surface of the dielectric body 12.

[0025] Optionally, the resonant plate 101 may be a thin metal piece disposed on the top surface of the dielectric body 12, or may be a metal coating printed on the top surface of the dielectric body 12.

[0026] Optionally, a shape of the resonant plate 101 is not limited. For example, the shape may be a regular figure such as a rectangle or a circle, or may be modified on the basis of the regular figure according to specifications and a performance requirement of the filter, for example, a specific area is cut off to form an irregular figure. This is not particularly limited in this embodiment of the present invention.

[0027] The resonant hole 102 is a hollow cylindrical structure with openings on upper and lower ends, an upper opening of the resonant hole 102 is provided on the resonant plate 101, a lower opening of the resonant hole 102 is provided on a lower surface of the dielectric body 12, and an inner surface of the resonant hole 102 is cov-

ered with a conductive material.

[0028] Optionally, the conductive material covering the inner surface of the resonant hole 102 may be a metal coating, such as a silver coating.

[0029] Optionally, the resonant hole 102 and the resonant plate 101 may be integrally formed, or may be separately made and then formed by means of connection.

[0030] The filter 1 further includes a near-end rejection structure 14. The near-end rejection structure 14 is inside the dielectric body 12, and a shape, a location, and a size of the near-end rejection structure 14 are determined by a frequency of a signal that the filter is to filter out.

[0031] As shown in FIG. 1, two ends of the near-end rejection structure 14 are in contact with the lower surface of the dielectric body 12, and a remaining part of the near-end rejection structure 14 is within a magnetic field area inside the dielectric body 12. The magnetic field area refers to an area that is inside the dielectric body and that has a stronger magnetic field than that of another location.

[0032] A strong magnetic field area inside the dielectric body 12 is an area near the lower surface of the dielectric body 12.

[0033] Optionally, a height, a length, and a distance away from the resonant hole that are of the near-end rejection structure 14 may be determined according to a coupling coefficient (coupling coefficient) of the filter, and the coupling coefficient is corresponding to the frequency of the signal that the filter is to filter out.

[0034] The coupling coefficient is an important parameter during filter design. When the coupling coefficient is determined, a physical structure of the filter may be designed according to the coupling coefficient, and a corresponding performance indicator may be achieved. Generally, the coupling coefficient may be obtained by solving a coupling matrix (coupling matrix). The coupling matrix may be used to indicate a coupling energy relationship between resonant cavities, and the coupling coefficient is included in the coupling matrix.

[0035] Optionally, the coupling matrix may be obtained by means of calculation by using filter emulation software, or may be determined according to an experimental or empirical value. This is not particularly limited in this embodiment of the present invention.

[0036] Optionally, the near-end rejection structure 14 may be any one of a metalized through hole, a metalized strip line, a physical metal structure, a metalized conductor, or a thin metal piece.

[0037] Optionally, the near-end rejection structure 14 may be a strip structure with a specific radian. Specifically, the radian may be determined by means of debugging according to the performance requirement of the filter. This is not particularly limited in this embodiment of the present invention.

[0038] Optionally, in another embodiment of the present invention, in addition to the two ends, any other part of the near-end rejection structure 14 may also be in contact with the lower surface of the dielectric body

12, to play a grounding role.

[0039] In the embodiment shown in FIG. 1, the near-end rejection structure 14 plays an inductive transmission zero role, and can improve a rejection capability on a high-frequency end out of a passband of the filter, that is, can reject a signal on the high-frequency end out of the passband of the filter. It may be understood that the near-end rejection structure 14 may be designed for only one specific signal frequency, and when the filter has strong rejection over a specific frequency, the filter has good rejection over a frequency band neighboring to the frequency.

[0040] Optionally, the filter 1 may include more than three resonators 11, and the near-end rejection structure 14 is located between nonadjacent resonant cavities. As shown in FIG. 1, the filter 1 includes four resonators, successively marked as cavity 1, cavity 2, cavity 3, and cavity 4 from left to right. The two ends of the near-end rejection structure 14 are respectively located near the cavity 1 and cavity 3. Optionally, the near-end rejection structure 14 may be located between the cavity 1 and cavity 4, or between the cavity 2 and cavity 4.

[0041] The near-end rejection structure 14 located between nonadjacent resonant cavities forms a cross-coupling structure, that is, when signals pass through resonant cavities through different signal paths, phases of different signal paths are canceled, so as to form a transmission zero. For example, a signal path of cavity 1-cavity 2-cavity 3 may be considered as a positive phase path, and a signal path of cavity 1-cavity 3 is considered as a negative phase path. Phases of the two paths are canceled, and a transmission zero is formed at the near-end rejection structure 14. The zero is corresponding to the frequency of the signal that the filter is to filter out.

[0042] According to the transverse electromagnetic mode dielectric filter provided in this embodiment of the present invention, a near-end rejection structure is disposed inside the dielectric filter and near a lower surface of the dielectric filter, so as to implement an inductive transmission zero function, and reject a radio frequency signal on a high-frequency end out of a passband of the filter, thereby achieving good near-end rejection performance.

[0043] FIG. 2 and FIG. 3 are a front view and a top view of another transverse electromagnetic mode dielectric filter according to an embodiment of the present invention.

[0044] As shown in FIG. 2, a transverse electromagnetic mode dielectric filter 2 ("filter 2" for short below) includes a resonator 21, a dielectric body 22, a metal housing 23, and a near-end rejection structure 24. The metal housing 23 is fastened above the dielectric body 22, and there is a gap between the metal housing 23 and the dielectric body 22. As shown in FIG. 3, the resonator 21 includes a resonant plate 211 and a resonant hole 212.

[0045] Overall structures of the filter 2 and the filter 1 provided in the embodiment shown in FIG. 1 are similar, and what is different from the embodiment shown in FIG.

1 is that the near-end rejection structure 24 is located at an area near a top surface of the dielectric body 22. The area is an electric field area inside the dielectric body 22, and the electric field area refers to an area that is inside the dielectric body and that has a stronger electric field than that of another location. A specific shape, location, and size of the near-end rejection structure 24 may be determined according to a coupling coefficient of the filter. For a specific determining manner, reference may be made to the description in the embodiment shown in FIG. 1. This is not described herein.

[0046] In the embodiments shown in FIG. 2 and FIG. 3, the near-end rejection structure 24 plays a capacitive transmission zero role, and can improve a rejection capability on a low-frequency end out of a passband of the filter, that is, can reject a signal on the low-frequency end out of the passband of the filter.

[0047] It may be understood that for detailed description of another component in the filter 2, reference may be made to the content in the embodiment shown in FIG. 1. This is not described herein.

[0048] A transverse electromagnetic mode dielectric filter whose specification is $90^{\circ}44^{\circ}20$ (mm, millimeter) is used as an example. A near-end rejection structure is disposed inside a dielectric body of the filter to serve as a capacitive zero. The structure is a metalized through hole whose specific size is as follows: A length is 23 mm, a width is 1 mm, a distance away from a resonant hole is 3 mm, and a distance away from a top surface of the dielectric body, that is, a resonant plate, is 3 mm. A passband of the filter is 1805 MHz to 1865 MHz, that is, a radio frequency signal whose frequency is beyond this frequency band can be effectively filtered out.

[0049] According to the transverse electromagnetic mode dielectric filter provided in this embodiment of the present invention, a near-end rejection structure is disposed inside the dielectric filter and near a top surface of a dielectric body, so as to implement a capacitive transmission zero function, and reject a radio frequency signal on a low-frequency end out of a passband of the filter, thereby achieving good near-end rejection performance.

[0050] FIG. 4 is a schematic diagram of another transverse electromagnetic mode dielectric filter according to an embodiment of the present invention.

[0051] As shown in FIG. 4, a transverse electromagnetic mode dielectric filter 3 ("filter 3" for short below) includes a resonator 31, a dielectric body 32, a metal housing 33, and a near-end rejection structure 34. The metal housing 33 is fastened above the dielectric body 32, there is a gap between the metal housing 33 and the dielectric body 32, and the resonator 31 includes a resonant plate 301 and a resonant hole 302.

[0052] Overall structures of the filter 3 and the transverse electromagnetic mode dielectric filter provided in the embodiment in FIG. 1 or FIG. 2 and FIG. 3 are similar, and what is different from the filter shown in FIG. 1 or FIG. 2 is that a shape, a location, and a size of the near-end rejection structure 34 are determined by an electrical

wavelength corresponding to a frequency of a signal that the filter is to filter out. The electrical wavelength is an electromagnetic wave wavelength.

[0053] Specifically, the electrical wavelength may be calculated according to a formula: $c=\lambda \cdot f$, where f is a signal frequency, λ is an electrical wavelength, and c is a constant.

[0054] It can be learned that a wavelength and a frequency of an electromagnetic wave waveform are in a one-to-one correspondence relationship. A height, a length, and a distance away from the resonant hole 302 that are of the near-end rejection structure 34 may be determined according to the electrical wavelength. Specifically, a size of the near-end rejection structure 34 may be determined by using filter emulation software, or may be determined according to an experiment or experience. This is not particularly limited in this embodiment of the present invention.

[0055] Optionally, as shown in FIG. 4, the near-end rejection structure 34 may be a strip structure with a bending angle, or may be a strip or tube structure with a radian in another embodiment.

[0056] As shown in FIG. 4, two ends of the near-end rejection structure 34 are contacted to a lower surface of the dielectric body 32. Optionally, in another embodiment, in addition to the two ends, any other parts of the near-end rejection structure 34 may also be contacted to the lower surface of the dielectric body 32.

[0057] In the embodiment shown in FIG. 4, the near-end rejection structure 34 may play a zero cavity role, and may improve a rejection capability on a high-frequency end or a low-frequency end out of a passband of the filter, that is, may reject a signal on the high-frequency end or the low-frequency end out of the passband of the filter.

[0058] Optionally, by changing a structure of the near-end rejection structure 34, such as changing a length, the electrical wavelength corresponding to the near-end rejection structure 34 may be changed, so as to control the frequency of the signal that the filter is to filter out. Specifically, the length of the near-end rejection structure 34 is inversely proportional to the signal frequency. A longer near-end rejection structure 34 indicates a lower corresponding signal frequency, and the filter 3 may be configured to filter out a signal on a low-frequency end. A shorter near-end rejection structure 34 indicates a higher corresponding signal frequency, and the filter 3 may be configured to filter out a signal on a high-frequency end.

[0059] It may be understood that for detailed description of another component in the filter 3, reference may be made to the content in the embodiment shown in FIG. 1 or FIG. 2 and FIG. 3. This is not described herein.

[0060] This embodiment of the present invention further provides a radio frequency module. The radio frequency module includes any transverse electromagnetic mode dielectric filter described in the foregoing embodiments.

[0061] Optionally, the radio frequency module may be a repeater, a remote radio unit (RRU, remote radio unit), a radio frequency unit (RFU, radio frequency unit), or another device. This is not particularly limited in this embodiment of the present invention.

[0062] According to the transverse electromagnetic mode dielectric filter or the radio frequency module provided in this embodiment of the present invention, when a size of the filter is not increased, a zero cavity function can be implemented by disposing a near-end rejection structure inside a dielectric body; and by using the structure, a signal on a high-frequency end or a low-frequency end out of a passband of the filter can be rejected, and near-end rejection performance of the filter can be improved, thereby improving a filtering effect.

[0063] FIG. 5 is an example diagram of a base station according to an embodiment of the present invention. The base station may include a radio frequency module, and the radio frequency module includes the transverse electromagnetic mode dielectric filter shown in any embodiment in FIG. 1 to FIG. 4.

[0064] The base station may further include a base-band processing unit (BBU, base band unit) 402, a power module 403, and the like. All modules or units may be connected by using a communications bus.

[0065] Optionally, the base station may be a small cell (small cell) device, such as an indoor small cell product.

[0066] The radio frequency module or the base station provided in this embodiment of the present invention uses a transverse electromagnetic mode dielectric filter with good near-end rejection performance, and therefore has low costs and a small size.

[0067] An embodiment of the present invention further provides a method for producing any transverse electromagnetic mode dielectric filter ("filter" for short below) according to FIG. 1 to FIG. 4.

[0068] The method includes: preparing two layers or multiple layers of dielectric blank raw materials; after a through hole or a blind hole is provided on the two layers or multiple layers of dielectric raw materials, separately sintering each layer of dielectric raw material; preparing a metalized structure and a punching on each layer of sintered dielectric; then forming a filter entirety by means of bonding; and forming the transverse electromagnetic mode dielectric filter provided in this embodiment of the present invention after metallization of a printed pattern of the filter is completed.

[0069] In another embodiment of the present invention, the method may be: preparing two layers or multiple layers of dielectric blank raw materials; obtaining a required metal structure, that is, a transmission zero or zero cavity structure in the present invention, by means of opening a hole, printing a circuit, and the like on each layer of dielectric raw material; then stacking prepared layers of dielectric raw materials together for sintering; and finally forming the transverse electromagnetic mode dielectric filter provided in this embodiment of the present invention after metallization of a printed pattern of the dielectric

filter is completed.

[0070] Finally, it should be noted that the foregoing embodiments are merely intended for describing the technical solutions of the present invention, but not for limiting the present invention. Although the present invention is described in detail with reference to the foregoing embodiments, persons of ordinary skill in the art should understand that they may still make modifications to the technical solutions described in the foregoing embodiments or make equivalent replacements to some or all technical features thereof, without departing from the scope of the technical solutions of the embodiments of the present invention.

Claims

1. A transverse electromagnetic mode dielectric filter, comprising:

a resonator, a dielectric body, and a metal housing, wherein an outer surface of the dielectric body is covered with a conductive material, the metal housing is fastened above the dielectric body, and there is a gap between the metal housing and the dielectric body;

the resonator comprises a resonant plate and a resonant hole, wherein the resonant plate is disposed on a top surface of the dielectric body, the resonant hole is a hollow cylindrical structure with openings on upper and lower ends, an upper opening of the resonant hole is provided on the resonant plate, a lower opening of the resonant hole is provided on a lower surface of the dielectric body, an inner surface of the resonant hole is covered with a conductive material, and the resonant plate is of a metal material; and the filter further comprises a near-end rejection structure, wherein the near-end rejection structure is inside the dielectric body, and a shape, a location, and a size of the near-end rejection structure are determined by a frequency of a signal that the filter is to filter out.

2. The filter according to claim 1, wherein that a shape, a location, and a size of the near-end rejection structure are determined by a frequency of a signal that the filter is to filter out comprises:

a height, a length, and a distance away from the resonant hole that are of the near-end rejection structure are determined according to a coupling coefficient of the filter, wherein the coupling coefficient is corresponding to the frequency of the signal that the filter is to filter out.

3. The filter according to claim 2, wherein the near-end rejection structure has at least two ends in contact

with the lower surface of the dielectric body, and a remaining part of the near-end rejection structure is within a magnetic field area inside the dielectric body.

4. The filter according to claim 2, wherein the near-end rejection structure is within an electric field area inside the dielectric body. 5
5. The filter according to claim 1, wherein that a shape, a location, and a size of the near-end rejection structure are determined by a frequency of a signal that the filter is to filter out comprises: 10
- a height, a length, and a distance away from the resonant hole that are of the near-end rejection structure are determined according to an electrical wavelength corresponding to the frequency of the signal that the filter is to filter out. 15
6. The filter according to any one of claims 1 to 5, wherein the near-end rejection structure is any one of a metalized through hole, a metalized strip line, a physical metal structure, a metalized conductor, or a thin metal piece. 20
- 25
7. A radio frequency module, comprising the transverse electromagnetic mode dielectric filter according to any one of claims 1 to 6.
8. Abase station, comprising the radio frequency module according to claim 7. 30

35

40

45

50

55

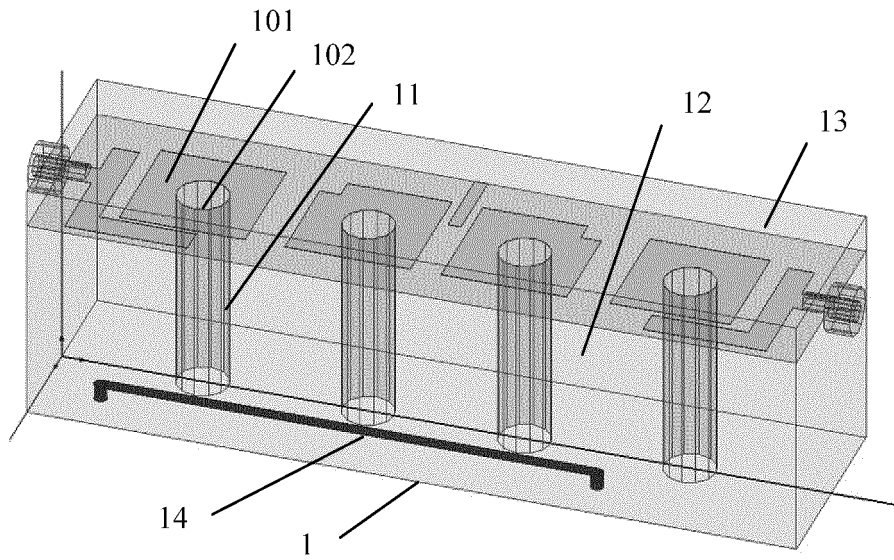

FIG. 1

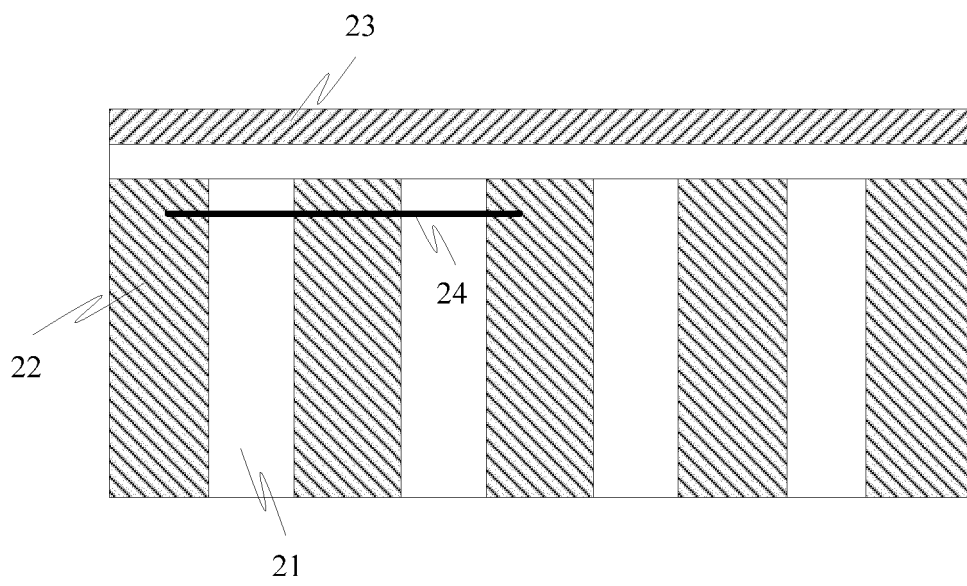

FIG. 2

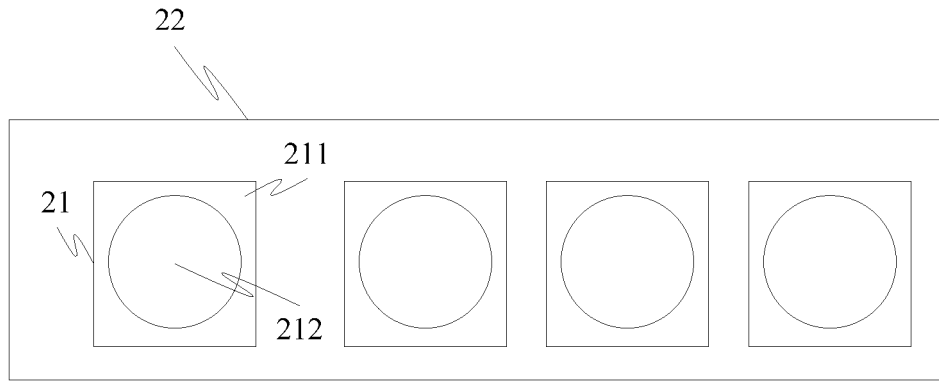

FIG. 3

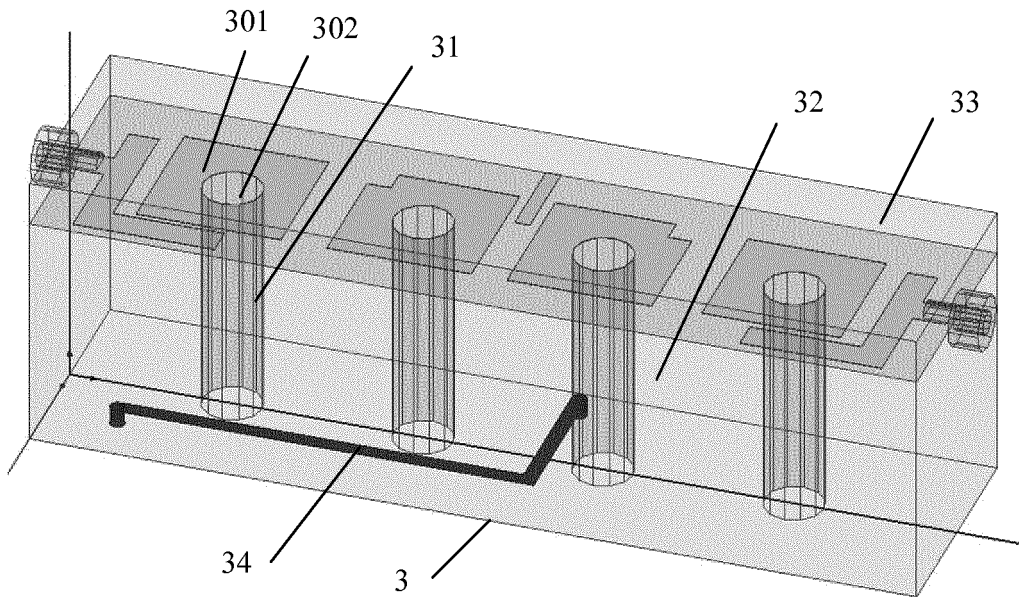

FIG. 4

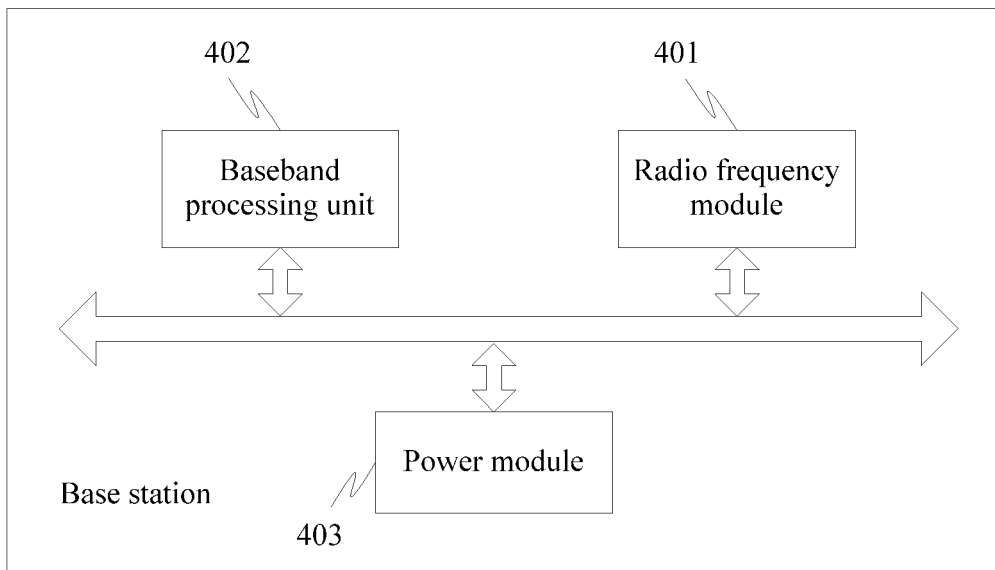

FIG. 5

INTERNATIONAL SEARCH REPORT

International application No.

PCT/CN2015/085087

A. CLASSIFICATION OF SUBJECT MATTER		
H01P 1/201 (2006.01) i		
According to International Patent Classification (IPC) or to both national classification and IPC		
B. FIELDS SEARCHED		
Minimum documentation searched (classification system followed by classification symbols)		
H04W; H04N; H01P		
Documentation searched other than minimum documentation to the extent that such documents are included in the fields searched		
Electronic data base consulted during the international search (name of data base and, where practicable, search terms used) CNTXT; CNKI; CNABS; VEN: transverse electromagnetic mode, transverse electric mode, transverse magnetic mode, transverse, electromagnetic, mode, electric, magnetic, filter, restrain, transmission zero, resonance, hole, plate		
C. DOCUMENTS CONSIDERED TO BE RELEVANT		
Category*	Citation of document, with indication, where appropriate, of the relevant passages	Relevant to claim No.
A	CN 202855879 U (WUHAN FINGU ELECTRONIC TECHNOLOGY CO., LTD.), 03 April 2013 (03.04.2013), the whole document	1-8
A	CN 103928731 A (HUAWEI TECHNOLOGIES CO., LTD.), 16 July 2014 (16.07.2014), the whole document	1-8
A	CN 102760923 A (CHINA GRENTech CORPORATION LIMITED), 31 October 2012 (31.10.2012), the whole document	1-8
A	US 2003201849 A1 (UCHIYAMA et al.), 30 October 2003 (30.10.2003), the whole document	1-8
PX	CN 104466315 A (SHANGHAI HUAWEI TECHNOLOGIES CO., LTD.), 25 March 2015 (25.03.2015)	1-8
<input type="checkbox"/> Further documents are listed in the continuation of Box C. <input checked="" type="checkbox"/> See patent family annex.		
* Special categories of cited documents: "A" document defining the general state of the art which is not considered to be of particular relevance "E" earlier application or patent but published on or after the international filing date "L" document which may throw doubts on priority claim(s) or which is cited to establish the publication date of another citation or other special reason (as specified) "O" document referring to an oral disclosure, use, exhibition or other means "P" document published prior to the international filing date but later than the priority date claimed	"T" later document published after the international filing date or priority date and not in conflict with the application but cited to understand the principle or theory underlying the invention "X" document of particular relevance; the claimed invention cannot be considered novel or cannot be considered to involve an inventive step when the document is taken alone "Y" document of particular relevance; the claimed invention cannot be considered to involve an inventive step when the document is combined with one or more other such documents, such combination being obvious to a person skilled in the art "&" document member of the same patent family	
Date of the actual completion of the international search 19 October 2015 (19.10.2015)		Date of mailing of the international search report 29 October 2015 (29.10.2015)
Name and mailing address of the ISA/CN: State Intellectual Property Office of the P. R. China No. 6, Xitucheng Road, Jimenqiao Haidian District, Beijing 100088, China Facsimile No.: (86-10) 62019451		Authorized officer QI, Jingwei Telephone No.: (86-10) 62411482

Form PCT/ISA/210 (second sheet) (July 2009)

INTERNATIONAL SEARCH REPORT
Information on patent family members

International application No.
PCT/CN2015/085087

5
10
15
20
25
30
35
40
45
50
55

Patent Documents referred in the Report	Publication Date	Patent Family	Publication Date
CN 202855879 U	03 April 2013	None	
CN 103928731 A	16 July 2014	None	
CN 102760923 A	31 October 2012	CN 102760923 B	29 April 2015
US 2003201849 A1	30 October 2003	CN 1284263 C	08 November 2006
		JP 2003318607 A	07 November 2003
		JP 3883902 B2	21 February 2007
		US 6677836 B2	13 January 2004
		CN 1453898 A	05 November 2003
CN 104466315 A	25 March 2015	None	

Form PCT/ISA/210 (patent family annex) (July 2009)

REFERENCES CITED IN THE DESCRIPTION

This list of references cited by the applicant is for the reader's convenience only. It does not form part of the European patent document. Even though great care has been taken in compiling the references, errors or omissions cannot be excluded and the EPO disclaims all liability in this regard.

Patent documents cited in the description

- CN 201410743332 [0001]