



US00D366014S

United States Patent [19]

[11] Patent Number: **Des. 366,014**

Lindquist et al.

[45] Date of Patent: ****Jan. 9, 1996**

[54] **SNOWMOBILE SKI**

[76] Inventors: **David T. Lindquist**, 19 E. 1110 South, Kaysville, Utah 84037; **Ryan B. Packard**, 1418 Maple Hills Dr., Bountiful, Utah 84010

[**] Term: **14 Years**

[21] Appl. No.: **38,879**

[22] Filed: **May 12, 1995**

[52] U.S. Cl. **D12/7**

[58] Field of Search D12/7; 280/12.1, 280/13, 22, 28, 607; 180/180-184, 190

4,105,217	8/1978	Metelow et al.	280/28
4,108,453	8/1978	Lavalier	280/28
4,180,275	12/1979	Montoya	280/28
4,194,753	3/1980	Schushuhn, Jr.	280/13
4,221,394	9/1980	Campbell	280/12.1
4,305,603	12/1981	Miller et al.	280/607
4,413,832	11/1983	Pendleton	280/12.1
4,491,333	1/1985	Wamke	280/28
4,595,211	6/1986	Fitzpatrick	280/28
4,778,190	10/1988	Meredith	280/13
5,141,243	8/1992	Meatto	280/602
5,145,201	9/1992	Metheny	280/609
5,165,709	11/1992	Jacques	280/28
5,344,168	9/1994	Olson et al.	280/28

[56] References Cited

U.S. PATENT DOCUMENTS

D. 255,893	7/1980	Fritz	D12/7
D. 256,224	8/1980	Fritz	280/28
3,321,211	5/1967	Bryant et al.	280/13
3,643,979	2/1972	Richards	280/28
3,675,939	7/1972	Vik	280/28
3,732,939	5/1973	Samson	280/28
3,774,926	11/1973	Chase	280/13
3,778,074	12/1973	Kozlow	280/28
3,844,367	10/1974	Flohr	280/28
3,850,440	11/1974	Reedy et al.	280/28
3,866,933	2/1975	Mollring	280/28
3,871,675	3/1975	Lund	280/28
3,897,839	8/1975	Brisebois	180/190
3,942,812	3/1976	Kozlow	280/28
4,077,639	3/1978	Reedy	280/28

Primary Examiner—A. Hugo Word
 Assistant Examiner—M. Brown
 Attorney, Agent, or Firm—Workman, Nydegger & Seeley

[57] CLAIM

The ornamental design for a snowmobile ski, as shown and described.

DESCRIPTION

FIG. 1 is a perspective view of a snowmobile ski showing our design;
 FIG. 2 is a top plan view thereof;
 FIG. 3 is a side elevational view thereof;
 FIG. 4 is a bottom plan view thereof;
 FIG. 5 is a front end elevational view thereof; and,
 FIG. 6 is a rear end elevational view thereof.

1 Claim, 3 Drawing Sheets

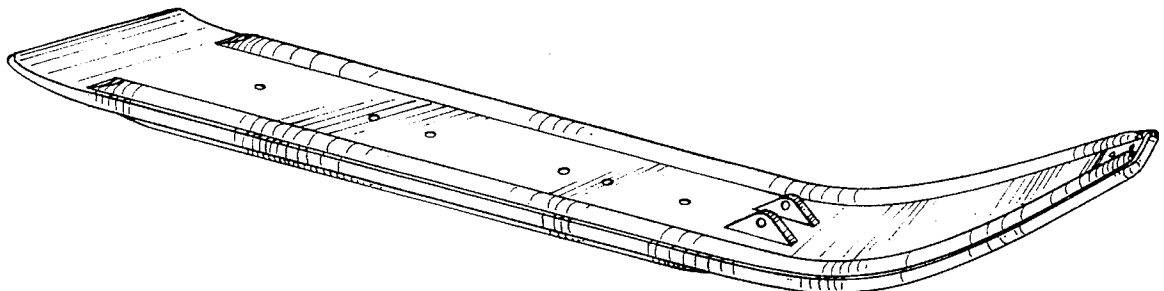

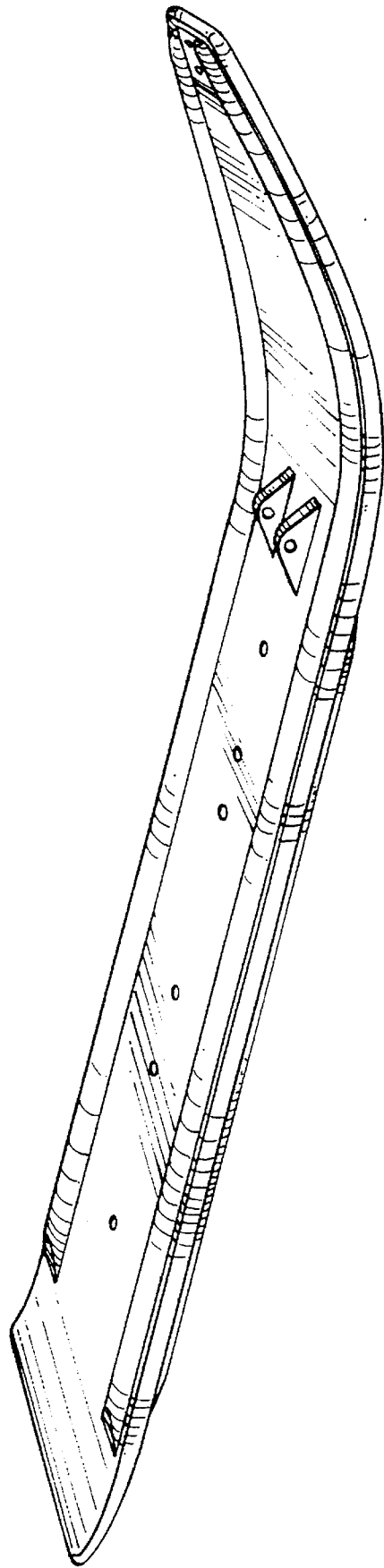

FIG. 1

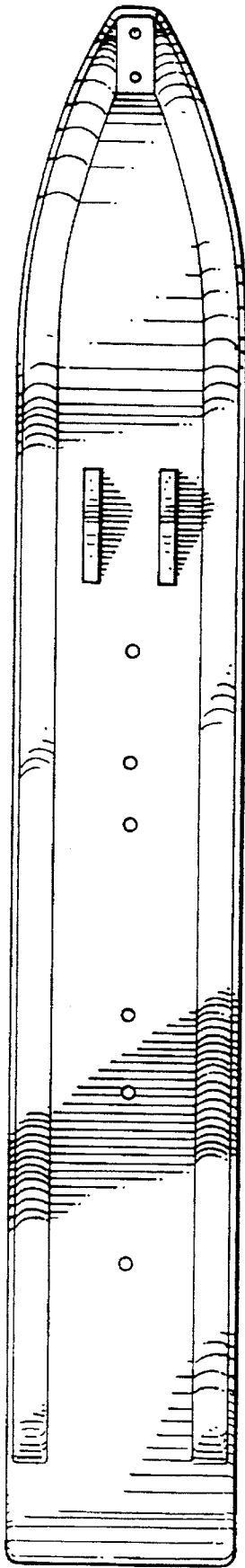

FIG. 2

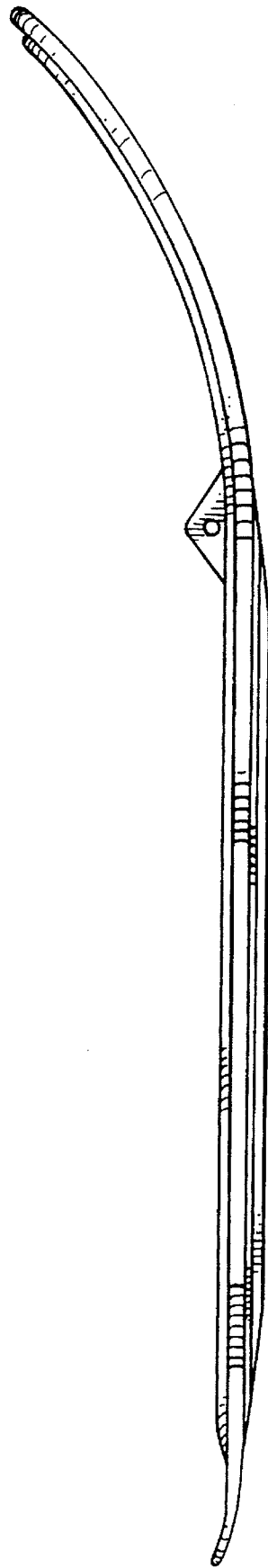

FIG. 3

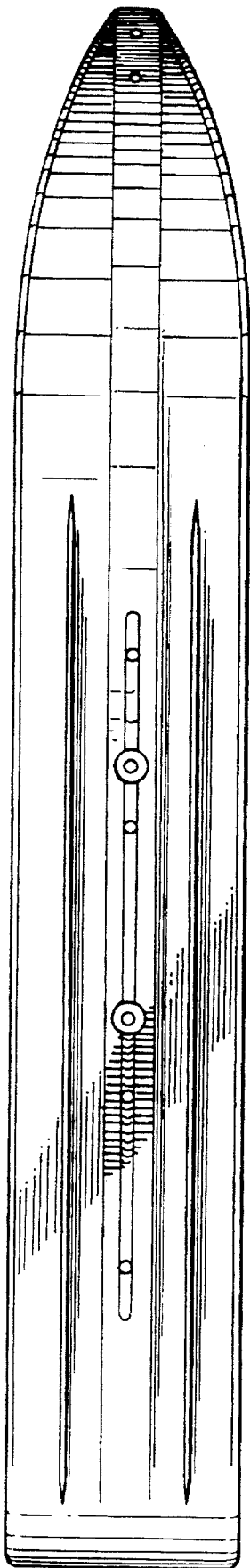

FIG. 4

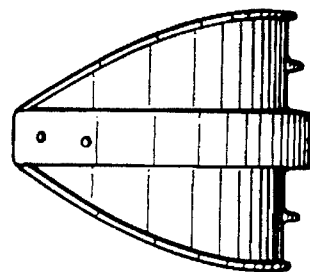

FIG. 5

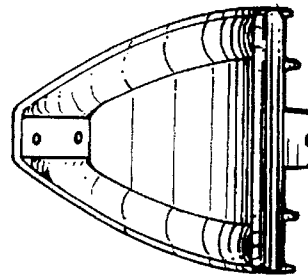

FIG. 6