



US 20050252772A1

(19) **United States**

(12) **Patent Application Publication**

Paul et al.

(10) **Pub. No.: US 2005/0252772 A1**

(43) **Pub. Date: Nov. 17, 2005**

(54) **FLOW DEVICE**

(63) Continuation-in-part of application No. 10/198,223, filed on Jul. 17, 2002.

(76) Inventors: **Philip H. Paul**, Livermore, CA (US);
David W. Neyer, Castro Valley, CA (US);
Jason E. Rehm, Alameda, CA (US)

Publication Classification

(51) **Int. Cl.⁷** **G01N 27/27**
(52) **U.S. Cl.** **204/450; 204/600**

Correspondence Address:
SHELDON & MAK, INC
225 SOUTH LAKE AVENUE
9TH FLOOR
PASADENA, CA 91101 (US)

(57) **ABSTRACT**

Liquid flow devices, particularly microfluidic devices, containing solid porous materials. Flow in the devices can be pressure-driven flow and/or electroosmotic flow. The porous materials are preferably pre-shaped, for example divided from a sheet of porous material, so that they can be assembled with liquid-impermeable barrier materials around them. The devices can for example be prepared by lamination. A wide variety of devices, including mixing devices, is disclosed. A mixing device is illustrated in FIG. 23.

(21) Appl. No.: **10/521,093**

(22) PCT Filed: **Jul. 16, 2003**

(86) PCT No.: **PCT/US03/22306**

Related U.S. Application Data

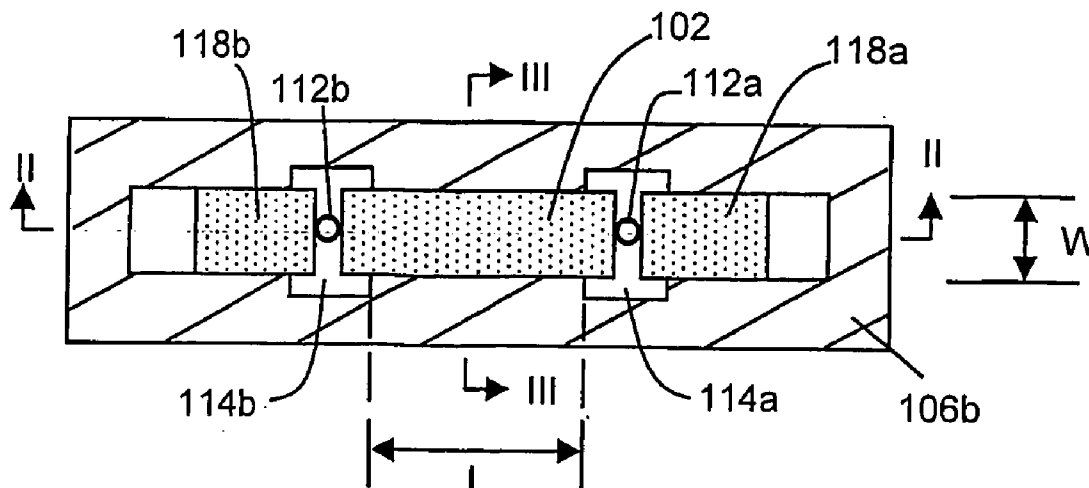

FIG. 1

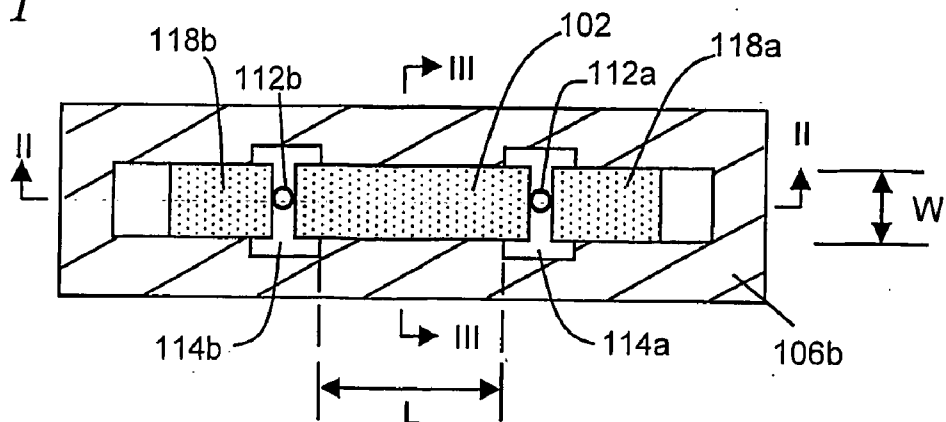

FIG. 2

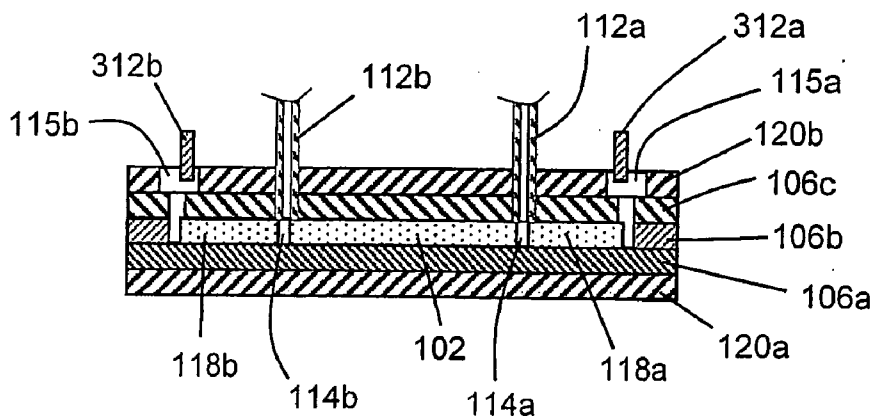

FIG. 3

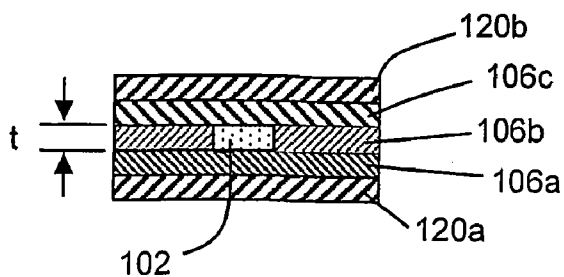

FIG. 4

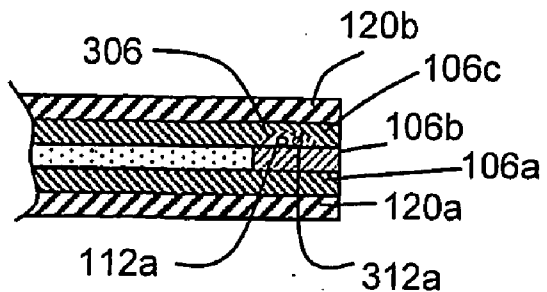

FIG. 5

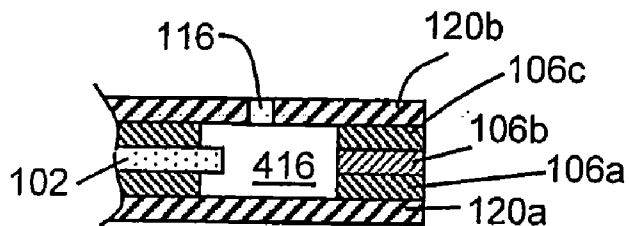

FIG. 6

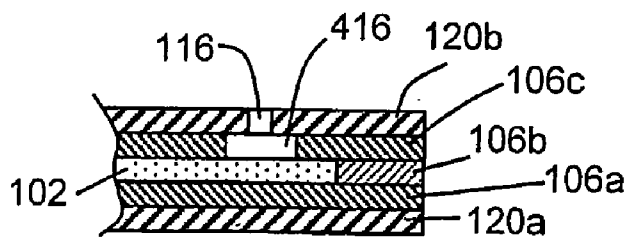

FIG. 7

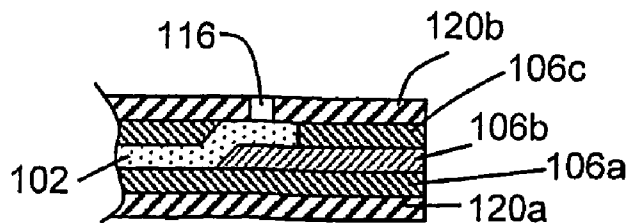

FIG. 8

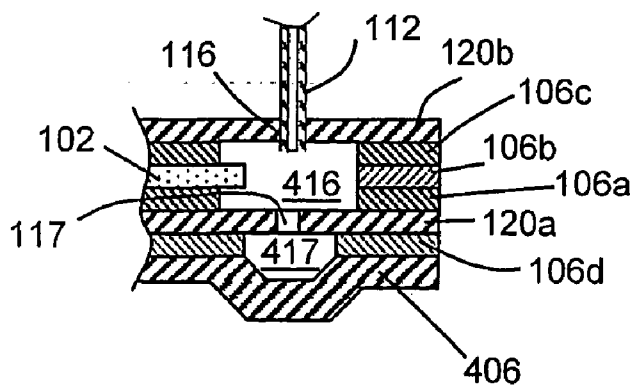

FIG. 9

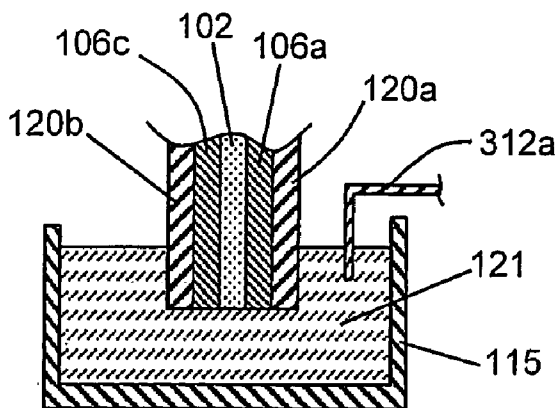

FIG. 10

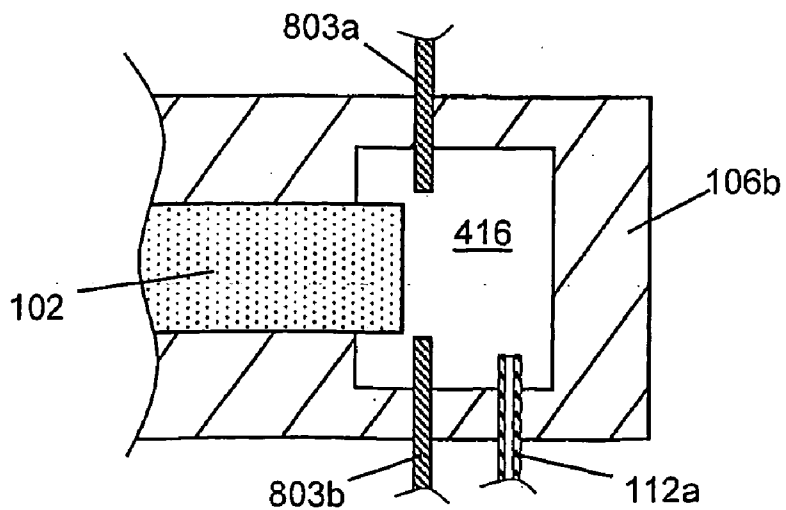

FIG. 11

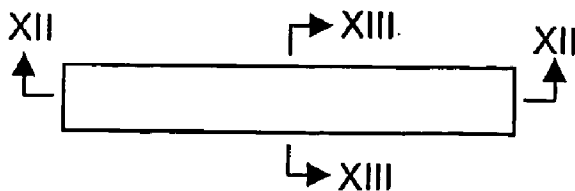

FIG. 12



FIG. 13



FIG. 14

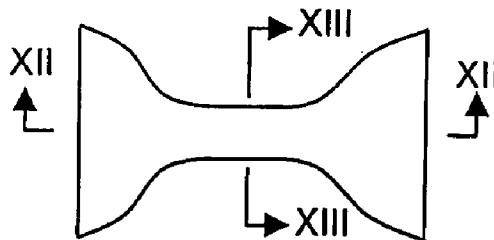

FIG. 15

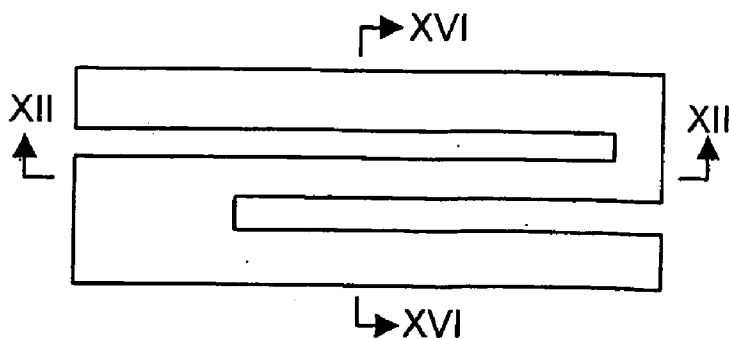

FIG. 16



FIG. 17

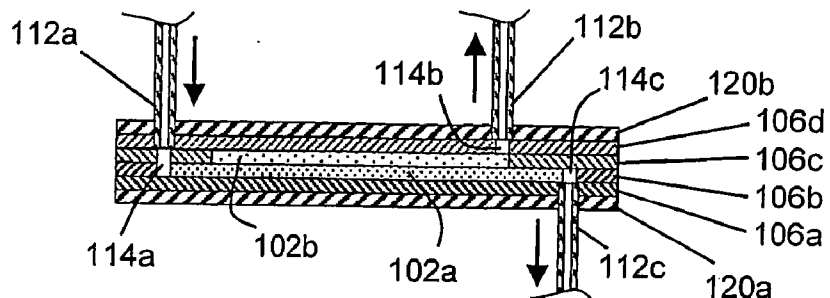

FIG. 18

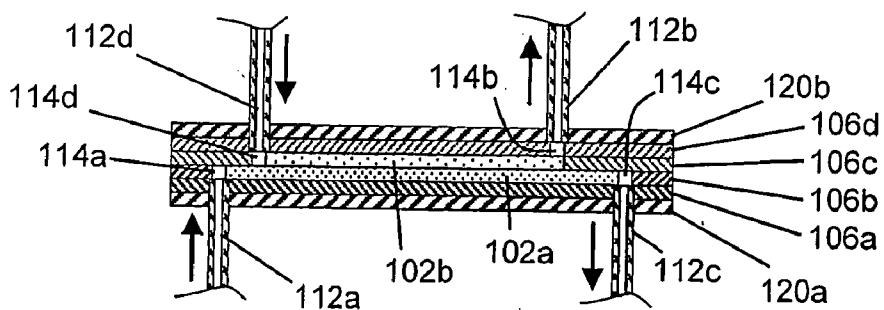

FIG. 19

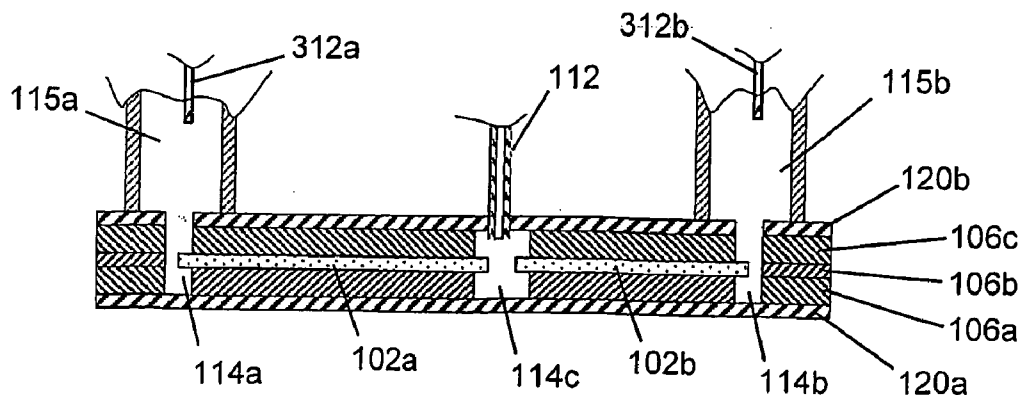

FIG. 20

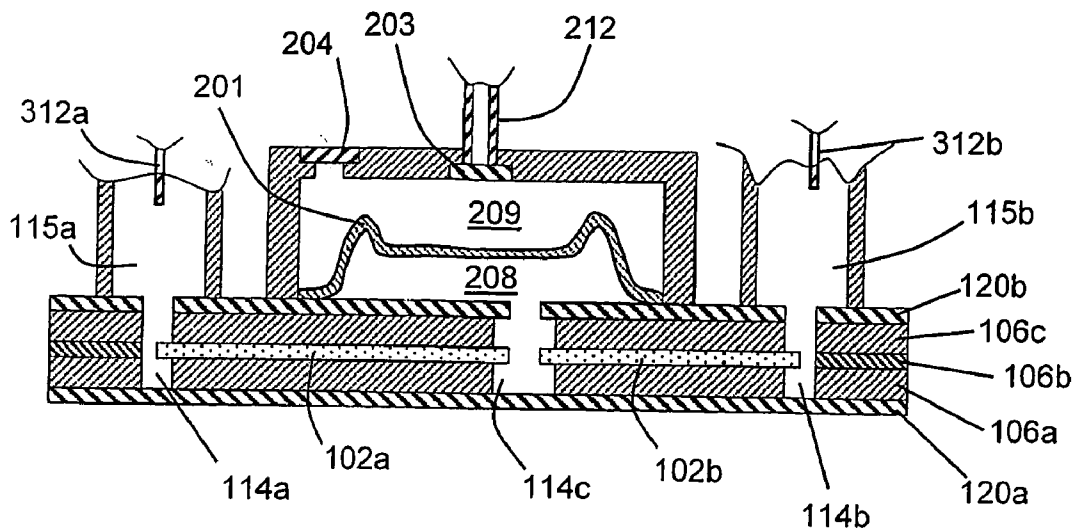

FIG. 21

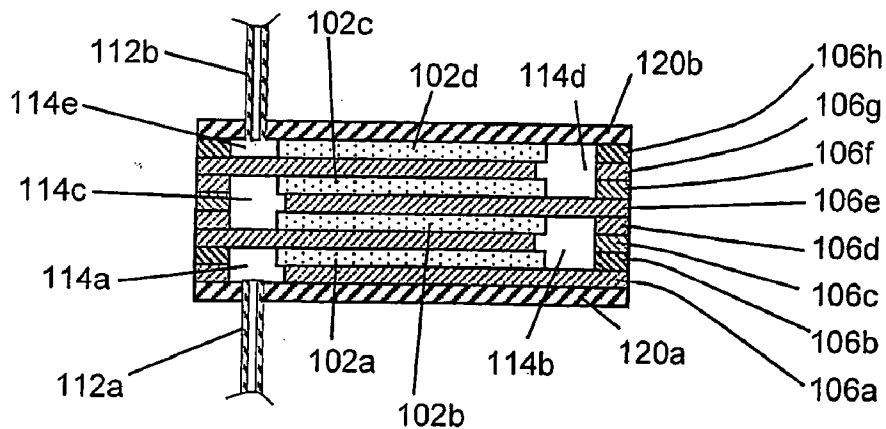

FIG. 22

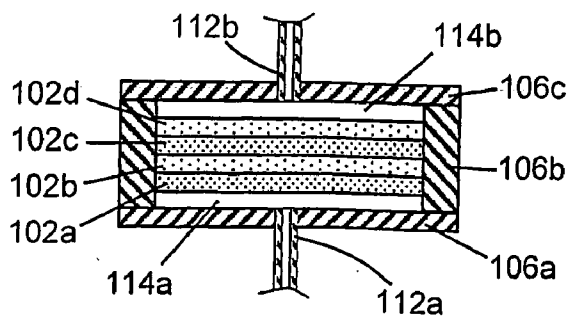

FIG. 23

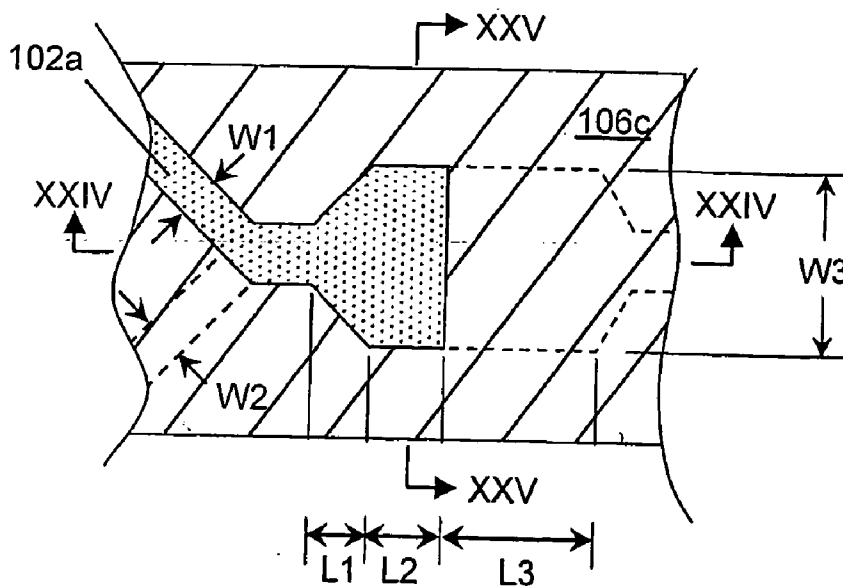

FIG. 24

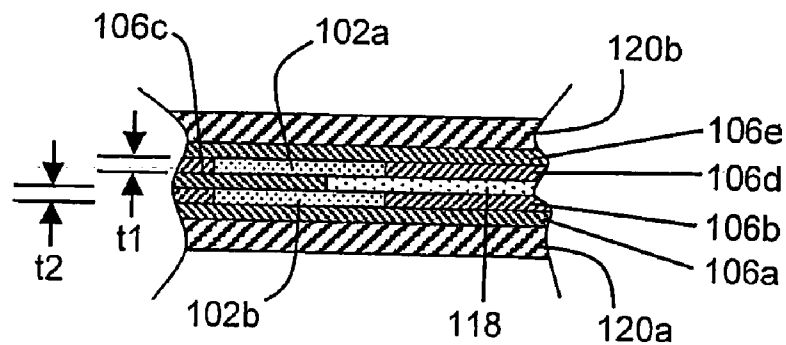

FIG. 25

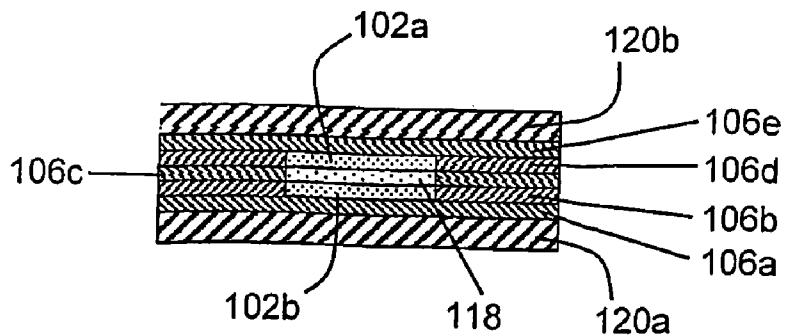

FIG. 26

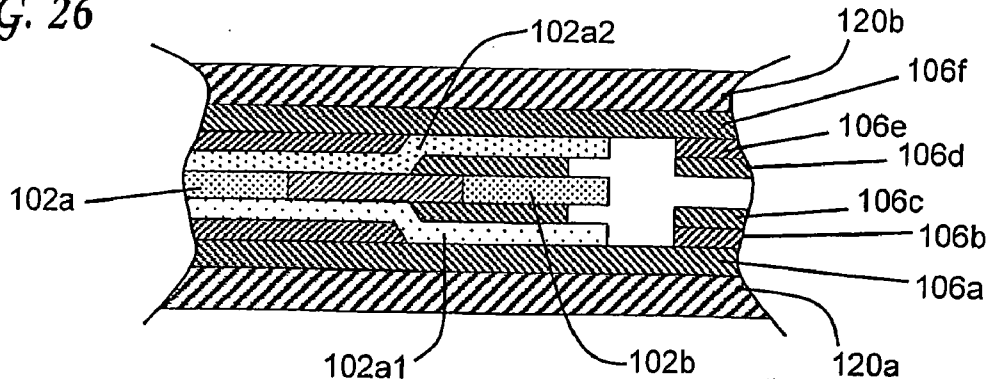

FIG. 27

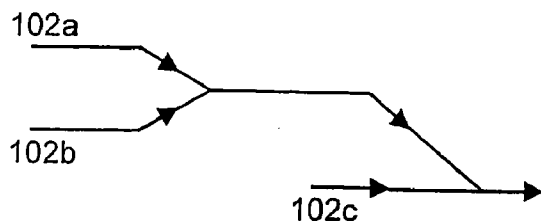

FIG. 28

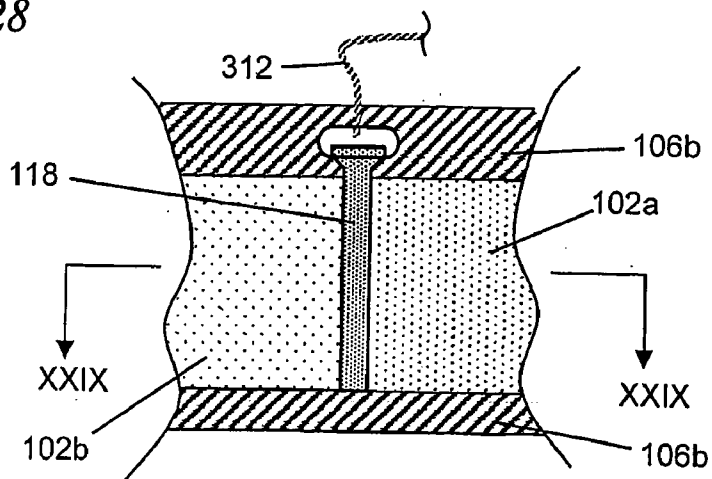
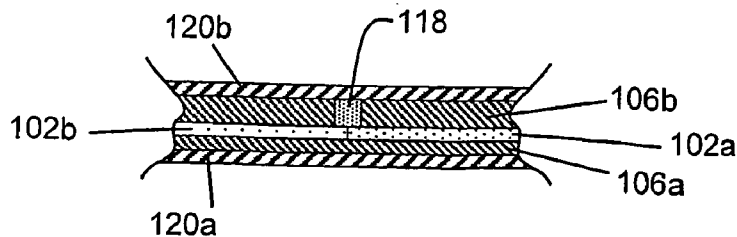

FIG. 29



FLOW DEVICE

RELATED APPLICATION DATA

[0001] This application is a continuation-in-part of our application Ser. No. 10/198,223, filed Jul. 17, 2002 (Docket No. 14138), the entire disclosure of which is incorporated herein by reference.

FIELD OF THE INVENTION

[0002] This invention relates to flow devices.

BACKGROUND OF THE INVENTION

[0003] Many systems make use of flow devices, including micro-flow devices, which include a conduit through which there is electroosmotic and/or pressure-driven flow of a liquid. Such systems include, for example, chromatography systems, including high-performance liquid chromatography (HPLC) systems, electrokinetic (also known as electroosmotic) pumping systems, chemical processing systems, and electrophoretic separation systems. Reference may be made for example to U.S. Pat. Nos. 6,074,725, 6,156,273, 6,176,962 and 6,287,440, and International Publication Nos. WO 99/16162 and WO 02/101474, the entire disclosures of which are incorporated herein by reference for all purposes.

[0004] It is often desirable, for example in order to increase the surface-to-volume ratio of the conduit and/or to provide different surface chemistry, to fill the conduit with a fluid-permeable packing material. In the known methods, the packing material is placed in the conduit (i) in the form of loose particles or (ii) as a liquid polymeric composition which is cured in the conduit. These methods suffer from various disadvantages, for example the need to prevent the packing materials from falling out of the channel and/or falling into adjacent channels or other components; shrinkage of the polymeric compositions when they cure; and the difficulty of changing the surface chemistry of a packing material after it has been placed in the channel.

SUMMARY OF THE INVENTION

[0005] We have discovered, in accordance with the present invention, a wide variety of novel flow devices which make use of solid porous materials as liquid flow media. The invention is particularly useful when pre-shaped porous materials are used to provide conduits in flow devices, but the invention is not limited to pre-shaped porous materials. The term "pre-shaped" is used to denote a member having a shape before it is enclosed by the barrier member, as distinct from a member which is shaped within the conduit. The porous materials are often laminar, but can be of any shape. The term "laminar" is used in this specification to include, but is not limited to, planar. Thus, a laminar member can for example be a planar member of constant thickness, a planar member of regularly or irregularly varying thickness, a curved member of constant thickness, or a curved member of regularly or irregularly varying thickness. The periphery of a laminar member can be of any shape, and a laminar member can comprise one or more windows of any shape, i.e. areas within the periphery in which there is no material.

[0006] In a first aspect, this invention provides a novel flow device comprising a conduit which comprises

[0007] (1) a barrier member, and

[0008] (2) a porous flow member (PFM) which

[0009] (i) comprises a solid porous material, and

[0010] (ii) is enclosed by the barrier member so that the PFM comprises a flowthrough section through which there can be electroosmotic and/or pressure-driven flow of a liquid;

[0011] the device having at least one of the following characteristics

[0012] (A) the barrier member comprises a plurality of laminar barrier layers which have been laminated together around the PFM;

[0013] (B) the PFM is a pre-shaped PFM, or, if the device comprises more than one said conduit, the PFM in at least one of said conduits, e.g. the PFM in each of said conduits, is a pre-shaped PFM;

[0014] (C) the PFM is laminar and lies in a first plane, and the device comprises a conduit which (i) is in fluidic communication with the PFM, and (ii) lies in the first plane or in a plane substantially parallel to the first plane;

[0015] (D) the PFM is laminar and lies in a first plane, and the device comprises an electrode which (i) when the device is filled with an ionic liquid, is in electrical communication with the PFM, and (ii) lies in the first plane or in a plane substantially parallel to the first plane;

[0016] (E) the device comprises at least four laminar layers, at least two of the laminar layers comprising a laminar PFM;

[0017] (F) the device comprises

[0018] (1) a first said conduit comprising a first barrier member and a first PFM which comprises a first flowthrough section and a first transfer section, the first flowthrough section being enclosed by the first barrier member so that fluid can flow the first flowthrough section and into the first transfer section,

[0019] (2) a second said conduit comprising a second barrier member and a second PFM which comprises a second flowthrough section and a second transfer section, the second flowthrough section being enclosed by the second barrier member so that fluid can flow through the first flowthrough section and into the second transfer section;

[0020] the first and second transfer sections

[0021] (a) having overlapping surfaces which

[0022] (i) contact each other directly, or

[0023] (ii) are adjacent to each other and are separated from each other by a gap which optionally is filled by a porous material, and

[0024] (b) being enclosed by a third barrier member so that liquids flowing into the first and second transfer sections are mixed together;

[0025] (G) the device comprises

- [0026] (1) a first said conduit in which the flowthrough section of the PFM is a first laminar PFM which lies in a first plane,
- [0027] (2) a second said conduit in which the flowthrough section of the PFM is a second laminar PFM which lies in a second plane parallel to first plane and which overlaps the flowthrough section of the first conduit;
- [0028] (H1) the PFM comprises
- [0029] (a) a first layer which is composed of a first porous material,
- [0030] (b) a second layer which is in contact with the first layer along an interface and which is composed of second porous material,
- [0031] the first porous material having a first pore size and second porous material having a second pore size which is larger than the first pore size, or the pore geometry of the first porous material at the interface being such that particles above a certain pore size will not pass through the interface, and the device further comprises
- [0032] (3) a fluidic inlet which communicates with the second layer but not with the first layer,
- [0033] (4) a first fluidic exit which communicates with the first layer but not with the second layer, and
- [0034] (5) a second fluidic exit which communicates with second layer but not with the first layer;
- [0035] (H2) the PFM is composed of a porous material having an asymmetric pore size distribution such that the pore size increases, regularly or irregularly, across the thickness of the PFM, whereby the PFM has a first surface composed of relatively small pores and a second surface composed of relatively large pores, and the device further comprises
- [0036] (3) a fluidic inlet which communicates with the PFM,
- [0037] (4) a first fluidic exit which communicates with the first surface but not with the second surface, and
- [0038] (5) a second fluidic exit which communicates with second surface but not with the first surface;
- [0039] (I) the device comprises
- [0040] (1) a first said conduit in which the PFM comprises a first solid porous material having a first zeta potential, the first conduit having a first inner end and first outer end,
- [0041] (2) a second said conduit in which the PFM comprises a second solid porous material having a second zeta potential which is substantially different from the first zeta potential, the second conduit having a second inner end and a second outer end,
- [0042] (3) an inner fluidic junction which communicates with the first and second inner ends,
- [0043] (4) a first outer fluidic junction which communicates with the first outer end, and
- [0044] (5) a second outer fluidic junction which communicates with the second outer end;
- [0045] (J) the device comprises
- [0046] (1) a first said conduit in which the flowthrough section of the PFM terminates at a first cross-sectional end surface;
- [0047] (2) a second said conduit in which the flowthrough section of the PFM terminates at a second cross-sectional end surface which contacts the first surface at a butt junction; and
- [0048] (3) an auxiliary porous member which contacts the sides of the first and second PFMs and bridges the buff junction;
- [0049] (K) the PFM has a cross-section having a thickness of less than 4000 microns, for example less than 600 microns e.g. 20 to 600 microns, preferably 50 to 250 microns;
- [0050] (L) the PFM has a cross-section having an equivalent diameter of less than 4000 microns, for example less than 1500 microns;
- [0051] (M) the conduit is rigid.
- [0052] In a second aspect, this invention provides a method of causing pressure-driven and/or electroosmotic flow through a device according to the first aspect of the invention, the method comprising
- [0053] (1) applying an electrical potential to an ionic liquid in a flow device according to the first aspect of the invention; and/or
- [0054] (2) exerting pressure on a liquid to cause it to flow through the PFM of a flow device according to the first aspect of the invention.
- [0055] In method (1), the electrical potential can cause the ionic liquid to flow through the PFM and/or through another component of the device. Thus, in one embodiment of the invention, the PFM is part of a bridge which serves as an electrical connection and there is little or no electroosmotic flow of ionic liquid through the PFM. The pressure in the device depends upon the way in which the device is being used, and the device should be such that it will operate safely at that pressure. For example, the device may be such that it will operate at pressures up to about 15 psi (1 kg/cm²) or up to about 500 psi (35 kg/cm²).
- [0056] In a third aspect, this invention provides a method of preparing a flow device comprising a conduit, preferably a novel conduit according to the first aspect of the invention, which comprises
- [0057] (1) a barrier member, and
- [0058] (2) a porous flow member (PFM) which
- [0059] (i) comprises a solid porous material, and
- [0060] (ii) is enclosed by the barrier member so that the PFM comprises a flowthrough section through which there can be electroosmotic and/or pressure-driven flow of a liquid;
- [0061] the method comprising

[0062] (A) laminating the flowthrough section of the PFM between a plurality of barrier layers which are thus laminated together to form the barrier member; or

[0063] (B) placing the flowthrough section of the PFM in a mold, placing a hardenable liquid composition in the mold around the PFM, and hardening the composition to encapsulate the flowthrough section.

BRIEF DESCRIPTION OF THE DRAWINGS

[0064] The Figures in the accompanying drawings, which are diagrammatic and not to scale, illustrate the invention. In the Figures, a component appearing in more than one Figure is identified by the same reference numeral in each Figure.

[0065] FIG. 1 is a plan view cross-section through a first device of the invention,

[0066] FIGS. 2 and 3 are end view and side view cross-sections taken on lines II-II and III-III of FIG. 1,

[0067] FIGS. 4-10 are partial cross-sections of other devices of the invention;

[0068] FIGS. 11, 14 and 15 are plan views of PFMs for use in the invention;

[0069] FIG. 12 is a cross-section on line XII-XII of FIGS. 11, 14 and 15;

[0070] FIG. 13 is a cross-section on line XIII-XIII of FIGS. 11 and 14;

[0071] FIG. 16 is a cross-section on line XVI-XVI of FIG. 15;

[0072] FIGS. 17-22 are cross-sections of other devices of the invention,

[0073] FIG. 23 is a partial plan view cross-section through a mixing device of the invention,

[0074] FIGS. 24 and 25 are end view and partial side view cross-sections taken on lines XXIV-XXIV and XXV-XXV of FIG. 23,

[0075] FIG. 26 is a partial cross-section of another mixing device of the invention;

[0076] FIG. 27 is a flow diagram of a two-stage mixing device of the invention;

[0077] FIG. 28 is a partial plan view cross-section of a butt joint between two PFMs; and

[0078] FIG. 29 is a partial side view cross-section on line XXIX-XXIX of FIG. 28.

DETAILED DESCRIPTION OF THE INVENTION

[0079] In the Summary of the Invention above and in the Detailed Description of the Invention, the Examples, and the claims below, and in the accompanying drawings, reference is made to particular features of the invention. It is to be understood that the disclosure of the invention in this specification includes all appropriate combinations of such particular features. For example, where a particular feature is disclosed in the context of a particular aspect or embodiment of the invention, or a particular Figure, or a particular claim, that feature can also be used, to the extent appropri-

ate, in combination with and/or in the context of other particular aspects and embodiments of the invention, and in the invention generally.

[0080] The term “comprises”, and grammatical equivalents thereof, are used herein to mean that other components, ingredients, steps etc. are optionally present in addition to the component(s), ingredient(s), step(s) specifically listed after the term “comprises”. The term “at least” followed by a number is used herein to denote the start of a range beginning with that number (which may be a range having an upper limit or no upper limit, depending on the variable being defined). For example “at least 1” means 1 or more than 1, and “at least 80%” means 80% or more than 80%. The term “at most” followed by a number is used herein to denote the end of a range ending with that number (which may be a range having 1 or 0 as its lower limit, or a range having no lower limit, depending upon the variable being defined). For example, “at most 4” means 4 or less than 4, and “at most 40%” means 40% or less than 40%. When, in this specification, a range is given as “(a first number) to (a second number)” or “(a first number)-(a second number)”, this means a range whose lower limit is the first number and whose upper limit is the second number. Where reference is made herein to “first” and “second” components, e.g. first and second conduits, this is generally done for identification purposes; unless the context requires otherwise, the first and second components can be the same or different.

[0081] PFM Shapes

[0082] The PFM can be straight, or regularly or irregularly curved, the curve being a smooth curve and/or a succession of straight sections at an angle to each other, in two or three dimensions. When the PFM is obtained by division of a sheet of porous material, it is easy to prepare PFMs of different shapes, for example straight strips of constant or varying width, (e.g. with flared end sections), strips which are part of a circle, strips which bend through an angle of at least 360°, for example so that the fluid path includes two or more sections which are substantially parallel to each other and are substantially the same distance (measured directly, not along the liquid flow path to) from the inlet, e.g. strips in the form of a smooth or angular spiral or zigzag, so that a long conduit becomes more compact. When the sheet of porous material is flexible, a strip divided from it can be bent so that it is no longer flat. The cross-section of the PFM (i.e. a section at right angles to the local axis of the PFM) can be of any shape. When the PFM is obtained by division of a sheet of porous material, the cross-section will generally be rectangular (including square), but may be more complex if the sheet is not of constant thickness. One or both end sections of the PFM can have a cross-section different from the intermediate portion of the PFM. The end sections can be the same or different. The porous material can extend out from the barrier member, for example by a distance of 1 to 3 mm, be flush with the end of the barrier member, or terminate within the barrier member.

[0083] PFM Materials

[0084] The PFM can comprise any solid porous material that will provide a conduit having desired physical and electrical properties. The PFM can consist of the porous material, or can also include one or more auxiliary components having substantially no effect on the fluid flow through the porous material. For example, an auxiliary component

can surround, or be surrounded by, or form a layer adjacent to, the porous material, and can provide desired strengthening, electrical or protective properties. Thus, in one embodiment of the invention, the PFM is a tube of circular, rectangular (including square) or other cross-section, e.g. a conventional capillary tube, into which the porous material has been placed. In this embodiment, because the tube is surrounded and supported by the barrier material, there is no need to use the specialized fittings currently needed to support the ends of such tubes. In addition, the tube can be such that, if it was used without the barrier material, it would be too delicate, for example would not be sufficiently strong to withstand the internal pressure in the tube.

[0085] The PFM can comprise a single layer of porous material or two or more layers of porous material. When there are two or more layers, the layers can be the same or different, and can be arranged so that the liquid flows through them simultaneously or sequentially, and/or, if the layers are different, so that different components of the liquid follow different paths. The layers can be in contact with each other or separated from each other by an auxiliary member which may be permeable or impermeable to the liquid or permeable to one or more components of the liquid and impermeable to one or more other components of the liquid.

[0086] Many porous materials are readily available as self-supporting sheets of uniform thickness, preferably 20-600 microns, particularly 50-250 microns, e.g. about 100 microns. PFMs can be divided, e.g. by machining, die-cutting or kiss-cutting, from such sheets. Available materials include, for example, porous sheets which are based on polymers (but which may also contain other ingredients, for example fillers), or inorganic materials, for example silica, alumina and other ceramics.

[0087] Factors to be considered in the choice of porous material include surface chemistry, surface charge, pore size, pore topology, and formation factor, in conjunction with the system in which the conduit is to be employed. Porous

a conduit such that at least a component of the liquid flow is in the direction of the pores. In some ultra-filtration membranes, the pore size distribution is highly asymmetric in the direction normal to the membrane. A PFM divided from such a membrane can be used in a separation device as described in paragraph (H2) of The first aspect of the invention. Depending on the type of device, it may be preferable to use a material having a low surface charge density, preferably less than 10^{13} , for example about 10^{12} , charges/cm², or a material having a high surface charge density, preferably greater than 10^{14} , for example greater than 5×10^{14} , charges/cm². For example, hydrophilic polyvinylidene fluoride (PVDF), polyether sulfone and polyvinyl alcohol, are suitable for bridges; polyamides, nitrocellulose, and sulfonated polytetrafluoroethylene (PTFE) membranes are suitable in ion-exchange elements; and modified PVDF, modified polyamides, modified polyetherether ketones, silica, and alumina are suitable for electrokinetic pumps. Hydrophobic materials, e.g. polypropylene and other polyolefins, and PTFE, are suitable for vents.

[0089] In some cases, available porous sheet materials are immediately usable in the present invention. In other cases, better results can be obtained by further treatment of the available materials, either in sheet form or as PFMs which have been divided from them. One useful treatment is to derivativize the material to modify its surface, e.g. to enhance or add surface charge or to change its chemistry. Such treatments are well-known to those skilled in the art, but are very difficult to apply to packing materials that are already in place in a conduit. Reference may be made, for example, to *Macromolecules* 31, 1277-1284 (1998), Jimbo et al, *J. Membrane Sci* 179, 1-27 (2000), Takata et al and *J. Membrane Sci* 139, 101-107 (2000), Belfer et al.

[0090] The preferred values of zeta potential and average pore size differ from one type and device to another. The Table below (in which the Debye length is denoted by the abbreviation X) gives further information.

| | EOF device | bridge element | non-electroosmotic device |
|-------------------|---|---|---|
| Zeta potential | Higher values are generally preferred, e.g. >20 mV or >50 mV. | Preferably dependent on the zeta potential of the EOF elements in series with the bridge element, for example <20 mV or <10 mV. | Lower values are generally preferred, e.g. <10 mV or <5 mV. |
| Average pore size | preferably >10 λ or >20 λ . The preferred upper limit depends on the required stall pressure; smaller pore sizes are preferred for higher stall pressures, e.g. <500 nm or <150 nm. | Preferably dependent on the pore size of the EOF elements in series with the bridge element, e.g. <100 nm or <50 nm. | Preferably dependent on the desired pressure drop at a particular flowrate, e.g. from 200 nm to 10 micrometers. |

materials suitable for use in this invention include materials in which the average pore size is less than 10 micron or less than 1 micron, for example materials in which all the pores have a size less than 10 or less than 1 micron.

[0088] When the pore geometry of the sheet is isotropic, a PFM can be divided from the sheet without regard to the intended direction of liquid flow. When the pore geometry is anisotropic, a PFM divided from the sheet must be used in

[0091] PFM Dimensions

[0092] The terms length (L), width (w) and thickness (t) are used to denote the dimensions of the flowthrough section of the PFM (which may be the whole of the PFM), i.e. the part of the PFM which is enclosed by the barrier member. Thus, if end sections of the PFM extend beyond the barrier member into a junction or reservoir, those end sections are not considered in determining L, w and t. For PFMs whose

cross-section at right angles to the axis of fluid flow is a rectangle, w and t denote the dimensions of the longer and shorter sides of the rectangle, respectively. In many cases, PFMs having a rectangular cross-section are preferred. For PFMs having non-rectangular cross-sections, w and t refer to the longer and shorter sides of the rectangle of minimal area which can be drawn around the non-rectangular cross-sections. For PFMs whose cross-section varies, w and t refer to the effective average value, taking into account the lengths of the PFM having particular values of w and t . Thus, for a PFM of constant thickness and varying width, the effective average value of w is the inverse of the average of the inverse of w along the length of the PFM.

[0093] When the PFM is composed of a single layer of porous material, its thickness, (or average thickness, if the thickness varies) may be for example 20 to 600 microns, preferably 50 to 250 microns, e.g. 75 to 150 microns. When the PFM is composed of a number of components, each component preferably has such a thickness. Thus, a PFM comprising two or more layers of porous material stacked on top of each other may have a thickness of, for example, 200 to 2000 microns. The term equivalent diameter, d , is used in defining the cross-section of the PFM (or the average value of the equivalent diameter if the cross-section varies). d is the diameter of a circle having the same area as the cross-section of the PFM. Thus, for rectangular cross-sections $d = \sqrt{4 wt/\pi}$.

[0094] In many embodiments of the invention, L is substantially greater than either of w and t . L is for example at least 3 times or at least 5 times, e.g. 3 to 100 times or 5 to 30 times the equivalent diameter, d . In many embodiments of the invention, especially those in which the PFM has a rectangular cross-section, w and t are such that the value of the ratio w/t is at least 3, at least 10 or at least 20, for example 3 to 200, 5 to 100, or 8 to 75. The width w may be for example 0.2-2 mm.

[0095] Barrier Members

[0096] The conduits of the invention are constructed so that, in use, a liquid follows a desired flow path through the flowthrough section of the PFM. Thus, each PFM must be enclosed along its boundaries, but not at its inlet(s) and outlet(s), by a barrier member which is not permeable to the liquid. The barrier member can be monolithic or composed of two or more barrier components or layers secured together. A preferred method of providing the barrier comprises laminating a PFM, generally a laminar PFM, between barrier components, generally laminar, barrier components. One or more of the barrier components can be pre-shaped in two or three dimensions to conform to the PFM, making allowance when necessary for deformation of the barrier components during the lamination. For example, windows and/or channels can be formed in the barrier components. The barrier components can be such that they can be secured to each other and to the PFM by lamination using heat and pressure. Suitable polymeric films, with bonding temperatures from 80 to 350° C. are well-known. Alternatively or additionally, lamination can be affected with the aid of adhesives. In another embodiment, the barrier member is provided by a liquid barrier composition which is placed around the PFM and then solidified. Examples of such compositions include potting compositions which cure at room temperature or with the aid of heat or ultraviolet,

ultrasonic or other radiation, and which may contain fillers, e.g. reinforcing fibers, e.g. compositions based on epoxies, polyphenylene oxides, acrylic resins and silicones. In another embodiment, the barrier member is prepared by wrapping a flexible barrier film or tape around the PFM, and optionally treating, e.g. heating, the wrapping. Alternatively or additionally, mechanical means can be used to secure the barrier member around the PFM.

[0097] The barrier components and the way in which they are secured around the PFM should be such that the PFM is not penetrated by the barrier material or otherwise physically or chemically damaged. If need be, a protective layer can be placed between the PFM and the barrier component(s).

[0098] The conduits of the invention preferably have physical properties such that they can be conveniently handled and used, including the ability to withstand the fluid pressure within the conduit, which can vary widely between different types of system. Such physical properties may be provided by the barrier member alone. Alternatively or additionally, the device can include one or more support members, e.g. of metal or glass, to provide desired physical properties. Generally the conduits of the invention are rigid, i.e. do not bend or flex in use. However, the conduit can be flexible.

[0099] Additional Components

[0100] The devices of the invention can include a wide variety of additional components, for example junctions and capillaries through which, in use, liquids enter or leave an inlet, outlet or an intermediate point of the PFM; reservoirs for liquids; electrodes; electrode leads; pumps, and optical and/or electrical components for monitoring the system. Such additional components can be incorporated into the device at the same time as the barrier member is placed around the PFM, for example by placing them between layers which are secured together as part of a lamination process. Alternatively, or additionally, they can be added after the barrier member has been placed around the PFM, for example by creating vias in the barrier member(s) and/or support member(s), inserting the additional component and sealing the via around the additional component. The fluidic junctions in the devices of the invention preferably have a low dead volume.

[0101] Devices and Systems

[0102] The conduits of the invention can form a part of, or be used in association with, a wide variety of flow devices, including, for example, devices for chromatographic separation, devices for chemical processing, analytical devices, pumps, injectors, flow controllers, separation elements, bridges, reactors, mixers, and detection elements, including the devices disclosed in copending commonly assigned U.S. patent application Ser. Nos. 10/137,215, 10/155,474, 10/273,723 and 10/322,083, and International Patent Applications PCT/US 02/19121 (published as International Publication Number WO 02/101474) and PCT/US 03/13315, the disclosures of which are incorporated herein by reference.

[0103] Multilayer Devices

[0104] Many devices of the invention contain two or more, for example, at least 3 or at least 4, e.g. 3-6, laminar

PFMs, each PFM forming part of a layer in a multilayer device. Each PFM-containing layer can contain one or more PFMs. The PFMs in different layers can be placed so that the major surfaces of adjacent PFMs completely overlap, partially overlap, or do not overlap. Adjacent PFM-containing layers can be separated from each other by a barrier layer, or can contact each other directly. When adjacent PFM-containing layers contact each other directly, and the PFMs overlap, the PFMs will contact each other. The liquid flows in the PFMs can be in the same direction or in different directions, including opposite directions. Different PFMs can be in fluid communication with each other through direct contact and/or because both communicate with the same fluidic junction. A multilayer device can contain two or more fluid systems which operate independently of each other, or fluid systems whose operation is dependent on the behavior of each other.

[0105] The mixing devices, the multilayer devices with two or more overlapping PFMs, and the filtration devices described below are particular examples of the multilayer devices of the invention.

[0106] Mixing Devices

[0107] One embodiment of the invention is a mixing device having characteristic (F) set out in the first aspect of the invention. Such mixing devices optionally can have one or more of the following characteristics:—

[0108] (F1) at least one, and preferably each, of the first and second PFMs comprises a flowthrough section having a width w_1 , and a transfer section which comprises

[0109] (i) a flared section in which the width increases to w_3 , the increase preferably being symmetrical about the flow axis, and w_3 preferably being from 2 to 4 times w_1 , and the length of the flared section preferably being from 0.3 to 0.7 times w_3 , and

[0110] (ii) a pre-mixing section which is adjacent to the flared section and which has the width w_3 , and which preferably has a length from 0.8 times to 2 times the length of the flared section;

[0111] however, in some cases, adequate mixing can be obtained with little or no flared section, the pre-mixing section then having a width of, for example, 1 to 1.5 times w_1 ;

[0112] (F2) the device includes a mixing member which

[0113] (i) is composed of a porous material having a pore size greater than the pore size of either of the PFMs, preferably a pore size which is at least 2 times, particularly at least 5 times, for example 5 to 20 times, the pore size of the PFM having the larger pore size; and

[0114] (ii) comprises an intermediate section which lies between and contacts the first and second transfer sections, and a continuation section which extends from the first and second transfer sections; the intermediate section and the continuation section preferably have the same width as the transfer sections; the length of the intermediate section is preferably 0.1 to 0.8 times the length of the pre-mixing

section; the length of the continuation section is preferably selected to provide the desired degree of mixing; and the end of the continuation section preferably has a reduced width suitable for making a conventional connection to the next fluidic stage of the device;

[0115] (F3) at least one of the PFMs is divided into two parts, each part having a flowthrough section and a transfer section, and the transfer sections of the first and second PFMs are interleaved with each other;

[0116] (F4) the area A between the overlapping transfer sections has an equivalent diameter d_{transfer} such that each of the ratios d_{transfer}/t_1 and d_{transfer}/t_2 is at least 5, preferably at least 10, more preferably at least 20, for example 10 to 200 or 20 to 100;

[0117] (F5) liquid flows in the first transfer section along a first flow axis and liquid flows in the second transfer section along a second flow axis, and the liquid flow in the second transfer section has a component parallel to the first flow axis, the component preferably being at least 50%, particularly at least 80%, of the flow.

[0118] The mixing device can be used for example, to mix two aqueous liquids, two organic liquids, or an aqueous liquid and an organic liquid. The liquids can be of different viscosities, may contain dissolved chemicals, including biochemicals, and may be dispersions of particulate materials or emulsions. The liquids can be miscible or immiscible, for example in order to produce an emulsion or as part of a chemical extraction, or can undergo a chemical reaction together. The solid porous material of the PFMs should be selected so that they are not damaged by, and do not damage, the liquids being mixed or the products of the mixing. The liquid flow can be one or both of pressure-driven flow and electroosmotic flow. The flowrates through the PFMs can be the same or different and can be constant or can vary.

[0119] Preferably, the PFMs and the dimensions of the device are selected so that the pressure drop over at least one, and preferably all, of the flowthrough sections is greater than, for example at least 2 times, preferably 5 to 15 times, for example about 10 times, the pressure drop between the mixing stage and the outlet

[0120] The mixing device can be used to mix three or more liquids simultaneously, by using a corresponding number of conduits having overlapping transfer sections. The mixing device can contain two or more mixing stages, for example a first mixing stage in which two different liquids are mixed, and a second mixing stage in which the product of the first mixing stage is mixed with a third liquid. In this way, for example, successive stages of a chemical synthesis can be carried out in the different mixing stages.

[0121] FIGS. 23 to 27 depict mixing devices of the invention.

[0122] Multilayer Devices

[0123] One embodiment of the invention is a multilayer device having the characteristic (G) as set out in the first aspect of the invention. Such a multilayer device optionally can have one or more of the following characteristics:—

[0124] (G1) the first and second laminar PFMs overlap each other in an overlap area, and one of the barrier

members is an intermediate barrier member which lies between the first and second PFMs, and which, over a substantial proportion, for example at least 70%, e.g. 90-100%, of the overlap area, prevents liquid from flowing between the first PFM and second PFM.

[0125] (G2) the device comprises a junction which is in fluidic communication with the first and second PFMs, the junction optionally comprising a porous material;

[0126] (G3) the device comprises at least 3, for example 3 to 6, laminar PFMs which lie in parallel but different planes.

[0127] Filtration Devices

[0128] One embodiment of the invention is a filtration device having characteristic (G1) or (G2) as set out in the first aspect of the invention. When a liquid containing relatively small molecules or particles of one type and relatively large molecules or particles of another type is passed through a layered PFM as defined in (G1) or a PFM having an asymmetric pore size distribution as defined in (G2), some of the smaller molecules or particles migrate to one surface of the PFM, and a product containing only the smaller molecules or particles can be recovered from that surface, while a product containing the larger particles and a smaller proportion of the smaller molecules can be recovered from the opposite surface. A liquid can be passed through the device to assist in recovery of the smaller molecules or particles. FIGS. 17 and 18 depict such devices.

[0129] Devices with Two PFMs Having Different Zeta Potentials

[0130] One embodiment of the invention is a device containing two PFMs having different zeta potentials, in particular a device having characteristic (I) as set out in the first aspect of the invention. Such devices can optionally have one or more of the following characteristics

[0131] (I1) the first and second zeta potentials have an opposite sign;

[0132] (I2) the first and second zeta potentials differ by at least 20, preferably at least 50, e.g. 50-100, mV, and

[0133] (I3) the device includes

[0134] (i) a first chamber communicating with the inner fluidic junction and having a wall which comprises a flexible diaphragm, and

[0135] (ii) a second chamber having a wall which comprises the flexible diaphragm.

[0136] When such a device is filled with a suitable ionic liquid and electrical current flows between the electrodes, the direction of liquid flow depends upon the zeta potentials. If the zeta potentials are of opposite sign, the liquid flow in each of the PFMs is towards the central junction when the current flows in one direction, and away from the central junction when the current flows in the opposite direction. If the zeta potentials are of the same sign, the liquid flow in each of the PFMs is in the same direction, with the direction depending on the direction of the current. The rate of flow in each PFM depends on a variety of factors, including the sign and size of the zeta potentials. There is, therefore, a net flow of liquid to or from the central junction. In this device,

the electrodes can be in ambient pressure reservoirs from which gaseous by-products can easily be vented. When the device has feature (13) above, it can be used to pump a liquid in the second chamber. The liquid in the second chamber need not be a liquid which will support proper electroosmotic flow; for example it can be a liquid containing polyvalent ions, a liquid having very high conductivity, or a liquid containing a substance which is damaged by electrical current.

[0137] Butt Junctions Between PFMs

[0138] When two PFMs are butted together at a fluidic junction, the area of contact between them is limited to the smaller of the two PFM cross-sections (or a somewhat larger, but still small, area if the ends of the PFMs are shaped to fit each other). Consequently, there may be substantial resistance to the movement of liquid out of an outlet of the junction. In addition, there is a danger that, during preparation of the device, the junction between the PFM will be partially blocked by liquid barrier material. In one embodiment of the invention, these problems are ameliorated through the use of at least one auxiliary porous member which contacts the sides of the PFMs and bridges the butt joint between them. The auxiliary porous member is preferably made of a porous material having a pore size greater than the pore size of either of the PFMs; preferably a pore size which is at least 2 times, particularly at least 5 times, for example 5 to 20 times, the pore size of the PFM having the larger pore size.

[0139] Preparation of the Devices

[0140] The devices of the invention can be prepared by either of, or a combination of, the methods included in the definition above of the third aspect of the invention. Before the barrier is placed around the PFM, a wide variety of additional components, e.g. capillary tubes, electrodes, electrode leads, optical and/or electrical monitoring components, preformed junctions and preformed reservoirs, can be assembled in contact with and/or separated from, the PFM, and thus incorporated into the device, at the same time as the barrier is placed around the flowthrough section of the PFM. In many cases, lamination of a plurality of barrier layers is the preferred method. The additional components can be placed between two barrier layers and/or between a barrier layer and a PFM. Especially when the device comprises two or more PFMs, the device can be prepared in two or more successive steps, the steps being the same or different.

[0141] Wetting Procedures

[0142] When the devices of the invention are in use, they are filled with a liquid. When the flow of liquid is solely pressure-driven, any appropriate liquid can be used. When the flow is at least partly electroosmotic flow, the liquid must be an ionic liquid. It is, therefore, desirable to design the devices so that they can be easily wetted without trapping air pockets. The device can be filled with a liquid after it has been made (and after sterilization, if needed). In some cases parts of the device can be wetted while the device is being made. After it has been wetted, a device can be sealed and stored until it is needed. Methods of wetting flow devices are well-known to those skilled in the art.

[0143] The Drawings

[0144] FIGS. 1-3 show a device which can be used as part of an electrokinetic pumping system or as part of a combined

electroosmotic and pressure-driven flow system. In FIGS. 1-3, PFM 102 is composed of a solid porous material and comprises a flowthrough section having a length L , a width w and a thickness t , and terminal transfer sections which extend into junctions 114a and 114b. Porous members 118a and 118b provide bridges between junction 114a and a reservoir 115a, and between junction 114b and a reservoir 115b, respectively. Porous members 118a and 118b can be conventional conduits, or conduits of the invention. Insulating barrier layers 106a, 106b and 106c and support members 120a and 120b encapsulate the porous members 102, 118a and 118b, and define the junctions 114a and 114b and the reservoirs 115a and 115b. Electrodes 312a and 312b pass into the reservoirs 115a and 115b respectively. Capillaries 112a and 112b pass through sealed vias in support member 120b into junctions 114a and 114b respectively. In use, the electrodes are connected to a power source, an ionic liquid is placed throughout the device, and an ionic liquid flows through the capillary 112a, the PFM 102 and the capillary 112b. The liquid in the reservoirs serves to carry current and little or none of it flows through PFM 102.

[0145] In FIG. 4, capillary 112a and electrode 312a are placed between PFM 102 and barrier layer 106c, and are covered by nonporous member 306 to ensure proper fluidic and electrical connection to PFM 102. In FIGS. 5 and 6, barrier layers 106a, 106b and 106c are shaped so that PFM 102 extends into a well 416 to which there is access through via 116 in support member 120b. In FIG. 7, PFM 102 and the barrier layers 106a, 106b and 106c are shaped so that the via 116 communicates directly with the PFM 102. In FIG. 8, transducer 406 is secured below support member 120a by barrier layer 106d, and forms a lower well 417 which communicates with the well 416 through a via 117 in support member 120a. In FIG. 9, the end of the PFM 102 is placed in a reservoir 115 containing liquid 121. As shown in FIG. 9, the end of the PFM 102 is flush with the ends of the barrier and support members. In alternative embodiments, the PFM 102 can extend beyond, or be terminated short of, the ends of the barrier and support members. In FIG. 10, optical fibers or electrodes 803a and 803b are placed opposite each other so that fluid flowing through the device passes between them and can be examined by passing light or electrical current between them.

[0146] FIGS. 11-13 show a simple PFM for use in the invention. FIGS. 12, 13 and 14 show a PFM having flared ends. FIGS. 12, 15 and 16 show a PFM which is shaped so that three sections of the PFM lie in the same plane and overlap each other transversely.

[0147] FIGS. 17 and 18 show devices which can be used to achieve partial separation of molecules or particles of different sizes. A liquid containing relatively small molecules or particles of one type and relatively large molecules or particles of another type enters inlet junction 114a through capillary 112a. The junction 114a communicates with a PFM comprising a first layer 102a having a relatively large pore size such that both types of molecule or particle will pass through it. In contact with first layer 102a, but not communicating with junction 114a is a second layer 102b having a smaller pore size such that only the small molecules or particles passing through the layer 102a will migrate through the interface into layer 102b. A product containing only the smaller molecules or particles is recovered from outlet junction 114b through capillary 112b, and a product

containing all the large molecules or particles and a reduced proportion of the small molecules or particles is recovered from outlet junction 114c through capillary 112c. In FIG. 18, a liquid is introduced through capillary 112d and junction 114d to layer 102b, and assists in the removal of the smaller molecules or particles.

[0148] FIG. 19 shows a device in which PFMs having different zeta potentials are used to convey a liquid from each end of the device towards the center, or vice versa. PFM 102a has a first zeta potential and communicates at one end with junction 114a and at the other end with junction 114c. PFM 102b has a second zeta potential and communicates at one end with junction 114b and at the other end with junction 114c. The first and second zeta potentials differ substantially, and may be of the same or different signs. Reservoir 115a containing electrode 312a communicates with junction 114a. Reservoir 115b containing electrode 312b communicates with junction 114b. Capillary 112 communicates with junction 114c. The device operates as previously described.

[0149] FIG. 20 is the same as FIG. 19, except that closed chambers 208 and 209, separated by flexible diaphragm 201, are on top of the central junction 114c. The liquid pumped into or out of chambers 208 changes the shape of the diaphragm 201, and thus pumps liquid in chamber 209. Chamber 209 is fitted with a septum or valve 204 for the introduction of liquid into the chamber, and an outlet 212 fitted with filter 203.

[0150] FIG. 21 shows a device having four PFMs, 102a, 102b, 102c and 102d, and barrier layers 106a-h arranged so that liquid introduced through capillary 112a flows consecutively through junction 114a, PFM 102a, junction 114b, PFM 102b, junction 114c, PFM 102c, junction 114d, PFM 102d, and junction 114a, and then exits through capillary 112b.

[0151] FIG. 22 shows a device having four PFMs, 102a, 102b, 102c and 102d stacked one on top of each other, and barrier layers 106a-h arranged so that liquid introduced through capillary 112a flows consecutively through junction 114a, through the PFMs at right angles to the planes thereof, and junction 114b, and then exits through capillary 112b.

[0152] FIGS. 23-25 show a mixing device comprising two PFMs (102a, 102b). Each PFM is of constant thickness (t_1 , t_2) and has a flowthrough section of constant width (w_1 , w_2) and a transfer section. The transfer section is made up of a flared section in which the width increases to w_3 over a length L_1 and a pre-mixing section of constant width w_3 and length L_2 . Sandwiched between the ends of the two pre-mixing sections is a mixing member 118 having a width w_3 which is maintained for a length L_3 sufficient to achieve a desired degree of mixing.

[0153] FIG. 26 shows part of a mixing device which comprises two PFMs 102a, 102b. PFM 102a is divided into two overlapping parts (102a1, 102a2), each having a flowthrough section and a transfer section which may be as shown in FIGS. 23-25. PFM 102b is placed between the overlapping parts (102a1, 102a2). Liquids flowing through the two PFMs are delivered to an open mixing chamber and discharged.

[0154] FIG. 27 is a flow diagram showing how liquids flowing through two PFMs 102a, 102b can be mixed with

each other, and the product of mixing in turn mixed with liquid flowing through PFM 102c.

[0155] FIGS. 28 and 29 show a butt joint between two PFMs 102a, 102b. An auxiliary porous member 118 bridges one side of the butt joint.

[0156] The following Examples illustrate the invention.

EXAMPLES 1-3

[0157] Three devices as illustrated in FIG. 19 were constructed using first and second PFMs having the characteristics shown in the Table below, the dimensions of L, w and t being in mm. In each Example, the effective pore size of the first PFM was 240 nm and the effective pore size of the second PFM was 300 nm.

| Example # | First PFM | | | | Second PFM | | | |
|-----------|-----------|-----|-----|------|------------|-----|------|------|
| | L | w | t | Zeta | L | w | t | Zeta |
| 1 | 10 | 5 | 0.1 | +50 | 10 | 2.1 | 0.12 | -30 |
| 2 | 10 | 5 | 0.1 | +50 | 5 | 8 | 0.2 | +2 |
| 3 | 10 | 2.3 | 0.1 | -35 | 8.75 | 2.3 | 0.09 | +27 |

EXAMPLE 4

[0158] A mixing device as shown in FIGS. 23-25 was prepared. The dimensions of the device, as identified in FIGS. 23-25 and given in mm, are shown in the table below. Each of the PFMs was a hydrophilic PVDF membrane having effective pore size of about 800 nm. The mixing member was a hydrophilic PVDF membrane having an effective pore size of about 6000 nm and a thickness of 0.1 mm.

| W ₁ | W ₂ | W ₃ | L ₁ | L ₂ | L ₃ | t ₁ | t ₂ |
|----------------|----------------|----------------|----------------|----------------|----------------|----------------|----------------|
| 2 | 2 | 6 | 4 | 6 | 10 | 0.1 | 0.1 |

1. A novel flow device comprising a conduit which comprises

- (1) a barrier member, and
- (2) a porous flow member (PFM) which
 - (i) comprises a solid porous material, and
 - (ii) is enclosed by the barrier member so that the PFM comprises a flowthrough section through which there can be electroosmotic and/or pressure-driven flow of a liquid;

the device having at least one of the following characteristics

- (A) the barrier member comprises a plurality of laminar barrier layers which have been laminated together around the PFM;
- (B) the PFM is a pre-shaped PFM, or, if the device comprises more than one said conduit, the PFM in at least one of said conduits, e.g. the PFM in each of said conduits, is a pre-shaped PFM;

(C) the PFM is laminar and lies in a first plane, and the device comprises a conduit which (i) is in fluidic communication with the PFM, and (ii) lies in the first plane or in a plane substantially parallel to the first plane;

(D) the PFM is laminar and lies in a first plane, and the device comprises an electrode which (i) when the device is filled with an ionic liquid, is in electrical communication with the PFM, and (ii) lies in the first plane or in a plane substantially parallel to the first plane;

(E) the device comprises at least four laminar layers, at least two of the laminar layers comprising a laminar PFM;

(F) the device comprises

- (1) a first said conduit comprising a first barrier member and a first PFM which comprises a first flowthrough section and a first transfer section, the first flowthrough section being enclosed by the first barrier member so that fluid can flow the first flowthrough section and into the first transfer section,
- (2) a second said conduit comprising a second barrier member and a second PFM which comprises a second flowthrough section and a second transfer section, the second flowthrough section being enclosed by the second barrier member so that fluid can flow through the first flowthrough section and into the second transfer section;

the first and second transfer sections

- (a) having overlapping surfaces which
 - (i) contact each other directly, or
 - (ii) are adjacent to each other and are separated from each other by a gap which optionally is filled by a porous material, and
 - (b) being enclosed by a third barrier member so that liquids flowing into the first and second transfer sections are mixed together;
- (G) the device comprises

- (1) a first said conduit in which the flowthrough section of the PFM is a first laminar PFM which lies in a first plane,
- (2) a second said conduit in which the flowthrough section of the PFM is a second laminar PFM which lies in a second plane parallel to first plane and which overlaps the flowthrough section of the first conduit;

(H1) the PFM comprises

- (a) a first layer which is composed of a first porous material,
- (b) a second layer which is in contact with the first layer along an interface and which is composed of second porous material,

the first porous material having a first pore size and second porous material having a second pore size which is larger than the first pore size, or the pore geometry of the first porous material at the interface

being such that particles above a certain pore size will not pass through the interface, and the device further comprises

(3) a fluidic inlet which communicates with the second layer but not with the first layer,

(4) a first fluidic exit which communicates with the first layer but not with the second layer, and

(5) a second fluidic exit which communicates with second layer but not with the first layer;

(H2) the PFM is composed of a porous material having an asymmetric pore size distribution such that the pore size increases, regularly or irregularly, across the thickness of the PFM, whereby the PFM has a first surface composed of relatively small pores and a second surface composed of relatively large pores, and the device further comprises

(3) a fluidic inlet which communicates with the PFM,

(4) a first fluidic exit which communicates with the first surface but not with the second surface, and

(5) a second fluidic exit which communicates with second surface but not with the first surface;

(I) the device comprises

(1) a first said conduit in which the PFM comprises a first solid porous material having a first zeta potential, the first conduit having a first inner end and first outer end,

(2) a second said conduit in which the PFM comprises a second solid porous material having a second zeta potential which is substantially different from the first zeta potential, the second conduit having a second inner end and a second outer end,

(3) an inner fluidic junction which communicates with the first and second inner ends,

(4) a first outer fluidic junction which communicates with the first outer end, and

(5) a second outer fluidic junction which communicates with the second outer end;

(J) the device comprises

(1) a first said conduit in which the flowthrough section of the PFM terminates at a first cross-sectional end surface;

(2) a second said conduit in which the flowthrough section of the PFM terminates at a second cross-sectional end surface which contacts the first surface at a butt junction; and

(3) an auxiliary porous member which contacts the sides of the first and second PFMs and bridges the butt junction;

(K) the PFM has a cross-section having a thickness of less than 4000 microns;

(L) the PFM has a cross-section having an equivalent diameter of less than 4000 microns; and

(M) the conduit is rigid.

2. A device according to claim 1 which has characteristic (A) and wherein the barrier layers have been laminated together with the aid of heat and pressure.

3. A device according to claim 1 which has characteristic (B) and which has at least one of the following characteristics

(B1) the PFM was divided from a sheet of porous material and has a rectangular cross-section;

(B2) the PFM was treated, before being contacted by any of the barrier member, to change the electrical or chemical properties of at least some of its surfaces;

(B3) the PFM includes at least one transfer section which extends from the flowthrough section by a distance of up to 4 mm;

(B4) the PFM has a constant thickness and a varying width; and

(B5) the PFM is a strip in the form of a smooth or angular spiral or zigzag.

4. A device according to claim 1 wherein the PFM comprises a liquid-impermeable tube filled with the solid porous material.

5. A device according to claim 1, which has characteristic (F) and which has at least one of the following characteristics

(F1) at least one of the first and second PFMs comprises a flowthrough section having a width w_1 and a transfer section which comprises

(i) a flared section in which the width increases to w_3 , w_3 being from 2 to 4 times w_1 , and which has a length from 0.3 to 0.7 times w_3 , and

(ii) a pre-mixing section which is adjacent to the flared section and which has the width w_3 ;

(F2) the device includes a mixing member which

(i) is composed of a porous material, and

(ii) comprises an intermediate section which lies between and contacts the first and second transfer sections, and a continuation section which extends from the first and second transfer sections;

(F3) at least one of the PFMs is divided into two parts, each part having a flowthrough section and a transfer section, and the transfer sections of the first and second PFMs are interleaved with each other;

(F4) the area A between the overlapping transfer sections has an equivalent diameter d_{transfer} such that each of the ratios d_{transfer}/t_1 and d_{transfer}/t_2 is at least 5;

(F5) liquid flows in the first transfer section along a first flow axis and liquid flows in the second transfer section along a second flow axis, and the liquid flow in the second transfer section has a component which is parallel to the first flow axis and is at least 50% of the flow.

6. A device according to claim 1 which has characteristic (G) and which has at least one of the following characteristics

(G1) the first and second laminar PFMs overlap each other in an overlap area, and one of the barrier members is an intermediate barrier member which lies between

the first and second PFMs, and which, over at least 70% of the overlap area, prevents liquid from flowing between the first PFM and second PFM.

(G2) the device comprises a junction which is in fluidic communication with the first and second PFMs;

(G3) the device comprises at least 3 laminar PFMs which lie in parallel but different planes.

7. A device according to claim 1, which has characteristic (I) and which has at least one of the following characteristics

(I1) the first and second zeta potentials have an opposite sign;

(I2) the first and second zeta potentials differ by at least 10 mV; and

(I3) the device includes

(i) a first chamber communicating with the inner fluidic junction and having a wall which comprises a flexible diaphragm, and

(ii) a second chamber having a wall which comprises the flexible diaphragm.

8. A device according to claim 1 which has characteristic (J) and in which the auxiliary member is composed of the porous material having a pore size greater than the pore size of either of the PFMs.

9. A method of causing electroosmotic flow which comprises applying an electrical potential to an ionic liquid in a flow device as claimed in claim 1.

10. A method of causing liquid flow which comprises applying pressure to a liquid in a flow device as claimed in claim 1.

11. A method of preparing a conduit which comprises

(1) a barrier member, and

(2) a porous flow member (PFM) which

(i) comprises a solid porous material, and

(ii) is enclosed by the barrier member so that the PFM comprises a flowthrough section through which there can be electroosmotic and/or pressure-driven flow of a liquid;

the method comprising placing the flowthrough section of the PFM between a plurality of barrier layers, and laminating the barrier layers together to form the barrier member.

12. A method according to claim 11 wherein the lamination is carried out with the aid of heat and pressure.

13. A method according to claim 11 wherein at least one of a fluid conduit and an electrode is placed between the barrier layers before the barrier layers are laminated together.

14. A method of preparing a conduit which comprises

(1) a barrier member, and

(2) a porous flow member (PFM) which

(i) comprises a solid porous material, and

(ii) is enclosed by the barrier member so that the PFM comprises a flowthrough section through which there can be electroosmotic and/or pressure-driven flow of a liquid;

the method comprising placing the flowthrough section of the PFM in a mold, placing a hardenable liquid composition in the mold around the PFM, and hardening the composition to encapsulate the flowthrough section.

* * * * *