

April 18, 1950

A. H. DOWNS

2,504,117

METHOD OF SPRAYING MULTICOLORED COATINGS

Filed Aug. 24, 1945

5 Sheets-Sheet 1

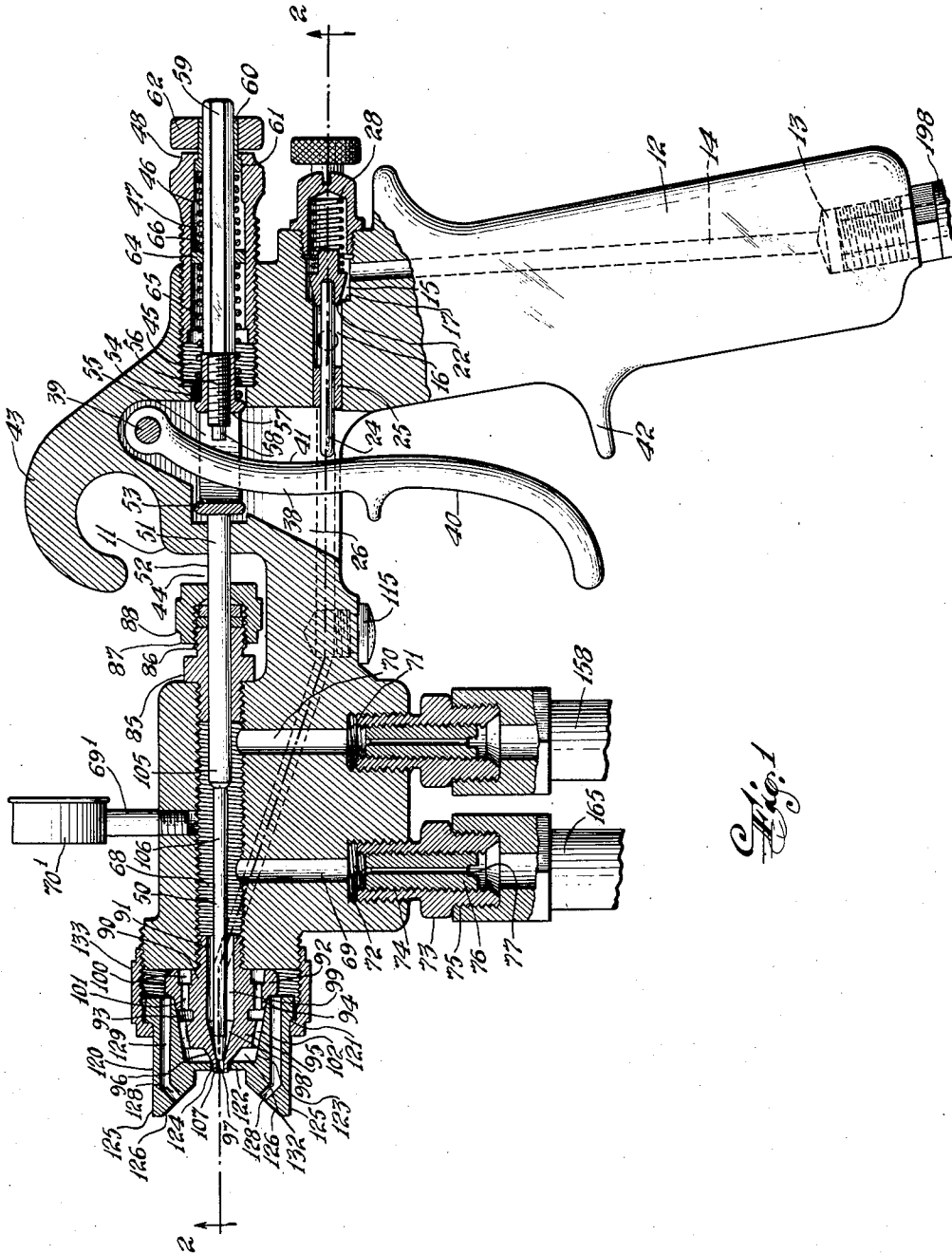

Fig. 1

INVENTOR.  
*Austlin H. Downs*  
BY  
*Angelo W. Picano*  
ATTORNEY.

April 18, 1950

A. H. DOWNS

2,504,117

METHOD OF SPRAYING MULTICOLORED COATINGS

Filed Aug. 24, 1945

5 Sheets-Sheet 2

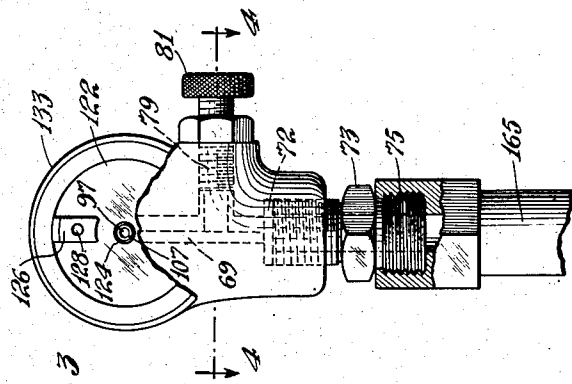
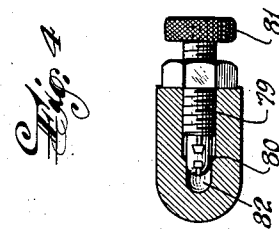
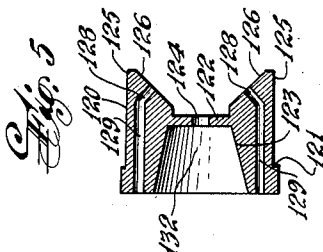
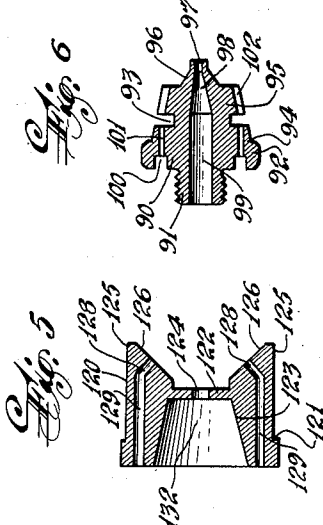
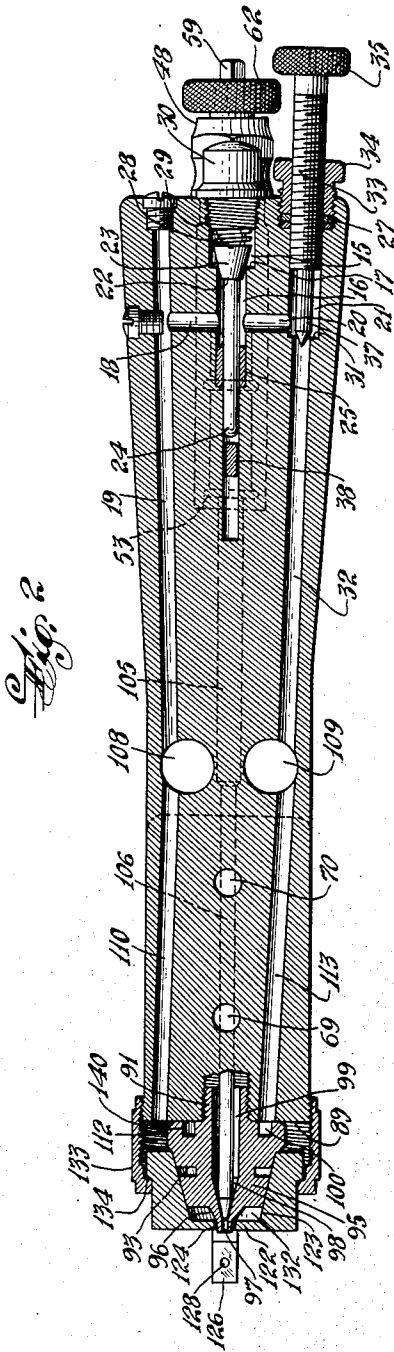

INVENTOR.  
*Austin H. Downs*  
 BY  
*Angelo M. Pisana*  
 ATTORNEY

April 18, 1950

A. H. DOWNS

2,504,117

METHOD OF SPRAYING MULTICOLORED COATINGS

Filed Aug. 24, 1945

5 Sheets-Sheet 3

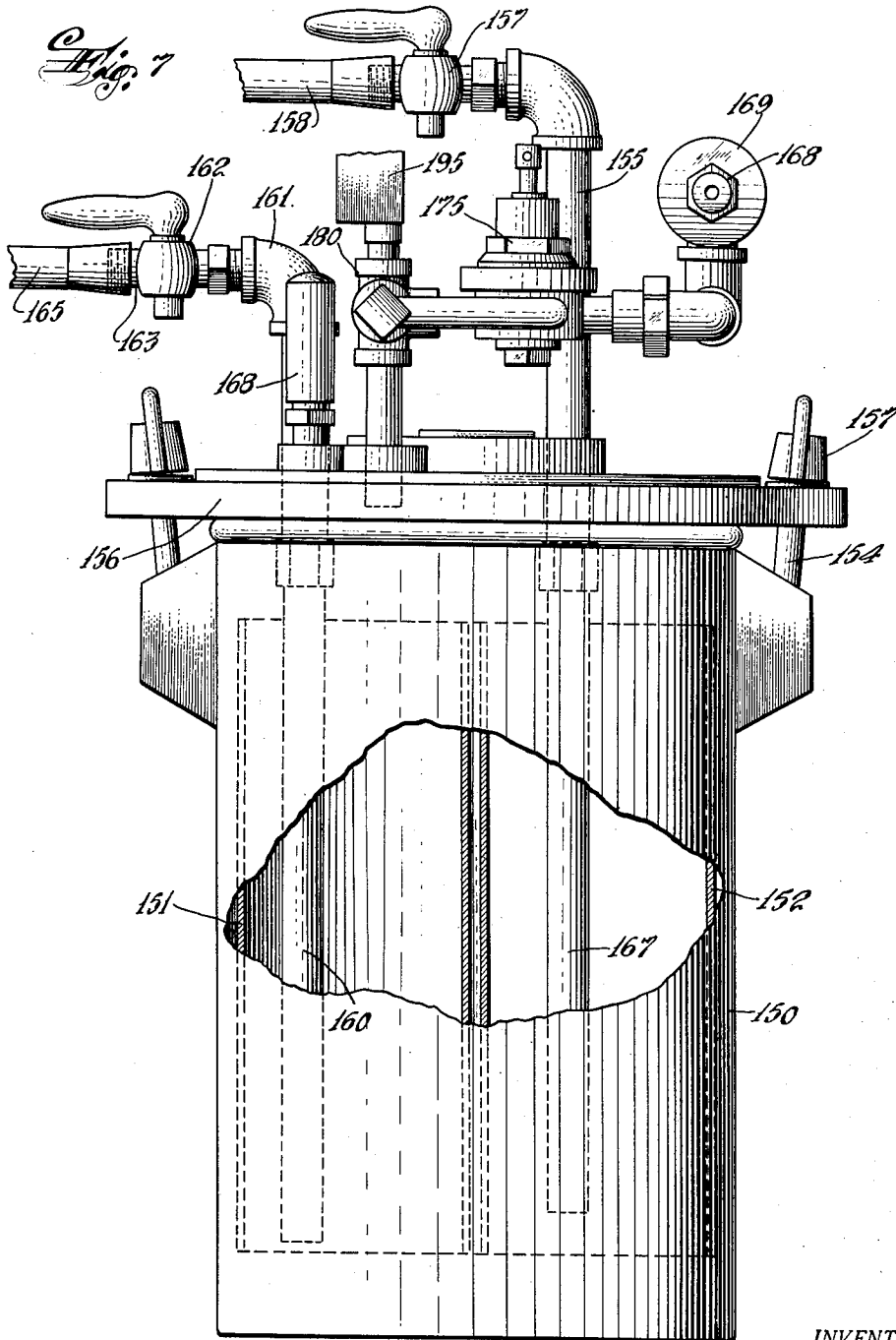

INVENTOR.

*Austin H. Downs*

BY

*Angelo M. Pizarra*

ATTORNEY

April 18, 1950

A. H. DOWNS

2,504,117

METHOD OF SPRAYING MULTICOLORED COATINGS

Filed Aug. 24, 1945

5 Sheets-Sheet 4

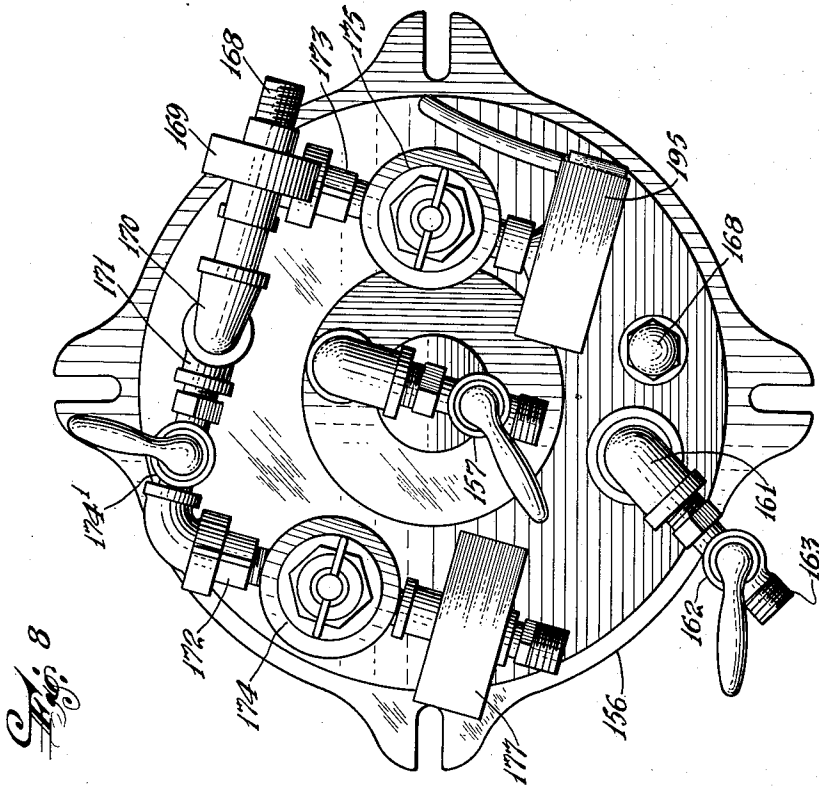

INVENTOR.  
*Austin H. Downs*  
BY  
*Angelo W. Picerno*  
ATTORNEY

April 18, 1950

A. H. DOWNS

2,504,117

METHOD OF SPRAYING MULTICOLORED COATINGS

Filed Aug. 24, 1945

5 Sheets-Sheet 5

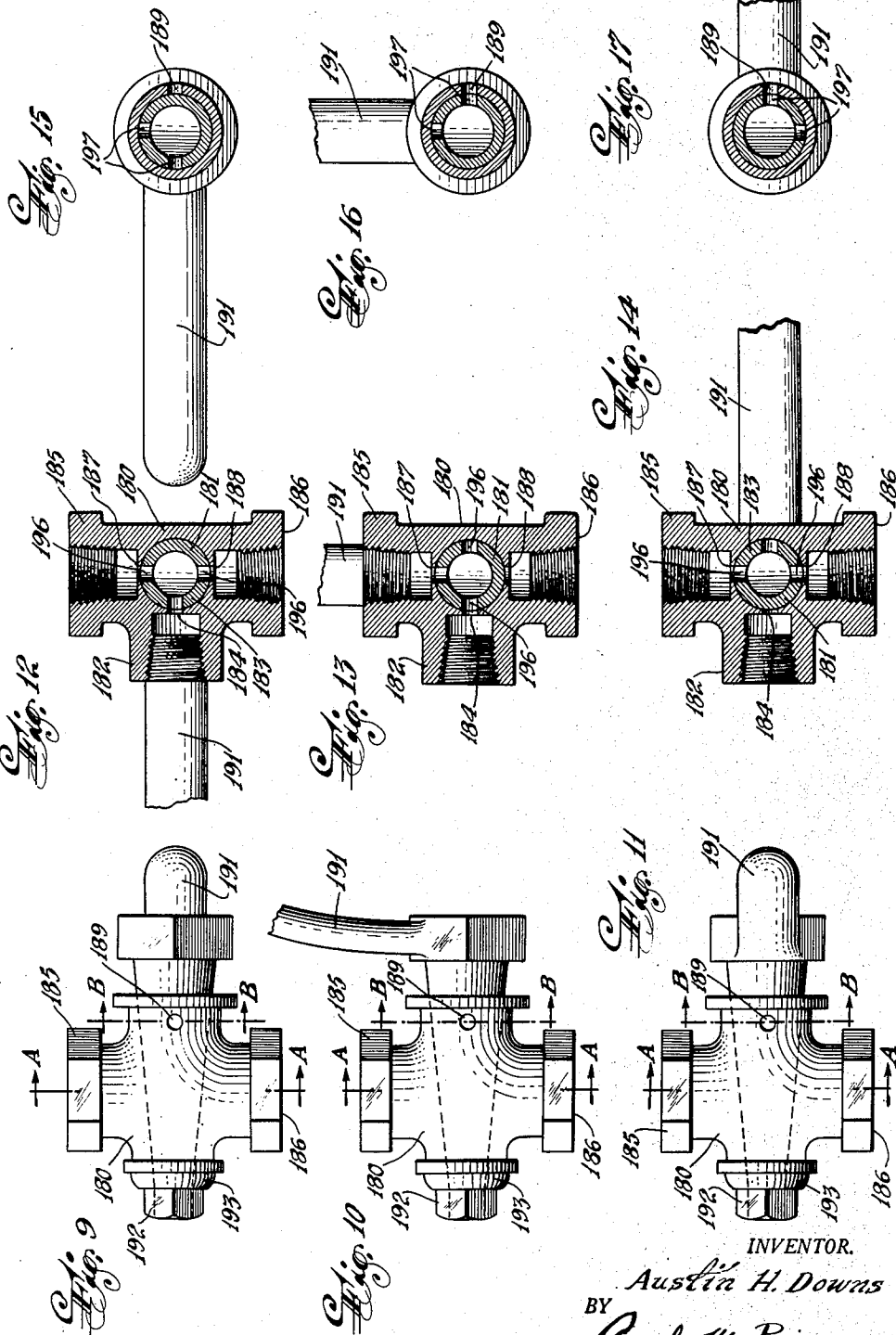

INVENTOR.  
*Austin H. Downs*  
BY *Angelo M. Pisana*  
ATTORNEY

# UNITED STATES PATENT OFFICE

2,504,117

## METHOD OF SPRAYING MULTICOLORED COATINGS

Austin H. Downs, Glen Ridge, N. J., assignor to  
Eclipse Air Brush Co., Newark, N. J., a corpora-  
tion of New Jersey

Application August 24, 1945, Serial No. 612,351

4 Claims. (Cl. 117—104)

1

This invention relates to novel methods and apparatus for coating a surface of an object. More particularly, this invention is directed to novel methods and apparatus for providing attractive coatings of substantially constant pattern or design by a single spraying operation. In one of its more specific aspects, the invention is directed to novel methods for providing with the same apparatus a wide variety of multi-colored designs or patterns without the necessity of more than one spraying operation for each particular pattern. By employing my novel method and apparatus, there is provided a practical method for spray application in the field to obtain uniform spattered surface coatings capable of being indefinitely reproduced. Further, by employing the novel methods and apparatus, there may be obtained a wide range of color effects using the same materials and in a single spraying operation for each individual effect. In addition, all of these advantages may be obtained without sacrificing speed of spraying. According to this invention, a plurality of different coating media, preferably in liquid form, such as paints or the like are fed into a common fluid receiving chamber terminating in a discharge orifice. These coating media may differ in color and/or viscosity. Said liquids are fed into said chamber at different places and preferably along the length or longitudinal axis of said chamber which is preferably elongated. In the preferred form of this invention, said liquids are fed into said chamber through openings in said chamber which openings are spaced from each other. These liquids are preferably fed through said openings to said chamber as streams or free columns. By having the viscosity and color of the liquid of one of said streams or columns different from the correspondent characteristics of the liquid of another of said columns, I may obtain a two-tone effect; and by having the viscosity of these two liquids the same and having their colors different, I may obtain a three-tone effect because in this case due to the viscosity being substantially the same, there is more blending, which blend forms the background, and the spatter thereon is a two-color combination on blended background. The inlet or place of entry of said columns of paint into said receiving chamber are preferably spaced from each other and said columns as they enter said chamber are disposed at an appreciable angle and preferably at approximately right angles to the longitudinal axis of the receiving chamber. When liquids of different viscosities are employed, I prefer that the liquid of greater viscosity be fed to said chamber at the opening closer to the orifice thereof than the place of entry of said liquid of lower viscosity. By so controlling the position of entry of these liquids of different viscosities, I am able to obtain a substantially uniform pattern on the

2

object being coated. By employing this method, the higher viscosity or higher specific gravity coating medium travels in greater part along the normally lower longitudinal portion of said chamber in the course of its motion towards the discharge orifice. The lesser viscosity or specific gravity paint in the course of its travel through the chamber to the discharge orifice "floats" on the higher viscosity liquid and together with the higher viscosity or specific gravity material discharge as a single unitary composite stream through the free end of the orifice where it is acted upon by an annular or somewhat conical stream of air under pressure which breaks up said unitary stream into small particles which are deposited upon the surface to be coated. Besides atomizing said unitary stream into small particles, said air or other gaseous medium under pressure mixes said particles of discharge prior to their reaching the surface to be coated. The shape of this spray may be controlled by a pair of opposite streams of air projected towards each other and into the spray or atomized discharge.

By practicing my novel methods, I have obtained unusual and unique multicolored surface coatings by employing a single spraying operation which coatings are capable of being applied at field spraying speed and are capable of being continuously reproduced. One of the outstanding characteristics of this invention is that by employing the invention multicolored coatings simulating hammered, pebbled, webbed, stipple or other type surfaces may be obtained by employing a single spraying operation.

An object of this invention is to provide a novel method for simultaneously spraying a mixture of atomized liquids on to a surface.

Another object of this invention is to provide a novel method for simultaneously spraying a mixture of different colored coating media on to the surface of an object to be coated.

Another object of this invention is to provide a novel spraying device.

Another object of this invention is to provide a novel spraying device for simultaneously spraying a mixture of different colored coating media on to the surface of an object to be coated.

Another object of this invention is to provide a novel system or apparatus for spraying materials.

Another object of this invention is to provide a novel system or apparatus for simultaneously spraying a mixture of different colored paints on to the surface of an object to be coated.

These and other objects of this invention will be readily apparent from the following description and accompanying drawings, wherein;

Figure 1 represents a vertical longitudinal cross sectional view of a spraying device embodying the invention.

Figure 2 is a horizontal longitudinal cross sec-

3  
tional view taken along line II—II of Figure 1 in the direction of the arrows.

Figure 3 is a view in front elevation of the upper part of the spraying device shown in Figures 1 and 2, but with the pressure gage not shown.

Figure 4 is a cross sectional view taken on line IV—IV of Figure 3 and in the direction of the arrows.

Figure 5 is a cross sectional view of the nozzle shown in Figures 1 and 2.

Figure 6 is a cross sectional view of the fluid tip shown in Figures 1 and 2.

Figure 7 is a view in side elevation of a supply system adapted to be connected to the spraying device shown in Figures 1 and 2.

Figure 8 is a top plan view of apparatus shown in Figure 7.

Figures 9, 10 and 11 are plan views of housing and valve in three different positions.

Figures 12, 13 and 14 are cross sectional views taken on line A—A of Figures 9, 10 and 11 respectively.

Figures 15, 16 and 17 are cross sectional views taken on lines B—B of Figures 9, 10 and 11 respectively.

Referring to the drawings the numeral 10 designates the body of a paint spraying device illustrating an embodiment of the invention. The body 10 includes a barrel portion 11 and a handle portion 12. The handle portion 12 extends downwardly from the barrel portion 11 and is inclined slightly to the rear thereof so that the body 10 has somewhat the appearance of an automatic revolver.

The lower end of the handle portion 12 has an internally threaded opening 13 therein. The opening 13 communicates with a passage 14 which extends upwardly through the interior of the handle 12 to an air inlet valve chamber 15 in the rear part of the barrel portion of body 10. The chamber 15 communicates with an air distributing chamber 16 disposed forwardly thereof in barrel portion 11. The chamber 16 is of smaller diameter than the chamber 15 and the shoulder at the end of the chamber 15 as it meets chamber 16 acts as a valve seat 17. A passageway 18 communicates with and extends from chamber 16 directly to a passageway 19 extending along the barrel portion 11 from its rear towards the nozzle end of the device. Another passageway 20 communicates with and extends from chamber 16 directly to a valve chamber 21.

Mounted in the valve chamber 15 is a suitable valve member 22 having a valve proper 23 adapted to engage the valve seat 17 and having an operating rod or stem 24 integral therewith and extending forwardly therefrom. The valve stem 24 extends through a suitable bearing opening 25 in the barrel portion and into an open inverted approximately V shaped slot 26 in said barrel portion. The rear end of the valve member 23 is provided with a stud or projection 27 receiving one end of a coiled compression spring 28. The other end of said spring 28 is positioned in an exteriorly threaded socket 29 integral with and disposed at the forward end of a securing and tensioning adjusting nut 30 secured to the interiorly threaded rear end of the valve chamber 15. By this means the valve proper 23 is normally held in tight engagement with the valve seat 17 so that if air under pressure is admitted to the chamber 15 through the communicating passageways 13 and 14, no air under pressure is admitted through the passages 16, 18, 19, 20 and 21.

4  
The degree of force of the valve 22 in the direction of the valve seat 17 is controlled by the compression spring 28 which in turn is controlled by the nut 30.

5 The valve chamber 20 is provided with a valve seat 31 and communicates with and leads into a passageway 32 extending in the same direction as passageway 19 along the barrel interior and towards the nozzle end of the device. A needle valve 33 is mounted in the valve chamber 20 through an internally threaded portion of a mounting nut 34. The outer end of the valve 33 terminates in a knurled manipulating knob 35 by which the inner or valve end 37 may be adjusted relative to the valve seat 31 to regulate the flow of air into passage 32 as desired or to cut it off completely if required.

A trigger 38 has its upper end located at the apex of the slot 26 and is pivotally connected at its upper end to the barrel portion 11 by a pivot pin or bolt 39. The trigger 38 extends below the slot 26 and its downwardly extending lower portion 40 is curved to provide a hand saddle so it may be readily and positively engaged by certain fingers of the hand of an operator. The rear face of that portion of the trigger 38 in the slot 26 has a rear bearing face 41 engaging the free front end of the valve stem 24. When the trigger 38 is swung rearwardly about the pivot 39, the valve stem 24 and valve proper 23 are forced rearwardly against the action of the spring 28 whereupon the valve 23 is moved away from the valve seat 17 to permit the admission of air under pressure from the chamber 15 into passageways 16, 18, 19, 20 and 21 and if the needle valve 33 is in open position, into passage 32.

The rearward movement of the trigger 38 is limited by means of the abutment of the lower portion 40 thereof against the external face of the handle portion 12. Spring 28 is of sufficient strength normally to hold the valve 22 in closed position and the trigger in its fully extended open position shown in full lines in Figure 1 and to cause these parts to assume these positions when the external pressure on the trigger is sufficiently reduced. Thus a very simple and delicate control is provided for controlling the admission of air into the device and it is very easily regulated by an operator without the necessity of long training and experience. For additional ease of manipulation and to insure a firm grip, the handle portion 12 is provided with a finger lug or guard 42 projecting from said handle portion 12 directly below and adjacent the lower end of the trigger.

55 The barrel portion 11, when the gun is held in a normal position, extends in a horizontal direction forwardly from the handle portion 12 and is provided with a curved lug or hook 43 to provide a convenient hanging means for the device when not in use. On its upper part and in the vicinity of the midlength of the barrel portion, there is provided a cut out portion 44. The barrel portion 11 is bored centrally at its rear to provide a valve operating chamber 45 interconnecting with the slot 26 in barrel 11. Chamber 45 is internally threaded and has threadedly coupled thereto a hollow elongated nut 46 screwing through the rear end thereof. The nut 46 has a spring chamber 47 and a central opening 48 at its rear end and axially aligned therewith.

A valve rod 50, for controlling the supply of liquid material, extends into the valve operating chamber 45 through its front end and is movably mounted within a forward bearing part 51 of the central barrel bore. Inside said cham-

ber 45 said rod 50 is enlarged in diameter at 52 and is provided with two spaced shoulders 53 and 54. A vertical slot 55 is provided in the rod 50 between shoulder 53 and 54 and the upper portion of trigger 38 passes therethrough and is movable therein. The rear end of rod 50 is provided with an internally threaded bore 56 extending from said end through the rear end of slot 55. Threadedly engaged in said bore 56 is an operating rod 57 having a forward nose 58 projecting into said slot 55 and is adapted to be engaged by the trigger 38 when said trigger is moved rearwardly to operative position as hereinbefore described. Operating rod 57 may be of hexagonal or other polygon shape in section as at 59. A riveting collar 60 is slidably borne to the rear end of rod 50. This collar 60 has a flange 61 which engages the inner shoulder at the rear end of the nut 46. A rotatable knob 62 is fixedly mounted on collar 60 so that rotation of knob 62 will rotate collar 60 and in turn the rod 57.

Intermediate its ends rod 57 is provided with a slide ring 64. A coil spring 65 is mounted around the front part of rod 57, with one end of said spring abutting against shoulder 54 and its other end against one face of ring 64. A coiled spring 66 is mounted around the rear part of rod 57, with one end engaging the opposite face of the ring 64 and its other end abutting against the flange 61. These springs 65 and 66 normally urge the rod 57 and consequently valve rod 50 forwardly.

The adjustable positioning of the nose 58 through the knob 61 by the parts above described so that it is nearer to or further away from the trigger 38 permits a fine variation of the relative movement of the valve rod 50 when the trigger is actuated, as well as a fine control of the relative time of opening of the air valve 23 and the fluid outlet valve when the trigger is moved. The time may be thus controlled to effect simultaneous operation of the air and fluid outlet valves or later opening of the fluid outlet valve with respect to the air valve 23. In Figure 1, the position of the nose 58 is such that the trigger 39 will first engage the stem 24 to first open valve 23 and then engages nose 58 to actuate valve rod 50.

The forward end of the barrel portion 11 is provided with an internally smooth or threaded longitudinal bore forming a liquid receiving chamber 68. The lower part of the barrel portion 11 is enlarged at its underside to provide an extension 69 having a plurality of, and as shown merely for the purposes of illustration two, supply passageways 69 and 70 communicating with the supply chamber 68. These passageways 69 and 70 may be of the same or if different lengths and diameters and as illustratively shown are of the same dimensions. Each of said passageways is preferably disposed roughly at right angles to the chamber 68 and depends therefrom. The passageways 69 and 70 are preferably one behind the other in single file relationship and are roughly parallel to each other and are located in about the same plane. The passageways 69 and 70 may be cylindrical and terminate at their lower ends in respectively enlarged internally threaded coupling bores 71 and 72 whose diameters are the same and materially greater than the diameter of passageways 69 and 70.

Demountably mounted in each coupling bore 71 is a double nipple 73 having each of its ends 74 and 75 threaded. The hollow nipple 73 is internally threaded and has demountably mounted therein, an exteriorly threaded cylinder 76 hav-

ing a central cylindrical bore or passageway 77. The dimensions of the bore or passageway 77 are preferably such that the length thereof is many times the diameter. In one of the preferred embodiments of the invention the length of passageway 77 is at least 5 times the diameter thereof. The diameter of the passageway 77 is much less than the diameter of passageways 69 and 70 and the length and diameter of the passageways 69 and 70 and the passageway 77 are so chosen that the fluid under pressure discharges substantially as a column from the passageway 77 through passageway 69 or 70 and into chamber 68 without to any great extent striking the sides of the passageway 69 or 70. While the passageways 77 may be of the same diameter, I prefer to employ cylinders 76 having passageways 77 of different diameters. Instead of employing the cylinders 76 in the demountable nipples 73, a lateral threaded opening 79 communicating with the opening 69 or 70 may be provided in the barrel portion 11 and in each of said openings 79 there may be provided a valve 80. The valve 80 extends into the passageway 69 or 70 and may be actuated by knob 81 to vary the opening 82 between passage 69 or 70 and valve 80 to control the flow of material through the supply openings and into the chamber 68. These adjustable valves 80 may be associated with both of the openings 69 or 70 and are independently operable to vary the flow in either or both of said openings 69 or 70.

Extending through the upper part of the barrel 11 is an opening accommodating a nipple 69' connected to a pressure gage 70'. The longitudinal center line is parallel to the longitudinal center lines of the passageways 69 and 70 and all three center lines are in the same plane. The nipple 69' is located approximately midway between the passageways 69 and 70 and the dial of the gage 70' faces towards the hook 43.

Receiving chamber 68 is in axial alignment with valve operating chamber 45 and valve rod 50 projects into said chamber and is slidably movable toward and away from the front end of the chamber 68, is slidably borne and guided in a packing nut 85 screwed to the rear of said chamber 68. The rearwardly extending portion 86 of nut 85 is externally threaded and a hollow clamping nut 87 is screwed thereon and serves to force and clamp packing material 88 tightly about the valve rod 50 and seal the rear end of said receiving chamber 68 against leakage while permitting sliding movement of the said rod. The front end of chamber 68 is internally screw-threaded and terminates in the flat front face 89 of the barrel 11, and a fluid tip 90 is adapted to be received in said screw threaded chamber 68.

This fluid tip 90 is provided with a screw-threaded extension 91, whereby it is secured in position engaging the forward screw thread of the receiving chamber 68. It has a hexagonally or polygonally shaped flange 92 directly adjacent the extension 91 and a conical portion having a circular recess or slot 93 to provide a pair of frustro-conical portions 94 and 95, with the greatest diameter of portion 94 being equal to the perpendicular distance between the faces of flange 92. The forward end of tip 90 is a short conical section 96 terminating in a small diameter cylindrical nose. The forward end of conical opening 99 acts as a valve seat for the free forward end of valve rod 50. The nose has a small diameter opening 97 therein communicating with a conical opening 98 in cone 96 which in turn communicates with a cylindrical opening 99 whose diam-

eter is equal to that of the base of cone opening 98.

The flange 92 has a shallow cylindrical recess 100 therein at about the midthickness thereof. Equally spaced small cylindrical openings 101 parallel to the opening 99 extend through the portion 94 to provide communicating passageways between the opening 100 and opening 93. The portion 95 has a plurality of slots 102 throughout the entire length thereof. These slots 102 are of uniform depth and length, with each slot located on the hypotenuse. The lower ends of the slots 102 terminate near the ends of the openings 101.

The plunger or front portion of the valve rod 50 is in the form roughly of an elongated needle or rod having a rear portion 105 extending from the shoulder 53, through opening 51, nut 81, packing 83 and nut 85 and into chamber 68, and a front portion 106 of smaller diameter than rear portion 105 and terminating in a conical or valve tip 107. When the valve tip 107 seats in the conical opening 98 and is normally in this position when the trigger is not actuated by any outside force, the fluid receiving chamber is sealed to prevent the passage of fluid out of the orifice 97. When said valve 107 is opened by pressure on the trigger as before described, fluid passes from the chamber 68 and out through the forward end of the orifice 97 in the nose.

The air passages 19 and 32 extend horizontally along the barrel toward its forward end, to the respective chambers 108 and 109 (Fig. 2) and converge slightly in their approach thereto. A passageway 110 extends upwardly and outwardly in the barrel 11 from the chamber 108 and terminates in the flat front face 112 of said barrel directly adjacent and outside of the flange 92.

A passageway 113 leads upwardly and outwardly in the barrel 11 from the chamber 109 and also terminates in the front flat face 112 of said barrel at a diametrically opposite point to terminus of said passageway 110. The passageway 113 communicates with the recess 100. The chambers 108 and 109 are provided to facilitate the boring of the respective passageways 110 and 113 and each is suitably sealed at its lower end by the respective sealing plugs 115 and 116. In this manner, two continuous air passages from the air distributing chamber 16 to the tip or forward end of the barrel are provided, one of which is independently valve controlled through the valve 33 whereby air through passageways 32, 109 and 113 may be adjustably restricted or cut off entirely as desired.

A nozzle 120 may be applied over the fluid tip 90 and is preferably of the external or outside mix type. The nozzle 120 is of generally cylindrical external contour and has a lower portion of enlarged diameter to provide a retaining shoulder 121. The nozzle 120 has a front closure 122 and is hollow to provide a generally conical internal face 123. The closure 122 has a central circular opening 124 therethrough and the diameter of this opening is somewhat larger than the external diameter of the nose of fluid tip 90, which nose extends through opening 124 and slightly forward of the front face of closure 122 to provide an annular opening between the tip nose and the circular opening 124. The nozzle 120 also includes a pair of air jet outlet members 125 integral with closure 123 and longitudinally extending therefrom. These members 125 are diametrically arranged at opposite sides of the opening 124.

The upper parts of the facing sides 126 of mem-

bers 125 slant upwardly outwardly away from each other. Each of said members is provided with a passage outlet 128 disposed at about right angles to the face 126 and communicating with an opening 129 which extends from opening 128 and extends through the lower or inner face of the nozzle 120. The nozzle 120 is mounted on the fluid tip 90 as shown in Figures 1 and 2, with the inner edge of the lower part of nozzle 120 abutting against the inner edge of flange 92. The lower face of nozzle 120 extends outwardly beyond flange 92 leaving exposed the lower end of passageways 129. The entire outermost conical faces of portions 94 and 95 of fluid tip 9 snugly abut against the lower internal conical face 123. The nose of the fluid tip 90 extends through the opening 124 and its outer extremity is located beyond the front face of closure 122. Between the inner face of closure 122 and the upper end of the conical portion 95 is an air chamber 132. A threaded collar or clamping nut 133 is threadedly connected to the front end of barrel 11 and has a flange 134 abutting against shoulder 121 to demountably lock the fluid tip 90 in position. The desired angular position of the members 125 may be varied by merely loosening the nut 133 and rotating the nozzle the proper amount.

Air under pressure passes out of passageway 113, into annular recess 100 and then through the equally spaced openings 101. From the openings 101, the air travels through into annular recess 93, through the slots 102, into the chamber 132, through the portion of the passage 124 around the circumference of the projecting nose of fluid tip 90.

The air as it passes beyond the front face of the closure 122 sets up an eddy current effect at the discharge terminus of said nose of tip 90. These eddy current effects serve to atomize and mix the fluid as it passes out of said nose and towards the surface to be coated.

Air under pressure from the passageway 110 enters the chamber 140, whose one side is formed by the lock nut 133, then passes through the passageways 129, then through 128 and project towards each other to further mix and control the shape and dimensions of the spray as it leaves the nozzle 120.

A compact and relatively simple novel unit may be coupled with the aforesaid spray device for my purposes. As shown in Figures 7 and 8 it may comprise a cylindrical pressure tank 150 having located therein a pair of removable semi-cylindrical paint carrying tanks 151 and 152. Pivotaly secured to the upper end of said tank 150 are a plurality of hinged bolts 154 adapted to be demountably coupled to slotted ears 155 extending outwardly from a tank top 156. The top is removably secured to said tank by wing nuts 157 on said bolts. Said top 156 has a pair of diametrically disposed openings therethrough and mounted in one of said openings is a hollow pipe 160 depending therefrom and into tank 151 and below the upper level of paint therein. Also mounted in said opening and communicating with pipe 160 is a conduit 161 having an ordinary two-way valve 162 coupled thereto.

The valve 162 is coupled to a nipple 163 in turn coupled with the nipple 73 for passage 69 by means of a flexible hose or other type of conduit 165. A pipe 167 is mounted in said other opening in the top 156 and depends from said top and into the tank 152 with its lower end located below the upper level of the paint contained therein. A conduit 155 having an ordinary two way valve

157 therein is in communication with pipe 167 and by flexible hose 158 is connected to the passageway 70.

A safety pressure valve 168 is mounted in an opening extending through the top 156 and is supported thereby. An air inlet 168 is connected to a source (not shown) of air under pressure. The air inlet 168 is connected to an air filter 169 connected to a conduit 170 connected to a cross conduit 171 having its ends connected to conduits 172 and 173 having respective reducing or regulating valves 174 and 175 therein. The conduit 172 has a pressure gage 177 connected thereto on the outlet side of valve 174. The conduit 173 is connected to the T housing 180 having a hollow chamber valve 181 therein. The housing 180 has the stem inlet 182 thereof communicating with a central conical portion or valve seat 183 having a slot 184 therein communicating with inlet 182. Outlets 185 and 186 are at right angles to said inlet 182 and are in the same straight line. The portion 184 has slots 187 and 188 communicating with respect to outlets 185 and 186. The central conical portion has a small opening 189 extending through a side thereof. The conical valve 181 has an actuating handle 191 located in the conical portion 183 and is secured to housing 180 by a nut 192 and washer 193 arrangement secured to a projecting thread portion of the valve 190 extending outside of said housing.

The conduit 173 is connected to the stem inlet 182, the upper outlet 183 is connected to a pressure gage 195 and the lower outlet 184 is connected to the tank 150. The valve 181 has three slot openings 196 and a pair of circular openings 197 therein. When the handle 191 is in the position shown in Figure 12, the three slot openings 196 are in registry with the openings 184, 187 and 188 so that the air under pressure passes to the pressure gage 195 and to the tank 150. The pressure within the tank 150 may be regulated by actuating the handle of the regulating valve 175. When the pressure of the liquid in the tanks 151 and 152 is properly adjusted as indicated by the gage and the handle 191 is in the position shown in Figure 12, the valves 156 and 162 are opened so that the liquids in tanks 151 and 152 flow up through the respective conduits 158 and 165, through the respective passageways 69 and 70 to the fluid receiving chamber 68. The cross arm conduit 171 has a two way valve at the inlet side of regulating valve 174 and when this valve is open the air under pressure is regulated by the valve 174 to the proper pressure as shown by gage 177 and is conducted to the passageway 14 by a hose 198 connected to the enlargement 13 at the lower end of handle 13 and to the discharge side of valve 177. With the handle in the position shown in Figure 13, the slot 188 is blocked, only the slots 184 and 187 are in registry with two of slots 196 and one of the openings 197 is in registry with one of the openings 197. With the handle in the position shown in Figure 14, the slot 184 is blocked so no air under pressure reaches either the gage 195 or the tank and an opening 197 is in registry with opening 189 so that air in the tank can escape.

In operation, after the pressure in the tank has been properly adjusted and pressure in the air supply line to the spraying device has been properly adjusted, and the spraying device has been connected to said air supply line and to the fluid supply lines from said tank, the operator is ready to spray coat. In the practice of this invention, it is preferable to employ paints

of different viscosities in the tanks 151 and 152 and I prefer that the higher viscosity paint be in tank 151 connected to the passageway 69. Since both paints are located in separate tanks 151 and 152, they are both at the same pressure since they are in the same pressure tank. The paint from tank 151 is conveyed under pressure through piping 160, 161, valve 162, hose 165, front passageway 77 from which it discharges as a free column through the passageway 69 and into the chamber 68. The paint from the tank 152 is conveyed under pressure through piping 167, 155, valve 156, hose 158, rear passageway 77 from which it discharges as a free column through passageway 77 and into chamber 68. The air under pressure is conveyed through hose 198 to the passageway 13 into chamber 15. With the valve 33 set in the open position shown in Figure 2, the spraying device is ready for operation. It is to be understood that if desired the valve 30 may be completely eliminated if desired and are employed only if adjustable means for regulating the flow of fluids in passageways 69 and 70 are desired. The chamber as shown has an internal diameter of about .375" and the diameters of the openings 77 may vary preferably between about .025" and .10" and are at least .5" long, and the inserts 76 are preferably located as close to the receiving chamber 68 as is practical.

The operator forces the trigger 38 towards the handle 13. The trigger 38 first strikes the rod 24 to unseat valve 23 whereupon the air passes into chamber 16, through passages 18, 19, 108, 110 into chamber 140 and through passages 129 and 128; and also from chamber 16 through passages 20, chamber 33, passages, 32, 109, 113, slot 100, openings 101, slots 93, 102, chamber 132 and then between the outside of the nose of fluid tip 90 and the orifice 124.

While the air continues following the aforementioned path, the trigger strikes the nose 58 and retracts the valve rod 50 to open the fluid or paint discharge orifice 97 at the end of the common paint receiving chamber formed by the aligned chamber 68, and the chamber in said fluid tip 90. The different colored paints discharge out of said orifice 97 and are atomized and mixed by the eddy currents created by the discharge of air through orifice 124 and as the atomized paint mixture in its course of travel towards the surface to be painted passes between the air jets from openings 128, it is further mixed and the configuration of the spray is modified. When the trigger 38 is released, the orifice 97 is first closed by the valve rod 50 and then the valve 15 assumes its closed position.

With the trigger 38 in its rearmost or operative position, the liquids which enter the chamber 68 and pass out of the discharge orifice thereof are in contact with each other in said chamber for such a very short period of time that they discharge out of said chamber before they become blended into a homogeneous blend. Thus it does not matter in the practice of this invention whether the liquids are miscible, or immiscible. It may be practiced with either of these two types of materials. When the liquids are immiscible very little, if any, blending occurs. When they are highly miscible and easily blendable, liquids are employed, a certain proportion of these liquids blend together. And, it is by virtue of this that a three colored spattered surface may be obtained by using but two different colored liquids.

In the practice of this invention; the pressure on the liquids in the tank is preferably maintained in the range of about 15 to 50 pounds per square inch and more preferably in the range of 18 to 32 pounds per square inch while the air pressure reading at gage 177 is preferably maintained in the range of 20 to 50 pounds per square inch and more preferably in the range between 34 and 46 pounds per square inch. The needle valve 50 may be adjusted to any desired setting and after the setting is made, the operator obtains the particular pattern that he desires, noting the air pressure at gage 177, the fluid tank pressure at gage 70' with the trigger in inoperative position and the pressure at gage 70' with the trigger swung to its rearmost position. In order to duplicate the same pattern in the field all he need do is to use the same constituents or paints in the respective tanks and employ the particular air and tank pressures and adjust the valve 50 until the pressure on gage 70' during discharge corresponds to that in making the original pattern. For example, it has been found that an attractive pattern may be produced by employing paints of different colors and viscosities with the paint of heavy viscosity fed to the chamber through conduit 165 and lighter viscosity paint through conduit 153. The fluid tank pressure was maintained in the range of about 22 to 28 pounds per square inch and the air pressure was maintained at about 35 to 45 pounds per square inch and the valve 50 was so adjusted that the pressure gage reading when the trigger was in its rearmost position was about 2 to 8 pounds per square inch. Of course, with my apparatus it is feasible even in the field to maintain any of these pressure readings within  $\pm 1$  and by so maintaining them the patterns may be reproduced in detail. By following the above procedure the ratio of the rate of discharge through the discharge orifice of the lower viscosity liquids to that of the higher viscosity material is maintained between 1.5 to 1 and 3 to 1 and preferably between 2 to 1 and 2.5 to 1.

The foregoing system and spray device may be employed by even an unskilled workman and may be employed to carry out my novel methods for obtaining unique spray coatings of different colors. Although the invention has been described in detail, it is not to be limited thereby because many changes and modifications may be made without departing therefrom.

This application is a continuation in part of my co-pending application Serial No. 557,955 and filed October 10, 1944.

I claim:

1. The method of spraying a surface comprising feeding a plurality of differently colored liquids into a common fluid receiving chamber having a discharge orifice, discharging said liquids in a unitary stream from said chamber before said liquids are homogeneously blended, said liquids being fed separately through openings located one entirely behind the other with respect to said orifice and along the length of said chamber, applying gas under pressure to said stream in the substantially immediate vicinity of said orifice to convert said stream into a spray, subjecting said spray to gas under pressure to modify the shape of said spray and then depositing said spray onto a surface to be coated.

2. The method of spraying a surface comprising feeding a plurality of differently colored liquids of substantially the same viscosity into a common fluid receiving chamber having a discharge orifice, discharging said liquids in a unitary stream from said chamber before said liquids are homogeneously blended, said liquids being fed separately through openings located one entirely behind the other with respect to said orifice and along the length of said chamber, applying gas under pressure to said stream in the substantially immediate vicinity of said orifice to convert said stream into a spray, subjecting said spray to gas under pressure to modify the shape of said spray and then depositing said spray onto a surface to be coated.

3. The method of spraying a surface comprising feeding a plurality of differently colored liquids of substantially different viscosities into a common fluid receiving chamber having a discharge orifice, discharging said liquids in a unitary stream from said chamber before said liquids are homogeneously blended, said liquids being fed separately through openings located one entirely behind the other with respect to said orifice and along the length of said chamber, said liquid of greater viscosity being fed into said chamber through said opening located closer to said orifice than another of said openings through which said liquid of lower viscosity is fed, applying gas under pressure to said stream in the substantially immediate vicinity of said orifice to convert said stream into a spray, subjecting said spray to gas under pressure to modify the shape of said spray and then depositing said spray onto a surface to be coated.

4. The method of spraying a surface comprising feeding a plurality of differently colored liquids of substantially different viscosities into a common fluid receiving chamber having a discharge orifice, discharging said liquids in a unitary stream from said chamber before said liquids are homogeneously blended, said liquids being fed separately through openings located one entirely behind the other with respect to said orifice and along the length of said chamber, said liquid of greater viscosity being fed into said chamber through said opening located closer to said orifice than another of said openings through which said liquid of lower viscosity is fed, the ratio of the rate of feed into said chamber of said liquid of lower viscosity to said liquid of greater viscosity being in the range of 1.5-1 to 3-1, applying gas under pressure to said stream in the substantially immediate vicinity of said orifice to convert said stream into a spray, subjecting said spray to gas under pressure to modify the shape of said spray and then depositing said spray onto a surface to be coated.

AUSTIN H. DOWNS.

#### REFERENCES CITED

The following references are of record in the file of this patent:

#### UNITED STATES PATENTS

Number	Name	Date
1,185,344	Philbert	May 30, 1916
1,774,694	Bateman	Sept. 2, 1930
1,863,782	Young	June 21, 1932
1,981,405	Wrede	Nov. 2, 1934
2,214,476	Peacock	Sept. 10, 1940