

F. V. EAVENSON.
COASTER WAGON.
APPLICATION FILED OCT. 23, 1903.

NO MODEL.

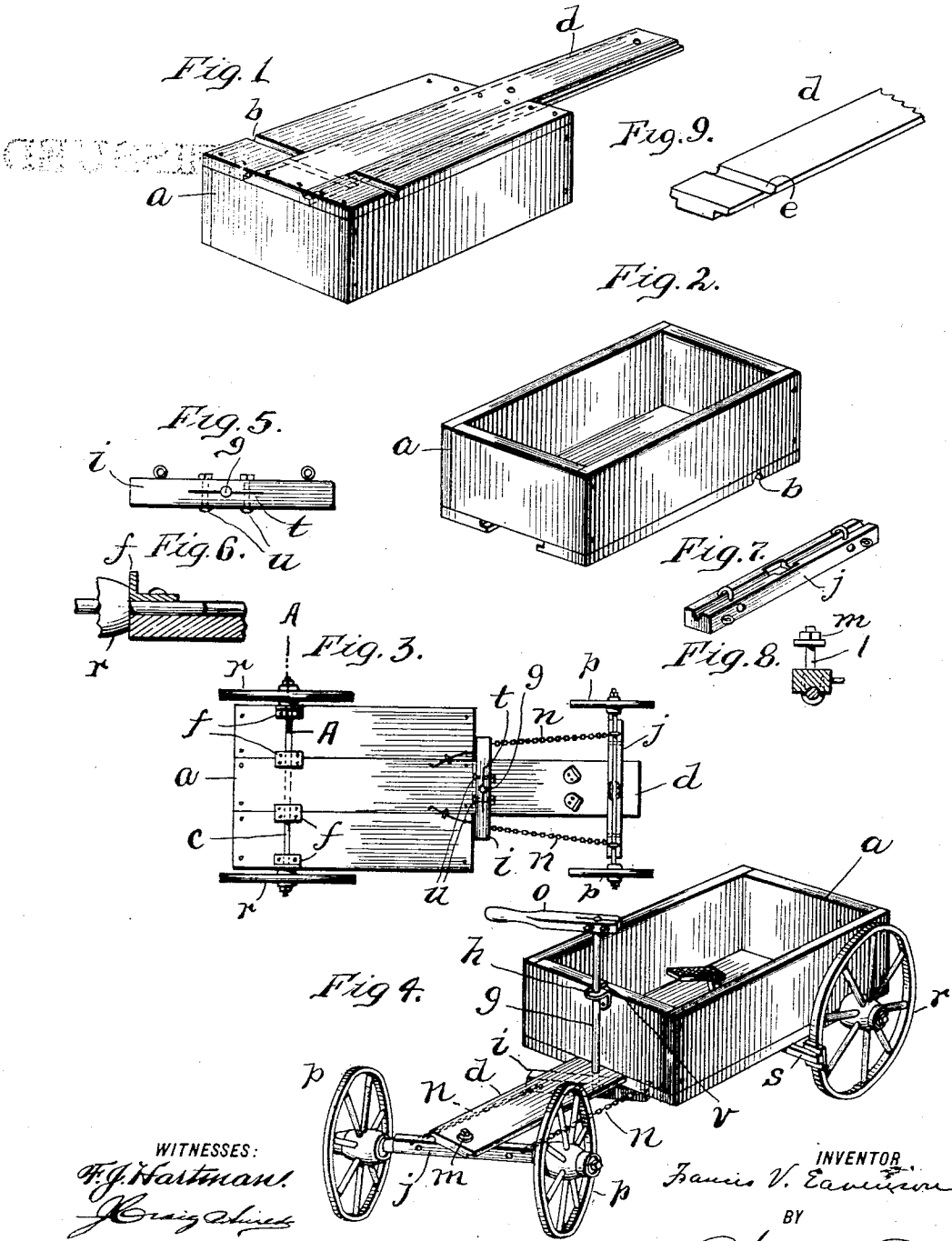

WITNESSES:
F. J. Hartman
B. Craig Shires

INVENTOR,
F. V. EAVENSON
BY
Chas. A. Pester
ATTORNEY.

UNITED STATES PATENT OFFICE.

FRANCIS V. EAVENSON, OF ST. DAVIDS, PENNSYLVANIA.

COASTER-WAGON.

SPECIFICATION forming part of Letters Patent No. 751,785, dated February 9, 1904.

Application filed October 23, 1903. Serial No. 178,173. (No model.)

REISSUED

To all whom it may concern:

Be it known that I, FRANCIS V. EAVENSON, a citizen of the United States, and a resident of St. Davids, Delaware county, Pennsylvania, have invented certain new and useful Improvements in Coaster-Wagons, of which the following is a specification.

My invention relates to improvements in wagons; and the object of my invention is to furnish certain improvements in the "coaster-wagon" for which Letters Patent of the United States were issued to me on July 7, 1903, No. 733,019, said improvements being fully described hereinafter.

In the accompanying drawings, forming part of this specification, and in which similar letters of reference indicate similar parts throughout the several views, Figure 1 is a perspective view of my wagon-body turned upside down; Fig. 2, a perspective view of the wagon-body; Fig. 3, a bottom plan of the wagon complete; Fig. 4, a perspective view of the complete wagon; Fig. 5, a plan of the bar or lower end of steering-bar; Fig. 6, an enlarged section of Fig. 3 on line A A; Fig. 7, a perspective view of the under side of bolster; Fig. 8, a transverse section of bolster, front axle, and a side elevation of pin for securing bolster pivotally to the tongue of the wagon; Fig. 9, a perspective view of upper side of the tongue detached from the body of wagon.

a is the body of the wagon, made from a packing or other box.

b is a groove formed upon the under side of the bottom of the box to receive the rear axle *c*.

d is a tongue rigidly secured to the bottom of the body *b* and furnished, preferably, upon its upper side with a groove *e*, Fig. 9, which registers with the groove *b*, the latter holding the top of the axle *c*, the former the bottom of this axle. The axle may be additionally or entirely secured by straps *f*, Figs. 3 and 6, fastened to the bottom of the box, as shown.

The tongue *d* projects out beyond the front end of the body *a*, as shown in Figs. 1, 3, and 4, and has secured to it by a bolt *l* and nut *m* a bolster *j*, as in my patent referred to.

g is a steering-bar carried by a suitable bear-

ing or bracket *h*, carried by the forward end 50 of the body *a*. The steering-bar passes down through the tongue *d* and carries upon its lower end a cross-bar *i*, the ends of which are connected by chains *n* or other equivalent means with the bolster *j*. The upper end of 55 the steering-bar *g* carries a steering handle or wheel *o*, by means of which it and the arm *i* may be turned to cause, through chains *n*, the forward wheels *p* to turn to guide the wagon.

The rear wheels *r* may be acted upon by 60 any suitable form of brake *s* in a well-known manner.

The cross-bar *i* is slotted longitudinally, as shown at *t*, Figs. 3 and 5, and is bored vertically to receive the steering-bar *g*. *u* are bolts 65 passing through the cross-bar, by means of which the slotted bar may be tightly clamped against the steering-bar. A substantially similar arrangement is shown in Fig. 4 for clamping the handle *o* to the steering-bar *g*. 70

v is a pin passing through steering-bar *g* or a washer or shoulder carried by this bar, which rests upon the bracket *h* to hold the steering-bar and connected parts in place.

Having thus described my invention, I claim 75 as new and desire to secure by Letters Patent—

1. The combination with a coaster-wagon comprising a body, a tongue rigidly secured to said body, a pair of wheels supporting the rear end of said body, and a pair of front 80 wheels pivoted to and supporting the forward end of said tongue, of a bracket secured to the front of said wagon-body, a vertical steering-bar passing through said bracket and through said tongue, an operative handle secured to 85 the top of said bar, a cross-bar secured to the bottom of said steering-bar, and chain connections between said cross-bar and the axle of the front wheels.

2. The combination in a coaster-wagon as 90 described, of a body grooved out on the bottom to receive the upper part of a rear axle and a tongue grooved out on the top to receive the lower part of said axle.

FRANCIS V. EAVENSON.

Witnesses:

GEORGE W. SELTZER,
CHARLES A. RUTTER.