



(86) Date de dépôt PCT/PCT Filing Date: 2017/11/10
 (87) Date publication PCT/PCT Publication Date: 2018/05/17
 (45) Date de délivrance/Issue Date: 2022/11/08
 (85) Entrée phase nationale/National Entry: 2019/05/10
 (86) N° demande PCT/PCT Application No.: CA 2017/051350
 (87) N° publication PCT/PCT Publication No.: 2018/085942
 (30) Priorité/Priority: 2016/11/10 (US62/420,426)

(51) Cl.Int./Int.Cl. *B01F 29/10* (2022.01),
A61J 1/00 (2006.01), *A61J 3/04* (2006.01),
A61K 31/05 (2006.01), *A61K 31/197* (2006.01),
A61K 31/352 (2006.01), *A61K 36/185* (2006.01),
A61K 47/10 (2017.01), *A61K 47/42* (2017.01),
A61K 9/02 (2006.01), *A61K 9/10* (2006.01),
A61K 9/20 (2006.01)

(72) Inventeurs/Inventors:
 DANOPOULOS, PANAGIOTA, CA;
 JOINER, MARC, CA;
 NYAT PENG WONG, SARAH, CA;
 TALEBI, VARGHA, CA;
 BADER, PATRICK-MARTIN, CA

(73) Propriétaire/Owner:

(54) Titre : PROCÉDES ET SYSTÈMES DE COMPOSITION PHARMACEUTIQUE
 (54) Title: PHARMACEUTICAL COMPOUNDING METHODS AND SYSTEMS

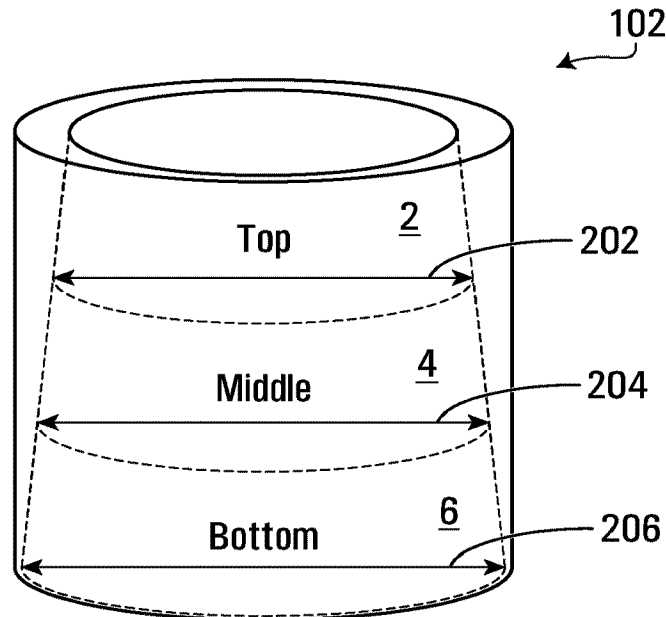

(57) Abrégé/Abstract:

The present disclosure relates to a system and process for manufacturing patient personalized pharmaceutical compositions using superimposed revolution and rotation movements for dispersing, milling, melting, and/ or de-aerating, where these superimposed revolution and rotation movements can be carried out in a single device in a pharmacy setting.

(73) Propriétaires(suite)/Owners(continued):MEDISCA PHARMACEUTIQUE INC., CA

(74) Agent: SMART & BIGGAR LLP

(12) INTERNATIONAL APPLICATION PUBLISHED UNDER THE PATENT COOPERATION TREATY (PCT)

(19) World Intellectual Property
Organization

International Bureau

(43) International Publication Date
17 May 2018 (17.05.2018)(10) International Publication Number
WO 2018/085942 A1

(51) International Patent Classification:

A61K 9/10 (2006.01) *A61K 47/42* (2017.01)
A61K 47/10 (2017.01) *B01F 9/22* (2006.01)

(21) International Application Number:

PCT/CA2017/051350

(22) International Filing Date:

10 November 2017 (10.11.2017)

(25) Filing Language:

English

(26) Publication Language:

English

(30) Priority Data:

62/420,426 10 November 2016 (10.11.2016) US

(71) Applicant: **MEDISCA PHARMACEUTIQUE INC.**
[CA/CA]; 6090 Henri-Bourassa Blvd West, St-Laurent,
Québec H4R 3A6 (CA).

(72) Inventors: **DANOPOULOS, Panagiota**; 210-7400 Boul.
Saint-Laurent, Montreal, Québec H2R 2Y1 (CA). **JOIN-
ER, Marc**; c/o Medisca Pharmaceutique INC, 6090 Hen-
ri-Bourassa West, Saint-Laurent, Quebec, H4R 3A6 (CA).

(74) Agent: **SMART & BIGGAR**; Suite 3300, 1000 De La
Gauchetiere St. W., Montreal, Québec H3B 4W5 (CA).

(81) Designated States (*unless otherwise indicated, for every
kind of national protection available*): AE, AG, AL, AM,
AO, AT, AU, AZ, BA, BB, BG, BH, BN, BR, BW, BY, BZ,
CA, CH, CL, CN, CO, CR, CU, CZ, DE, DJ, DK, DM, DO,
DZ, EC, EE, EG, ES, FI, GB, GD, GE, GH, GM, GT, HN,
HR, HU, ID, IL, IN, IR, IS, JO, JP, KE, KG, KH, KN, KP,

KR, KW, KZ, LA, LC, LK, LR, LS, LU, LY, MA, MD, ME,
MG, MK, MN, MW, MX, MY, MZ, NA, NG, NI, NO, NZ,
OM, PA, PE, PG, PH, PL, PT, QA, RO, RS, RU, RW, SA,
SC, SD, SE, SG, SK, SL, SM, ST, SV, SY, TH, TJ, TM, TN,
TR, TT, TZ, UA, UG, US, UZ, VC, VN, ZA, ZM, ZW.

(84) Designated States (*unless otherwise indicated, for every
kind of regional protection available*): ARIPO (BW, GH,
GM, KE, LR, LS, MW, MZ, NA, RW, SD, SL, ST, SZ, TZ,
UG, ZM, ZW), Eurasian (AM, AZ, BY, KG, KZ, RU, TJ,
TM), European (AL, AT, BE, BG, CH, CY, CZ, DE, DK,
EE, ES, FI, FR, GB, GR, HR, HU, IE, IS, IT, LT, LU, LV,
MC, MK, MT, NL, NO, PL, PT, RO, RS, SE, SI, SK, SM,
TR), OAPI (BF, BJ, CF, CG, CI, CM, GA, GN, GQ, GW,
KM, ML, MR, NE, SN, TD, TG).

Published:

— with international search report (Art. 21(3))

(54) Title: PHARMACEUTICAL COMPOUNDING METHODS AND SYSTEMS

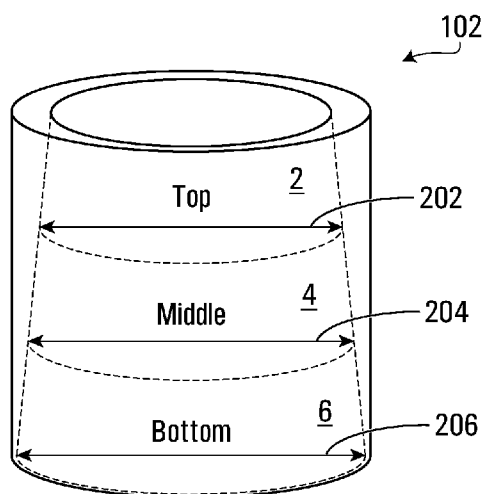

FIG. 1

(57) Abstract: The present disclosure relates to a system and process for manufacturing patient personalized pharmaceutical compositions using superimposed revolution and rotation movements for dispersing, milling, melting, and/or de-aerating, where these superimposed revolution and rotation movements can be carried out in a single device in a pharmacy setting.

WO 2018/085942 A1

PHARMACEUTICAL COMPOUNDING METHODS AND SYSTEMS

CROSS-REFERENCE TO RELATED APPLICATION

[01]

TECHNICAL FIELD

[02] The present disclosure generally relates to the field of compounding pharmaceutical compositions and, more specifically, to compounded pharmaceutical compositions having improved quality properties as well as to systems and methods for making same.

BACKGROUND

[03] Medical facilities, licensed pharmacist or physicians may produce individual pharmaceutical compositions by blending together various ingredients, such as one or more active pharmaceutical ingredient (API) and pharmaceutically acceptable excipients, diluent or solvents, to create a medicine product tailored to the needs of an individual patient. Such activities are commonly referred as pharmaceutical compounding. Practically speaking, in the context of pharmacy compounding, the pharmacist will typically prepare such product tailored to the needs of an individual patient based on a medical prescription.

[04] Pharmaceutical compounding involves blending of the composition ingredients, which is typically performed using manual mixing, for example, using a pestle and mortar. However, manually mixing ingredients can be time-consuming and is often prone to cross-contamination from poorly decontaminated or sterilized equipment used for the mixing. Along with the contamination risk, there is also the problem that performing manual mixing often results in products that face repeatability and/or quality challenges. In other words, it is often difficult to obtain compositions having consistent concentrations of API from one composition to another and/or consistent homogeneous API concentration within one preparation *per se*. This may result in substantial qualitative differences during manufacture of the same recipe, which at minimum can have an effect on the effectiveness of the recipe.

[05] In this regard, various practical devices have been previously suggested to overcome the above deficiencies of compounding pharmaceutical compositions using manual mixing.

[06] U.S. 2012/0269029 (Konietzko) describes a program-controlled mixer, which includes a control unit, a motor-driven mixing unit with a blade mixing tool, which engages into a mixing vessel, and a lift unit. The lift unit produces an axial relative motion between the blade mixing tool and the mixing vessel, to move the blade mixing tool in the mixing vessel between an upper end position and a lower one, preferably at a constant lifting speed.

[07] A deficiency associated with many mixing devices is that they often involve mixing using blades that contact the mixture causing high shearing forces, which can generate so much heat during mixing so as to degrade thermally labile API.

[08] Additionally or alternatively, many mixing devices often entrain air into the composition being mixed. The entrained air forms air bubbles in the composition modifying thereafter the specific gravity of the pharmaceutical composition. Since the specific gravity is the ratio of the density of the composition to the density of a reference substance; equivalently, it is the ratio of the mass of the composition to the mass of a reference substance for the same given volume. Variations in specific gravity of a composition can be detrimental in that such variations alters the aforementioned ratio and, accordingly, alters the API weight content which is filled in a pharmaceutical container for a given volume of composition filled in. This is particularly critical for pharmaceutical dispensing devices dispensing measured doses which need to dispense consistent amounts of API for a given volume from one device to another one, and from one dispensed volume to the next in the same dispensing device.

[09] In other cases, the entrained air must be removed in order to eliminate the air bubbles from the pharmaceutical composition and thereby improve the appearance of the pharmaceutical composition. For instance, in the production of either translucent or transparent pharmaceutical compositions, it is mandatory to remove the air bubbles since these would otherwise negatively affect the translucency or transparency of the pharmaceutical compositions by imparting opacity zones thereto. However, such de-aeration is time consuming, lowers throughput and generally requires additional vacuum configurations, which can be cumbersome and increase overall manufacturing costs.

[10] Additionally or alternatively, many mixing devices often require mixing in device-specific mixing containers, which thus requires an additional step of decanting the pharmaceutical mixture into a dispensing device container, thereby increasing the risk of material loss during the decanting procedure. Device-specific containers also limit the volume and/or mass of materials that can be mixed to the specifications of such containers, which is not always ideal from a practical perspective. Device-specific containers also require implementing strict cleaning / sterilization procedures to avoid cross-contamination risk when one wishes to reuse the same mixing containers, which can be cumbersome and time-consuming. Otherwise, operation costs and waste are increased when container are used and are discarded after each mixing procedure, i.e., when used as single-use mixing containers.

SUMMARY

[11] This Summary is provided to introduce a selection of concepts in a simplified form that are further described below in the Detailed Description. This Summary is not intended to identify key aspects or essential aspects of the claimed subject matter.

[12] There is a need to provide improved compounded pharmaceutical composition having improved quality properties as well as devices and methods for making same, which alleviate at least in part the deficiencies of the existing devices and methods for making compounded pharmaceutical compositions.

[13] In one embodiment, the present disclosure aims to at least address how to reduce qualitative differences during manufacturing of compounded pharmaceutical composition mixtures, and/or increase productivity, and/or improve effectiveness of compounded pharmaceutical composition mixtures.

[14] In one broad aspect, the present disclosure relates to a composition comprising an active pharmaceutical ingredient (API) dispersed in a pharmaceutically acceptable excipient, carrier or diluent, the composition exhibiting a concentration gradient of the API with $\leq 6\%$, or $\leq 5\%$, or $\leq 4\%$, or $\leq 3\%$, or $\leq 2\%$, or $\leq 1\%$, or about 0% relative standard deviation (RSD) when measured by high-performance liquid chromatography (HPLC), wherein the concentration is that of at least

top, middle and bottom layers of the composition within the container, and wherein the composition is personalized for a patient.

[15] In another broad aspect, the present disclosure relates to a composition comprising an active pharmaceutical ingredient (API) dispersed in a pharmaceutically acceptable excipient, carrier or diluent, the composition exhibiting a concentration gradient of the API with $\leq 6\%$, or $\leq 5\%$, or $\leq 4\%$, or $\leq 3\%$, or $\leq 2\%$, or $\leq 1\%$, or about 0% relative standard deviation (RSD) when measured by high-performance liquid chromatography (HPLC), wherein the concentration is that of at least top, middle and bottom layers of the composition within the container, and wherein the composition is personalized for a patient, the composition having a specific gravity which is within 20% of corresponding specific gravity of the pharmaceutically acceptable excipient, diluent or carrier in absence of the API.

[16] In yet another aspect, the present disclosure relates to a troche comprising an active pharmaceutical ingredient (API) dispersed in a pharmaceutically acceptable excipient, carrier or diluent, wherein the API is thermolabile at a temperature above $60\text{ }^{\circ}\text{C}$, and the troche includes less than 1% degradation products of the API, wherein the troche is personalized for a patient

[17] In yet another aspect, the present disclosure relates to a compounding method, comprising: providing a container including therein a pharmaceutically acceptable excipient, carrier or diluent, and an active pharmaceutical ingredient (API); subjecting the container to superimposed revolution and rotation movements to disperse the pharmaceutically acceptable excipient, carrier or diluent, and the API and produce a composition exhibiting a concentration gradient of the API with $\leq 6\%$, or $\leq 5\%$, or $\leq 4\%$, or $\leq 3\%$, or $\leq 2\%$, or $\leq 1\%$, or about 0% relative standard deviation (RSD) when measured by high-performance liquid chromatography (HPLC), wherein the concentration is that of at least top, middle and bottom layers of the composition within the container, and wherein the composition is personalized for a patient.

[18] In yet another aspect, the present disclosure relates to a compounding method, comprising: providing a container including therein a pharmaceutically acceptable excipient, carrier or diluent having a first specific gravity, and an active pharmaceutical ingredient (API); and subjecting the container to superimposed revolution and rotation movements to disperse the pharmaceutically acceptable excipient, carrier or diluent, and the API and produce a composition having a second

specific gravity and exhibiting a concentration gradient of the API with $\leq 6\%$, or $\leq 5\%$, or $\leq 4\%$, or $\leq 3\%$, or $\leq 2\%$, or $\leq 1\%$, or about 0% relative standard deviation (RSD) when measured by high-performance liquid chromatography (HPLC), wherein the concentration is that of at least top, middle and bottom layers of the composition within the container, and wherein the composition is personalized for a patient, wherein the second specific gravity is within 50% , or 40% , or 30% , or 20% , or 10% , of the first specific gravity without introducing air into the composition.

[19] In yet another aspect, the present disclosure relates to a compounding method, comprising: providing a container including therein gelatin gum base particles; subjecting the container to first superimposed revolution and rotation movements to disperse the particles and produce a melt composition; adding an active pharmaceutical ingredient (API) into the melt to obtain an API-containing melt; subjecting the container comprising the API-containing melt to second superimposed revolution and rotation movements to disperse the API-containing melt and obtain a dispersed melt composition; and cooling the dispersed melt composition to obtain a dispersed solid composition, wherein the dispersed solid composition is personalized for a patient.

[20] In yet another aspect, the present disclosure relates to a compounding method, comprising: providing a container including therein particles of a pharmaceutically acceptable excipient, pharmaceutically acceptable carrier, or an active pharmaceutical ingredient (API), wherein the particles have a starting D_{50} ; subjecting the container to first superimposed revolution and rotation movements in presence of grinding beads to produce a milled composition including particles having a milled D_{50} , wherein the starting D_{50} to milled D_{50} represent a ratio of at least 2.5, incorporating into the milled composition at least one of a pharmaceutically acceptable excipient, pharmaceutically acceptable carrier, or API and removing the grinding media from the container before or after said incorporating, and subjecting the container to second superimposed revolution and rotation movements to obtain a composition.

[21] In one embodiment, any one of the herein described method is performed in a pharmacy setting.

[22] In another embodiment, any one of the herein described method is performed under the supervision of a licensed pharmacist.

[23] In another embodiment, any one of the herein described method is performed by a licensed pharmacist or a licensed physician.

[24] In one embodiment, the composition can be a cream, ointment, lotion, emulsion, gel, suspension, powder, liquid solution, colloidal dispersion, troche or syrup.

[25] In one embodiment, the composition of the present disclosure is a composition which is personalized for a patient.

[25a] In yet another aspect, the present disclosure relates to a method to obtain a solid, semi-solid, or chewable composition, comprising: providing a container including therein a plurality of gelatin-based material pieces; subjecting the container to first movements configured for elevating a temperature of the material sufficient to melt the plurality of pieces and obtain a pourable composition; adding an active pharmaceutical ingredient (API) into the pourable composition to obtain an API-containing composition; and cooling the dispersed composition to obtain the solid, semi-solid, or chewable composition.

[25b] In yet another aspect, the present disclosure relates to a method to obtain a solid, semi-solid, or chewable composition in a desired shape, comprising: providing a container with a plurality of gelatin-based material pieces therein; subjecting the container to movements configured for causing an elevation in temperature in the material sufficient to melt the plurality of pieces and obtain a pourable composition; and pouring the composition into a mold having the desired shape and cooling the composition to obtain the solid, semi-solid, or chewable composition in said desired shape.

[25c] In yet another aspect, the present disclosure relates to a method for melting a troche or suppository base, comprising: providing a container comprising pieces of the troche or suppository base; and subjecting the container to movements that induce an elevation in temperature of the troche or suppository base sufficient for melting the pieces into a pourable composition.

[25d] In yet another aspect, the present disclosure relates to a method of operating a device configured for performing superimposed revolution and rotation movements on a container, comprising selecting an operating parameter from a plurality of operating parameters, wherein the

plurality of operating parameters includes an operating parameter associated with performing superimposed revolution and rotation movements on a container and for melting pieces of a gelatin-based material contained in the container into a pourable composition.

[25e] In yet another aspect, the present disclosure relates to use of a device for melting pieces of a gelatin-based material into a pourable composition, the device configured for subjecting a container comprising the gelatin-based material to movements that induce an elevation in temperature of the material sufficient to melt the gelatin-based material.

[25f] In yet another aspect, the present disclosure relates to a device for use in melting a gelatin-based material into a pourable composition, the device configured for performing movements on a container including said gelatin-based material, the movements inducing an elevation in temperature sufficient for melting the material.

[25g] In yet another aspect, the present disclosure relates to a device configured for presenting a user with a set of predetermined operating parameters for operating the device, the set of operating parameters comprising an operating parameter associated with performing superimposed revolution and rotation movements on a container for melting pieces of a gelatin-based material contained in the container into a pourable composition.

[25h] In yet another aspect, the present disclosure relates to a method of operating a device configured for performing superimposed revolution and rotation movements on a container, comprising selecting an operating parameter from a plurality of operating parameters, wherein the plurality of operating parameters includes an operating parameter associated with performing superimposed revolution and rotation movements on a container, wherein the movements are sufficient for melting a plurality of pieces of gelatin gum based material t contained in the container into a pourable composition for making a troche or suppository.

[25i] In yet another aspect, the present disclosure relates to a compounding method, comprising: placing a plurality of pieces of a gelatin gum based material into a container; and melting the plurality of pieces to obtain a pourable composition for making a troche or suppository by subjecting the container to superimposed revolution and rotation movements.

[25j] In yet another aspect, the present disclosure relates to a device for use in melting a plurality of pieces of gelatin gum based material for making a troche or suppository, wherein the device is configured for performing superimposed revolution and rotation movements on a container containing said plurality of pieces, wherein the movements induce an elevation in temperature sufficient for melting the plurality of pieces into the pourable composition.

[25k] In yet another aspect, the present disclosure relates to a device configured for presenting a user with a set of predetermined operating parameters for operating the device, the set of operating parameters comprising an operating parameter associated with performing superimposed revolution and rotation movements on a container, wherein the movements are sufficient for melting a plurality of pieces of a gelatin gum based material contained in the container into a pourable composition for making a troche or suppository.^

[25l] In yet another aspect, the present disclosure relates to a dispensing device comprising a composition and being configured for dispensing the composition, the device further comprising a container containing the composition and the composition comprising an active pharmaceutical ingredient (API) dispersed in a pharmaceutically acceptable excipient, carrier or diluent, the composition exhibiting a concentration gradient of the API with $\leq 3\%$ relative standard deviation (RSD) when measured by high-performance liquid chromatography (HPLC) from at least top, middle and bottom layers of the composition within the dispensing container.

[25m] In yet another aspect, the present disclosure relates to a compounding method, comprising: placing a pharmaceutically acceptable excipient, carrier or diluent having a first specific gravity and an active pharmaceutical ingredient (API) into a container; and homogenizing and deaerating the API and the pharmaceutically acceptable excipient, carrier or diluent by subjecting the container to superimposed revolution and rotation movements to produce a composition having a second specific gravity, wherein the second specific gravity is within 50% of the first specific gravity without introducing air into the composition.

[25n] In yet another aspect, the present disclosure relates to a compounding method, comprising: placing a pharmaceutically acceptable excipient, carrier or diluent having a first specific gravity and an active pharmaceutical ingredient (API) into a container, wherein the API is thermally labile at a temperature ≥ 50 °C; homogenizing the API and the pharmaceutically acceptable excipient, carrier or diluent by subjecting the container to superimposed revolution and rotation movements to produce a composition, wherein the composition includes less than 1% degradation products of the API.

[25o] In yet another aspect, the present disclosure relates to a compounding method, comprising: placing particles of an active pharmaceutical ingredient (API) in a container, wherein the particles have a starting D_{50} ; and micronizing the API by subjecting the container to superimposed revolution and rotation movements in presence of grinding media to obtain API particles having a milled D_{50} , wherein the starting D_{50} to milled D_{50} represent a ratio of at least 2.5.

[26] For the purpose of the present disclosure, the expressions “compounded pharmaceutical composition” and “composition personalized for a patient” are used interchangeably and refer in particular to those single compositions which are assembled in a medical facility, or by a licensed pharmacy (as opposed to those compositions made in batch in a pharmaceutical industrial plant) where a pharmacist combines, mixes, or alters ingredients in response to a doctor’s prescription to create a medicine tailored to the medical needs of an individual patient. In other words, the type and/or concentration of at least one of the API, the excipient, diluent or carrier is customized to create a composition tailored to the medical needs of the patient.

[27] Compounding may, thus, be used in a variety of situations where a patient cannot be treated with a standard, commercially available, FDA- (or other regulatory body) approved medicine.

[28] For example, a patient might be allergic to the kind of dye used in a commercially available medication. In this case, the compounding personnel would formulate the medication without the dye or with another dye. Or, sometimes elderly patients or children who cannot swallow tablets need their medicine in a liquid or suppository form that is not commercially available. Suspensions possess certain advantages over other dosage forms. Some drugs are insoluble in all acceptable media and must, therefore, be administered as a tablet, capsule, or as a suspension. Because of their liquid character, suspensions represent an ideal dosage form for patients who have difficulty swallowing

tablets or capsules. This factor is of particular importance in administration of drugs to children. Suspensions of insoluble drugs may also be used externally, often as protective agents.

[29] In addition, disagreeable tastes can be masked by a suspension of the drug or a derivative of the drug, an example of the latter being the drug chloramphenicol palmitate. Finally, drugs in

suspension are *chemically* more stable than in solution. This is particularly important with certain antibiotics and the pharmacist is often called on to prepare such a suspension just prior to the dispensing of the preparation.

[30] Sometimes, a patient may require a special API dosage and thus, the compounding personnel will customize the API concentration in the compounded composition.

[31] In other cases, a patient may be allergic to the API in the commercially available medication and the compounding personnel will thus customize the composition by replacing the API with another one, hypoallergenic for the patient.

[32] The person of skill will recognize that such are examples of a composition which is personalized for a patient.

[33] All features of embodiments which are described in this disclosure and are not mutually exclusive can be combined with one another. Elements of one embodiment can be utilized in the other embodiments without further mention. Other aspects and features of the present invention will become apparent to those ordinarily skilled in the art upon review of the following description of specific embodiments in conjunction with the accompanying Figures.

BRIEF DESCRIPTION OF FIGURES

[34] A detailed description of specific embodiments is provided herein below with reference to the accompanying drawings in which:

[35] Fig. 1 shows a cross section view of a jar including a composition which is personalized for a patient, where the container is virtually separated in top, middle and bottom sections, each including respective top, middle and bottom layers of the composition, in accordance with an implementation of the present invention;

[36] Fig. 2 is a flow diagram of a process to obtain the patient personalized composition of Fig. 1, in accordance with an implementation of the present invention;

[37] Fig. 3 is a flow diagram of a variant of the process of Fig. 2 including operating superimposed revolution and rotation movements to obtain a melt containing an API, and molding

the melt into a solid form of a patient personalized composition, in accordance with an implementation of the present invention;

[38] Fig. 4 is a flow diagram of a variant of the process of Fig. 2 including operating superimposed revolution and rotation movements in presence of grinding media to reduce particle size distribution (PSD) of at least one ingredient of a patient personalized composition to a desired target PSD, in accordance with an implementation of the present invention;

[39] Fig. 5 is a flow diagram of a variant of the process of Fig. 2 including operating superimposed revolution and rotation movements to disperse (mix) and de-aerate a patient personalized composition, in accordance with an implementation of the present invention;

[40] Fig. 6 shows a system for compounding a pharmaceutical composition using superimposed revolution and rotation movements, in accordance with an implementation of the present invention;

[41] Fig. 7 shows a top view of the jar of Fig. 1 for use with the system of Fig. 6, in accordance with an implementation of the present invention;

[42] Fig. 8 shows a side isometric view of a variant dispensing jar for use with the system of Fig. 6, in accordance with an implementation of the present invention;

[43] Fig. 9 shows a side isometric view of dispensing jars, each having a respective body having a different size from one another, for use with the system of Fig. 6, in accordance with an implementation of the present invention;

[44] Fig. 10A shows a cross-sectional view of jar which contains a specific amount of composition, in accordance with an implementation of the present invention;

[45] Fig. 10B shows a cross-sectional view of container placed inside jar, where the container contains the same specific amount of composition as in Fig. 10A, in accordance with an implementation of the present invention;

[46] Fig. 11 shows a top isometric view of an adapter for use with a container for use with the system of Fig. 6, in accordance with a first implementation of the present invention;

[47] Fig. 12 shows a side view of the container of Fig. 8, including details of the external threads on the nozzle of the container, in accordance with an implementation of the present invention;

[48] Fig. 13 shows a top isometric view of a variant of the adapter of Fig. 11, in accordance with a second implementation of the present invention;

[49] Fig. 14 shows a cross-sectional view of container secured to an inside surface of a jar via an adaptor, in accordance with an implementation of the present invention;

[50] Fig. 15 shows a top isometric view of a variant of the adapter of Fig. 11, in accordance with a third implementation of the present invention;

[51] Fig. 16 shows a top isometric view of containing system which includes the adaptor of Fig. 15 mounted onto the container of Fig. 8, in accordance with an implementation of the present invention;

[52] Fig. 17 shows a cross sectional view of a containing system placed inside a jar, in accordance with an implementation of the present invention;

[53] Fig. 18A shows a top view of an adaptor having three prongs for use with a container, in accordance with an implementation of the present invention;

[54] Fig. 18B shows a side view of the adaptor of Fig. 18A, in accordance with an implementation of the present invention;

[55] Fig. 19 shows a top isometric view of adaptor of Fig. 18A in which is located the container, in accordance with an implementation of the present invention;

[56] Fig. 20 show a cross-sectional view of the containing system placed inside a jar, in accordance with an implementation of the present invention;

[57] Fig. 21 shows a top isometric view of an adaptor having four prongs for use with a container, in accordance with an implementation of the present invention;

[58] Fig. 22 shows a top isometric view of adaptor with a rubberized exterior peripheral band 2012, in accordance with an implementation of the present invention;

[59] Fig. 23A shows a top isometric view of adaptor with a retention element on the base of the adaptor, in accordance with an implementation of the present invention;

[60] Fig. 23B shows a cross-sectional view of a jar having a retention element on the inside surface thereof corresponding to the retention element on the adaptor of Fig. 23A, in accordance with an implementation of the present invention;

[61] Fig. 24 shows a cross-sectional view of adaptor of Fig. 18A receiving the container and located inside jar, which has a heat conductive material located in between the prong and the inside surface of the jar, in accordance with an implementation of the present invention;

[62] Fig. 25 shows a cross-sectional view of adaptor of Fig. 18A receiving the container and located inside a jar, which has a thermally insulating material located in between the prong and the inside surface of the jar, in accordance with an implementation of the present invention;

[63] Fig. 26 shows a side elevation of insert that may be removably positioned within the jar, in accordance with an implementation of the present invention;

[64] Fig. 27 shows a top view of a jar containing grinding media, in accordance with an implementation of the present invention;

[65] Fig. 28 represents non-limiting graphs showing the interaction profiles of combined effects on SD percent of progesterone in a composition prepared using superimposed revolution and rotation movements based on parameters varying revolution, rotation and time, in accordance with an implementation of the present invention;

[66] Fig. 29 represents non-limiting graphs showing leverage plots of parameters with significant effects with respect to SD of percent progesterone in a composition prepared using superimposed revolution and rotation movements based on parameters varying revolution, rotation and time, in accordance with an implementation of the present invention;

[67] Fig. 30 represents non-limiting graphs showing implementation of a desirability algorithm for optimization of dispersing (mixing) of the progesterone composition of Fig. 28 and Fig. 29, where the desirability is set such that SD of percentage progesterone is zero and time setting is

minimized to the lowest value (i.e., 10 seconds), in accordance with an implementation of the present invention;

[68] Fig. 31 represents non-limiting graphs showing initial particle size distribution (PSD) of sodium chloride (A) and the PSD after being processed according to prior art mortar and pestle dispersing (mixing) process (B), when processed using superimposed revolution and rotation movements in presence of grinding media spheres of 8 mm (C) or cylinders (D), in accordance with an implementation of the present invention;

[69] Fig. 32 represents non-limiting graphs showing initial particle size distribution (PSD) of Gabapentin (A) and the PSD after being processed according to prior art mortar and pestle dispersing (mixing) process (B), when processed using superimposed revolution and rotation movements in presence of grinding media spheres of 8 mm (C) or cylinders (D), in accordance with an implementation of the present invention;

[70] Fig. 33 shows a typical gum base gelatin particle unaltered from the manufacturers' container (left) and a plurality of these particles contained in the dispersion container (right). The block has a maximal extent size of about 1 inch, in accordance with an implementation of the present invention;

[71] Fig. 34 shows gum base gelatin particles which have been cut down from the initial size present in the manufacturers' container (left) and a plurality of these particles contained in the dispersion container (right). The cut down particles have a size of less than about 0.5 inch, in accordance with an implementation of the present invention;

[72] Fig. 35A-35E shows examples of gum base in the dispersion container that completely melted (35A), partially melted (35B, 35C and 35D), and did not melt (35E), in accordance with an implementation of the present invention;

[73] Fig. 36 represents a non-limiting graph showing melting of gum base gelatin when processed using superimposed revolution and rotation movements based on parameters of constant time and increasing G Force, in accordance with an implementation of the present invention;

[74] Fig. 37 represents a non-limiting graph showing melting of gum base gelatin when processed using superimposed revolution and rotation movements based on parameters of constant G force and increasing time, in accordance with an implementation of the present invention;

[75] Fig. 38 represents a non-limiting graph showing melting of gum base gelatin when processed using superimposed revolution and rotation movements based on parameters of constant G force and time, while increasing the mass, in accordance with an implementation of the present invention;

[76] Fig. 39 represents a non-limiting graph showing percentage de-aeration of a personalized composition when processed using superimposed revolution and rotation movements based on parameters of constant time and variable G force, in accordance with an implementation of the present invention;

[77] Fig. 40 represents a non-limiting graph showing percentage de-aeration of a personalized composition when processed using superimposed revolution and rotation movements based on parameters of constant G force and variable time, in accordance with an implementation of the present invention;

[78] Fig. 41 represents a non-limiting graph showing particle size (μm) with respect to D10, D50 and D90 of 23 gram of NaCl when processed using superimposed revolution and rotation movements based on parameters of constant G Force in presence of grinding media or when processed with control mortar and pestle, in accordance with an implementation of the present invention;

[79] Fig. 42 represents a non-limiting graph showing particle size (μm) with respect to D10, D50 and D90 of 50 gram of NaCl when processed using superimposed revolution and rotation movements based on parameters of constant G Force in presence of grinding media or when processed with control mortar and pestle, in accordance with an implementation of the present invention;

[80] Fig. 43 represents a non-limiting graph showing particle size (μm) with respect to D10, D50 and D90 of 22.9 gram of NaCl when processed using superimposed revolution and rotation

movements based on parameters of 60 seconds in presence of grinding media or when processed with control mortar and pestle, in accordance with an implementation of the present invention;

[81] Fig. 44 represents a non-limiting graph showing temperature increase (gain in degrees Celsius) when processing NaCl when processed using superimposed revolution and rotation movements based on parameters of constant G force and increasing time period in presence of grinding media, in accordance with an implementation of the present invention;

[82] Fig. 45 represents a non-limiting graph showing temperature increase (gain in degrees Celsius) when processing NaCl when processed using superimposed revolution and rotation movements based on parameters of constant time period and increasing G force in presence of grinding media, in accordance with an implementation of the present invention;

[83] In the drawings, embodiments are illustrated by way of example. It is to be expressly understood that the description and drawings are only for the purpose of illustrating certain embodiments and are an aid for understanding. They are not intended to be a definition of the limits of the invention.

DETAILED DESCRIPTION

[84] Illustrative embodiments of the disclosure will now be more particularly described. The same features are denoted in all figures by the same reference signs. While the making and using of various embodiments of the present invention are discussed in detail below, it should be appreciated that the present invention provides many applicable inventive concepts that can be embodied in a wide variety of specific contexts. Specific embodiments discussed herein are merely illustrative of specific ways to make and use the disclosure and do not delimit the scope of the disclosure.

Composition

[85] A composition of the present disclosure includes one or more ingredient which is tailored to medical needs of an individual patient. The composition further includes one or more characteristics which, when compared to compositions obtained with prevalent compounding methods that make use, e.g., of manual mixing, may constitute an improvement from a safety and/or quality and/or effectiveness perspective.

[86] In one embodiment, the composition of the present disclosure can be a cream, ointment, lotion, emulsion, gel, suspension, powder, liquid solution, colloidal dispersion, troche or syrup. For the purpose of the present disclosure, the compounding composition of the present description may be packaged in a metered dose device and/or a unit dose package. A metered dose device allows administering a dose of compounding composition, the dose of compounding composition being metered by weight or by volume. In one non-limiting example, the metered dose device is an inhaler comprising a canister, a metering valve and an actuator. The canister encloses the compounding composition, while the metering valve allows a metered dose of the compounding composition to be dispensed at each actuation of the actuator, the actuator being a mouthpiece in this example. In another non-limiting example, the metered dose device comprises a container enclosing the compounding composition, an actuator manually operated, and a metering valve allowing a metered dose of the compounding composition to be dispensed at each actuation of the actuator. A unit dose package (also referred as “individual package”) allows the compounded composition to be dispensed more safely and efficiently by enclosing each unit dose in a different recipient. A unit dose is typically a dose of medication comprising a dose of at least one compounded composition that is intended to be administrated at once. The recipients may comprise paper, cardboard, plastic, metal and/or glass materials. In one non-limiting example, the recipients are paper envelopes. In another non-limiting example, the recipients are reusable boxes. In one non-limiting example, the recipients are single-use plastic boxes with a detachable paper lid. The recipients may be tagged, marked with information, such as a name of a patient, a name of a medication, a barcode and/or a moment (i.e. a day, a date and/or a moment of the day) at which the unit dose is intended to be administrated. In one non-limiting example, each recipient is tagged with a day of the week and a meal: Monday-breakfast, Monday-diner, Tuesday-breakfast, etc. The unit dose package may be provided by manually packaging the unit doses or by an automated packaging system.

[87] In a first practical implementation, the composition of the present disclosure includes at least one active pharmaceutical ingredient (API) dispersed (mixed) in a pharmaceutically acceptable excipient, diluent or carrier in such a way that the composition has substantially the same API concentration in a top layer, a middle layer and a bottom layer of the composition, as measured with high-performance liquid chromatography (HPLC). Such composition will be referred to in this text as being a “substantially homogeneous composition”.

[88] The concept of having substantially the same API concentration in a top, middle and bottom layer of the composition is illustrated in Fig. 1A, which shows a cross-sectional view of a container **102** including a patient personalized composition, where the container **102** is virtually separated in top, middle and bottom sections, each including respective top **2**, middle **4** and bottom **6** layers of the composition. The concentration of the API dispersed (mixed) in the composition is then measured in each of layers **2**, **4** and **6** using a suitable technique, such as HPLC. The standard deviation (SD) between the API concentrations of the three layers **2**, **4** and **6** for a given composition is then determined. The relative standard deviation (%RSD), which expresses the precision and repeatability of an assay, is then calculated based on the ratio of the standard deviation to the mean.

[89] In a non-limiting embodiment, the composition exhibits a concentration gradient of the API having $\leq 3\%$ relative standard deviation (%RSD), or $\leq 2\%$ RSD, or $\leq 1\%$ RSD, when measured at least at the top **2**, middle **4** and bottom **6** layers of the composition using HPLC. In a non-limiting embodiment, the concentration gradient of the API is nil (about 0% RSD), when measured at least at the top **2**, middle **4** and bottom **6** layers of the composition using HPLC.

[90] In one embodiment, the API can be present in an amount of ≤ 80 wt.% relative to total weight of the composition. For example, the API can be present in an amount selected in the range of 0.05 wt.% to 80 wt.%, or 0.05 to 70 wt.%, or 0.05 to 60 wt.%, or 0.05 to 50%, or 0.05 to 50 wt.%, or any other desired amount.

[91] In a non-limiting embodiment, the composition includes at least a second API dispersed (mixed) in the pharmaceutically acceptable excipient, carrier or diluent, the second API, and the composition exhibiting a concentration gradient of the at least second API having $\leq 6\%$ RSD, or $\leq 3\%$ RSD, or $\leq 2\%$ RSD, or $\leq 1\%$ RSD, when measured at least at the top **2**, middle **4** and bottom **6** layers of the composition using HPLC. In a non-limiting embodiment, the concentration gradient of the at least a second API is nil (about 0% RSD), when measured at least at the top **2**, middle **4** and bottom **6** layers of the composition using HPLC.

[92] In a non-limiting embodiment, the concentration gradient of the at least second API can be approximately the same as the concentration gradient of the first API.

[93] In another non-limiting embodiment, the concentration gradient of the at least second API is significantly different than the concentration gradient of the first API.

[94] Different types of pharmaceutical compositions have been prepared by the present inventors with the above low %RSD values.

[95] In a second practical implementation, the composition of the present disclosure includes an API dispersed (mixed) in a pharmaceutically acceptable excipient, diluent or carrier in such a way that the composition has reduced air entrapment levels.

[96] One practical way of assessing air entrapment levels in the composition is to measure the specific gravity of the composition before and after the dispersion (mixing) procedure and/or of a composition prepared with the herein described process to a composition prepared with a dispersion procedure of the prior art, such as mixing with an electronic mortar and pestle.

[97] For example, it has been observed by the present inventors that compounding pharmaceutical ingredients using prior art processes such as the electronic mortar and pestle can incorporate significant amounts of air into the composition under certain circumstances (i.e., > 30% variation in the composition's specific gravity). In such cases, the air entrapped in the composition creates air bubbles which are undesirable from a product quality perspective. It is, thus, common in the art to further process compositions which have been mixed with the electronic mortar and pestle with another device to remove the air bubbles entrapped therein. In such cases, the compounding process can thus include the use of at least two devices, the electronic mortar and pestle and another device such as the Unguator™ (Gako International GmbH), to remove entrapped air. The use of two devices can be cumbersome, increase operation costs, delays, likelihood of cross-contamination, material loss (e.g., through decanting from one container suitable for mixing with the electronic mortar and pestle to another container suitable for the Unguator), and/or other undesirable effects which will become apparent to the person of skill in view of the present disclosure.

[98] In contrast, and as will be further discussed later in this text, the herein described superimposed revolution and rotation movements, typically, will not introduce air during the dispersing (mixing) process, and if the starting composition ingredients (i.e., before dispersion) initially include air entrapped therein, the herein described superimposed revolution and rotation

movements will deaerate the composition while dispersing (mixing) the ingredients. This can be advantageous, in particular when the herein described superimposed revolution and rotation movements is implemented in a single device, as will be further discussed later in this text.

[99] In this particular implementation, the patient personalized composition of the present disclosure includes an API dispersed (mixed) in a pharmaceutically acceptable excipient, diluent or carrier. The composition has a specific gravity which is within 20%, or within 10%, or within 5%, or within 2%, of the specific gravity of the pharmaceutically acceptable carrier, diluent or excipient in absence of the API. Preferably, such composition exhibits a concentration gradient of the API with $\leq 6\%$ RSD, or $\leq 3\%$ RSD, or $\leq 2\%$ RSD, or $\leq 1\%$ RSD, or RSD being nil (about 0%), when measured at least at the top **2**, middle **4** and bottom **6** layers of the composition using HPLC. relative standard deviation (RSD) when measured at least at a top, middle and bottom layers of the composition by high-performance liquid chromatography (HPLC).

[100] In one embodiment, the composition of the present disclosure includes an API dispersed (mixed) in a pharmaceutically acceptable excipient, diluent or carrier, and has a specific gravity which is substantially identical to the specific gravity of the pharmaceutically acceptable carrier, diluent or excipient without the API.

[101] In a third practical implementation, the composition of the present disclosure includes an API which is thermally labile at a temperature above 50 °C, or above 60 °C, or above 80 °C. The API is dispersed (mixed) in a pharmaceutically acceptable excipient, diluent or carrier. This composition includes less than 1.0% degradation products of the thermally labile API. The person of ordinary skill will readily appreciate that the percentage here represents a wt./wt. percentage relative to the total weight of the thermally labile API added into the composition before dispersion (mixing).

[102] In one non-limiting embodiment, the amount of degradation products of the thermally labile API represents less than 0.75%, 0.5%, 0.1%, 0.05%, or 0.01% wt./wt. percentage relative to the total weight of the thermally labile API added into the composition before dispersion.

[103] For the purpose of the present specification, a thermally labile API is an active pharmaceutical compound that is altered or degrades when exposed to high temperatures,

e.g. above 50 °C, or above 60 °C, or above 80 °C, or more. Typically, compounding methods that make use of blades for mixing will generate high temperatures, which can alter or degrade thermally labile API to a certain extent such that it increases costs and/or reduces yield of composition having effective API concentrations and/or produces unwanted degradation and/or alteration of the API, possibly generating by-products. In certain prior art compounding methods that make use of blades, it can be quite common to obtain dispersed composition having more than 1.5% degradation products of thermally labile API.

[104] The reader will readily understand that quantification of API degradation product levels in the dispersed composition can be performed using one of a variety of chromatographic or spectroscopic techniques known in the art, including HPLC, thin-layer chromatography (TLC), High performance thin layer chromatography (HPTLC), Atomic absorption spectroscopy (AAS), and the like.

[105] In a fourth practical implementation, the composition of the present disclosure is in the form of a molded troche and includes an API dispersed in a pharmaceutically acceptable excipient, diluent or carrier. The API is thermolabile at a temperature above 60 °C and the composition includes less than 1.0% degradation products of the thermally labile API wt./wt. percentage relative to the total weight of the thermally labile API added into the composition before dispersion.

[106] In one non-limiting embodiment, the amount of degradation products of the thermally labile API in the troche represents less than 0.75%, 0.5%, 0.1%, 0.05%, or 0.01% wt./wt. percentage relative to the total weight of the thermally labile API added into the composition before dispersion.

[107] In a specific embodiment, the troche is a chewable troche.

[108] In a specific embodiment, the troche includes a gum base gelatin.

[109] The troche can have similar features as those set forth previously with respect to the composition, namely a concentration gradient of the API with $\leq 6\%$ RSD, or $\leq 3\%$ RSD, or $\leq 2\%$ RSD, or $\leq 1\%$ RSD, or RSD being nil (about 0%), when measured at least at a top, middle and bottom layers of the troche by high-performance liquid chromatography (HPLC)

[110] A troche (also interchangeably referred to in the text as a “lozenge”) is intended to be held in the mouth or pharynx and contains one or more API(s) either dissolved or dispersed in a base. Troches are typically used for patients who have difficulty swallowing solid oral dosage forms (for example, paediatric or geriatric patients) as well as for API(s) which should be released slowly to yield a constant amount of drug in the oral cavity or to coat the throat tissues with the API(s). Commercial lozenges are made by moulding or by compression.

[111] Compression techniques are typically used when manufacturing solid troches that are intended to slowly dissolve or disintegrate in the mouth. Compression is also advisable when incorporating thermolabile APIs, as there is no excessive heat involved when compressing the troche ingredients.

[112] Moulding techniques are typically used when manufacturing solid, soft or chewable troches and in particular, when one wishes to impart a specific shape to the troche. Moulding techniques usually involve high temperature processing of the ingredients to obtain a melt, dispersing the API in the melt to obtain an API-containing melt, and casting the dispersed API-containing melt into a mold having a desired shape, and cooling the API-containing melt into the desired shape. Because of the high temperatures (e.g., 90-100 °C) usually involved with moulding, troches made with this technique typically do not include thermolabile APIs, as thermolabile APIs will usually degrade or convert to by-products in presence of such high temperatures. This in turn effectively limits the nature or concentration of the API that can be incorporated into molded troches to a certain non-thermolabile subset, which may not be practical for certain applications.

[113] As explained later in the present disclosure, the herein described superimposed revolution and rotation movements can be used to obtain a melt and disperse therein a thermolabile API at a temperature which is sufficiently low so as to limit the degradation of the thermolabile API and obtain an API-containing melt which can be molded into a troche having less than 1.0%, 0.75%, 0.5%, 0.1%, 0.05%, or 0.01% degradation products of the thermally labile API.

Superimposed revolution and rotation movements

[114] A number of devices can be used to obtain the compounded pharmaceutical composition of the present disclosure so long as the device is capable of implementing the superimposed revolution and rotation movements as described herein.

[115] In one non-limiting practical implementation, the herein described superimposed revolution and rotation movements can be performed using a planetary mixer.

[116] A planetary mixer is capable of performing the herein described superimposed revolution and rotation movements by continually and concurrently revolving and rotating a container which includes the composition ingredients. This dual action eliminates the need for mixing rods, blades or media, or an evacuation device and can dramatically reduce processing times relative to other mixing devices that use blades to mix ingredients. In one embodiment, the mixing time may be no more than 900 seconds. For example, the herein described superimposed revolution and rotation movements may be performed for less than 10, 15, 20, 25, 30, 35, 40, 45, 50, 55, 60, 75, 100, 120, 150, 180, 240, 300, 400, 500, 600, 700, 800, or 900 seconds, as well as any values included therein.

[117] Such processing time is significantly reduced when compared to the processing time required for compounding processes known in the art for compounding pharmaceutical compositions, such as the typical mortar and pestle system or devices with mixing blades, which may require an additional vacuum step to remove air entrapment in the composition. While the processing time in the superimposed revolution and rotation movements of the present disclosure is thus relatively reduced, the intensity of the processing procedure is sufficiently intense to disperse the ingredients to the point where the resulting mixture is substantially homogenous and is sufficiently gentle to prevent the internal temperature of the mixture from reaching or getting close to a degradation temperature threshold of the API.

[118] In one embodiment, the superimposed revolution and rotation movement parameters may induce a maximal G force value of at least 50 g (corresponding to approximately 1490 m/s²). In some cases, the superimposed revolution and rotation movement parameters may induce a maximal G force value of less than 500 g, or in the range of 50 g to 400 g, or 75 g to 350 g, or any suitable value within these ranges. Inducing such a maximal G force in a process by performing the herein described superimposed revolution and rotation movements can be useful for compounding

compositions which are otherwise difficult or cumbersome to compound using prior art electronic mortar and pestle system or devices with mixing blades.

[119] In one embodiment, the superimposed revolution and rotation movements are operated with operational parameters that may include revolution speeds of from at least 400 revolutions per minute (“rpm” or “RPM”). For example, a suitable revolution speed can be selected in the range of from 400 to about 4000 rpm, or from 400 to about 2000 rpm, or any suitable value within these ranges.

[120] In one embodiment, the superimposed revolution and rotation movements are operated with operational parameters that may include revolution : rotation rpm ratios of about 10:4.

[121] In certain embodiments, the revolution rpm, the rotation rpm and the mixing time are configurable parameters and their values may be individually selectable or they may be selectable from pre-determined combinations of parameter values. In other embodiments, the ratio between rotation rpm and revolution rpm may be a configurable parameter and thus would constrain the revolution rpm for a certain rotation rpm or vice versa. Moreover, the geometric configuration of the planetary mixer (e.g., the eccentricity (distance between the center of rotation and the center of revolution), the dimensions of the container, etc.), combined with the revolution rpm and rotation rpm, results in a certain acceleration (G force, measured in g or m/s^2) being felt by the material in the container. In some embodiments, the desired G force may be input to the planetary mixer, which could result in selection, by the planetary mixer, of the revolution rpm and/or the rotation rpm.

[122] In other embodiments, the minimum or maximum G force may be specified, resulting in thresholding of the rotation rpm and/or the revolution rpm, depending on the values entered. In still further embodiments, certain parameters (such as the rotation rpm or the revolution rpm) may be dynamic (i.e., vary over time) and may be input as a function of time function so as to follow a pre-determined curve. There may exist still further controllable parameters of superimposed revolution and rotation movements implemented by a planetary mixer, such as the total weight of the container being mixed.

[123] The reader will readily recognize that the herein described process offers a number of benefits to the compounding industry, in particular when this process can be integrated within a single device, namely a planetary mixer.

[124] Various implementations of the herein described superimposed revolution and rotation movements will now be described with reference to dispersing, milling, melting and de-aerating applications for compounding pharmaceutical compositions (i.e., patient personalized compositions), which can be advantageously performed in a pharmacy setting in a single device, namely a planetary mixer.

[125] While each of these applications is described in the following sections as separate variant processes, the reader will readily understand that these applications are not mutually exclusives. In other words, more than one of these applications can be performed during the same superimposed revolution and rotation movements implemented in single planetary mixer, i.e., ingredients of a patient personalized composition can be processed so as to mix and de-aerate; or so as to mix, melt and de-aerate; or so as to mix and grind; or any other combinations thereof.

Mixing Process

[126] Fig. 2 is a flow chart of a general process **100** of preparing a compounded pharmaceutical composition in accordance with an embodiment of the present disclosure.

[127] In the process **100**, the superimposed revolution and rotation movements are implemented in a planetary mixer for preparing a patient personalized composition by dispersing an API into a pharmaceutically acceptable excipient, diluent or carrier so as to obtain a substantially homogeneous patient personalized composition.

[128] At step **110**, the process includes providing the composition ingredients in a container (also referred to in this text as a “jar”) configured for containing the composition ingredients. Typically, the composition ingredients include at least one API and at least one pharmaceutically acceptable excipient, diluent or carrier.

[129] At step **120**, the process includes obtaining pre-determined or determining dispersing parameters which are required to perform a superimposed revolution and rotation movements on the composition ingredients to obtain a substantially homogeneous dispersed composition.

[130] At step **130**, the process then includes dispersing the composition using the superimposed revolution and rotation movements at least based on the pre-determined or determined dispersing parameters so as to produce the substantially homogeneous dispersed composition.

Melting process

[131] Fig. 3 is a flow chart of a process variant **100'** of preparing a compounded pharmaceutical composition in accordance with an embodiment of the present disclosure. In this variant, the process **100'** is implemented in a planetary mixer for preparing a patient personalized composition by reversibly melting pharmaceutically acceptable excipient, diluent or carrier initially in the form of solid or semi-solid particles, incorporate into the resulting melt an API, dispersing the API into the melt, and casting the melt into a desired shape, such as a troche.

[132] The variant **100'** includes at step **210**, providing pharmaceutically acceptable excipient, diluent or carrier in the form of solid or semi-solid particles in a container configured for containing the particles. Optionally, at this step, at least one API is also provided in the container.

[133] In one embodiment, the excipient, diluent or carrier in the form of solid or semi-solid particles is a polymeric material which can be reversibly melted. In a particular implementation, excipient, diluent or carrier in the form of solid or semi-solid particles is a gelatin-based material.

[134] At step **220**, the process includes obtaining pre-determined or determining dispersing parameters which are required to perform the superimposed revolution and rotation movements on the solid or semi-solid particles to obtain a more or less viscous melt.

[135] At step **230**, the process includes dispersing the solid or semi-solid particles at least based on the pre-determined or determined parameters to obtain the melt. Without being bound by any theory, it is believed that the superimposed revolution and rotation movements can melt the solid or semi-solid particles through impact of the particles against each other and/or against the container walls, thus generating kinetic energy, without requiring the addition of external heat. This process

advantageously can melt the material at a temperature which is below the T_g or T_m of the solid or semi-solid particles.

[136] In one embodiment, the at least one API is not incorporated into the container at step **210**. In such embodiment, the solid or semi-solid particles are thus melted in step **230** in the absence of an API. In such embodiment, it is thus necessary to incorporate at least one API at one point to obtain the compounded pharmaceutical composition. This is achieved with optional step **240**, in which an API is added to the melt obtained in step **230** so as to obtain an API-containing melt. In Fig. 3, step **240** is therefore labelled as being optional as it may be discarded in case at least one API was incorporated into the container at step **210** and no further API is added to the composition.

[137] At step **250**, the process includes obtaining pre-determined or determining second dispersing parameters which are required to perform second superimposed revolution and rotation movements on the API-containing melt to obtain a substantially homogeneous dispersed composition.

[138] At step **260**, the process then includes dispersing the API-containing melt at least based on the pre-determined or determined second dispersing parameters to so as to produce a substantially homogeneous dispersed composition.

[139] At step **270**, the process then includes incorporating the dispersed composition into a mold having a desired shape and causing the incorporated dispersed composition to solidify into the mold shape.

[140] This process **100** thus affords the reversible melt of pharmaceutically acceptable excipients, carriers or diluents which can be useful, for example, when making compositions which require pouring into some sort of mold to impart a shape thereto, for instance when making compounded pharmaceutical compositions in the form of troches, suppositories or throat lozenges. Advantageously, the melt can be obtained with the herein described dispersing process at temperatures below the typical molten transition temperature of the ingredients being dispersed such that it may enable the production of solid dispersion systems from thermally incompatible materials. In other words, such composition can advantageously incorporate thermally labile API which are typically not found or are found in limited concentration in troches.

[141] In the prior art, such shaped compounded pharmaceutical compositions are typically made by first thermally treating a suitable pharmaceutically acceptable excipients, carriers or diluents in solid form for a sufficient extent of time so as to obtain a melt, adding the desired API (or mixture thereof), dispersing the API into the melt to obtain a mixture, and pouring the mixture into the mold so as to obtain the desired shaped compounded pharmaceutical composition. It will be noted that, typically, API which are incorporated into such melted pharmaceutically acceptable excipients, carriers or diluents are more thermally resistant so as to be able to bear the higher temperatures involved with melting the carrier, excipient or diluent. This, in turn, can limit the nature of the API that can be incorporated into such melts or requires higher amounts of API to take into account the expected API thermal degradation.

Milling process

[142] Fig. 4 is a flow chart of a process variant **100'** of preparing a compounded pharmaceutical composition in accordance with an embodiment of the present disclosure. In this variant, the process **100'** is implemented in a planetary mixer for preparing a patient personalized composition which includes a step of reducing the particle size distribution (PSD) of at least one of the ingredients in the patient personalized composition. Reducing the PSD of one of the ingredients can be useful in reducing the gritty feeling of the resulted compounded composition, such as for example but not being limited to the case of a topical cream, ointment or gel.

[143] The process **100'** includes at step **310**, providing a container including at least one patient personalized composition ingredient such as one of an API, a pharmaceutically acceptable excipient, diluent or carrier in the form of particles where the container is configured for containing the particles.

[144] At step **320**, the process includes obtaining pre-determined or determining dispersing parameters which are required to perform superimposed revolution and rotation movements on the particles to reduce the PSD to a desired target PSD. Advantageously, the pre-determined or determined dispersing parameters are selected so as to ensure that any heat generation which could be caused during the dispersing step through the impact of particles and/or grinding media against each other and/or against the container inner walls does not reach a degradation temperature of the API.

[145] At step **330**, the process includes adding grinding media to the container. It will be apparent to the reader that steps **320** and **330** can occur in any sequence and are not limited to a serial sequence. In other words, the step **330** can occur before, during or after step **320**.

[146] At step **340**, the process includes dispersing the grinding media and the particles at least based on the pre-determined or determined parameters to reduce the PSD to the desired target PSD.

[147] At step **350**, the grinding media is separated from the dispersed composition. This can be achieved either by removing from the container, the grinding media or the dispersed composition.

[148] When step **310** does not include the addition of an API and/or when the compounding prescription recipe requires addition of an API after the dispersing step **340**, the process includes a step **360**. It will be apparent that this step is optional as the API can be incorporated at step **310**. At step **360**, an API is incorporated into the dispersed composition obtained after step **350**.

[149] At optional step **370**, the process includes obtaining pre-determined or determining second dispersing parameters which are required to perform superimposed revolution and rotation movements on the dispersed composition obtained after step **360** so as to obtain a substantially homogeneous dispersed composition.

[150] At optional step **380**, the process includes dispersing the composition using the superimposed revolution and rotation movements at least based on the pre-determined or determined second dispersing parameters so as to produce the substantially homogeneous dispersed composition.

[151] It will be apparent that in a variant, the superimposed revolution and rotation movements in presence of grinding media are performed on the API in presence of the pharmaceutically acceptable excipient, diluent or carrier.

[152] In another variant, the superimposed revolution and rotation movements in presence of grinding media are performed on the API in absence of the pharmaceutically acceptable excipient, diluent or carrier.

[153] When performing the process in presence of grinding media, the size of the particles to grind, the size of the grinding media used to grind, and the size of the resulting particles can be selected such that, for example:

$$0,004 < MS(SP)/MS(B) < 0,12$$

$$0,0025 < MS(FP)/MS(SP) < 0,25$$

[154] where MS(SP) represents the mean size diameter of the particles before grinding (starting particles), MS(FP) represents the mean size diameter of the particles after grinding (final particles), and MS(B) is the mean size diameter of the grinding beads.

[155] The grinding media may include balls (spheres) or pellets (cylinders) made of, for example, but not limited to, hardened steel, stainless steel, tungsten carbide, agate, sintered aluminium oxide, silicon nitride or zirconium oxide.

De-aerating process

[156] Fig. 5 is a flow chart of a process variant **100''** of preparing a compounded pharmaceutical composition in accordance with an embodiment of the present disclosure.

[157] In this variant, the process **100''** is implemented in a planetary mixer for preparing a patient personalized composition by dispersing an API into a pharmaceutically acceptable excipient, diluent or carrier in such manner as to minimize air entrapment into the dispersed composition or to remove any air which was present in the composition before dispersion. This can be useful in controlling the composition's specific gravity and/or reducing incorporation of air bubbles in the resulting patient personalized composition, such as for example but not limited to topical creams, ointments or gels.

[158] The process **100''** includes at step **410**, providing patient personalized composition ingredients such as an API, a pharmaceutically acceptable excipient, diluent or carrier in a container configured for receiving these ingredients.

[159] At step **420**, the process includes obtaining pre-determined or determining dispersing parameters which are required to perform superimposed revolution and rotation movements on the

personalized composition ingredients to disperse same while reducing or maintaining a target content of incorporated air in the composition.

[160] At step **430**, the process includes dispersing the ingredients using the superimposed revolution and rotation movements at least based on the pre-determined or determined parameters to disperse same while reducing or maintaining a target content of incorporated air in the composition.

Equipment and processes for industrial applicability of the invention

[161] The herein described bladeless dispersion pattern process may be performed in a single device, notably in a planetary mixer.

[162] Commercially available planetary mixers, such as the MAZERUSTAR mixer KK-300SS, KK-400W or KK-1000W from Kurabo Industries, Ltd. of Osaka, Japan or the THINKY MIXER AR-100, ARE-310, ARE-400TWIN, ARE-500, ARV-50LED, ARV-310/310LED, ARV-930-TWIN, ARV-5000, ARV-3000TWIN, and ARV-10kTWIN from Thinky Corporation of Tokyo, Japan, and the like, can be used for this purpose.

[163] A planetary mixer typically includes a jar arranged eccentrically on a so-called sun wheel, at a certain distance from the center. The jar is configured for receiving a container which contains the ingredients being processed. The planetary mixer is configured to impart a revolution movement to the sun wheel and a rotational movement to the jar, where the revolution movement is in an opposite direction to that one of the rotation such that the ingredients contained in the container are subjected to a pattern of motion throughout space, which includes superimposed revolution and rotation movements. Advantageously, this pattern of motion throughout space does not involve any blades, i.e., it is a bladeless dispersion pattern of motion throughout space. When grinding media is added to the container, the grinding media is also subjected to these superimposed movements, where the difference in speeds between the grinding media and the container produces an interaction between frictional and impact forces, which releases high dynamic energies causing size reduction of the materials in the container.

[164] In certain embodiments, the container receiving the ingredient is adapted to receive on a top end thereof, a dispensing system element such as a pump, a spray nozzle, applicator cap, and the like. It will be appreciated that the dispensing system element can further be adapted for dispensing metered doses as described, e.g., in U.S. 2014/0221945 filed February 4, 2014 and PCT/CA2016/050179, filed February 23, 2016. This implementation effectively avoids or eliminates decanting steps, thus, minimizing the risk of material loss. This implementation also reduces time required for cleaning the container after a compounding procedure, which is typically required to avoid cross-contamination risks that exist when using the same container for dispersion of various compounded pharmaceutical compositions. The reader will appreciate that when performing the milling step, the grinding media is preferably removed from the container before the latter receives the dispensing system element at the top end thereof.

[165] Such features are also advantageous to the compounding industry and are believed to address an unmet need in this industry.

[166] Fig. 6 generally shows a planetary mixing system **10** which includes a planetary mixing apparatus **100** configured to effect the herein described superimposed revolution and rotation movements through rotation and revolution of a jar **102** placed in a jar holder **104**.

[167] The system **10** includes a lid **106** that attaches onto a mouth **108** of the jar **102**. The lid **106** may be a screw-on lid as shown, or it may be a snap-on lid, for example. The jar **102** and the lid **106** may be made of high density polyethylene (HDPE) or polypropylene, for example.

[168] The jar **102** may have different interior and exterior dimensions. With reference to the elevated cross-sectional view in Fig. 1, the jar **102** may have an inside diameter **202**, **204**, **206** that changes from the top of the jar **102** to the bottom of the jar **102**. For example, the inside diameter **202** at the top of the jar **102** may be smaller than the inside diameter **206** at the bottom of the jar **102**. This gradient can be achieved in two or more sections or as a gradual taper. In the illustrated embodiment, the jar **102** has three sections **212**, **214**, **216**, with the top section **212** having the smallest inside diameter **202**, the bottom section **216** having the largest inside diameter **206** and the middle section **214** whose inside diameter **204** is somewhere in between. Example dimensions for the top, middle and bottom inside diameters, not to be considered limiting, are **65** to **70** mm, **65** to **70** mm and **65** to **70** mm, respectively. Alternatively, one can consider that the top inside diameter

202 is between 90 and 99.9 percent of the middle inside diameter **204**, and the middle inside diameter **204** is between 90 and 99.9 percent of the inside diameter **206**. Also, there are multiple height dimensions possible for the jar **102**. For example, the height dimension of the jar **102** (measure externally) could be in the range from **85 mm** to **120 mm**.

[169] The outside of the jar **102** may be configured to be received in the jar holder **104**. In particular, the jar holder **104** may include a plurality of circumferentially spaced projections **104A**. Correspondingly, and as shown with additional reference to Fig. 7, the jar **102** may, accordingly, include a plurality of circumferentially spaced notches **302** that receive the projections **104A**, so as to prevent free-spinning of the jar **102** within the jar holder **104**. As a result, rotation of the jar **102** will only occur when the jar **104** holder itself rotates. Other rotational stoppage mechanisms may be provided in different embodiments. In other embodiments, the jar **102** may be of any other suitable shape and may include an internal surface that may be smooth, rough, and/or comprise any suitable texture.

[170] Containers of various sizes for containing pharmaceutical composition exist in the market, such as (i) containers in which compounds are traditionally dispersed by an electric mortar/pestle and (ii) containers from which compounds are dispensed (such as bottles and syringes). As will be discussed later in this text, the system **10** may be configured to implement the superimposed revolution and rotation movements described here in containers / jars of various sizes.

[171] Fig. 8 shows an example container **402** in which pharmaceutical composition ingredients would traditionally be dispersed by an electric mortar/pestle. One example of the container **402** is referred to in the industry as an Unguator™ jar (available from GAKO Konietzko GmbH, Bamberg, Germany), although recently similar containers have been made available by Samix GmbH, Zella-Mehlis, Germany.

[172] The container **402** includes a body **404** and a cover **406**. The body **404** and the cover **406** may be complementarily threaded. The cover **406** includes a nozzle **408**, which may include an external thread **408A** to receive an internally threaded cap **410**. The cap **410** has an external diameter denoted **410A**. The nozzle **408** has an aperture **412** that allows fluid to escape the container **402** when the cap **410** is removed and a piston (not shown) is pushed from underneath the body **404**. For electric mortar/pestle mixing, the cap **410** is removed from the cover, the cover **406** is removed

from the body **404**, a blade shaft (not shown) is inserted from underneath the cover **406** and through the aperture **412** and connected to a motor (not shown); meanwhile, the body is filled with the composition ingredients to be dispersed, then the blade is positioned inside the body **404** and the cover **406** is secured back onto the body **404**.

[173] Fig. 9 shows alternative containers **502A**, **502B** and **502C**. The containers **502A**, **502B** and **502C** include a respective cylindrical body **504**, **504'** and **504''**, and an actuator **506**. The actuator **506** can be actuated by a user to dispense a composition contained in the body **504**. Depending on the embodiment, the actuator **506** may in fact allow metered dispensing of the composition.

[174] As is apparent from the above, the containers used for dispersing pharmaceutical composition ingredients (e.g., containers **402**, **502A**) do not necessarily correspond to the jar **102**. As such, in accordance with various embodiments, and with reference to Fig. 10B, there is provided an adapter **602** between the jar **102** and the container **600** (generally referred to by **600** but which could be one of the aforementioned containers **402**, **502A**). The container **600** has a smaller volume than the jar **102** and is secured to an interior of the jar **102** by the adapter **602**. The adapter is designed not to hold the composition but rather to secure the container **600** to the jar **102**. The ability to secure a container **600** with a smaller volume entirely within the jar **102** can allow smaller quantities of pharmaceutical composition ingredients to undergo efficient dispersing despite the small amount of the composition.

[175] In one embodiment, the jar **102** may have a volume of approximately **250** ml, while the container **600** may have a volume of approximately **100** ml, or approximately **80** ml, or approximately **50** ml, or approximately **35** ml, or approximately **30** ml, or approximately **20** ml or approximately **15** ml. It should be appreciated that a height-to-base ratio (HBR) associated with a certain quantity of a composition to be dispersed in a particular vessel may be defined as the quotient between a height dimension occupied by the quantity of the composition and a base dimension occupied by the quantity of the composition, when that quantity is placed into the particular vessel. The HBR may be a parameter indicative of how efficiently the composition will be dispersed, where more efficient dispersing could be defined as reaching the same degree of homogeneity earlier in the dispersion process, or reaching a higher degree of homogeneity at the same duration of dispersion.

[176] With continued reference to Fig. 10A, there is shown an example quantity of composition **610** placed in the jar **102** and with reference to Fig. 10B, the same quantity of composition **612** placed in the container **600** that is secured to the jar **102** by the adapter **602**. The height dimension occupied by the composition **610** in the jar **102** is given by HJ and the base dimension is given by the bottom inside diameter **206** of the jar **102**, which can be referred to as B206. Thus, the HBR associated with the quantity of composition **610** is $HJ / B206$ for the jar **102**. Turning now to the case of the container **600**, it is seen that the height dimension occupied by the composition **612** in the container **600** is given by HC and the base dimension is given by the bottom inside diameter of the container **600**, which can be referred to as BC. Thus, the HBR associated with the quantity of composition **612** is HC / BC for the container **600**.

[177] It should be apparent, therefore, that for the same quantity of pharmaceutical composition, the HBR for the container **600** is greater than for the jar **102**. In fact, the smaller the quantity of the composition, the greater the difference in HBR between the jar **102** and the container **600**. This increase in HBR from the jar **102** to the container **600** (for the same quantity of composition) is a function of the ratio between the base area of the jar and the base area of the container. For certain quantities of ingredients and certain container sizes, the HBR will fall outside a desired range (e.g., 0.75 to 1.5, or 0.75 to 1.33, or even 1 to 1.25) if the composition is placed directly in the jar **102** and will be closer to, or within, the desired range, if the composition is placed in the container **600**.

[178] Another parameter that could be indicative of how efficiently the composition will be dispersed may be “percent volume occupancy” (PVO). For a quantity of composition in a vessel with a generally cylindrical internal volume, the PVO may be defined as the ratio of the height dimension occupied by the composition to the overall interior height dimension of the vessel. In the example of Fig. 10A, the PVO for the jar **102** is clearly under 20%, whereas for the container **600** in Fig. 10B it is over 50%. It should be apparent, therefore, that for the same quantity of composition, the PVO for the container **600** is greater than for the jar **102**. In fact, the smaller the quantity of the composition, the greater the difference in PVO between the jar **102** and the container **600**.

[179] Expressed another way, the use of the container **600** with the jar **102** can allow a composition that occupies $\frac{1}{2}$ of the jar capacity to have an HBR between 0.75 and 1.5 (or between 0.75 and 1.33, or even between 1 and 1.25) when the composition is placed into the container **600**.

[180] As such, it may be more desirable to utilize a container **600** having a certain size, rather than the jar **102**, in order to process smaller quantities of composition, so as to obtain a more suitable HBR or PVO. This is especially the case when the quantity of the composition to be processed is less than half the capacity of the jar **102** or less than a quarter of the capacity of the jar or less than a tenth of the capacity of the jar.

[181] To allow the use of a smaller container with improved HBR or PVO, the adapter **602** may help reduce or prevent rattling and other instabilities within the jar **102** during processing by the apparatus **100**. The adapter **602** is disposed between the interior of the jar **102** and the exterior of the container **600**. When the adapter **602** is attached to the container **600**, it can be inserted into and removed from the jar **102**, and for this reason the container **600** together with the adapter **602** may be referred to as a removable “containing system” **606**.

[182] Different embodiments of the adapter **602** may be provided for different versions of the container **600**. Thus, depending on whether the container **600** is a compounding bottle with a nozzle (such as container **402**) or a cylindrical bottle (such as container **502A**), the adapter **602** may take on a different shape or structure. This is now described in some detail.

[183] Fig. 11 shows a non-limiting embodiment of an adapter **700** for use with a nozzled container, such as the container **402**. The adapter **700** may be in the form of a disk with an aperture **702** in the center thereof. The adapter **700** occupies an area in 3-dimensional space that is outlined by an envelope **704**. The adapter **700** may be populated with voids **706** that reduce the weight of the adapter and therefore the density of the adapter **700** vis-à-vis the envelope **704** that it occupies. In some embodiments, the voids **706** are evenly spaced circumferentially and give the adapter **700** the appearance of a wheel.

[184] In some embodiments, the adapter **700** is configured to attach to a container with a nozzle, such as the container **402** previously described. To this end, the aperture **702** has a dimensionality that is selected according to the configuration of the nozzle **408** of the container **402**. In particular,

Fig. 12 shows details of the external threads **408A** on the nozzle **408** and the adapter **700** shown in Fig. 11 may accordingly include internal threads **708** in the area of the central aperture **702** so as to enable the adapter **700** to be screwed onto the nozzle **408**. It should be appreciated that when nozzled containers of different sizes all share the same design of the nozzle **408**, the same adapter **700** may be used for these various containers.

[185] Fig. 13 shows an alternative non-limiting embodiment of an adapter **900**, also including an aperture **902**, but where the aperture **902** is made slightly wider than the aperture **702** and in fact slightly wider than the maximum diameter of the external threads **408A** of the nozzle **408**. However, the width of the aperture **902** is smaller than the external diameter **410A** of the cap **410** (shown in Fig. 8). Thus, when the adapter **900** is placed over the nozzle **408** and then the cap **410** is threaded onto the nozzle **408**, the adapter **900** ends up being enclosed between the cover **406** and the cap **410**.

[186] The adapters **700**, **900** may have a thickness of between 0.5 mm and 5 mm, or even between 1 and 3 mm, although it may be thinner in some embodiments and thicker in others. Other design considerations include (i) that there be sufficient threading **408A** in the nozzle **408** to allow the cap **410** to be securely mounted thereto and (ii) once the cap **410** is mounted to the nozzle **408** (on top of the adapters **700**, **900**) and a containing system **606** is positioned in the jar **102**, that there be sufficient clearance (the minimum being zero, i.e., flush) between the top of the cap **410** and the underside of the lid **106** of the jar **102** once the lid **106** has been mounted to the mouth **108** of the jar **102**.

[187] To mitigate lateral rattling, the containing system **606** should fit frictionally within the jar **102**. To this end, with reference to Fig. 14, the adapter **602** is seen as having a cross-sectional width **1002** that is substantially equal to the cross-sectional width **108W** of the mouth **108** of the jar **102**. When the containing system **606** is placed into the jar **102**, the maximum space between the outer edge of the adapter **602** and the inner surface **218** of the jar **102** may be less than 2 mm, in some cases less than 1 mm and in some cases less than 100 microns.

[188] It should be appreciated that although it is important that there be sufficient clearance between the top of the cap **410** (mounted to the adaptors **700**, **900**) and the underside of the lid **106** of the jar **102** once the lid **106** has been mounted to the mouth **108** of the jar **102**, excessive clearance

could allow motion along the main axis **608** of the containing system **606** during mixing by the mixing apparatus **100**. (Of course, the main axis **608** is shown as being vertical in the drawings, but in use, it is recognized that the jar **102** sits at an angle, and therefore the main axis **608** will be oblique). Excessive clearance is caused by the smaller container sizes that do not have sufficient height dimensions, such that when the adapters **700**, **900** are used, the ensuing containing system **606** would still be free to travel in a piston like fashion.

[189] With reference to Fig. 15, there is shown an alternative embodiment of an adapter **1100**, which may be useful with smaller container sizes. The adapter **1100** includes a disk **1102** and a band **1104** that surrounds and extends upwardly from the disk **1102**. The disk **1102** has a central aperture **1106** that could be similar to the aperture **702** in Fig. 11 (which is internally threaded to engage the external thread **408A** of the nozzle **408**) or to the aperture **902** in Fig. 13 (which is wider than the nozzle **408**). The band **1104** includes a ring **1108** and, optionally, a lip **1110**. The ring **1108** has an outside diameter **1112** than is substantially equal to the top inside diameter **202** of the jar **102**. The lip **1110** extends radially outwardly beyond the ring **1108**, but only slightly, as it is configured to rest on the mouth **108** of the jar **102** without protruding radially from the jar **102**. The lip **1110** therefore also has a circular shape and its maximum diameter corresponds to the outer diameter **220** of the jar body **102**. The ring **1108** therefore fits frictionally into the jar **102**, descending towards the middle section **214** of the jar **102**, while the lip **1110** acts as a stopper to prevent the ring **1108** from being pushed too deep into the jar **102**. The lid **106** may still be placed onto the mouth **108** of the jar **102**, although in reality it is being placed onto an upper surface of the lip **1110**. Thus, the height of the jar is increased by no more than 1 or 2 mm, on top of which the lid **106** is positioned.

[190] As shown in Fig. 16, the adapter **1100** may be attached to the container **402** between the top surface of the cover **406** and the bottom surface of the cap **410**. When the containing system **606** is placed in the jar **102**, a range of smaller sizes of containers **402** can be secured in place by the adapter **1100**. In particular, assuming that they all share the same nozzle **408** and cap **410** configuration, the largest size container **402** will be the one whose bottom **1114** touches the bottom of the inside of the bottom surface of the jar **102** when attached to the adapter **1100** of Figs. 15 and 16.

[191] Thus, smaller sizes of the container **402** can be accommodated by the adapter **1100**. In particular, containers having less height can be accommodated by attaching the adapter **1100** in exactly the same way. The difference is that the container will now be suspended within the jar. This is shown in the cross-sectional drawing of Fig. 17. In particular, it is seen that no direct contact exists between the container **1302** and the inner wall **218** of the jar **102**. Rather, the adapter **1100** provides the only contact with inner wall **218** of the jar **102**. However, this is not a requirement. For example, in other embodiments (not shown), the cap **410** that is threaded onto the nozzle **408** of the container **1302** may contact the underside of the lid **106** of the jar **102**. An advantage of the adapter **1100** of Figs. 15 to 17 may be that the same adapter **1100** can accommodate different size nozzled containers, for example, 50 ml, 30 ml or 20 ml, to name a few non-limiting possibilities.

[192] It should be appreciated that for certain container sizes, although the container **1302** is suspended within the jar **102** at rest by the adapter **1100**, during operation, there may be contact between the outer wall of the container **1302** and the inner wall **218** of the jar **102**. This may be caused by the high centrifugal force exerted by the apparatus **100** on the containing system **1306** (i.e., the adapter **1100** and the container **1302**, including its contents), which could temporarily deform the container **1302** and/or the adapter **1100** to a point where at least a portion surface of the container **1302** makes direct contact with the inner wall **218** of the jar **102**.

[193] In another embodiment, the container that contains the composition to be dispersed does not have a cover with a threaded nozzle. Rather, the container may be a cylindrical container with a substantially smooth and even cylindrical profile. In this case, the adapter may be configured to clamp the container from the sides.

[194] Specifically, Figs. 18A and 18B each show an embodiment of an adapter **1400** at rest, including a base **1402** and a plurality of prongs **1404** distributed circumferentially. The adapter **1400** defines a central opening **1414** into which a container such as the container **502A** may be inserted and surrounded by the prongs **1404**. The adapter **1400** has a height dimension **1406** that may correspond substantially to the inside height of the jar **102**. The prongs **1404** may be resilient and slightly outwardly biased. As such, when the adapter **1400** is at rest (outside the jar **102**, as shown in Figs. 18A and 18B), the prongs **1404** define a substantially band-like cross-section **1408** with an inside width **1410** and an outside width **1412**. The inside width **1410**, near the top of the adapter

1400, is slightly greater than an outside diameter **508** of the container **502A** for which it is configured. Thus there is a gap **1502** as shown in Fig. 19. Also, at rest, the outside width **1412**, near the top of the adapter **1400**, is slightly greater than the top inside diameter **202** of the jar **102** (see Fig. 1). As will now be explained, there is enough resiliency in the prongs **1404** so that they may be compressed radially inwardly.

[195] In particular, Fig. 20 shows a cross-sectional view of the adapter **1400** when the containing system **1600** (including the adapter **1400** and the container **502A**) is placed inside the jar **102**. Here, the prongs **1504** are compressed inwardly (towards the center) and the inside width **1410** of the band-like cross-section **1408** formed by the prongs **1404** is now substantially the same as the outside diameter **508** of the container **502A** and the outside width **1412** of the band-like cross-section formed by the prongs **1404** is now substantially the same as the top inside diameter **202** of the jar **102**. As a result, the container **502A** is more snugly maintained by the prongs **1404** within the central opening **1414**.

[196] The number of prongs **1404** is not particularly limited. The embodiment of Figs. 18A and 18B show the adapter **1400** having three prongs **1404**. However, in other embodiments, such as in Fig. 21, the adapter **1700** has four prongs **1704**.

[197] To limit the amount of material used to make the adapter **1400**, **1700**, the adapter may include cut-outs **1418**, **1718** between the prongs **1404**, **1704**. The cut-outs have a depth defined as a relative distance occupied by the cut-outs in a height dimension of the adapter compared to the overall height of the respective adapter **1400**, **1700**. For example, for the adapter **1700** for which a side elevational view is shown in Fig. 21, the depth of the cut-outs **1718** is over 50%. In other embodiments, such as for the adapter **1400** for which a side elevational view is shown in Fig. 18, the depth of the cut-outs **1418** may be over 60%, over 70% or even over 80%. In further embodiments, it may be between 40% and 50%.

[198] The cut-outs **1418**, **1718** may take on different shapes and configurations. In Figs. 18B and 21, the cut-outs **1418**, **1718** have a deep parabolic shape. In other embodiments, the cut-outs may have a more square-like (or rectangular) appearance.

[199] In certain embodiments, as shown in Fig. 19, the container **502A** may include a vertical viewing window **1504** that allows a user to see a level to which the container **502A** is filled. Accordingly, the cut-outs **1418** may be shaped so as to allow at least part of the viewing window **1504** to be unobstructed.

[200] Turning back to Fig. 18, with additional reference to Fig. 14, the base **1402** of the adapter **1400** may be circular and may have a diameter **D1402** that is substantially identical to the top inside diameter **202** of the jar **102**, or even slightly greater than it (e.g., corresponding to the middle inside diameter **204** or by up to 1 mm or even 2 mm larger). Thus, aligning the base **1402** of the adapter **1400** with the mouth **108** of the jar **102** may make it difficult or even impossible to fit the adapter **1400** into the jar **102**. Thus, a different technique for inserting the adapter **1400** into the jar **102** may be required. To this end, the base **1402** can be tilted and then placed onto the mouth **108** of the jar **102**, such that only two diametrically opposite extremities **1419**, **1420** of the base **1402** are in contact with the inner surface **218** of the jar at respective contact points **222**, **224** of the adapter **1400**. The adapter **1400** is then urged into the jar, which causes a very slight expansion of the width of the mouth **108**, while resulting in a contraction of the mouth elsewhere between the two aforementioned contact points **222**, **224**. However, since the adapter **1400** is not in contact with these contracting regions, the jar **102** is allowed to flex, and thus allows the adapter **1400** to slip into the jar **102**. Once the two contact points **222**, **224** of the adapter **1400** pass the top section **212** of the jar **102** (which has the smallest width, namely the top inside diameter **202**) and move to the middle section **214** of the jar **102** (which has the second-smallest width, namely the middle inside diameter **204**), the mouth **108** of the jar **102** returns back to its original shape, which may be circular.

[201] It should be appreciated that in the case of the container **502A**, with a cylindrical exterior shape, the actuator **506** may be provided so that the mixed composition can be dispensed to an end user without the need for transfer into a separate dispenser. Of course, the actuator **506** takes up part of the headroom available between the container **502A** and the underside of the lid **106**, thus limiting the volume of the composition that can be placed in the body **504** for mixing. Thus, it is possible to provide a container consisting primarily of the body **504** but without the actuator **506**. In this case, a temporary cap (not shown) could be fitted on the container body **504**, with the temporary cap being relatively short (a height less than that of the actuator **506**) and having a maximum width that is no wider than the body **504** of the container **502A**. After mixing, the

temporary cap may be removed, and replaced with the actuator **506**. Because the temporary cap can be designed with a smaller height dimension than the actuator **506**, higher (i.e., more voluminous) containers may be accommodated.

[202] Those ordinarily skilled in the art will appreciate that further improvements may be made to the design of the adapter. In particular, in the case where an adapter is designed that has a maximum width that is less than the width of the jar, rotational motion of the jar may induce slippage in the containing system (which includes the adapter and the container). The amount of slippage may further be a function of the dimensions of the container and the weight and/or volume of the composition contained therein. To reduce slippage, various possible anti-slippage mechanisms may be provided, depending on operational requirements.

[203] Firstly, Fig. 22 shows an adapter **2100** fitted with a rubberized exterior peripheral band **2012**. In another example, as shown in Fig. 23, the inner surface **218** of the jar **102** may be provided with an engaging element **2202** and an adapter **2200** may be provided with a complementary engaging element **2204** that engages with the engaging element **2202**. For example, one of the engaging elements **2202**, **2204** may be a slot, while the other one of the engaging elements **2202**, **2204** may be a protrusion or pin. Of course, many other forms of complementary engaging elements may be devised that inhibit rotational motion of the adapter **2200** and/or the containing system within the jar **102**.

[204] Those skilled in the art will recognize that further improvements may be made to enhance performance during the herein described bladeless dispensing pattern process. For example, in the event that the user wishes to mix a composition that gives off heat, such heat may damage the API of the composition above a certain temperature, known as the degradation temperature threshold. With additional reference to Fig. 24, it is within the scope of the present invention to delay reaching this temperature by providing a heat conductive material **2304** between the adapter **1400** (or **1700**) and the inner surface **218** of the jar **102**. The heat conductive material **2304** may serve to dissipate heat better than simply the air that would ordinarily occupy this space. In some cases, a thermally conductive foil, foam or gel may be provided, as are made available by Fischer Elektronik GmbH, Lüdenscheid, Germany.

[205] In another embodiment, rather than a thermally conductive material, it may be desirable to place a thermally insulating material **2404** between the adapter **1400** and the inner surface **218** of the jar **102**, as shown in Fig. 25. The insulating material **2404** may serve as a barrier to heat leaving the container **502A**, which will result in an increase in the temperature within the container **502A**. As a result, it may be possible to melt the compound that is undergoing the herein described bladeless dispensing pattern process within the container **502A**, thereby leading to a state change of the composition through novel use of the apparatus **100**. Moreover, the use of the heat insulating material **2404** may accelerate the melting process, i.e., shortening the time it takes to melt the composition, thus leading to a more efficient usage of the apparatus **100**.

[206] With reference to Fig. 26, there is shown an insert **2502** that may be removably positioned within the jar **102**. The insert **2502** has the form of a metallic cup with a bottom, but in other embodiments it may be a bottomless sleeve. The insert **2502** may be made of hardened steel, stainless steel, tungsten carbide, agate, sintered aluminium oxide, silicon nitride or zirconium oxide, for example. Also provided are grinding media **2504** such as balls or pellets made of similar materials, as shown in Fig. 27. In an embodiment, the insert **2502** is friction fitted to the inner surface **218** of the jar **102** and may have a thickness of between 10 and 100 mils, although other thicknesses are possible. In another embodiment, the insert **2502** may have a smaller volume and may be held in place within the jar by an adapter, which may be similar to the previously described adapters. As a result, it may be possible to grind ingredients of the compounding composition through novel use of the apparatus **100**.

Definitions

[207] Compounding activities, in the context of the present specification, also applies to combining, mixing or altering ingredients for a cosmetic composition which may include active over the counter (OTC) ingredients or prescription pharmaceutical ingredients. Within the context of the present specification, OTC and prescription ingredients are encompassed by the expression “active pharmaceuticals ingredients” (i.e., “API”).

[208] Examples of active pharmaceuticals ingredients (APIs) include, but are not limited to, antibiotics, analgesics, vaccines, anticonvulsants; antidiabetic agents, antifungal agents, antineoplastic agents, antiparkinsonian agents, anti-rheumatic agents, appetite suppressants, biological response

modifiers, cardiovascular agents, central nervous system stimulants, contraceptive agents, dietary supplements, vitamins, minerals, lipids, saccharides, metals, amino acids (and precursors), nucleic acids and precursors, contrast agents, diagnostic agents, dopamine receptor agonists, erectile dysfunction agents, fertility agents, gastrointestinal agents, hormones, immunomodulators, antihypercalcemia agents, mast cell stabilizers, muscle relaxants, nutritional agents, ophthalmic agents, osteoporosis agents, psychotherapeutic agents, parasympathomimetic agents, parasympatholytic agents, respiratory agents, sedative hypnotic agents, skin and mucous membrane agents, smoking cessation agents, steroids, sympatholytic agents, urinary tract agents, uterine relaxants, vaginal agents, vasodilator, anti-hypertensive, hyperthyroid, anti-hyperthyroid, anti-asthmatics and vertigo agents.

[208a] As known in the prior art, an API may also include compounds such as one or more cannabinoid(s), for example as described in US 9,962,341, US 9,669,002, US 9,168,278, US 2016/0361290, US 2017/0143642 and US 2017/0290869. The term “cannabinoid” is generally understood in the art to include any chemical compound that acts upon a cannabinoid receptor. For the purpose of this specification, the expression “cannabinoid” means a compound such as tetrahydrocannabinol (THC), cannabidiol (CBD), cannabigerolic acid (CBGA), cannabigerol (CBG), cannabigerol monomethylether (CBGM), cannabigerovarin (CBGV), cannabichromene (CBC), cannabichromevarin (CBCV), cannabidiol (CBD), cannabidiol monomethylether (CBDM), cannabidiol-C4 (CBD-C4), cannabidivarin (CBDV), cannabidiocol (CBD-C1), delta-9-tetrahydrocannabinol (Δ 9-THC), delta-9-tetrahydrocannabinolic acid A (THCA-A), delta-9-tetrahydrocannabinolic acid B (THCA-B), delta-9-tetrahydrocannabinolic acid-C4 (THCA-C4), delta-9-tetrahydrocannabinol-C4, delta-9-tetrahydrocannabivarin (THCV), delta-9-tetrahydrocannabiorcol (THC-C1), delta-7-cis-iso tetrahydrocannabivarin, delta-8-tetrahydrocannabinol (Δ 8-THC), cannabicyclol (CBL), cannabicyclovarin (CBLV), cannabielsoin (CBE), cannabinol (CBN), cannabinol methylether (CBNM), cannabinol-C4 (CBN-C4), cannabivarin (CBV), cannabinol-C2 (CBN-C2), cannabiorcol (CBN-C1), cannabinodiol (CBND), cannabinodivarin (CBVD), cannabitriol (CBT), 10-ethoxy-9hydroxy-delta-6a-tetrahydrocannabinol, 8,9-dihydroxy-delta-6a-tetrahydrocannabinol, cannabitriolvarin (CBTV), ethoxy-cannabitriolvarin (CBTVE), dehydrocannabifuran (DCBF), cannabifuran (CBF), cannabichromanon (CBCN), cannabicitran (CBT), 10-oxo-delta-6a-tetrahydrocannabinol (OTHC), delta-9-cis-

tetrahydrocannabinol (cis-THC), 3,4,5,6-tetrahydro-7-hydroxy-alpha-alpha-2-trimethyl-9-n-propyl-2,6-methano-2H-1-benzoxocin-5-methanol (OH-iso-HHCV), cannabiripsol (CBR), trihydroxy-delta-9-tetrahydrocannabinol (triOH-THC), cannabinol propyl variant (CBNV), and derivatives thereof.

[208b] It is also known in the art that “cannabidiol” or “CBD” are generally understood to refer to one or more of the following compounds, and, unless a particular other stereoisomer or stereoisomers are specified, includes the compound “ Δ^2 -cannabidiol.” These compounds are: (1) Δ^5 -cannabidiol (2-(6-isopropenyl-3-methyl-5-cyclohexen-1-yl)-5-pentyl-1,3-benzenediol); (2) Δ^4 -cannabidiol (2-(6-isopropenyl-3-methyl-4-cyclohexen-1-yl)-5-pentyl-1,3-benzenediol); (3) Δ^3 -cannabidiol (2-(6-isopropenyl-3-methyl-3-cyclohexen-1-yl)-5-pentyl-1,3-benzenediol); (4) $\Delta^{3,7}$ -cannabidiol (2-(6-isopropenyl-3-methylenecyclohex-1-yl)-5-pentyl-1,3-benzenediol); (5) Δ^2 -cannabidiol (2-(6-isopropenyl-3-methyl-2-cyclohexen-1-yl)-5-pentyl-1,3-benzenediol); (6) Δ^1 -cannabidiol (2-(6-isopropenyl-3-methyl-1-cyclohexen-1-yl)-5-pentyl-1,3-benzenediol); and (7) Δ^6 -cannabidiol (2-(6-isopropenyl-3-methyl-6-cyclohexen-1-yl)-5-pentyl-1,3-benzenediol).

[208c] It is also known in the art that tetrahydrocannabinol (THC) is only psychoactive in its decarboxylated state. The carboxylic acid form (THCA) is non-psychoactive. Delta-9-tetrahydrocannabinol (Δ^9 -THC) and delta-8-tetrahydrocannabinol (Δ^8 -THC) produce the effects associated with cannabis by binding to the CB1 cannabinoid receptors in the brain.

[208d] It is also known in the art that a cannabinoid may be in an acid form or a non-acid form, the latter also being referred to as the decarboxylated form since the non-acid form can be generated by decarboxylating the acid form.

[208e] It is further known in the art that MEDISCA (Canada) commercializes Gelatin Gum Base (Product No: 2779) which is an unflavored pre-blended base (gelatin, water, glycerin) that allows for easy compounding of popular oral dosage forms such as Gummies and Gelatin troches. MEDISCA’s Gelatin Gum Base can be conveniently processed into small pieces, making it easier to compound dosage forms that increase patient compliance and satisfaction.

[209] In certain embodiments, the API is a poorly water-soluble drug or a drug with a high melting point.

[210] The API may be found in the form of one or more pharmaceutically acceptable salts, esters, derivatives, analogs, prodrugs, and solvates thereof. As used herein, a “pharmaceutically acceptable salt” is understood to mean a compound formed by the interaction of an acid and a base, the hydrogen atoms of the acid being replaced by the positive ion of the base. Non limiting examples of pharmaceutically acceptable salts include sulfate, citrate, acetate, oxalate, chloride, bromide, iodide, nitrate, bisulfate, phosphate, acid phosphate, isonicotinate, lactate, salicylate, acid citrate, tartrate, oleate, tannate, pantothenate, bitartrate, ascorbate, succinate, maleate, gentisinate, fumarate, gluconate, glucuronate, saccharate, formate, benzoate, glutamate, methanesulfonate, ethanesulfonate, benzenesulfonate, p-toluenesulfonate, and pamoate. Another method for defining the ionic salts may be as an acidic functional group, such as a carboxylic acid functional group, and a pharmaceutically acceptable inorganic or organic base. Non-limiting examples of bases include, but are not limited to, hydroxides of alkali metals such as sodium, potassium and lithium; hydroxides of calcium and magnesium; hydroxides of other metals, such as aluminum and zinc; ammonia; and organic amines, such as unsubstituted or hydroxy substituted mono-, di-, or trialkylamines; dicyclohexylamine; tributylamine; pyridine; N-methyl-N-ethylamine; diethylamine; triethylamine; mono-, bis- or tris-(2-hydroxy-lower alkyl amines), such as mono- bis- or tris-(2-hydroxyethyl)amine, 2-hydroxy-tert-butylamine, or tris-(hydroxymethyl)methylamine, N,N-di-lower alkyl-N-(hydroxy

lower alkyl)-amines, such as N,N-dimethyl-N-(2-hydroxyethyl)amine, or tri-(2-hydroxyethyl)amine; N-methyl-D-glucamine; and amino acids such as arginine, lysine, and the like.

[211] The APIs may be used in a variety of application modalities, including oral delivery as tablets, capsules or suspensions; pulmonary and nasal delivery; topical delivery as emulsions, ointments or creams; transdermal delivery; and parenteral delivery as suspensions, microemulsions or depot.

[212] For the purpose of the present disclosure, the pharmaceutically acceptable excipient, diluent or carrier may be a solid, semi-solid (more or less viscous fluid) or fluid (for example a cream or an emulsion). The person of skill will appreciate that pharmaceutically acceptable excipients, diluents or carriers are known in the art and may include, but without being limited thereto, anti-adherents such as magnesium stearate; binders, such as saccharides and their derivatives (sucrose, lactose, starches, cellulose or modified cellulose, sugar alcohols such as xylitol, sorbitol or maltitol), proteins such as gelatins, synthetic polymers such as polyvinylpyrrolidone (PVP) or polyethylene glycol (PEG); coloring dyes or fragrance; glidants such as fumed silica, talc, and magnesium carbonate; hydrophilic or hydrophobic lubricants such as talc or silica, and fats, e.g. vegetable stearin, magnesium stearate or stearic acid; preservatives such as antioxidant vitamins or synthetic preservatives like parabens; sorbents or other desiccant; vehicles that serve as a medium for conveying the active ingredient such as petrolatum, gum base gelatin, dimethyl sulfoxide and mineral oil or commercial products such as VersaPro™ Gel, HRT™ Cream, OleaBase™ Plasticized, PLO Gel Mediflo™, Oral Mix™ or VersaPro™ cream, all from Medisca Pharmaceutique (Canada).

[213] For the purpose of the present disclosure, the compounding compositions of the present description may be adapted for oral, rectal, vaginal, topical, urethral, ocular, or transdermal administration.

Examples

[215] Details of specific practical implementation of the present disclosure will be further described in the following examples.

Example 1

[216] In the following experiment, a compounding composition of 150 ml including 10% progesterone dispersed in an excipient was prepared according to the herein described superimposed revolution and rotation movements. The characteristics of the resulting composition were assessed.

[217] In a dispersing container, 15 g of USP micronized progesterone (NDC: 0043-08, Lot: 56345/B) was levigated with 12.5 mL of ethoxy diglycol by hand. The container was then filled with 122.75 mL of pharmaceutically acceptable excipient VersaPro™ Cream (NDC: 2529-01, Lot: 56035D), and placed in a planetary mixer (Mazerustar KK-250S). The parameters for operating the superimposed revolution and rotation movements were set, including revolution, rotation and time variables. The resulting dispersed 10% progesterone composition was separated in the container into three layers, namely top (T), middle (M) and bottom (B) layers.

[218] The progesterone concentration of each layer was determined using high performance liquid chromatography (HPLC). The person of skill will be able to determine the HPLC assay parameters without undue effort as HPLC is a known technique. The standard deviation (SD) between the progesterone concentrations of the three layers for each prepared formulation was determined. The design of experiment (DOE) was setup as a 23 full factorial design. Explanatory operating parameters included: revolution (x1), rotation (x2) and time (x3). The response variable (y1) was defined as the standard deviation (SD) between the concentrations of progesterone from three separated layers of the prepared composition in the dispersing container. Coding of these variables with respect to mixer settings are shown in Table 1.

Table 1: Coding of Explanatory Variables

Explanatory Variables	KK-250S Mixer Setting			Coding Equation
	Low Value (-1)	Centre Point Value (0)	High Value (+1)	
Revolution, x1	1	5	9	$\frac{x1-5}{4}$
Rotation, x2	1	5	9	$\frac{x2-5}{4}$
Time, x3	1 (10 s)	7 (70 s)	15 (150 s)	$\frac{x3-8}{7}$

[219] Eight experimental runs were executed at boundary conditions and three were done at centre point values as set forth in Table 2

Table 2: Trial parameters

Randomized Trial Runs				Mixer Setting			Formulation			Mass of Samples [g]		
x1	x2	x3	Trial Run #	x1	x2	x3	Progesterone [g]	Ethoxy Diglycol [g]	VersaPro [g]	Top	Middle	Bottom
1	1	1	1	9	9	15	15.035	12.912	122.574	48.918	48.311	41.019
0	0	0	2	5	5	7	15.069	12.956	122.492	44.109	45.606	49.642
-1	-1	-1	3	1	1	1	15.037	12.895	122.009	49.097	45.395	52.768
-1	1	1	4	1	9	15	15.053	13.052	122.652	44.340	46.901	55.213
-1	-1	1	5	1	1	15	15.048	12.849	122.816	50.134	46.522	51.165
1	1	-1	6	9	9	1	15.083	12.826	122.695	50.382	50.591	45.714
0	0	0	7	5	5	7	15.030	12.744	122.454	49.940	45.959	5.454
1	-1	-1	8	9	1	1	15.012	12.778	122.784	48.311	44.961	54.641
1	-1	1	9	9	1	15	15.024	12.811	122.705	48.878	49.262	48.490
-1	1	-1	10	1	9	1	15.054	12.725	122.615	49.342	49.447	49.141

[220] Trials were randomized and the results are found in Table 3:

Table 3: Percent Progesterone and Standard Deviation Values for Each Formulation

Sample #	Percent Progesterone (w/w)	Top, Middle, Bottom layers	Average Concentration (w/w)	Standard Deviation (SD)	Relative Standard Deviation (RSD) (%)
1	9.0	T	9.3	0.351	3.77
2	9.3	M			
3	9.7	B			
4	9.7	T	9.7	0.300	3.09
5	9.4	M			
6	10.0	B			
7	1.2	T	5.9	4.392	74
8	6.6	M			
9	9.9	B			
10	8.2	T	9.5	2.166	22
11	8.3	M			
12	12.0	B			
13	3.3	T	9.4	10.078	107
14	3.8	M			
15	21.0	B			
16	9.7	T	9.5	0.346	3.64
17	9.1	M			
18	9.7	B			
19	9.8	T	9.6	0.208	2.17
20	9.7	M			
21	9.4	B			
22	1.1	T	7.8	8.997	115
23	4.2	M			
24	18.0	B			
25	7.1	T	8.8	3.659	41
26	6.3	M			
27	13.0	B			
28	4.2	T	9.1	8.545	93
29	4.2	M			
30	19.0	B			

[221] The mixing process can be modeled by the following predictive cubic regression:

SD Percent Progesterone =

$$3.886 - 1.478\left(\frac{x_1-5}{4}\right) - 1.965\left(\frac{x_2-5}{4}\right) - 0.620\left(\frac{x_3-8}{7}\right) - 1.025\left(\frac{x_1-5}{4}\right)\left(\frac{x_2-5}{4}\right) - 0.580\left(\frac{x_1-5}{4}\right)\left(\frac{x_3-8}{7}\right) - 0.840\left(\frac{x_2-5}{4}\right)\left(\frac{x_3-8}{7}\right) + 2.176\left(\frac{x_1-5}{4}\right)\left(\frac{x_2-5}{4}\right)\left(\frac{x_3-8}{7}\right) \quad \text{equa. (1)}$$

[222] In the equation (1), x_1 is the revolution setting, x_2 is the rotation setting and x_3 is the time setting.

[223] The combined effect of revolution, rotation and time was found to have the greatest effect, followed by rotation and revolution. The time setting x_3 by itself, was not statistically significant. The interaction effects were found to be relatively influential, particularly the combination effect of all three parameters. The interaction effects can be seen in Fig. 28.

[224] The model was reduced through an iterative method in order to better observe the parameter and interaction effects on a more statistically significant level. The codependency of the revolution, rotation and time was observed to have the strongest effect on the SD of progesterone concentration, followed by rotation and revolution. As expected, faster rotation and revolution speeds, decreased the SD of percent progesterone. These relationships are illustrated in Fig. 29.

[225] The reduced model can be represented by the following reduced equation:

$$SD \text{ Percent Progesterone} = 3.904 - 1.478\left(\frac{x_1-5}{4}\right) - 1.965\left(\frac{x_2-5}{4}\right) + 2.176\left(\frac{x_1-5}{4}\right)\left(\frac{x_2-5}{4}\right)\left(\frac{x_3-8}{7}\right) \quad \text{equa. (2)}$$

[226] In equation 2, x_1 is the revolution setting, x_2 is the rotation setting and x_3 is the time setting.

[227] Based on the cubic regression model (equation 1), a desirability algorithm was derived for optimization of the dispersing process. For optimal conditions, desirability was set such that SD of percent progesterone was zero and the time setting was minimized to the lowest value (i.e., 10 seconds). It was found that ideal conditions could be met given the following mixer settings: revolution = 9, rotation = 9 and time = 1. This optimization is shown in Fig. 30.

Example 2

[228] In this example, the superimposed revolution and rotation movements were performed in a planetary mixer (Mazerustar kk-300ss) in presence of grinding media. The following assays surprisingly demonstrated that the herein described superimposed revolution and rotation movements can be used to grind particles in presence of grinding media to obtain a desirable particle size distribution, while maintaining the temperature of the materials being grinded at a safe level below typical degradation temperature of thermally labile API.

[229] Briefly, the container was filled with grinding media and sodium chloride for a total volume of 32 ml, and the superimposed revolution and rotation movements were performed at 1000 rpm (revolution) and 400 rpm (rotation) for 60 seconds with either sphere grinding media of 8 mm (58 beads) or cylinder grinding media of 10 mm (37 beads). A control grinding experiment was performed using mortar and pestle of sodium chloride.

[230] A first assay was performed with 20g of sodium chloride (NDC 0629-08; lot number 602576/B, melting temperature of 801 °C). Fig. 31A shows that the sodium chloride prior to processing had the following particle size distribution (PSD) in μm : D_{10} of 225.563, D_{50} of 354.819 and D_{90} of 539.090. Fig. 31B shows that the control experiment of mortar and pestle for 60 seconds demonstrated virtually no change in the PSD, with the following values in μm : D_{10} of 171.989, D_{50} of 328.938 and D_{90} of 548.544. Fig. 31C shows that in contrast, grinding with spheres of 8 mm significantly shifted the PSD to the following lower values in μm : D_{10} of 8.476, D_{50} of 43.919 and D_{90} of 126.183, while maintaining the temperature of the mixture at a safe level below typical degradation temperature of thermally labile API. Similarly, Fig. 31D shows that grinding with cylinders also significantly shifted the PSD to the following lower values in μm : D_{10} of 11.835, D_{50} of 64.803 and D_{90} of 181.616, while maintaining the temperature of the mixture at a safe level below typical degradation temperature of thermally labile API. The results are also reported in the following Table 4:

Table 4 – Grinding of sodium chloride

	Control	Mortar and Pestle	Grinding Media (spheres)	Grinding Media (cylinders)
Surface Weighted Mean (μm)	297.087	194.680	18.511	25.690
Volume Weighted Mean (μm)	367.953	343.262	57.384	99.796
D ₁₀ (μm)	225.563	171.989	8.476	11.835
D ₅₀ (μm)	354.819	328.938	43.919	64.803
D ₉₀ (μm)	539.090	548.544	126.183	181.616
Temp. before/after ($^{\circ}\text{C}$)	24.7 / NA	24.5 / 24.1	24.7 / 39.8	25.9 / 36.9
Weight before/after (g)	5.016 / NA	20.012 / 19.989	20.027 / 19.887	20.025 / 19.908

[231] Similar results were obtained when milling 30g of sodium chloride using a mix of bead sizes, namely 80 beads were 8 mm and 25 beads were 6 mm, for a total weight of 310 g. Qualitative assessment of grinding efficacy was also performed in the planetary mixer using as starting material, granular sodium chloride at 10 g, 20 g or 30 g with 45 beads (spherical) of 8 mm filling the bottom layer of the container, for 60 sec at 1000 rpm. The results are that the various weights of materials were effectively grinded with these parameters.

[232] A second assay was performed with Gabapentin (NDC 2461-05; lot number 607832/B; melting temperature of 162 $^{\circ}\text{C}$). Fig. 32A shows that the API prior to milling had the following particle size distribution (PSD) in μm : D₁₀ of 9.688, D₅₀ of 59.399 and D₉₀ of 164.334. Fig. 32B shows that the control experiment of mortar and pestle for 60 seconds demonstrated virtually no change in the PSD, with the following values in μm : D₁₀ of 8.033, D₅₀ of 53.500 and D₉₀ of 163.239. Fig. 32C shows that in contrast, grinding with spheres for 60 seconds at 1000 rpm (revolution) and 400 rpm (rotation) significantly shifted the PSD to the following lower values in μm : D₁₀ of 1.524, D₅₀ of 9.170 and D₉₀ of 58.913, while maintaining the temperature of the mixture at a safe level below the degradation temperature of the API. Similarly, Fig. 32D shows that grinding with cylinders for 60 seconds at 1000 rpm also significantly shifted the PSD to the following lower values in μm : D₁₀ of 3.878, D₅₀ of 33.616 and D₉₀ of 150.820, while maintaining the temperature of the mixture at a safe level below the degradation temperature of the API.

The results are also reported in the following Table 4A:

Table 4A – Grinding of Gabapentin

	Control	Mortar and Pestle	Grinding Media (spheres)	Grinding Media (cylinders)
Surface Weighted Mean (μm)	21.005	18.094	3.826	10.126
Volume Weighted Mean (μm)	76.316	81.389	25.998	91.378
D ₁₀ (μm)	9.688	8.033	1.524	3.878
D ₅₀ (μm)	59.399	53.500	9.170	33.616
D ₉₀ (μm)	164.334	163.239	58.913	150.820
Temperature Before / After ($^{\circ}\text{C}$)	24.2 / NA	23.8 / 25.1	24.1 / 37.4	24.6 / 29.8
Weight Before / After (g)	2.508 / NA	10.003 / 9.797	10.011 / 9.292	10.019 / 9.599

[233] Similar results were obtained when milling 15g of Gabapentin using a mix of bead sizes, namely 80 beads were 8mm and 42 beads were 6mm, for a total weight of 310 g.

[234] Other experiments were also made with the following starting material and grinding media using higher settings, namely a revolution speed of 2000 rpm and a rotation speed of 800 rpm:

Table 4B – Grinding of various API

starting material and melting temp. ($^{\circ}\text{C}$)	grinding media	Temperature Before / After ($^{\circ}\text{C}$)	Observation
Menthol, 5g (31)	20 balls, 5 mm, spherical	24.3 / 31.5 (30 sec) 24.3 / 32.5 (60 sec)	begins to clump (30 sec) melting (60 sec)
Sodium Chloride, 5g (801)	20 balls, 5 mm, spherical	24.5 / 32.9 (30 sec) 24.5 / 48.3 (60 sec)	No visible reduction in particle size.
Sodium Chloride, 5g (801)	20 balls, 5 mm, cylindrical	24.5 / 45.1 (30 sec) 24.5 / 58.5 (60 sec)	No visible reduction in particle size.
Gabapentin, 3g (162)	20 balls, 5 mm, cylindrical	24.2 / 36.7 (30 sec) 24.2 / 46.8 (60 sec)	begins to clump (30 sec) very large clumps (60 sec)
Gabapentin, 2g (162)	25 balls, 10 mm, cylindrical	24.2 / 39.1 (30 sec)	1500 rpm / 600 rpm; Container is hot to the touch. Powder has not clumped together.

[235] Other experiments were also made with 2g of sodium chloride as starting material and grinding media using various settings to more easily visually detect particle size reduction:

Table 4C – Grinding of sodium chloride at various milling parameters

grinding media	Temperature Before / After (°C)	Observation
45 balls, 8 mm, spherical	23.4 / 28.7 (30 sec) 24.7 / 35.8 (60 sec)	1000 rpm / 400 rpm (rev./rot); Visual reduction in particle size without clumping.
45 balls, 8 mm, spherical	23.8 / 42.5 (30 sec)	1500 rpm / 600 rpm (rev./rot); Visual reduction in particle size without clumping.
25 balls, 10 mm, cylindrical	24.1 / 30.6 (30 sec) 24.2 / 39.5 (60 sec)	1000 rpm / 400 rpm (rev./rot); Visual reduction in particle size without clumping.

[236] Other experiments were also made with Gabapentin 2g as starting material and grinding media using lower settings, namely a revolution speed of 1000 rpm and a rotation speed of 400 rpm:

Table 4D – Grinding of Gabapentin

grinding media	Temperature Before / After (°C)	Observation
45 balls, 8 mm, spherical	24.2 / 30.8 (30 sec) 25.7 / 35.7 (60 sec)	Visual reduction in particle size without clumping.
25 balls, 10 mm, cylindrical	24.4 / 25.6 (30 sec) 23.6 / 25.5 (60 sec)	Visually the powder does not look as micronized compared to tests with spheres.

[237] These last results suggest that processing time parameters of 30 and 60 seconds keep temperature below 40°C, which is below the typical degradation temperature for a thermally labile API.

Example 3

[238] In this example, the following compounded pharmaceutical compositions were prepared using the herein described superimposed revolution and rotation movements using a planetary mixer (Mazerustar kk-300ss) with the following dispersion parameters: processing time of 30 sec or 60 sec (either continuously or in two intervals of 30 seconds each), and dispersion speeds of 2000 rpm revolution and 800 rpm rotation. In some cases, a dye was added to the ingredients showing that the herein described superimposed revolution and rotation movements can be used to also disperse colorant within a compounded pharmaceutical composition.

Table 5 – Ointment pharmaceutical composition

2% Mucirocin Ointment	
Ingredient (NDC, Lot)	Mupirocin (2545-03, 602996/B), Mineral Oil (0949-08, 38546/I), Medisca OleaBase Plasticized (2575-05, 601610/B)
API Melting Temperature (°C)	Mupirocin (77-78)
Specific Gravity of Base	OleaBase Plasticized (0.85)

Table 6 – Hormone replacement therapy (HRT) pharmaceutical composition (emulsion)

0.5% Estriol Vaginal Cream (Emulsion, 30ml)	
Ingredient (NDC, Lot)	Estriol (0732-03, 51222/C), Propylene Glycol (0510-08, 45008/B), VersaPro Cream (2529-08, 124989/B)
API Melting Temperature (°C)	Estriol (288)
Specific Gravity of Base	VersaPro Cream (0.97)
Temperature before / after (°C)	23.6 / 25.4 (30 sec.) 25.2 / 26.2 (30 sec., rest, 30 sec.) 25.8 / 28.0 (60 sec)

Table 7 - Hormone replacement therapy pharmaceutical composition (cream base)

Estradiol 0.5mg/ml, Estriol 2mg/ml, Progesterone 150mg/ml Cream Base	
Ingredient (NDC, Lot)	Estradiol Estriol (0732-03, 51222/C), Progesterone (0043-08, 56345/B), Propylene Glycol (0510-08, 45008/B), HRT Cream (0701-08, 46213/K /B)
API Melting Temperature (°C)	Estriol (288) Estradiol (178) Progesterone (129)
Specific Gravity of Base	VersaPro Cream (0.97)
Temperature before / after (°C)	23.5 / 29.4 (30 sec.) 29.1 / 29.7 (30 sec., rest, 30 sec.) 29.1 / 31.0 (60 sec.)

Table 8 – Hormone replacement therapy pharmaceutical composition (cream base)

Estradiol 0.5mg/ml, Estriol 2mg/ml, Progesterone 150mg/ml, HRT Cream Base	
Ingredient (NDC, Lot)	Estradiol Estriol (0732-03, 51222/C), Progesterone (0043-08, 56345/B), Propylene Glycol (0510-08, 45008/B), HRT Cream (0701-08, 46213/K /B)
API Melting Temperature (°C)	Estriol (288) Estradiol (178) Progesterone (129)
Specific Gravity of Base	HRT Cream (0.98)
Viscosity of Base	HRT Cream (370 000 cP)
Temperature before / after (°C)	23.5 / 29.4 (30 sec.) 29.1 / 29.7 (30 sec., rest, 30 sec.) 29.1 / 31.0 (60 sec.)

Table 9 – Gel composition

Ibuprofen 5%, Menthol 3% Topical Gel (Suspension, 50 g)	
Ingredient (NDC, Lot)	Ibuprofen (0299-05, 57128/A), Menthol (0521-05, 41612/B), Propylene Glycol (0510-08, 45008/B), VersaPro Gel (2636-05, 45712/P)
API Melting Temperature (°C)	Ibuprofen (76), Menthol (41-44)
Specific Gravity of Base	VersaPro Gel (1.00)
Viscosity of Base	VersaPro Gel (1,000,000 cP)
Temperature before / after (°C)	23.0 / 27.3 (30 sec.) 22.9 / 26.0 (30 sec., rest, 30 sec.) 23.1 / 29.3 (60 sec.)

Table 10 – Gel composition

Ibuprofen 5%, Menthol 3%, Medisca VersaPro Gel Base	
Ingredient (NDC, Lot)	Ibuprofen (0299-05, 57128/A), Menthol (0521-05, 41612/B), Propylene Glycol (0510-08, 45008/B), VersaPro Gel (2636-05, 45712/P)
API Melting Temperature (°C)	Ibuprofen (76), Menthol (41-44)
Specific Gravity of Base	VersaPro Gel (0.984)
Viscosity of Base	VersaPro Gel (1,000,000 cP)
Temperature before / after (°C)	23.2 / 24.8 (30 sec.) 24.8 / 25.7 (30 sec., rest, 30 sec.) 25.6 / 28.4 (60 sec.)

Table 11 – Pain pharmaceutical composition

Gabapentin 6%, Ketoprofen 5%, Diclofenac 3%, Pentylene Glycol 3%, Ethoxy Diglycol 3%, Medisca VersaPro Cream Base.	
Ingredient (NDC, Lot)	Gabapentin (2461-05, 57807/I), Ketoprofen (0078-05, 56561/B), Diclofenac (2552-08, 44843/B), Pentylene Glycol (2752-08, 50713/A), Ethoxy Diglycol (1903-05, 54500/B), VersaPro Cream (2529-08, 124989/B) Red dye
API Melting Temperature (°C)	Gabapentin (162-166) Ketoprofen (94) Diclofenac (283-285)
Specific Gravity of Base	VersaPro Cream (0.99)
Temperature before / after (°C)	23.3 / 24.9 (30 sec.) 24.7 / 25.5 (30 sec., rest, 30 sec.) 25.4 / 26.6 (60 sec.)

[239] In the particular pain pharmaceutical composition described in Table 11, the red dye was added on top of the ingredients. Following the dispersion of the ingredients, the resulting mixture had a substantially homogeneous pink color as early as 30 sec.

Table 12 – Amlodipine Suspension

Amlodipine 1 mg/mL, Medisca Oral Mix	
Ingredient (NDC, Lot)	Amlodipine (2734-blk, 49214, 04/2018), Medisca Oral Mix (2512-08, I102/A, 09/2015) Red dye
API Melting Temperature (°C)	Amlodipine (178-179)
Specific Gravity of Base	Oral Mix (1.1202)
Viscosity of Base	Oral Mix (300 cP)
Temperature before / after (°C)	15.8 / 16.0 (30 sec.) 16.0 / 16.2 (30 sec., rest, 30 sec.) 16.2 / 17.0 (60 sec.)

[240] In this particular example of a pharmaceutical suspension being dispersed in presence of a red dye, the dye was placed on top of the ingredients. Following the dispersion of the ingredients, the resulting mixture had a substantially homogeneous pink color as early as 30 sec.

Example 4

[241] In this example, the following compounded pharmaceutical compositions were prepared using the herein described superimposed revolution and rotation movements in a planetary mixer (Mazerustar kk-300ss). The dispersing time and the dispersing speed parameters were modified, and a dispersing assessment was made, as indicated in the following tables. Note that the rotation speed (rpm) was kept at a value of 40% of the revolution speed (rpm).

Table 13 - Cellulose, NF (Microcrystalline)

Ingredient (NDC, Lot)	Cellulose, NF (0567-08, 27688/B)			
Weight (g)	50		25	
Temperature before / after (°C) when room temperature at 24°C	29.3 (1000 rpm/120 sec) 35.3 (1500 rpm/120 sec) 31.4 (1500 rpm/60 sec)		33.0 (1500 rpm/60 sec) 30.4 (1500 rpm/30 sec)	
Mixing assessment	1000 rpm/120 sec	+	1500 rpm/60 sec	++
	1500 rpm/120 sec	+	1500 rpm/30 sec	++

Table 14 – Lactose, NF (Monohydrate) at variable dispersing time

Ingredient (NDC, Lot)		Lactose, NF (Monohydrate) (0315-08, 600938/C and 603118/B)	
Weight (g)		50	
Revolution (rpm)	Dispersing time (sec)	Temperature after (°C) when room temperature at 24°C	Mixing assessment
1000	150	29.7	++
1000	120	29.4	++
1000	90	28.0	++
1000	60	28.0	++
500	30	25.2	+
1000	30	26.7	++
1500	30	30.9	++
2000	30	40.5	++

Table 15 – Lactose, NF (Monohydrate) at 180 sec dispersing time

Ingredient (NDC, Lot)		Lactose, NF (Monohydrate) (0315-08, 600938/C and 603118/B) Red dye	
Dispersing time (sec)		180	
Weight (g)	Revolution (rpm)	Temperature after (°C) when room temperature at 24°C	Mixing assessment
25	500	24.6	-
	1000	29.6	++
	1500	38.1	++
	2000	51.5	++
50	500	26.7	-
	1000	32.1	++
	1500	43.8	++
	2000	63.2	++
60	500	*	-
	1000	31.1	-
	1500	44.0	++
	2000	**	
75	500	*	
	1000	27.9	++
	1500	37.2	++
	2000	55.5	++

[242] In the above results, * means that the G forces were observed as being insufficient to achieve a mix whereas ** means that the temperature exceeded the pre-determined threshold temperature of 45°C for thermally labile API. In this example, a red dye was used to qualitatively assess the dispersion.

Table 16 – Capsublend at 60 sec dispersing time

Ingredient (NDC, Lot)			Capsublend-P (2594-08, 58203/C) Capsublend-S (2593-05, 51997/B and 38893/B) Red dye	
Dispersing time (sec)			60	
Weight (g)	Revolution (rpm)	Rotation (rpm)	Temperature after (°C) when room temperature at 24°C	Mixing assessment
25	400	160	25.0	-
	1000	400	27.5	-
	1500	600	31.1	-
	2000	800	37.5	++
50	400	160	25.1	-
	1000	400	27.9	-
	1500	600	32.4	-
	2000	800	41.9	++

Example 5

[243] In this example, the following compounded pharmaceutical compositions including 3 different APIs were prepared using the herein described superimposed revolution and rotation movements, or using an Unguator™ as control comparative blade mixing device (Gako International), with the following ingredients:

Table 17 – Ingredients

	%	g / ml	NDC	Lot
Diclofenac Sodium	3.0	7.5, 7.95, 7.8	2705-05	44843/B
Gabapentin	6.0	15, 15.9, 15.6		603948/A
Ketoprofen	5.0	12.5, 13.25, 13		602182/F
Pentylene Glycol	3.0	7.5, 6.5, 6.25	2752-08	507131/A
Ethoxy Diglycol	3.0	7.5, 6.5, 6.25		54500/B
VersaPro Cream Base	QS to 250 g	188.5, 265, 260		605062/A

[244] The superimposed revolution and rotation movements parameters were: 2000 rpm for 30 sec (samples 1-3). The parameters for the Unguator™ control comparative blade mixing device (samples 4-5) were: speed 5 for 120 sec (sandwich protocol). Each of the resulting composition was then separated in top, middle and bottom layers and the concentration of each API in each layer was measured with HPLC. The average concentration ([]), the standard deviation (SD) and the relative

standard deviation (%RSD) were calculated for each API. The results are shown in the following Table:

Table 17A – Results for a composition including 3 API

Assay	Diclofenac 3%			Gabapentin 6%			Ketoprofen 5%		
	[]	SD	%RSD	[]	SD	%RSD	[]	SD	%RSD
1	2.8	0.000	0.0%	5.9	0.047	0.8%	4.9	0.125	2.5%
2	2.8	0.047	1.7%	5.8	0.000	0.0%	4.9	0.082	1.7%
3	2.7	0.000	0.0%	5.7	0.000	0.0%	4.8	0.047	1.0%
4	2.8	0.125	4.4%	5.6	0.262	4.7%	4.9	0.283	5.8%
5	2.7	0.094	3.5%	5.4	0.262	4.8%	4.7	0.216	4.6%
6	2.8	0.082	2.9%	5.5	0.170	3.1%	4.8	0.094	2.0%

[245] These results show that the average %RSD is significantly lower when using the superimposed revolution and rotation movements relative to the Unguator™ control comparative blade mixing device. The inventors were also able to consistently (in over 80% of the cases) obtain for a given API less than 3% RSD, suggesting a significant homogeneity in the compositions made as well as more reproducible results (i.e., less variations from one composition to another). In contrast, the Unguator™ control comparative blade mixing device consistently (in over 80% of the cases) showed higher and variable %RSD for a given API, suggesting less homogeneous compositions and less reproducible results.

Example 6

[246] In this example, the following compounded pharmaceutical compositions including 4 different APIs were prepared using the herein described superimposed revolution and rotation movements, with the following ingredients:

Table 18 – Ingredients

Ingredients	%	g / ml	NDC	Lot
Baclofen, USP	2.0	4.0	0388-04	112624/E
Bupivacaine HCl, USP	2.5	5.0	0524-04	122720/I
Cyclobenzaprine HCl, USP	6.0	12.0	0395-05	115114/E
Diclofenac Sodium, USP	10.0	20.0	2705-05	118032/I

Ethoxy Diglycol	3.5	7.0	1903-05	119825/D
Pentylene Glycol	3.5	7.0	2752-08	122018/B
VersaPro Cream Base	72.5	145.0	2529-08	121176/D

[247] The superimposed revolution and rotation movements parameters were: 2000 rpm for 30 sec (samples 4-6). The parameters for the Unguator™ control comparative blade mixing device (samples 1-3) were: speed 5 for 120 sec (sandwich protocol). Each of the resulting composition was then separated in top, middle and bottom layers and the concentration of each API in each layer was measured with HPLC. The average concentration ([]), the standard deviation (SD) and the relative standard deviation (%RSD) were calculated for each API. The results are shown in the following Table:

Table 19 – Results for a composition including 4 API

Assay	Baclofen, 2%			Bupivacaine, 2.5%			Cyclobenzaprine, 6%			Diclofenac, 10%		
	[]	SD	%RSD	[]	SD	%RSD	[]	SD	%RSD	[]	SD	%RSD
1	2.0	0.265	13%	2.1	0.265	13%	5.4	0.586	11%	9.5	1.079	11%
2	2.0	0.058	3%	2.1	0.100	5%	5.3	0.208	4%	9.3	0.361	4%
3	1.9	0.306	16%	2.0	0.306	15%	5.1	0.794	16%	9.1	1.401	15%
4	2.1	0.058	3%	2.2	0.058	3%	5.6	0.208	4%	9.9	0.321	3%
5	2.1	0.100	5%	2.2	0.115	5%	5.5	0.306	6%	9.6	0.586	6%
6	1.9	0.000	0%	2.1	0.000	0%	5.2	0.153	3%	9.1	0.153	2%

[248] These results show that the average %RSD is significantly lower when using the superimposed revolution and rotation movements relative to the Unguator™ control comparative blade mixing device. The inventors were also able to consistently (in over 80% of the cases) obtain for a given API less than 3% RSD, suggesting a significant homogeneity in the compositions made as well as more reproducible results (i.e., less variations from one composition to another). In contrast, the Unguator™ control comparative blade mixing device consistently (in over 80% of the cases) showed higher and variable %RSD for a given API, suggesting less homogeneous compositions and less reproducible results.

Example 7

[249] In this example, a jar container having a certain internal ratio was used to disperse ingredients using the herein described superimposed revolution and rotation movements. The jar is equipped with an adaptor to fit the jar container into a receiving basket of a planetary mixer. The ingredients used a pharmaceutically acceptable carrier, excipient or diluent, Versapro Cream Base and a red dye, as a tracer. The amount of Versapro added into the container was sufficient to reach the top of the viewing window on the jar container (MD line of containers, from Medisca Pharmaceutique). Note that the rotation speed (rpm) was kept at a value of 40% of the revolution speed (rpm).

Table 20 – Results for Versapro Cream in MD jar container

Volume of Versapro Cream Base	Revolution (rpm)	Temperature (°C), Time	Observation
30 ml	400	23.3 (30 sec)	Dye reached halfway down (30 sec)
		23.7 (60 sec)	Dye moved 5mm further (60 sec)
		24.0 (90 sec)	Dye moved 2mm further (90 sec)
		24.3 (120 sec)	Dye 2mm from bottom. (120 sec)
1000	24.7 (30 sec)	25.2 (120 sec)	Dye reached the bottom, homogeneous mix (30 and 120 sec)
		25.9 (120 sec)	Dye reached the bottom, homogeneous mix
		24.0 (30 sec)	Dye reached the bottom, homogeneous mix (30 and 120 sec)
50 ml	2000	26.5 (120 sec)	
		23.7 (120 sec)	
		24.0 (30 sec)	Dye reached the bottom, homogeneous mix (30 and 120 sec)
		25.7 (120 sec)	
1500	23.9 (30 sec)	25.7 (120 sec)	Dye reached the bottom, homogeneous mix (30 and 120 sec)
		23.9 (30 sec)	Dye reached the bottom, homogeneous mix (30 and 120 sec)
		25.7 (120 sec)	
80 ml	400	23.6 (120 sec)	Slight leakage past the piston at all tested times, except for 120 sec where it is severe leakage
		23.8 (30 sec)	Dye reached the bottom, homogeneous mix
1000	24.6 (120 sec)	23.8 (30 sec)	Dye reached the bottom, homogeneous mix
		24.6 (120 sec)	

	1500	23.9 (30 sec) 25.8 (120 sec)	Dye reached the bottom, homogeneous mix
	2000	27.2 (120 sec)	Dye reached the bottom, homogeneous mix

[250] Safe dispersing parameters so as to avoid leakage, thus, appear to be 1500 rpm at 0.5 min, and are applicable to all sizes of the MD line of jar containers.

Example 8

[251] In this example, a 6.5 ml syringe container (Medisca Pharmaceutique) was used to disperse ingredients using the herein described superimposed revolution and rotation movements. The syringe container is equipped with an adaptor to fit the syringe container into a receiving basket of the planetary mixer. The ingredients used were a pharmaceutically acceptable carrier, excipient or diluent, Versapro Cream Base and a red dye, as a tracer. The amount of Versapro added into the syringe container was of 6.5g. The dispersed cream was then visually assessed for entrapped air bubbles levels and red dye homogeneity dispersion. Note that the rotation speed (rpm) was kept at a value of 40% of the revolution speed (rpm).

Table 21- Results for Versapro Cream in syringe container

Revolution (rpm)	Time (sec)	Observation
500	120	Dye failed to travel down. No noticeable change in air bubble size or shape.
1000	120	Dye failed to travel down. Air bubbles size has decreased but still large number of bubbles visible (mostly non-uniform in size and shape).
1500	30	Dye moved down 2 cm. Air bubbles size has decreased and shape of air bubbles is more uniform.
	60	Dye moved down a further 0.5 cm. Layers of colour near the center suggesting heterogeneous mixing.
	90	Dye moved down a further 0.5 cm. Layers of colour near the center suggesting heterogeneous mixing.
	120	Dye stopped at center cartridge. Heterogeneous mix
2000	30	Dye moved down effectively (2.7 cm). Fewer air bubbles, size has also decreased. Less bubble towards the top.
	60	Dye moved down an additional 1-1.5 cm. Mixing flow visible. Layers of distinct shades of pink indicate non-uniform mixing near the center.

		Slightly more uniform bubble size and shape. No significant change in number of bubbles. Temperature: 28.5°C
	90	Dye moved down (1 cm above the bottom of the cartridge). Mixing flow visible. Top layer (darker pink) has increased, more uniform in the middle compared to before, however, layers still visible. No significant Change in size, shape or number of bubbles. Temperature: 29.7°C
	120	Dye has reached bottom of cartridge completely. Mixing flow visible. Layers are less prevalent, color is more uniform throughout. Noticeable change in number of bubbles. Size has slightly decreased. Temp: 31.2°C

[252] Similar results were obtained when dispersing in a syringe container of 5.0 ml (Medisca Pharmaceutique, Montreal, Canada).

Example 9

[253] In this example, various pharmaceutically acceptable excipients, carriers or diluents in solid or semi-solid form (i.e., more or less viscous, so long as it cannot be poured like a liquid) were submitted to the herein described superimposed revolution and rotation movements in an attempt to obtain a reversible melt. The dispersing parameters used were 2000 rpm revolution and 800 rpm rotation.

Table 22 – Melting of excipient, carrier or diluent

Excipient, carrier or diluent	Observation
VersaPro™ Cream	300 sec dispersing resulted in a temperature of 31.6°C, appears as a cream
OleaBase™ Plastisized	240 sec dispersing resulted in a temperature of 38.2°C
Ointment Base	300 sec dispersing resulted in a temperature of 34.2°C, the base became very soft and liquid. There is a major change in consistency and texture.
PLO Gel Mediflo™ 30	210 sec dispersing resulted in a temperature of 39.1°C, the gel appears like a cream, not a pourable liquid
PolyPeg Suppository Base	300 sec dispersing resulted in a temperature of 51.1°C, the base appears like a cream, not a pourable liquid
SPG Supposi-Base™	300 sec dispersing resulted in a temperature of 34.1°C, the base appears like a cream, not a pourable liquid
Gum Base Gelatin	180 sec dispersing resulted in a temperature of 55.1°C, the initial cube shaped gelatin forms melt into a pourable liquid.

[254] The experiment was repeated in different planetary mixer devices, as per the following paragraphs.

Table 22.1 - Mazerustar KK-300SS comparison of gelatin gum base chunk size

	Test 10	Test 16
Lot Number	617221/A	617221/A
Mass (gram)	50.02	50.07
RPM	2000	2000
G Force	284	284
Time (seconds)	180	180
Temperature Before (°C)	23.8	25.5
Temperature After (°C)	59.6	57.7
ΔT (°C)	35.8	32.2
Observation	fully melted	not fully melted as little blocks cut stuck to the top

[255] Fig. 33 shows a typical gum base gelatin particle unaltered from the manufacturers' container (left) and a plurality of these particles contained in the dispersion jar (right). The block has a maximal extent size of about 1 inch.

[256] Fig. 34 shows gum base gelatin particles which have been cut down from the initial size present in the manufacturers' container (left) and a plurality of these particles contained in the dispersion jar (right). The cut down particles have a size of less than about 0.5 inch.

[257] A two (2) decimal place balance was used to weigh the gelatin gum base. During the weighing operations, a plastic jar was placed on the balance and tared. During the first experiment run, 50 grams was processed unaltered. During the second experiment run, the 50 grams of gelatin gum base was minced into smaller pieces. The initial temperature was recorded using a digital thermometer with stainless steel probe by inserting the tip inside of the gum base gelatin before being inserted inside the planetary mixer. The final temperature was measured once the dispersion process was completed, by inserting and swirling the stainless steel probe in the gelatin in order to avoid coagulation as much as possible.

[258] The herein described superimposed revolution and rotation movements was used to melt the gelatin gum base and the process parameters / results obtained were compared to those performed / obtained when using a hot plate. The melted gelatin gum base was assessed by measuring the

temperature before and after the melting process by using a digital thermometer with a stainless-steel probe. Fig. 35A-35E shows examples of gum base that completely melted (35A), partially melted (35B, 35C and 35D), and did not melt (35E).

Table 22.2 - Mazerustar KK-300SS – 25 gram, 180 seconds, variable G Force

	Test 3	Test 2	Test 4
Lot Number	617221/A	617221/A	617221/A
Mass (gram)	25.00	25.20	25.03
RPM	1600	1800	2000
G Force	182	230	284
Time (seconds)	180	180	180
Temperature Before (°C)	24.3	24.3	24.3
Temperature After (°C)	50.5	49.1	51.6
ΔT (°C)	26.2	24.8	27.3
Observation	partially melted	completely melted	completely melted

Table 22.3 - Mazerustar KK-300SS – 50 gram, 180 seconds, variable G Force

	Test 7	Test 9	Test 10
Lot Number	617221/A	617221/A	617221/A
Mass (gram)	50.04	50.01	50.02
RPM	1600	1800	2000
G Force	182	230	284
Time (seconds)	180	180	180
Temperature Before (°C)	24.3	24.0	23.8
Temperature After (°C)	50.7	56.1	59.6
ΔT (°C)	26.4	32.1	35.8
Observation	partially melted	completely melted	completely melted

Table 22.4 - Mazerustar KK-300SS – 75 gram, 180 seconds, variable G Force

	Test 8	Test 11	Test 12
Lot Number	617221/A	617221/A	617221/A
Mass (gram)	75.03	75.03	75.03
RPM	1600	1800	2000
G Force	182	230	284
Time (seconds)	180	180	180
Temperature Before (°C)	23.6	23.4	23.3
Temperature After (°C)	30.6	30.3	56.4
ΔT (°C)	7.0	6.9	33.1
Observation	not melted	not melted	completely melted

Table 22.5 - Mazerustar KK-300SS – 75 gram, constant G Force, variable time

	Test 12	Test 18	Test 17
Lot Number	617221/A	617221/A	617221/A
Mass (gram)	75.03	75.01	75.00
RPM	2000	2000	2000
G Force	284	284	284
Time (seconds)	180	300	450
Temperature Before (°C)	23.3	25	23.7
Temperature After (°C)	56.4	60.9	61.9
ΔT (°C)	33.1	35.9	38.2
Observation	completely melted	completely melted	completely melted

Table 22.6 - Mazerustar KK-300SS – Constant G Force, 180 seconds, variable mass

	Test 4	Test 10	Test 12
Lot Number	617221/A	617221/A	617221/A
Mass (gram)	25.03	50.02	75.03
RPM	2000	2000	2000
G Force	284	284	284
Time (seconds)	180	180	180
Temperature Before (°C)	24.3	23.8	23.3
Temperature After (°C)	51.6	59.6	56.4
ΔT (°C)	27.3	35.8	33.1
Observation	completely melted	completely melted	completely melted

Table 22.7 - Mazerustar KK-300SS – Constant G Force, 300 seconds, variable mass

	Test 20	Test 19	Test 18	Test 13
Lot Number	617221/A	617221/A	617221/A	617221/A
Mass (gram)	25.04	50.03	75.01	100.03
RPM	2000	2000	2000	2000
G Force	284	284	284	284
Time (seconds)	300	300	300	300
Temp. Before (°C)	24.3	24.1	25	23.4
Temp. After (°C)	54.2	60.4	60.9	60.1
ΔT (°C)	29.9	36.3	35.9	36.7
Observation	completely melted	completely melted	completely melted	completely melted

Table 22.8 - Mazerustar KK-400 – 75 gram, Constant time, variable G Force

	Test 14	Test 13	Test 12
Lot Number	617221/A	617221/A	617221/A
Mass (gram)	75.02	75.02	75.03
Revolution Setting #	7	8	9
Rotation Setting #	7	8	9
RPM	1058	1218	1340
G Force	170	226	273
Time (seconds)	450	450	450
Temperature Before (°C)	24.5	24.5	24.3
Temperature After (°C)	34.5	63.8	66.3
ΔT (°C)	10.0	39.3	42.0
Observation	not melted	completely melted	completely melted

Table 22.9 - Mazerustar KK-400 – 25 gram, Constant G Force, variable time

	Test 18	Test 3	Test 5	Test 1
Lot Number	617221/A	617221/A	617221/A	617221/A
Mass (gram)	25.00	25.00	25.05	25.00
Revolution Setting #	9	9	9	9
Rotation Setting #	9	9	9	9
RPM	1340	1340	1340	1340
G Force	273	273	273	273
Time (seconds)	180	300	450	600
Temp. Before (°C)	23.5	24.4	24.7	24.3
Temp. After (°C)	32.2	32.6	56.3	61.8
ΔT (°C)	8.7	8.2	31.6	37.5
Observation	not melted	not melted	completely melted	completely melted

Table 22.10 - Mazerustar KK-400 – 50 gram, Constant G Force, variable time

	Test 19	Test 2	Test 8	Test 11
Lot Number	617221/A	617221/A	617221/A	617221/A
Mass (gram)	50.06	50.00	50.04	50.01
Revolution Setting #	9	9	9	9
Rotation Setting #	9	9	9	9
RPM	1340	1340	1340	1340
G Force	273	273	273	273
Time (seconds)	180	300	450	600
Temp. Before (°C)	24.0	24.3	23.9	24.5
Temp. After (°C)	39.9	44.8	64.2	67.5
ΔT (°C)	15.9	20.5	40.3	43.0
Observation	partially melted	partially melted	completely melted	completely melted

Table 22.11 - Mazerustar KK-400 – 75 gram, Constant G Force, variable time

	Test 10	Test 6	Test 12	Test 15
Lot Number	617221/A	617221/A	617221/A	617221/A
Mass (gram)	75.06	75.01	75.03	75.02
Revol. Setting #	9	9	9	9
Rotation Setting #	9	9	9	9
RPM	1340	1340	1340	1340
G Force	273	273	273	273
Time (seconds)	180	300	450	600
Temp. Before (°C)	23.6	25.2	24.3	24.4
Temp. After (°C)	33.5	65.6	66.3	69.5
ΔT (°C)	9.9	40.4	42.0	45.1
Observation	not melted	completely melted	completely melted	completely melted

Table 22.12 - Mazerustar KK-400 – 100 gram, Constant G Force, variable time

	Test 22	Test 16	Test 20
Lot Number	617221/A	617221/A	617221/A
Mass (gram)	100.09	100.02	100.00
Revolution Setting #	9	9	9
Rotation Setting #	9	9	9
RPM	1340	1340	1340
G Force	273	273	273
Time (seconds)	300	450	600
Temperature Before (°C)	23.4	25.0	23.6
Temperature After (°C)	65.0	69.6	68.7
ΔT (°C)	41.6	44.6	45.1
Observation	completely melted	completely melted	completely melted

Table 22.13 - Mazerustar KK-400 – Constant G Force, 180 seconds, variable mass

	Test 18	Test 19	Test 10
Lot Number	617221/A	617221/A	617221/A
Mass (gram)	25.00	50.06	75.06
Revolution Setting #	9	9	9
Rotation Setting #	9	9	9
RPM	1340	1340	1340
G Force	273	273	273
Time (seconds)	180	180	180
Temperature Before (°C)	23.5	24.0	23.6
Temperature After (°C)	32.2	39.9	33.5
ΔT (°C)	8.7	15.9	9.9
Observation	not melted	partially melted	not melted

Table 22.14 - Mazerustar KK-400 – Constant G Force, 300 seconds, variable mass

	Test 3	Test 2	Test 6	Test 22
Lot Number	617221/A	617221/A	617221/A	617221/A
Mass (gram)	25.00	50.00	75.01	100.09
Revolution Setting #	9	9	9	9
Rotation Setting #	9	9	9	9
RPM	1340	1340	1340	1340
G Force	273	273	273	273
Time (seconds)	300	300	300	300
Temp. Before (°C)	24.4	24.3	25.2	23.4
Temp. After (°C)	32.6	44.8	65.6	65
ΔT (°C)	8.2	20.5	40.4	41.6
Observation	not melted	partially melted	completely melted	completely melted

Table 22.15 - Mazerustar KK-400 – Constant G Force, 450 seconds, variable mass

	Test 5	Test 8	Test 12	Test 16
Lot Number	617221/A	617221/A	617221/A	617221/A
Mass (gram)	25.05	50.04	75.03	100.02
Revolution Setting #	9	9	9	9
Rotation Setting #	9	9	9	9
RPM	1340	1340	1340	1340
G Force	273	273	273	273
Time (seconds)	450	450	450	450
Temp. Before (°C)	24.7	23.9	24.3	25.0
Temp. After (°C)	56.3	64.2	66.3	69.6
ΔT (°C)	31.6	40.3	42	44.6
Observation	completely melted	completely melted	completely melted	completely melted

Table 22.16 - Mazerustar KK-400 – Constant G Force, 600 seconds, variable mass

	Test 1	Test 11	Test 15	Test 20	Test 17
Lot Number	617221/A	617221/A	617221/A	617221/A	617221/A
Mass (gram)	25.00	50.01	75.02	100.00	151.03
Revolution Setting #	9	9	9	9	9
Rotation Setting #	9	9	9	9	9
RPM	1340	1340	1340	1340	1340
G Force	273	273	273	273	273
Time (seconds)	600	600	600	600	600
Temperature Before (°C)	24.3	24.5	24.4	23.6	23.4
Temperature After (°C)	61.8	67.5	69.5	68.7	67.5
ΔT (°C)	37.5	43	45.1	45.1	44.1
Observation	completely melted	completely melted	completely melted	completely melted	completely melted

Table 22.17 - Mazerustar KK-1000 – 200 grams, 450 seconds, variable G Force

	Test 7	Test 6	Test 2
Lot Number	608721/A & 605082/A	608721/A	617221/A
Mass (gram)	200.01	200.02	200.07
Revolution Setting #	7	8	9
Rotation Setting #	7	8	9
RPM	770	860	950
G Force	149	186	227
Time (seconds)	450	450	450
Temperature Before (°C)	23.2	22.8	24.9
Temperature After (°C)	57.5	60.6	68
ΔT (°C)	34.3	37.8	43.1
Observation	completely melted	completely melted	completely melted

Table 22.18 - Mazerustar KK-1000– 200 grams, Constant G Force, variable time

	Test 9	Test 4	Test 2	Test 5
Lot Number	605082/A	617221/A	617221/A	617221/A
Mass (gram)	200.15	200.20	200.07	200.05
Revolution Setting #	9	9	9	9
Rotation Setting #	9	9	9	9
RPM	950	950	950	950
G Force	227	227	227	227
Time (seconds)	180	300	450	600
Temperature Before (°C)	23.0	24.5	24.9	24.9
Temperature After (°C)	63.6	63.8	68.0	72.8
ΔT (°C)	40.6	39.3	43.1	47.9
Observation	completely melted	completely melted	completely melted	completely melted

Table 22.19 - Mazerustar KK-1000– Constant G Force, 450 seconds, variable mass

	Test 1	Test 2	Test 3	Test 8
Lot Number	617221/A	617221/A	617221/A	608721/A
Mass (gram)	100.05	200.07	300.09	525.53
Revolution Setting #	9	9	9	9
Rotation Setting #	9	9	9	9
RPM	950	950	950	950
G Force	227	227	227	227
Time (seconds)	450	450	450	450
Temperature Before (°C)	24.9	24.9	24.7	23.4
Temperature After (°C)	33.0	68.0	71.2	67.7
ΔT (°C)	8.1	43.1	46.5	44.3
Observation	not melted	completely melted	completely melted	completely melted

Hot plate

Table 22.20 Hot Plate

	Test 1	Test 2	Test 3
Lot Number	10810/B	10810/B	608721/A
Mass (gram)	50.325	70.273	100.090
Time (seconds)	559	790	1059
Temperature Before (°C)	24.5	24.5	24.5
Temperature After (°C)	59.1	59.6	58.4
ΔT (°C)	34.6	35.1	33.9
Observation	completely melted	completely melted	completely melted

Material and methods

Hot Plate

[259] A water bath was set with a water temperature of 65°C. A hot plate Thermos Scientific Cimarec™ model SP131325 was used. A beaker of size Pyrex™ number 1003 with capacity 1000 ml, 4 in diameter and 6 in in height, was used to contain the water. A beaker of size Veegee™ Glassco number 20229 with capacity 600 ml, 3.5 in diameter and 5 in in height, was used to contain the gelatin. The gelatin gum base was placed in the melting beaker and the timer was started. The water temperature of 65°C was maintained while briefly mixing every 3 minutes. Time was recorded once all gelatin cubes had melted. Final temperature of melted gelatin gum base was recorded. This experimental assessment was reproduced for 50, 75 and 100 grams.

Mazerustar KK-300SS, KK-400 and KK-1000

[260] A two (2) decimal place balance was used to weight the gelatin gum base. During the weighing operations, a plastic jar was placed on the balance and tared. Various amounts of gelatin gum base were tested due to the varying capacities of the different planetary mixers, the weights of 25, 50, 75, 100, 120, 150, 200, 300 and 500 grams were selected. The temperature was recorded using a digital thermometer with stainless steel probe by inserting the tip inside of the gelatin gum base. The final temperature was measured by repeating the process and swirling the stainless steel probe as to avoid coagulation as much as possible.

Mazerustar KK-300SS

[261] Parameters of 180 seconds time period in combination with 25, 50 and 75 grams were used for increasing G Force and RPM. For the Mazerustar KK-300SS: 182 G Force corresponds to 1600 RPM; 230 G Force corresponds to 1800 RPM; and 284 G Force corresponds to 2000 RPM.

[262] Parameters of G Force of 284 (2000 RPM) in combination with 75 grams were used for increasing the time of melting in the Mazerustar. For the Mazerustar KK-300SS times of 180, 300 and 450 seconds were used.

[263] Parameters of G force of 284 (2000 RPM) in combination with 180 seconds were used for increasing the mass of melting in the Mazerustar. For the Mazerustar KK-300SS mass of 25, 50 and 75 grams were used.

[264] Parameters of G force of 284 (2000 RPM) in combination with 300 seconds were used for increasing the mass of melting in the Mazerustar. For the Mazerustar KK-300SS mass of 25, 50, 75 and 100 grams were used.

Mazerustar KK-400

[265] Parameters of 450 seconds time period in combination with 75 grams were used for increasing G Force and RPM. For the Mazerustar KK-400: 170 G Force corresponds to 1058 RPM; 226 G Force corresponds to 1218 RPM; and 273 G Force corresponds to 1340 RPM.

[266] Parameters of G Force of 273 (1340 RPM) in combination with 25, 50 and 75 grams were used for increasing the time of melting in the Mazerustar. For the Mazerustar KK-400 times of 180, 300, 450 and 600 seconds were used.

[267] Parameters of G Force of 273 (1340 RPM) in combination with 100 grams were used for increasing the time of melting in the Mazerustar. For the Mazerustar KK-400 times of 300, 450 and 600 seconds were used.

[268] Parameters of G force of 273 (1340 RPM) in combination with 180 seconds were used for increasing the mass of melting in the Mazerustar. For the Mazerustar KK-400 mass of 25, 50 and 75 grams were used.

[269] Parameters of G force of 284 (2000 RPM) in combination with 300 and 450 seconds were used for increasing the mass of melting in the Mazerustar. For the Mazerustar KK-400 mass of 25, 50, 75 and 100 grams were used.

[270] Parameters of G force of 284 (2000 RPM) in combination with 600 seconds were used for increasing the mass of melting in the Mazerustar. For the Mazerustar KK-400 mass of 25, 50, 75, 100 and 150 grams were used.

Mazerustar KK-1000

[271] Parameters of 450 seconds time period in combination with 200 grams were used for increasing G Force and RPM. For the Mazerustar KK-1000: 149 G Force corresponds to 770 RPM; 186 G Force corresponds to 860 RPM; and 227 G Force corresponds to 950 RPM.

[272] Parameters of G Force of 227 (950 RPM) in combination with 200 grams were used for increasing the time of melting in the Mazerustar. For the Mazerustar KK-1000 times of 180, 300, 450 and 600 seconds were used.

[273] Parameters of G force of 227 (950 RPM) in combination with 450 seconds were used for increasing the mass of melting in the Mazerustar. For the Mazerustar KK-1000 mass of 100, 200, 300 and 500 grams were used.

Results and discussion

[274] The following can be deduced from the results reported in tables 20 and 20.1 to 20.20 as well as in Figs. 36-38.

[275] The gelatin particles melted as the planetary motion induced friction between the particles and the inside surfaces of the jar. By nature, gelatin gum base has an adhesive surface. The gelatin gum base chunk volume and mass increased proportionally. However, the surface area adhering to the plastic of the same chunk of gelatin gum base also increased but at a lower rate than the mass. The smaller the mass of the gelatin chunk, the more difficulty the planetary mixer had of dislodging the mass of gelatin stuck on the wall and, thus, not being able to melt.

[276] The results show that there was a direct correlation between melting and the planetary mixer's G Force/RPM speed, time and mass of gum base gelatin. The final temperature of the melted substance increased as the G Force/RPM speed increased and the time increased. The final temperature of the melted substance followed a quadratic function, where a minimal and a maximal mass can be used to melt the gelatin gum base.

Example 10

[277] In this example, an Unguator cartridge was used to disperse ingredients the herein described superimposed revolution and rotation movements. The cartridge is fitted with an adaptor to fit the Unguator cartridge into a receiving basket of the planetary mixer. The ingredients used were a pharmaceutically acceptable carrier, excipient or diluent, Versapro Cream Base and a red dye, as a tracer. The amount of Versapro added into the Unguator cartridge was the nominal value recommended by the Unguator manufacturer. The dispersed cream was then visually assessed for red dye homogeneity dispersion. Note that the rotation speed (rpm) was kept at a value of 40% of the revolution speed (rpm).

Table 23 – Versapro in Unguator cartridge

Volume of Unguator cartridge	revolution (rpm)	Temperature (°C), Time	Observation
15 ml	400	25.1 (120 sec)	Not completely homogeneous mix, very light color in the middle.
	1000	23.7 (30 sec) 25.7 (120 sec)	Dye reached the bottom, homogeneous mix (30 and 120 sec)
	1500	24.1 (30 sec) 26.2 (120 sec)	Dye reached the bottom, homogeneous mix (30 and 120 sec)
	2000		No leakage beyond the piston. However, jar came loose from the lid and cream spilled out.
20 ml	400	24.1 (120 sec)	Not completely homogeneous, lighter color in the middle (30 sec). Dye reached the bottom, homogeneous mix and uniform color. (120 sec)
	1000	25.8 (30 sec) 25.8 (120 sec)	Dye reached the bottom, homogeneous mix and uniform color (30 sec and 120 sec)
	1500	25.8 (30 sec) 26.3 (120 sec)	Dye reached the bottom, homogeneous mix and uniform color (30 sec and 120 sec)
	2000		No leakage beyond the piston. However, jar came loose and detached from the lid and cream spilled out.
30 ml	400		Dye did not reach the bottom, not a homogeneous mix. (30 sec and 120 sec)

	1000	23.2 (30 sec) 24.6 (120 sec)	Dye reached the bottom, homogeneous mix (30 sec and 120 sec)
	1500	23.1 (30 sec)	Dye reached the bottom, homogeneous mix (30 sec) No leakage beyond the piston. However, jar came loose and detached from the lid and cream spilled out. (60 sec)
	2000	-	-
50 ml	400	23.9 (120 sec)	Dye did not reach the bottom, not a homogeneous mix (30 sec) Dye reached the bottom, homogeneous mix and uniform color. (120 sec)
	1000	23.1 (30 sec) 25.1 (120 sec)	Dye reached the bottom, homogeneous mix (30 sec and 120 sec)
	1500		No leakage beyond the piston. However, jar came loose and detached from the lid and cream spilled out. (30 sec)
100 ml	400	23.1 (120 sec)	Dye did not reach the bottom, not a homogeneous mix (30 sec) Dye reached the bottom, homogeneous mix and uniform color. (120 sec)
	1000	24.2 (30 sec) 24.2 (120 sec)	Dye reached the bottom, homogeneous mix (30 sec)
	1500	23.2 (30 sec)	Dye reached the bottom, homogeneous mix and uniform color. However, jar had become slightly loose from the lid.(30 sec) No leakage beyond the piston. However, jar came loose and detached from the lid and cream spilled out.(60 sec)

[278] Safe dispersing parameters so as to avoid leakage, thus, appear to be 1000 rpm at 0.5 min, and are applicable to all sizes of the Unguator cartridge line of containers with the herein described adapters.

Example 11

[279] In this example, grinding of variable amounts of ingredient particles was performed the herein described superimposed revolution and rotation movements in a planetary mixer (Mazerustar kk-300ss, kk-400 or kk-1000) in presence of grinding media. The container was filled with grinding

media and the ingredient particles. The dispersing time and the dispersing speed parameters were modified, and a dispersing assessment was made, as indicated in the following tables.

[280] It is to be noted that this tables make reference to particle size distribution values such as D_{10} , D_{50} and D_{90} . These are known manners to represent particle size distribution. For example, D_{90} signifies the point in the size distribution, up to and including which, 90% of the total volume of material in the sample is 'contained'. For example, if the D_{90} is 844nm, this means that 90% of the sample has a size of 844 nm or smaller.

Table 24: Standard NaCl particle size (LOT number 613788, NDC 0629)

Surface Weighted Mean (μm)	248.715
Volume Weighted Mean (μm)	371.042
D_{10} (μm)	203.931
D_{50} (μm)	354.291
D_{90} (μm)	575.27

Table 25: Mazerustar KK-300SS – Constant time, variable G Force

	Test 1	Test 2	Test 3	Test 4
NaCl (grams)	22.90	22.90	22.90	22.90
RPM	1100	1300	1600	1800
G Force	86	120	182	230
Time (seconds)	60	60	60	60
Surface Weighted Mean (μm)	17.011	10.850	N/A	N/A
Volume Weighted Mean (μm)	171.164	178.076	N/A	N/A
D_{10} (μm)	7.593	5.077	N/A	N/A
D_{50} (μm)	44.899	31.239	N/A	N/A
D_{90} (μm)	725.785	826.723	N/A	N/A
Temperature Before ($^{\circ}\text{C}$)	23.7	24.2	N/A	N/A
Temperature After ($^{\circ}\text{C}$)	43.3	52.0	N/A	N/A

Table 26: Mazerustar KK-300SS – Variable time, constant G Force

	Test 1	Test 6	Test 7	Test 8	Test 9
NaCl (grams)	22.90	22.90	22.90	22.90	22.90
RPM	1100	1100	1100	1100	1100
G Force	86	86	86	86	86
Time (seconds)	60	90	120	180	300
Surface Weighted Mean (μm)	17.011	7.933	6.284	4.956	4.56

Volume Weighted Mean (μm)	171.164	41.888	32.521	32.939	42.691
D ₁₀ (μm)	7.593	3.992	3.190	2.292	2.012
D ₅₀ (μm)	44.899	21.823	17.793	14.002	12.835
D ₉₀ (μm)	725.785	81.408	66.279	59.787	109.449
Temperature Before ($^{\circ}\text{C}$)	23.7	22.1	24.3	23.5	26.0
Temperature After ($^{\circ}\text{C}$)	43.3	54.1	58.8	46.7	64.7

Table 27: Mazerustar KK-400 – Constant time, variable G Force

	Test 1	Test 2	Test 3	Test 4
NaCl (grams)	22.90	22.90	22.90	22.90
Revolution Setting #	5	6	7	8
Rotation Setting #	5	6	7	8
RPM	804	935	1058	1218
G Force	98	133	170	226
Time (seconds)	60	60	60	60
Surface Weighted Mean (μm)	23.095	11.283	6.553	5.915
Volume Weighted Mean (μm)	81.929	57.473	32.390	36.968
D ₁₀ (μm)	10.468	5.624	3.592	3.083
D ₅₀ (μm)	64.028	31.677	17.864	15.731
D ₉₀ (μm)	181.26	107.833	68.490	83.828
Temperature Before ($^{\circ}\text{C}$)	23.1	25.3	24.7	25.5
Temperature After ($^{\circ}\text{C}$)	34.1	47.3	63.7	78.4

Table 28: Mazerustar 400 – Variable time, constant G Force

	Test 1	Test 6	Test 7	Test 8	Test 9
NaCl (grams)	22.90	22.90	22.90	22.90	22.90
Revolution Setting #	5	5	5	5	5
Rotation Setting #	5	5	5	5	5
RPM	804	804	804	804	804
G Force	98	98	98	98	98
Time (seconds)	60	90	120	180	300
Surface Weighted Mean (μm)	23.095	11.527	8.580	5.84	4.82
Volume Weighted Mean (μm)	81.929	44.4229	33.358	35.459	33.206
D ₁₀ (μm)	10.468	5.889	4.613	2.864	2.278
D ₅₀ (μm)	64.028	31.852	22.848	16.457	13.084
D ₉₀ (μm)	181.26	101.156	76.524	35.459	66.116
Temperature Before ($^{\circ}\text{C}$)	23.1	26.6	24.9	26.9	26.3
Temperature After ($^{\circ}\text{C}$)	34.1	42.6	46.0	49.8	47.8

Methods

Reference point

[281] The Sodium Chloride (NaCl) powder was taken from the original packaged container (LOT number: 613788) with a stainless steel laboratory spatula and placed in an inert plastic container. The powder (NaCl) was transferred to the laser diffraction particle sizer MasterSizer 2000[®]. The data was collected and the distribution was noted at D₁₀, D₅₀ and D₉₀. These measurements consist of the reference points for the following milling experimental assay.

Mortar and Pestle

[282] A two (2) decimal place balance was used to weight the Sodium Chloride (NaCl) powder (LOT #613788). During the weighing operations, a weigh boat was placed on the balance and tared, two different amounts of powder (NaCl) were tested, i.e., 23 grams and 50 grams. Due to the volume capacity difference of the planetary mixers tested, the weights of 23 grams and 50 grams were selected. The results gathered from the 23 grams trituration steps were used to compare with the KK-300SS and KK-400. The results gathered from the 50 grams trituration steps were used to compare with the KK-1000. Once the desired mass of powder was weighed, the powder (NaCl) was then transferred from the weigh boat to a mortar and pestle. The triturating process began once the timer started. During testing, times of 60, 180 and 300 seconds were used. Also, two (2) different individuals performed the trituration process. Once the time of a trituration run had elapsed, the milled powder (NaCl) was transferred from the mortar to an inert plastic container. A random sample of 3 grams from the powder was placed in the laser diffraction particle sizer MasterSizer 2000[®]. The data was collected and the distribution was noted at D₁₀, D₅₀ and D₉₀. These measurements consisted of the reference points for the following milling experimental assay.

Mazerustar KK-300SS, KK-400 and KK-1000

[283] A two (2) decimal place balance was used to weigh the Sodium Chloride (NaCl) powder (LOT #613788). During the weighing operations, a stainless steel liner was placed on the balance and tared. Two different amounts of powder (NaCl), 22.90 grams and 53.00 grams, which each occupied ¼ of the volume of their respective liners, were tested. The 22.90 grams experiments were tested on the Mazerustar KK-300SS and KK-400 units. The 53.00 grams experiments were tested

on the Mazerustar KK-1000 unit. Once the desired mass of powder was weighed, the spherical grinding media of 8 mm diameter was added to the stainless steel container. For this experiment a total grinding media mass of 106.4 grams was used for the experiments with 22.90 grams of powder, and a total grinding media mass of 245.79 grams was used for the experiments with 53.00 grams of powder.

Mazerustar KK-300SS

[284] Times of 60 seconds were used for increasing G Force and RPM. For the Mazerustar KK-300SS: 86 G Force corresponds to 1100 RPM; 120 G Force corresponds to 1300 RPM; 182 G Force corresponds to 1600 RPM; 230 G Force corresponds to 1800 RPM.

[285] Parameters of G Force of 86 (1100 RPM) were used for increasing the time of milling in the Mazerustar. For the Mazerustar KK-300SS times of 60, 90, 120, 180 and 300 seconds were used.

Mazerustar KK-400

[286] Parameters of 60 seconds were used for increasing G Force and RPM. For the Mazerustar KK-400: 98 G Force corresponds to 804 RPM; 133 G Force corresponds to 935 RPM; 170 G Force corresponds to 1058 RPM; and 226 G Force corresponds to 1218 RPM.

[287] Parameters of G Force of 98 (804 RPM) were used for increasing the time of milling in the planetary mixer. For the Mazerustar KK-400 times of 60, 90, 120, 180 and 300 seconds were used.

Mazerustar KK-1000

[288] Parameters of 60 seconds were used for increasing G Force and RPM. For the Mazerustar KK-1000: 88 G Force corresponds to 590 RPM; 116 G Force corresponds to 680 RPM; 186 G Force corresponds to 960 RPM; 227 G Force corresponds to 960 RPM.

[289] Parameters of G Force of 88 (590 RPM) were used for increasing the time of milling in the planetary mixer. For the Mazerustar KK-1000 times of 60, 90, 120, 180 and 300 seconds were used.

[290] Once the time had elapsed, the milled powder was placed in an inert plastic container. A random sample of 3 grams from the powder was placed in the laser diffraction particle sizer

MasterSizer 2000[®]. The data was collected and the distribution was noted at D_{10} , D_{50} and D_{90} . These measurements were the reference points for the following milling experimental assay.

[291] Clean up for the planetary mixer and for the mortar and pestle took comparatively the same period of time.

Observations

Constant G force with increased time duration

[292] One can observe that compounding pharmaceutical ingredients using the herein described superimposed revolution and rotation movements in the presence of grinding media with a planetary mixer is very efficient compared to the conventional method of the mortar and pestle.

[293] The longer the duration, the finer the particles became. After 60 seconds, the planetary mixer could bring the (D_{10}) within 10 μm . The mortar and pestle could barely reach (D_{10}) of 10 μm after 300 seconds. It is important to note the overall particle size for the (D_{50}) and (D_{90}). The planetary mixer could reduce the particle size within 60 seconds for the overall particle size for the (D_{50}) and (D_{90}). After processing with the planetary mixer for a duration exceeding 180 seconds, the powder reached a state whereby the fineness of the powder exhibited hygroscopic properties of clumping, creating larger particle size.

Constant time duration with increased G Force

[294] One can observe that milling at higher G Force for the same duration diminished the particle size in the planetary mixer. G Forces higher than 170 demonstrated that particle size variance was very similar.

Temperature gain for 60 seconds at different G Force

[295] Increasing the G Force while maintaining a constant time milling time of 60 seconds generated more friction between the stainless steel liner and the zirconium coated balls, which in turn created a larger temperature gain. This temperature gain stabilised once the 180 G Force mark was passed.

Temperature gain for constant G Force at different time duration

[296] The temperature gain increased as the processing time increases. The temperature gain stabilised quickly for any value after the 90-second marks.

Table 29: Mazerustar KK-1000 – Constant time, variable G Force

	Test 1	Test 2	Test 3	Test 4
NaCl (grams)	53.00	53.00	53.00	53.00
Revolution Setting #	5	6	8	9
Rotation Setting #	5	6	8	9
RPM	590	680	860	960
G Force	88	116	186	227
Time (seconds)	60	60	60	60
Surface Weighted Mean (μm)	190.024	20.891	5.586	5.964
Volume Weighted Mean (μm)	375.514	80.659	28.893	40.497
D ₁₀ (μm)	184.331	9.437	2.845	2.900
D ₅₀ (μm)	361.686	60.390	15.174	15.937
D ₉₀ (μm)	602.621	182.817	63.131	97.955
Temperature Before ($^{\circ}\text{C}$)	22.7	25.6	23.7	24.8
Temperature After ($^{\circ}\text{C}$)	27.9	41.9	85.5	107.4

Table 30: Mazerustar 1000 – Variable time, constant G Force

	Test 1	Test 6	Test 7	Test 8	Test 9
NaCl (grams)	53.00	53.00	53.00	53.00	53.00
Rev #	5	5	5	5	5
Rot #	5	5	5	5	5
RPM	590	590	590	590	590
G Force	88	88	88	88	88
Time (seconds)	60	90	120	180	300
Surface Weighted Mean (μm)	190.024	17.128	10.585	6.498	10.365
Vol. Weighted Mean (μm)	375.514	69.509	40.890	33.689	96.187
D ₁₀ (μm)	184.331	7.750	5.386	3.295	5.12
D ₅₀ (μm)	361.686	45.419	28.919	19.327	32.163
D ₉₀ (μm)	602.621	141.883	93.219	68.821	127.26
Temperature Before ($^{\circ}\text{C}$)	22.7	24.8	26.4	24.9	24.9
Temperature After ($^{\circ}\text{C}$)	27.9	42.9	48.2	53.9	54.8

Table 31: Mortar & Pestle – Variable time & weight

	Test 1	Test 2	Test 3	Test 4	Test 5	Test 6
User	User 1	User 1	User 1	User 2	User 2	User 2
NaCl (grams)	22.90	22.90	22.90	22.90	22.90	22.90
Time (seconds)	60	180	300	60	180	300
D ₁₀ (µm)	79.86	19.108	10.27	128.563	26.732	8.070
D ₅₀ (µm)	322.183	218.789	127.252	329.516	253.368	103.698
D ₉₀ (µm)	564.429	459.647	326.609	567.004	493.422	287.631
Temp. Before (°C)	25.6	26.3	26.8	N/A	N/A	N/A
Temp. After (°C)	26.3	26.8	27.0	N/A	N/A	N/A

Table 32: Mortar & Pestle – Variable time & weight

	Test 7	Test 8	Test 9	Test 10	Test 11	Test 12
User	User 1	User 1	User 1	User 2	User 2	User 2
NaCl (grams)	50.00	50.00	50.00	50.00	50.00	50.00
Time (seconds)	60	180	300	60	180	300
D ₁₀ (µm)	187.352	157.311	99.553	184.351	114.791	89.662
D ₅₀ (µm)	358.969	346.437	327.158	348.63	331.814	322.701
D ₉₀ (µm)	593.531	586.343	567.563	584.389	575.718	561.756
Temperature Before (°C)	25.1	24.7	25.4	N/A	N/A	N/A
Temperature After (°C)	24.7	25.4	25.4	N/A	N/A	N/A

Example 12

[297] In the following experiment, a compounding composition including 3 API was dispersed in an excipient was prepared according to the herein described superimposed revolution and rotation movements, or using an Electric Mortar and Pestle (EMP) Mixer as control comparative mixing device. The characteristics of the resulting composition were assessed. Notably, this experiment demonstrated that the superimposed revolution and rotation movements can be implemented independently of the processing capacity or planetary mixer model used.

[298] Homogeneity was assessed by measuring the API potency with high performance liquid chromatography (HPLC) at three layers of a given mixing vessel (top, middle and bottom layers). The API potency was reported in the form of a weight/weight concentration on triplicate batches. In other words, the formulation for a given container and volume size was repeated three (3) times in order to obtain statistically significant data.

[299] The assays were performed with different planetary mixer models, namely the Mazerustar KK-300SS, KK-400W, and KK-1000W and an EMP Mixer.

[300] Samples were prepared using six (6) different mixer/volume configurations with a formula of Baclofen 2%, Cyclobenzaprine 6% and Diclofenac 10% in VersaPro™ Cream. Briefly, the baclofen and cyclobenzaprine hydrochloride were weighted into separate glass mortar and pestles. The baclofen and cyclobenzaprine hydrochloride were triturated until a fine powder with no grittiness was formed. In a glass mortar and pestle the desired quantity of baclofen, cyclobenzaprine hydrochloride and diclofenac sodium were combined. Desired amounts of ethoxy diglycol and pentylene glycol were incorporated into the powder blend until the powder blend was levigated and a smooth paste was achieved.

[301] The dispersing container (Mazerustar or EMP jar) was filled with the desired amount of Versapro Cream and placed into the respective device (planetary Mazerustar or EMP). The parameters for operating the devices were set, including revolution, rotation and time variables for the planetary mixers.

[302] The resulting 3 API formulation composition were separated in the container into three layers, namely top (T), middle (M) and bottom (B) layers.

Table 33: List of Ingredients for 3-API Formulation

Ingredient	grams or mL						NDC	Lot
	1	2	3	4	5	6		
	KK-300SS (200g)	KK-400W (300g)	KK-1000W (750g)	EMP (200g)	EMP (300g)	EMP (750 g)		
Baclofen USP	4	6	15	Baclofen USP	4	6	15	Baclofen USP
Cyclobenzaprine Hydrochloride USP	12	18	45	Cyclobenzaprine Hydrochloride USP	12	18	45	Cyclobenzaprine Hydrochloride USP
Diclofenac Sodium USP (Micronized)	20	30	75	Diclofenac Sodium USP (Micronized)	20	30	75	Diclofenac Sodium USP (Micronized)
Ethoxy Diglycol	9	13.5	36	Ethoxy Diglycol	9	13.5	36	Ethoxy Diglycol
Pentylene Glycol	8	12	30	Pentylene Glycol	8	12	30	Pentylene Glycol
VersaPro Cream Base	147	220.5	549	VersaPro Cream Base	147	220.5	549	VersaPro Cream Base

[303] The superimposed revolution and rotation movement parameters in the planetary mixer were (samples 1-3):

1. Mazerustar KK-300SS: 2000 RPM (revolution) / 800 RPM (rotation) for 30 sec (standard jar) [which provides a G force of 284 g]
2. Mazerustar KK-400W: 1340 RPM (revolution) / 1340 RPM (rotation) for 70 sec [which provides a G force of 273g]
3. Mazerustar KK-1000W: 960 RPM (revolution) / 950 RPM (rotation) for 130 sec [which provides a G force of 227g]

[304] The EMP parameters were (samples 4-6):

4. EMP 200 mL Jar: Lift Engine Step 01, Mix Engine Step 06 for 120 sec
5. EMP 300 mL Jar: Lift Engine Step 01, Mix Engine Step 06 for 120 sec
6. EMP 1 L Jar: Lift Engine Step 01, Mix Engine Step 06 for 180 sec

[305] Each of the resulting composition was then separated in top, middle and bottom layers and the concentration of each of the 3 API in each layer was measured with HPLC. The average concentration ([]), the standard deviation (SD) and the relative standard deviation (%RSD) were calculated for each API. The results are shown in the following Tables:

Table 34: Results for a composition including 3 API dispersed in Mazerustar KK-300SS

Formulation #	Sample #	Layer (top, middle, bottom)	Baclofen (w/w)	Cyclobenzaprine (w/w)	Diclofenac (w/w)
1	1	Top	2.045	6.144	10.045
	2	Middle	2.019	6.070	9.925
	3	Bottom	2.070	6.175	10.114
2	4	Top	1.992	6.129	9.970
	5	Middle	2.085	6.251	10.156
	6	Bottom	2.032	6.270	10.191
3	7	Top	2.071	6.334	10.319
	8	Middle	2.070	6.311	10.265
	9	Bottom	2.116	6.421	10.456

Table 35: Results for a composition including 3 API dispersed in Mazerustar KK-400W

Formulation #	Sample #	Layer (top, middle, bottom)	Baclofen (w/w)	Cyclobenzaprine (w/w)	Diclofenac (w/w)
4	10	Top	2.089	6.332	10.334
	11	Middle	2.113	6.345	10.375
	12	Bottom	2.127	6.316	10.352
5	13	Top	2.069	6.340	10.292
	14	Middle	2.090	6.426	10.486
	15	Bottom	2.051	6.397	10.438
6	16	Top	2.067	6.321	10.306
	17	Middle	2.094	6.312	10.3
	18	Bottom	2.081	6.394	10.41

Table 36: Results for a composition including 3 API dispersed in Mazerustar KK-1000W

Formulation #	Sample #	Layer (top, middle, bottom)	Baclofen (w/w)	Cyclobenzaprine (w/w)	Diclofenac (w/w)
7	19	Top	2.085	6.432	10.556
	20	Middle	2.068	6.435	10.535
	21	Bottom	2.039	6.295	10.32
8	22	Top	2.105	6.426	10.374
	23	Middle	2.106	6.427	10.389
	24	Bottom	2.086	6.46	10.418
9	25	Top	2.130	6.369	10.382
	26	Middle	2.108	6.224	10.179
	27	Bottom	2.107	6.294	10.28

Table 37: Results for a composition including 3 API dispersed in EMP 200 mL Jar

Formulation #	Sample #	Layer (top, middle, bottom)	Baclofen (w/w)	Cyclobenzaprine (w/w)	Diclofenac (w/w)
10	28	Top	2.165	6.475	10.612
	29	Middle	2.021	6.089	9.985
	30	Bottom	2.024	6.11	10.021
11	31	Top	2.133	6.44	10.536
	32	Middle	2.12	6.288	10.285
	33	Bottom	2.05	6.212	10.169
12	34	Top	2.209	6.457	10.565
	35	Middle	2.074	6.182	10.136
	36	Bottom	2.113	6.279	10.288

Table 38: Results for a composition including 3 API dispersed in EMP 300 ml Jar

Formulation #	Sample #	Layer (top, middle, bottom)	Baclofen (w/w)	Cyclobenzaprine (w/w)	Diclofenac (w/w)
13	37	Top	2.235	6.674	10.935
	38	Middle	2.082	6.272	10.295
	39	Bottom	2.208	6.48	10.604
14	40	Top	2.185	6.557	10.752
	41	Middle	2.087	6.205	10.15
	42	Bottom	1.998	6.047	9.908
15	43	Top	2.23	6.743	11.035
	44	Middle	2.089	6.228	10.205
	45	Bottom	2.044	6.216	10.193

Table 39: Results for a composition including 3 API dispersed in EMP 1L Jar

Formulation #	Sample #	Layer (top, middle, bottom)	Baclofen (w/w)	Cyclobenzaprine (w/w)	Diclofenac (w/w)
16	46	Top	2.113	6.376	10.454
	47	Middle	2.073	6.097	10.003
	48	Bottom	2.101	6.147	10.093
17	49	Top	2.031	6.294	10.301
	50	Middle	2.094	6.488	10.558
	51	Bottom	1.987	6.182	10.021
18	52	Top	2.098	6.396	10.284
	53	Middle	2.154	6.506	10.486
	54	Bottom	2.088	6.182	9.932

Table 40: %RSD Results for the compositions of Table 34 to 39

Formulation #	Baclofen, 2%	Cyclobenzaprine, 6%	Diclofenac, 10%
	%RSD		
1	1.2%	0.9%	1.0%
2	2.3%	1.2%	1.2%
3	1.3%	0.9%	1.0%
4	0.9%	0.2%	0.2%
5	0.9%	0.7%	1.0%
6	0.6%	0.7%	0.6%
7	1.1%	1.3%	1.2%
8	0.5%	0.3%	0.2%
9	0.6%	1.2%	1.0%
10	4.0%	3.5%	3.4%

11	2.1%	1.8%	1.8%
12	3.3%	2.2%	2.1%
13	3.8%	3.1%	3.0%
14	4.5%	4.2%	4.2%
15	4.6%	4.7%	4.6%
16	1.0%	2.4%	2.3%
17	2.6%	2.4%	2.6%
18	1.7%	2.6%	2.7%

Example 13

[306] In the following experiment, a compounding composition including 2 API was dispersed in an excipient was prepared according to the herein described superimposed revolution and rotation movements, or using an Electric Mortar and Pestle (EMP) Mixer as control comparative mixing device. The characteristics of the resulting composition were assessed. Notably, this experiment demonstrated that the superimposed revolution and rotation movements can be implemented independently of the processing capacity or planetary mixer model used.

[307] Homogeneity was assessed as in Example 12. The dispersing processes were performed with the same devices as in Example 12.

[308] Samples were prepared using six (6) different mixer/volume configurations with a formula of Estradiol 0.05% and Estriol 0.2% in VersaPro Cream. Briefly, the estradiol and estriol were weighted into separate plastic weigh boats. A 3 decimal place balance was used to prepare the formulation. Desired amounts of propylene glycol were incorporated into the powder blend until the powder blend was levigated and a smooth homogeneous liquid. The dispersing container (Mazerustar or EMP jar) was filled with the desired amount of Versapro Cream and placed into the respective device (planetary Mazerustar or EMP). The parameters for operating the devices were set, including revolution, rotation and time variables for the planetary mixers.

[309] The resulting 2 API formulation composition were separated in the container into three layers, namely top (T), middle (M) and bottom (B) layers.

Table 41: List of Ingredients for 2-API Formulation

Ingredient	grams or mL						NDC	Lot
	1	2	3	4	5	6		
	KK-300SS (200g)	KK-400 (300g)	KK-1000 (750g)	EMP (200g)	EMP (300g)	EMP (750 g)		
Estradiol, USP (Micronized)	0.1	0.15	0.375	0.1	0.15	0.375	0869	614901/B
Estriol USP (Micronized)	0.4	0.6	1.5	0.4	0.6	1.5	0732	615107/B
Propylene Glycol	1	1.5	3.75	1	1.5	3.75	0510	605764/C
VersaPro Cream Base	198.5	297.75	744.375	198.5	297.75	744.375	2529	611448

[310] The superimposed revolution and rotation movement parameters in the planetary mixer (samples 1-3) and the EMP parameters (samples 4-6) were the same as in Example 12.

[311] Each of the resulting composition was then separated and analyzed as in Example 12. The results are shown in the following Tables:

Table 42: Results for a composition including 2 API dispersed in KK-300SS

Formulation #	Sample #	Layer (top, middle, bottom)	Estriol (w/w)	Estradiol(w/w)
19	55	Top	0.181	0.055
	56	Middle	0.179	0.055
	57	Bottom	0.183	0.054
20	58	Top	0.211	0.046
	59	Middle	0.204	0.044
	60	Bottom	0.208	0.045
21	61	Top	0.199	0.048
	62	Middle	0.198	0.047
	63	Bottom	0.196	0.047

Table 43: Results for a composition including 2 API dispersed in Mazerustar KK-400W

Formulation #	Sample #	Layer (top, middle, bottom)	Estriol (w/w)	Estradiol(w/w)
22	64	Top	0.195	0.049
	65	Middle	0.194	0.048
	66	Bottom	0.194	0.049
23	67	Top	0.201	0.048
	68	Middle	0.201	0.048
	69	Bottom	0.201	0.048
24	70	Top	0.18	0.05
	71	Middle	0.181	0.051
	72	Bottom	0.181	0.05

Table 44: Results for a composition including 2 API dispersed in Mazerustar KK-1000W

Formulation #	Sample #	Layer (top, middle, bottom)	Estriol (w/w)	Estradiol(w/w)
25	73	Top	0.201	0.05
	74	Middle	0.203	0.051
	75	Bottom	0.202	0.05
26	76	Top	0.198	0.037
	77	Middle	0.198	0.037
	78	Bottom	0.197	0.037
27	79	Top	0.203	0.051
	80	Middle	0.201	0.051
	81	Bottom	0.201	0.051

Table 45: Results for a composition including 2 API dispersed in EMP 200 mL Jar

Formulation #	Sample #	Layer (top, middle, bottom)	Estriol (w/w)	Estradiol(w/w)
28	82	Top	0.236	0.058
	83	Middle	0.19	0.047
	84	Bottom	0.169	0.041
29	85	Top	0.247	0.064
	86	Middle	0.164	0.043
	87	Bottom	0.132	0.034
30	88	Top	0.303	0.07
	89	Middle	0.179	0.041
	90	Bottom	0.141	0.033

Table 46: Results for a composition including 2 API dispersed in EMP 300 mL Jar

Formulation #	Sample #	Layer (top, middle, bottom)	Estriol (w/w)	Estradiol(w/w)
31	91	Top	0.213	0.055
	92	Middle	0.207	0.053
	93	Bottom	0.177	0.045
32	94	Top	0.207	0.053
	95	Middle	0.168	0.043
	96	Bottom	0.17	0.044
33	97	Top	0.204	0.056
	98	Middle	0.203	0.055
	99	Bottom	0.193	0.053

Table 47: Results for a composition including 2 API dispersed in EMP 1 L Jar

Formulation #	Sample #	Layer (top, middle, bottom)	Estriol (w/w)	Estradiol(w/w)
34	100	Top	0.183	0.044
	101	Middle	0.184	0.044
	102	Bottom	0.178	0.043
35	103	Top	0.15	0.038
	104	Middle	0.16	0.041
	105	Bottom	0.16	0.041
36	106	Top	0.183	0.043
	107	Middle	0.166	0.039
	108	Bottom	0.174	0.041

Table 48: %RSD Results for the compositions of Tables 42 to 47

Formulation	Estriol	Estradiol
	%RSD	
19	1.1%	1.1%
20	1.7%	2.2%
21	0.8%	0.0%
22	0.3%	1.2%
23	0.0%	0.0%
24	0.3%	1.1%
25	0.5%	1.1%
26	0.3%	0.0%
27	0.6%	0.0%
28	17.3%	17.7%
29	32.8%	32.8%
30	40.8%	40.6%
31	9.7%	10.4%
32	12.1%	11.8%
33	3.0%	2.8%
34	1.8%	1.3%
35	3.7%	4.3%
36	4.9%	4.9%

[312] Other examples of implementations will become apparent to the reader in view of the teachings of the present description and as such, will not be further described here.

[313] Note that titles or subtitles may be used throughout the present disclosure for convenience of a reader, but in no way these should limit the scope of the invention. Moreover, certain theories may be proposed and disclosed herein; however, in no way they, whether they are right or wrong, should limit the scope of the invention so long as the invention is practiced according to the present disclosure without regard for any particular theory or scheme of action.

[314]

[315] It will be understood by those of skill in the art that throughout the present specification, the term “a” used before a term encompasses embodiments containing one or more to what the term refers. It will also be understood by those of skill in the art that throughout the present specification, the term “comprising”, which is synonymous with “including,” “containing,” or “characterized by,” is inclusive or open-ended and does not exclude additional, un-recited elements or method steps.

[316] Unless otherwise defined, all technical and scientific terms used herein have the same meaning as commonly understood by one of ordinary skill in the art to which this disclosure pertains. In the case of conflict, the present document, including definitions will control.

[317] As used in the present disclosure, the terms “around”, “about” or “approximately” shall generally mean within the error margin generally accepted in the art. Hence, numerical quantities given herein generally include such error margin such that the terms “around”, “about” or “approximately” can be inferred if not expressly stated.

[318] In the present disclosure, each of the variously stated ranges is intended to be continuous so as to include each numerical parameter between the stated minimum and maximum value of each range. For Example, a range of about 1 to about 4 includes: about 1, 1, about 2, 2, about 3, 3, about 4, and 4.

[319] Although various embodiments of the disclosure have been described and illustrated, it will be apparent to those skilled in the art in light of the present description that numerous modifications and variations can be made. The scope of the invention is defined more particularly in the appended claims.

Claims

1. A method of operating a device configured for performing superimposed revolution and rotation movements on a container, comprising selecting an operating parameter from a plurality of operating parameters, wherein the plurality of operating parameters includes an operating parameter associated with performing superimposed revolution and rotation movements on a container, wherein the movements are sufficient for melting a plurality of pieces of gelatin gum based material contained in the container into a pourable composition for making a troche or suppository.
2. The method according to claim 1, wherein the melting is obtained without addition of external heat.
3. The method according to claim 1 or 2, wherein the movements are sufficient for melting and homogenizing the gelatin gum based material.
4. The method according to any one of claims 1 to 3, wherein the superimposed revolution and rotation movements are performed for at least 20 seconds.
5. The method according to claim 4, wherein the superimposed revolution and rotation movements are performed for up to 900 seconds.
6. The method according to any one of claims 1 to 5, wherein the superimposed revolution and rotation movements induce a maximal G force of at least 50 g.
7. The method according to claim 6, wherein the maximal G force is of up to 500 g.
8. The method according to claim 6, wherein the maximal G force is selected from 50 g to 400 g.
9. The method according to any one of claims 1 to 5, wherein the superimposed revolution and rotation movements are performed at a revolution speed of at least 400 revolution per minute (rpm).
10. The method according to claim 9, wherein the revolution speed is selected in the range of from 400 to 4000 rpm.

11. The method according to any one of claims 1 to 10, wherein the superimposed revolution and rotation movements have a revolution:rotation ratio of 10:4.
12. The method according to any one of claims 1 to 11, wherein the container has a base diameter (B) and the plurality of pieces occupy a height (H) within the container such that there is a height-to-base ratio (HBR) of 0.75:1 to 1.5:1.
13. The method according to any one of claims 1 to 12, wherein the troche or suppository base further comprise glycerin.
14. The method according to any one of claims 1 to 13, wherein the operating parameter for melting the plurality of pieces of the gelatin gum based material contained in the container into the pourable composition is for making a troche or suppository.
15. The method according to claim 14, wherein the troche is a gummy.
16. The method according to any one of claims 1 to 15, wherein the pourable composition includes an active pharmaceutical ingredient (API).
17. The method according to claim 16, wherein the API includes one or more cannabinoid(s).
18. The method according to claim 17, wherein the one or more cannabinoid(s) includes cannabidiol (CBD) or tetrahydrocannabinol (THC).
19. The method according to any one of claims 1 to 18, for compounding a personalized medicine product.
20. The method according to any one of claims 1 to 19, wherein the movements cause an elevation of temperature to the material of at least 20 °C.
21. The method according to any one of claims 1 to 19, wherein the movements cause an elevation of temperature to the material of at least 30 °C.
22. A compounding method, comprising
 - a) placing a plurality of pieces of a gelatin gum based material into a container; and

- b) melting the plurality of pieces to obtain a pourable composition for making a troche or suppository by subjecting the container to superimposed revolution and rotation movements.
23. The compounding method according to claim 22, wherein the melting is obtained without addition of external heat.
24. The compounding method according to claim 22 or 23, wherein step b) further includes melting and homogenizing the gelatin gum based material.
25. The compounding method according to any one of claims 22 to 24, the method further comprising pouring the liquid composition into a mold and cooling the liquid composition to obtain a troche or suppository.
26. The compounding method according to claim 25, wherein the troche is a solid, semi-solid or chewable composition.
27. The compounding method according to claim 25, wherein the troche is a gummy.
28. The compounding method according to any one of claims 22 to 27, wherein the superimposed revolution and rotation movements are performed for at least 20 seconds.
29. The compounding method according to claim 28, wherein the superimposed revolution and rotation movements are performed for up to 900 seconds.
30. The compounding method according to any one of claims 22 to 29, wherein the superimposed revolution and rotation movements induce a maximal G force to contents in the container of less than 500 g.
31. The compounding method according to claim 30, wherein the maximal G force is from 50 g to 400 g.
32. The compounding method according to any one of claims 22 to 31, wherein the movements have a revolution:rotation ratio of 10:4.

33. The compounding method according to claim 32, wherein the movements are performed at a revolution speed of at least 400 revolution per minute (rpm).
34. The compounding method according to claim 33, wherein the revolution speed is from 400 to 4000 rpm.
35. The compounding method according to any one of claims 22 to 34, wherein the container has a base diameter (B) and the plurality of pieces occupy a height (H) within the container such that there is a height-to-base ratio (HBR) of 0.75:1 to 1.5:1.
36. The compounding method according to any one of claims 22 to 35, wherein the pourable composition includes an active pharmaceutical ingredient (API).
37. The compounding method according to claim 36, wherein the API includes one or more cannabinoid(s).
38. The compounding method according to claim 37, wherein the one or more cannabinoid(s) includes cannabidiol (CBD) or tetrahydrocannabinol (THC).
39. The compounding method according to any one of claims 22 to 35, wherein step b) further comprises subjecting the container to first superimposed revolution and rotation movements sufficient to melt the plurality of troche or suppository base pieces and subsequently subjecting the container to second superimposed revolution and rotation movements.
40. The compounding method according to claim 39, wherein step b) further comprises adding an active pharmaceutical ingredient (API) to the pourable composition after the first superimposed revolution and rotation movements and before the second superimposed revolution and rotation movements.
41. The compounding method according to claim 40, wherein the API includes one or more cannabinoid(s).
42. The compounding method according to claim 41, wherein the one or more cannabinoid(s) includes cannabidiol (CBD) or tetrahydrocannabinol (THC).

43. The compounding method according to any one of claims 22 to 42, wherein the troche or suppository base further includes glycerin.
44. The compounding method according to any one of claims 22 to 43, wherein the movements cause an elevation of temperature to the material of at least 20 °C.
45. The compounding method according to any one of claims 22 to 43, wherein the movements cause an elevation of temperature to the material of at least 30 °C.
46. A device for use in melting a plurality of pieces of gelatin gum based material for making a troche or suppository, wherein the device is configured for performing superimposed revolution and rotation movements on a container containing said plurality of pieces, wherein the movements induce an elevation in temperature sufficient for melting the plurality of pieces into the pourable composition.
47. The device for the use according to claim 46, wherein the melting is obtained without addition of external heat.
48. The device for the use according to claim 46 or 47, wherein the movements are sufficient for melting and homogenizing the gelatin gum based material.
49. The device for the use according to any one of claims 46 to 48, wherein the movements are performed for at least 20 seconds.
50. The device for the use according to claim 49, wherein the movements are performed for up to 900 seconds.
51. The device for the use according to any one of claims 46 to 50, wherein the movements induce a maximal G force of less than 500 g.
52. The device for the use according to claim 51, wherein the maximal G force is from 50 g to 400 g.
53. The device for the use according to any one of claims 46 to 52, wherein the movements have a revolution:rotation ratio of 10:4.

54. The device for the use according to claim 53, wherein the movements are performed at a revolution speed of at least 400 revolution per minute (rpm).
55. The device for the use according to claim 54, wherein the revolution speed is from 400 to 4000 rpm.
56. The device for the use according to any one of claims 46 to 55, wherein the troche or suppository base further comprises glycerin.
57. The device for the use according to any one of claims 46 to 56, for making a troche or suppository.
58. The device for the use according to claim 57, wherein the troche is a gummy.
59. The device for the use according to any one of claims 46 to 58, wherein the pourable composition includes an active pharmaceutical ingredient (API).
60. The device for the use according to claim 59, wherein the API includes one or more cannabinoid(s).
61. The device for the use according to claim 60, wherein the one or more cannabinoid(s) includes cannabidiol (CBD) or tetrahydrocannabinol (THC).
62. The device for the use according to any one of claims 46 to 61, wherein the movements cause an elevation of temperature to the material of at least 20 °C.
63. The device for the use according to any one of claims 46 to 61, wherein the movements cause an elevation of temperature to the material of at least 30 °C.
64. The device for the use according to any one of claims 46 to 63, in combination with instructions for melting the troche or suppository base.
65. A device configured for presenting a user with a set of predetermined operating parameters for operating the device, the set of operating parameters comprising an operating parameter associated with performing superimposed revolution and rotation movements on a container, wherein the movements are sufficient for melting a plurality of pieces of a gelatin gum based

material contained in the container into a pourable composition for making a troche or suppository.

66. The device according to claim 65, wherein the melting is obtained without addition of external heat.
67. The device according to claim 65 or 66, wherein the movements are sufficient for melting and homogenizing the gelatin gum based material.
68. The device according to any one of claims 65 to 67, wherein the movements are performed for at least 20 seconds.
69. The device according to claim 68, wherein the movements are performed for up to 900 seconds.
70. The device according to any one of claims 65 to 69, wherein the superimposed revolution and rotation movements induce a maximal G force of at least 50 g.
71. The device according to claim 70, wherein the maximal G force is of up to 500 g.
72. The device according to claim 70, wherein the maximal G force is from 50 g to 400 g.
73. The device according to any one of claims 65 to 72, wherein the superimposed revolution and rotation movements are performed at a revolution speed of at least 400 revolution per minute (rpm).
74. The device according to claim 73, wherein the revolution speed is selected in the range of from 400 to 4000 rpm.
75. The device according to any one of claims 65 to 74, the movements having a revolution:rotation ratio of 10:4.
76. The device according to any one of claims 65 to 75, wherein the container has a base diameter (B) and the plurality of pieces occupy a height (H) within the container such that there is a height-to-base ratio (HBR) of 0.75:1 to 1.5:1.
77. The device according to any one of claims 65 to 76, wherein the troche or suppository base further comprise glycerin.

78. The device according to any one of claims 65 to 77, for making a suppository or troche.
79. The device according to claim 78, wherein the troche is a gummy.
80. The device according to any one of claims 65 to 79, wherein the pourable composition includes an active pharmaceutical ingredient (API).
81. The device according to claim 80, wherein the API includes one or more cannabinoid(s).
82. The device according to claim 81, wherein the one or more cannabinoid(s) includes cannabidiol (CBD) or tetrahydrocannabinol (THC).
83. The device according to any one of claims 65 to 82, wherein the movements cause an elevation of temperature to the material of at least 20 °C.
84. The device according to any one of claims 65 to 82, wherein the movements cause an elevation of temperature to the material of at least 30 °C.
85. The device according to any one of claims 65 to 84, in combination with instructions for melting the troche or suppository base.

+

1/36

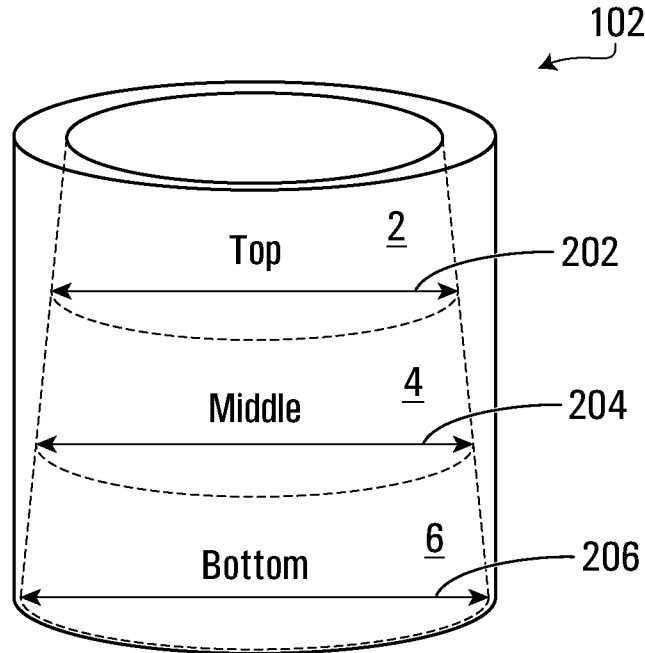
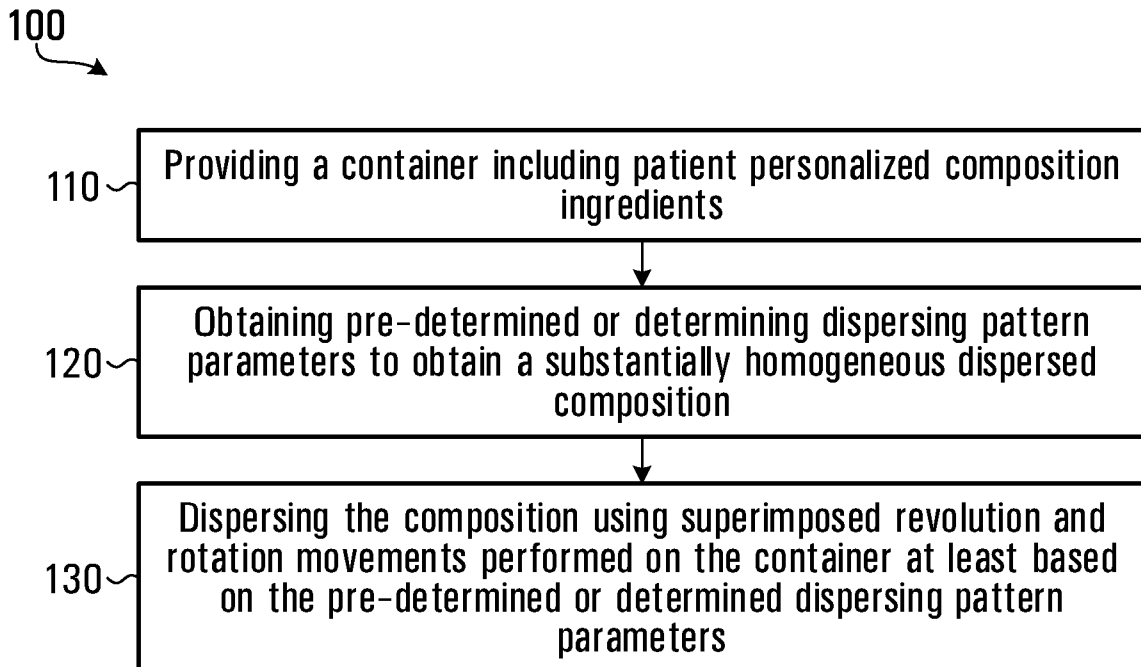
**FIG. 1****FIG. 2**

+

+

2/36

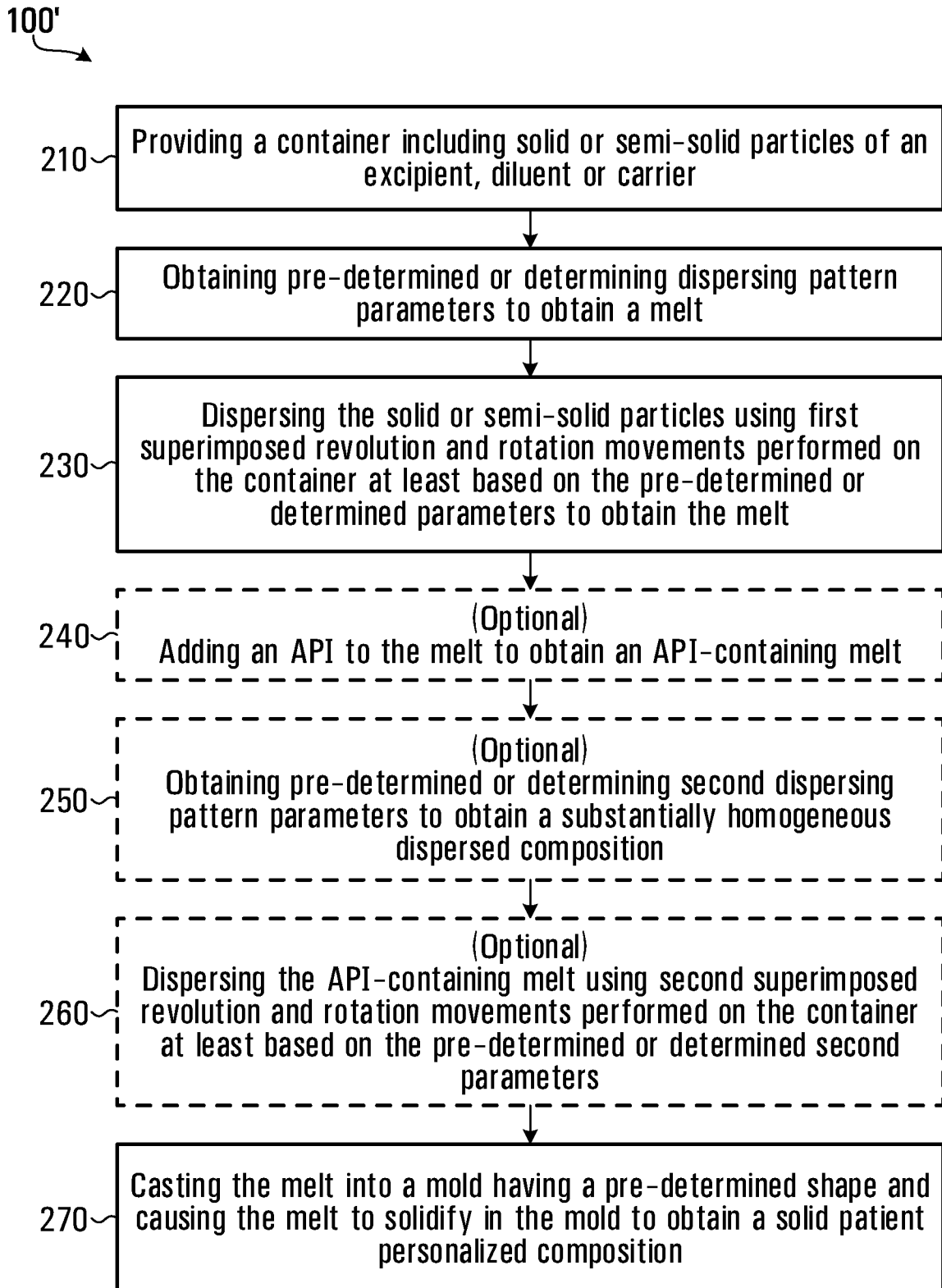

FIG. 3

+

+

3/36

100"

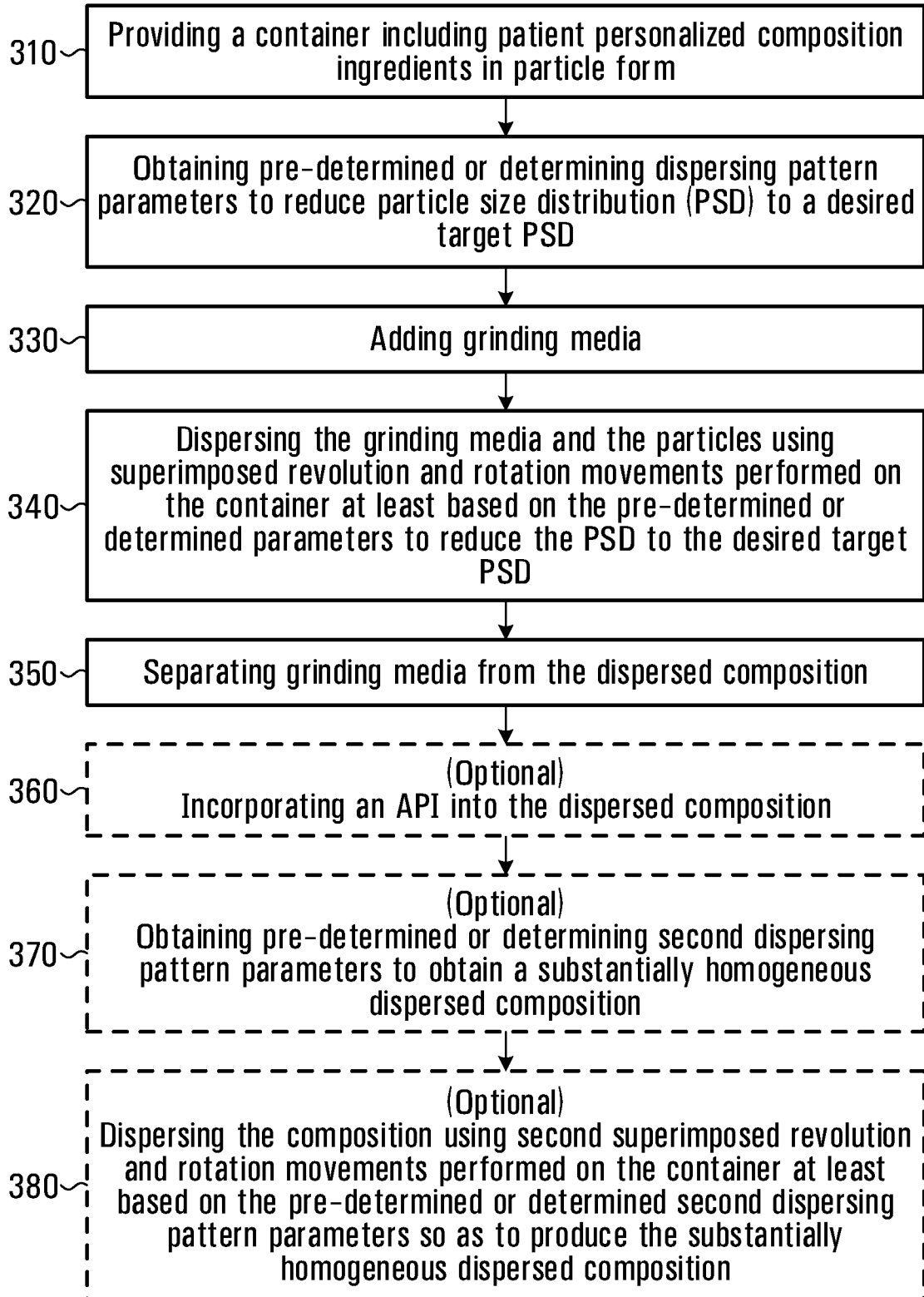
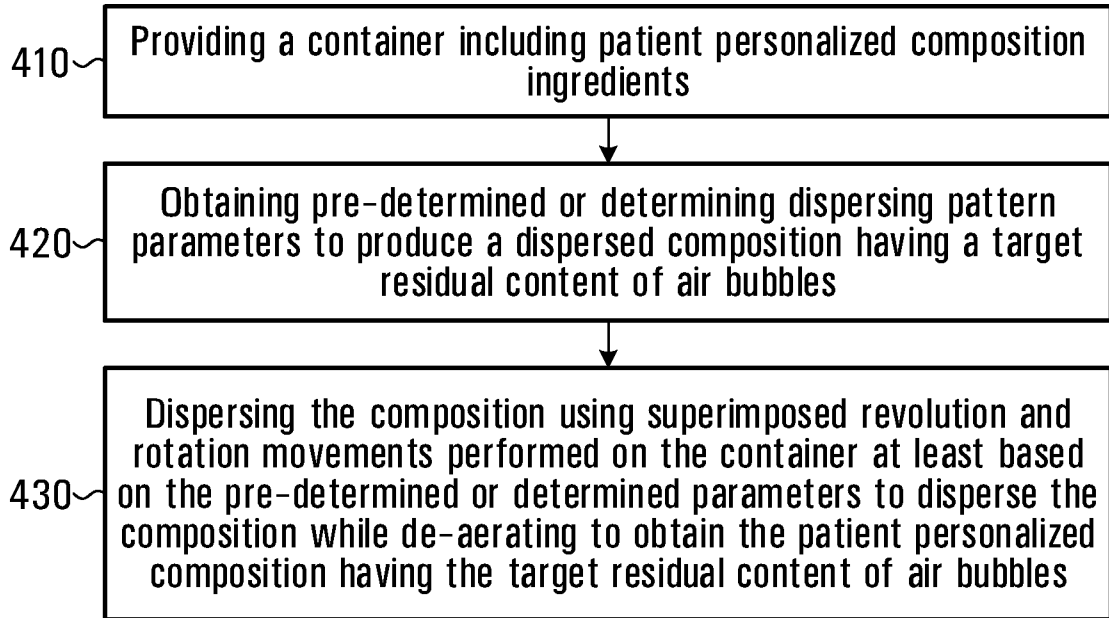

FIG. 4

+

+

4/36

100'''
→**FIG. 5**

+

+

5/36

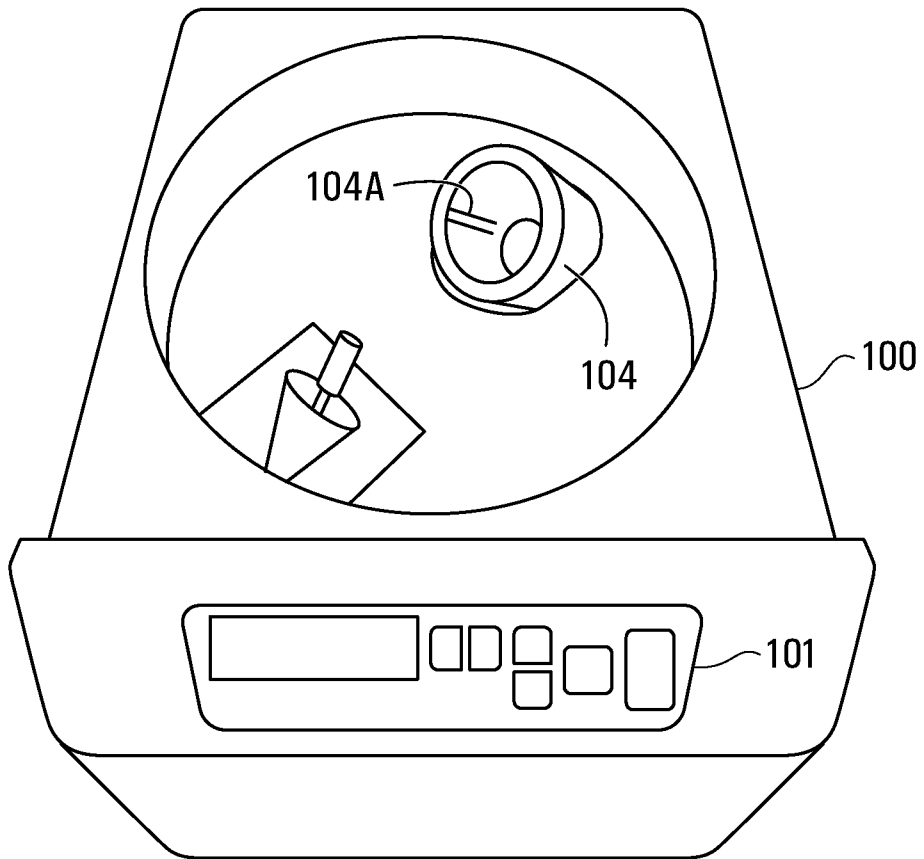
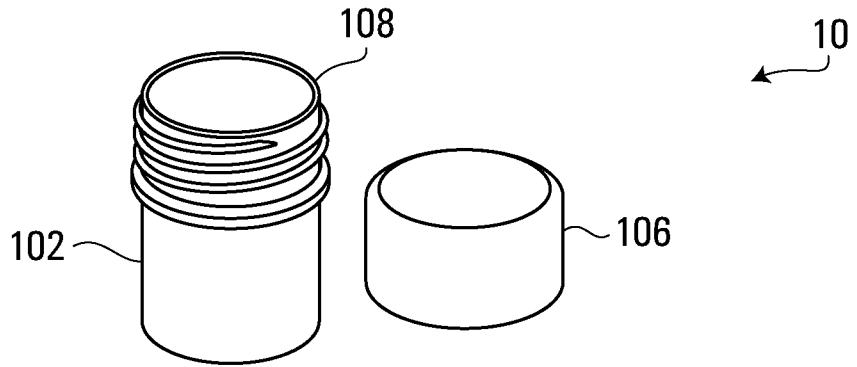

FIG. 6

+

+

6/36

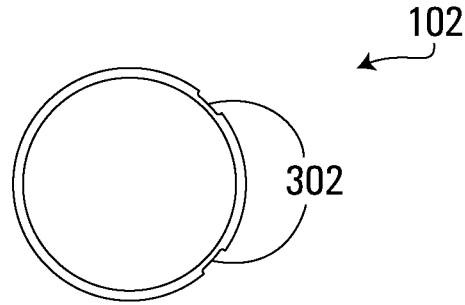

FIG. 7

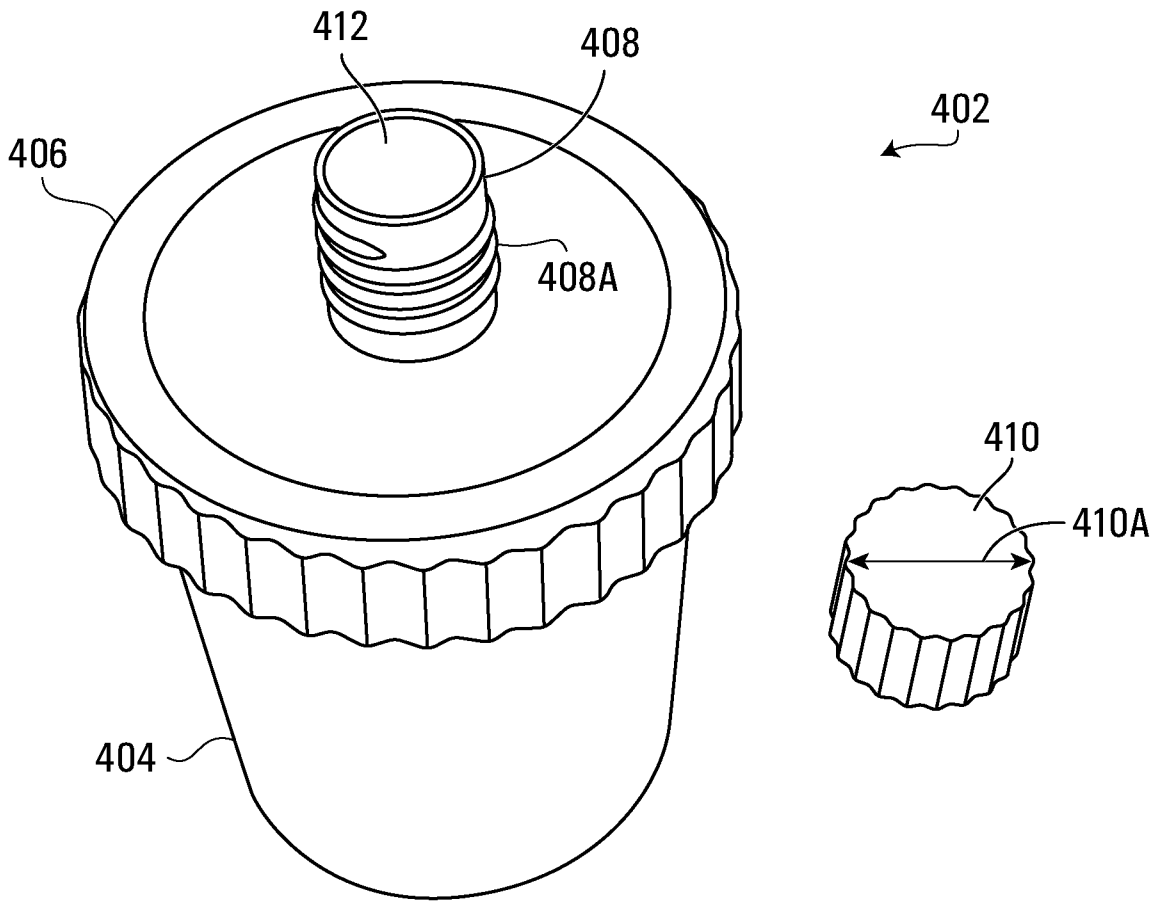

FIG. 8

+

+

7/36

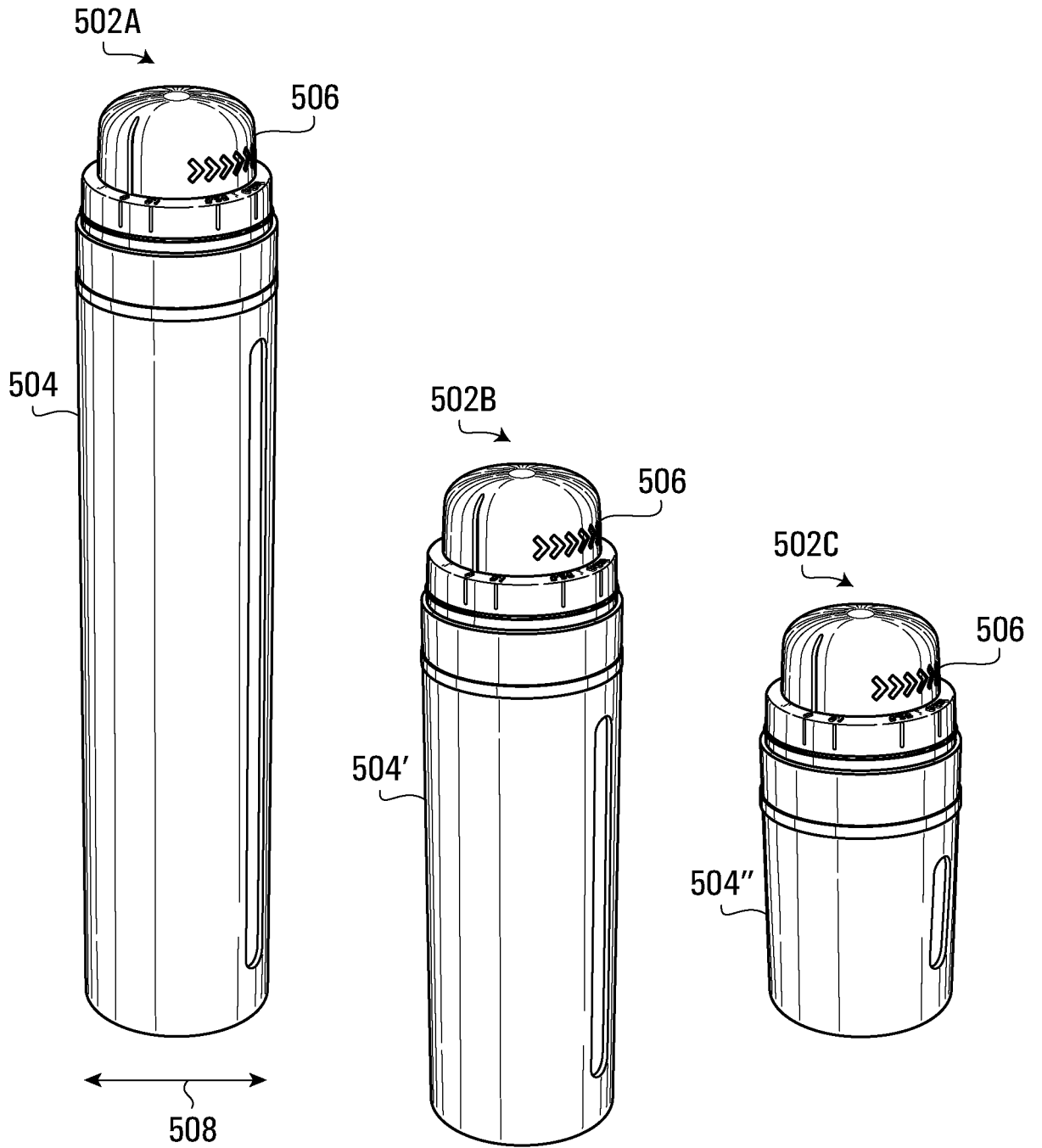

FIG. 9

+

+

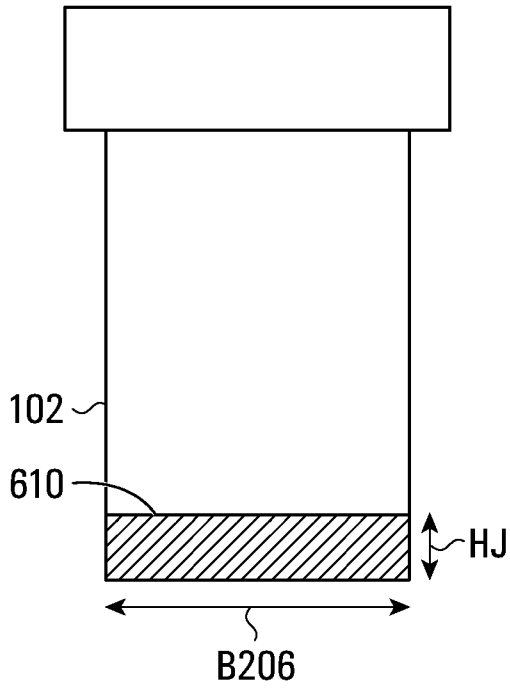

FIG. 10A

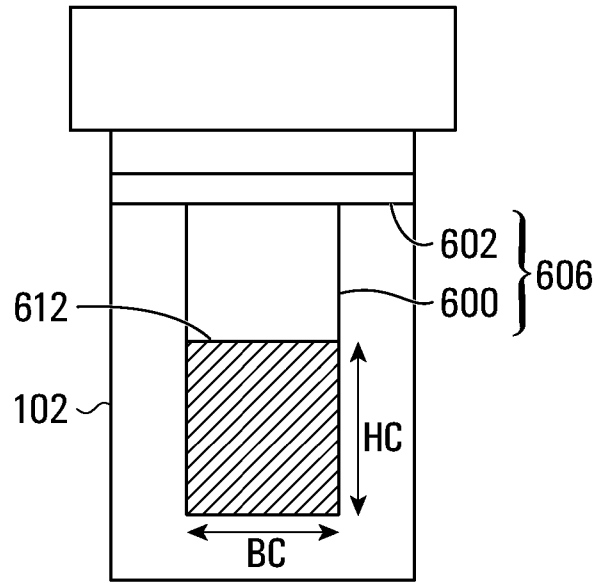

FIG. 10B

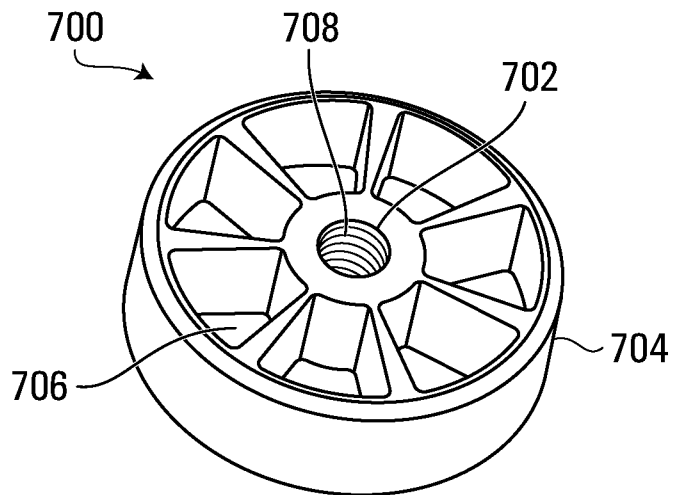

FIG. 11

+

+

9/36

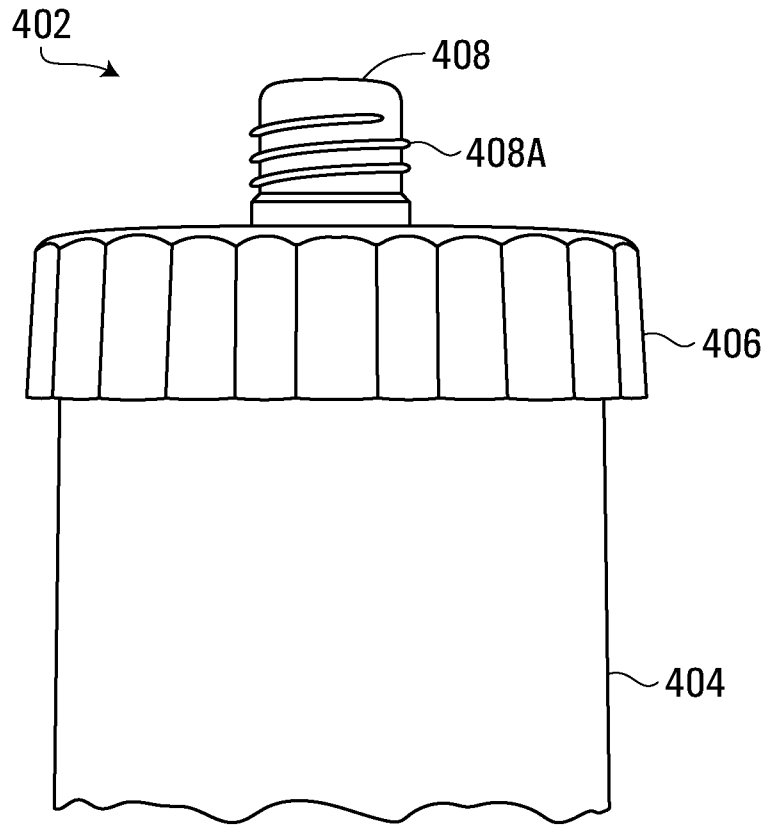

FIG. 12

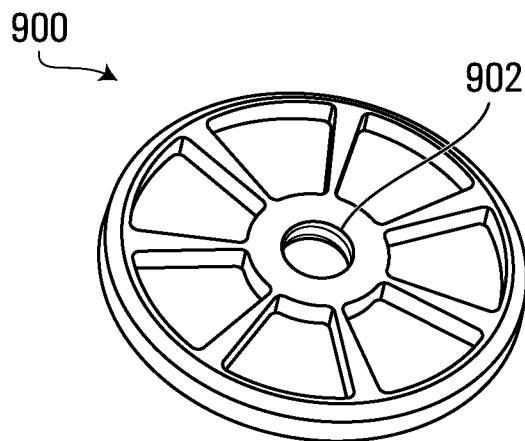

FIG. 13

+

+

10/36

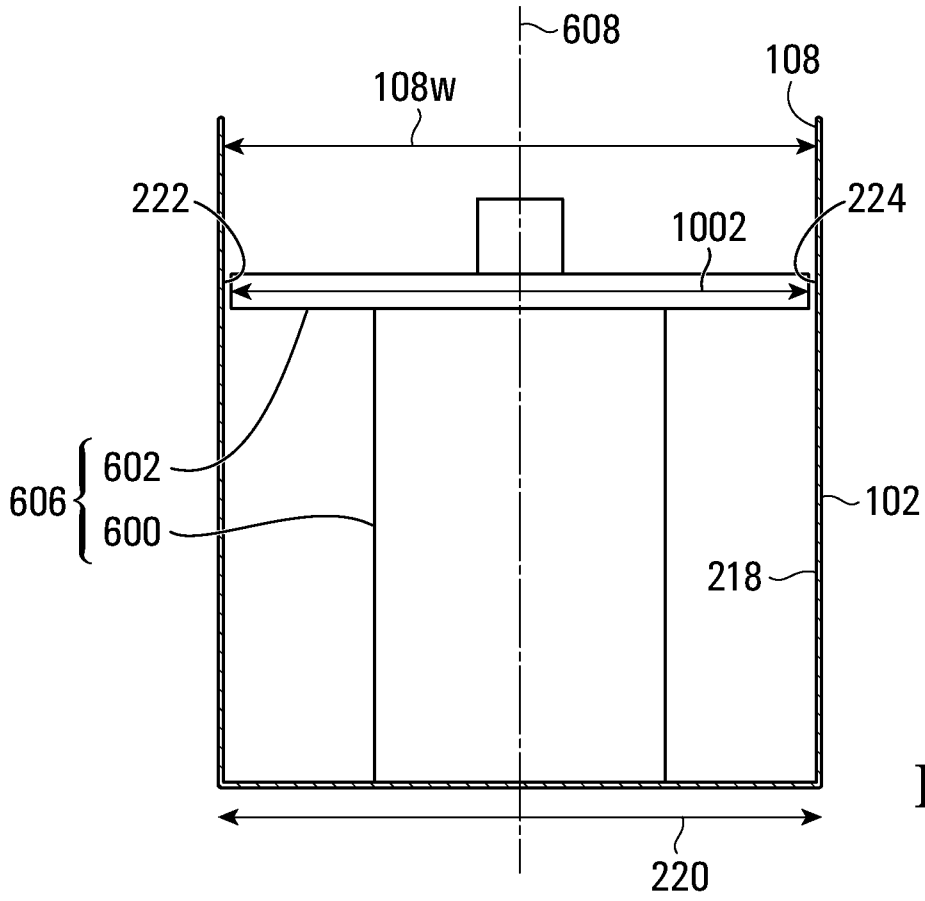

FIG. 14

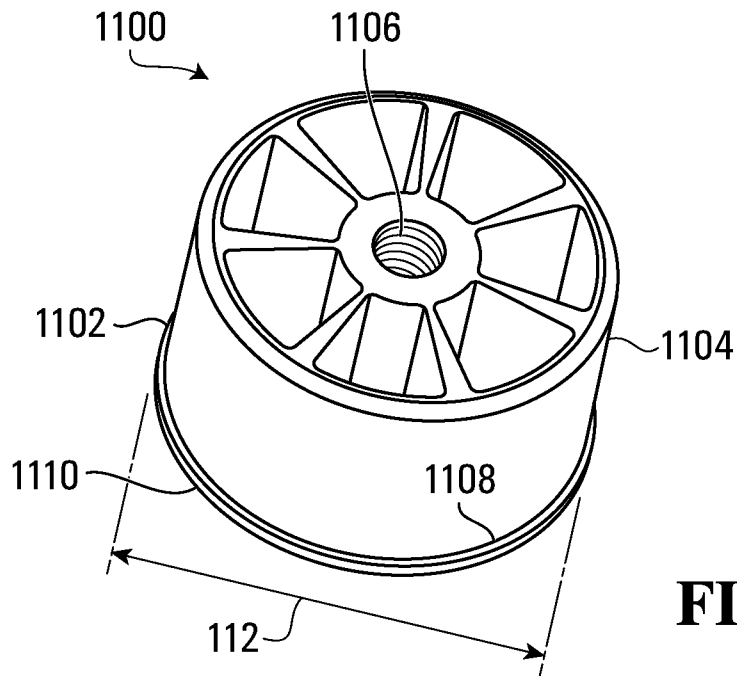

FIG. 15

+

+

11/36

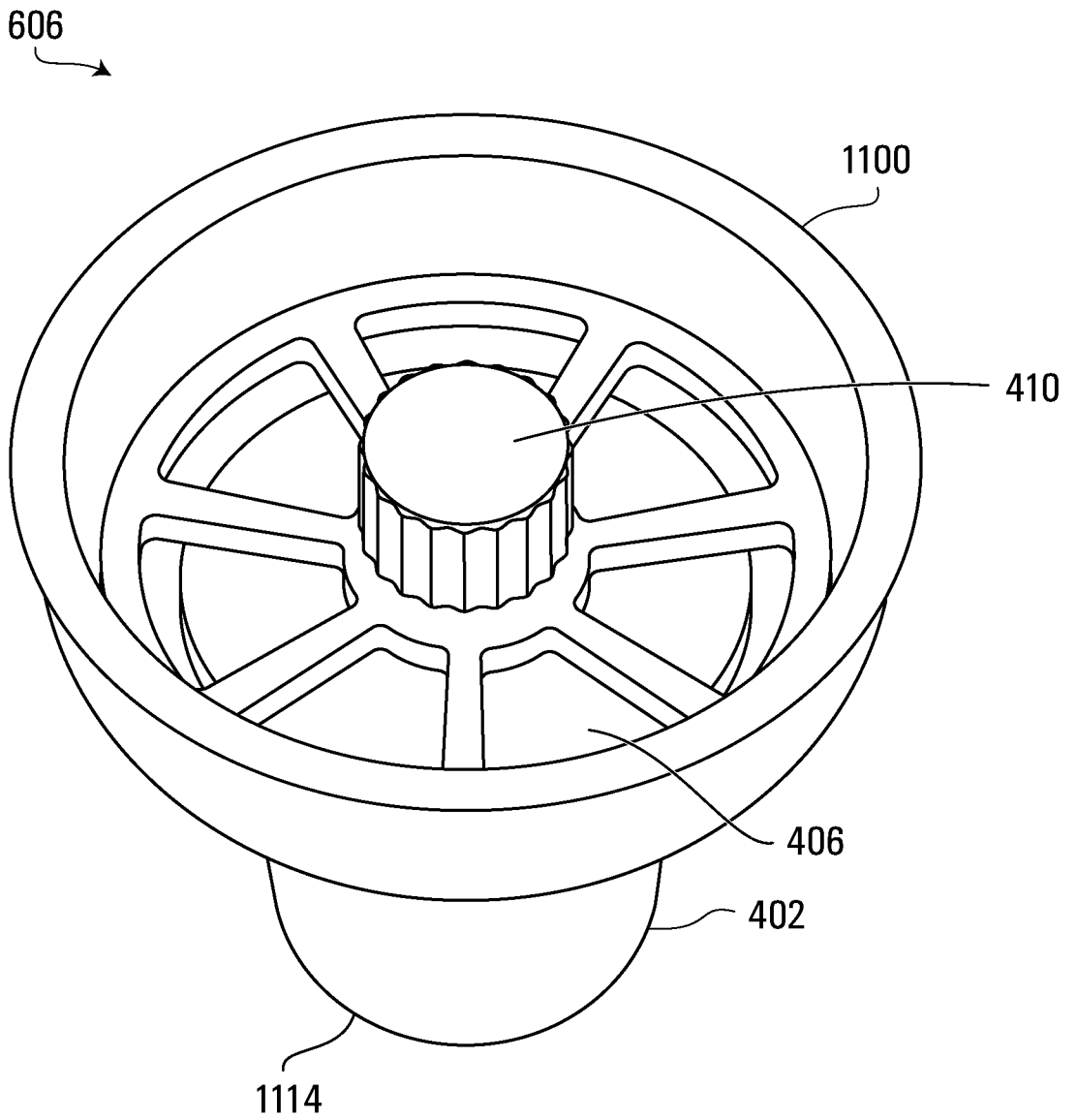

FIG. 16

+

+

12/36

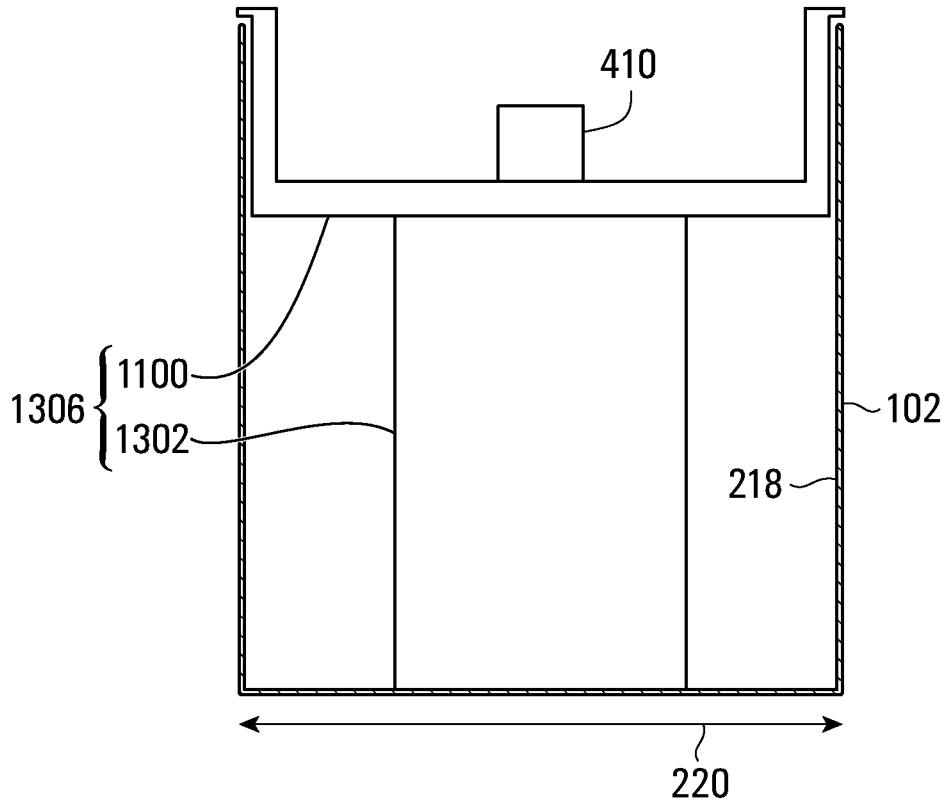

FIG. 17

+

+

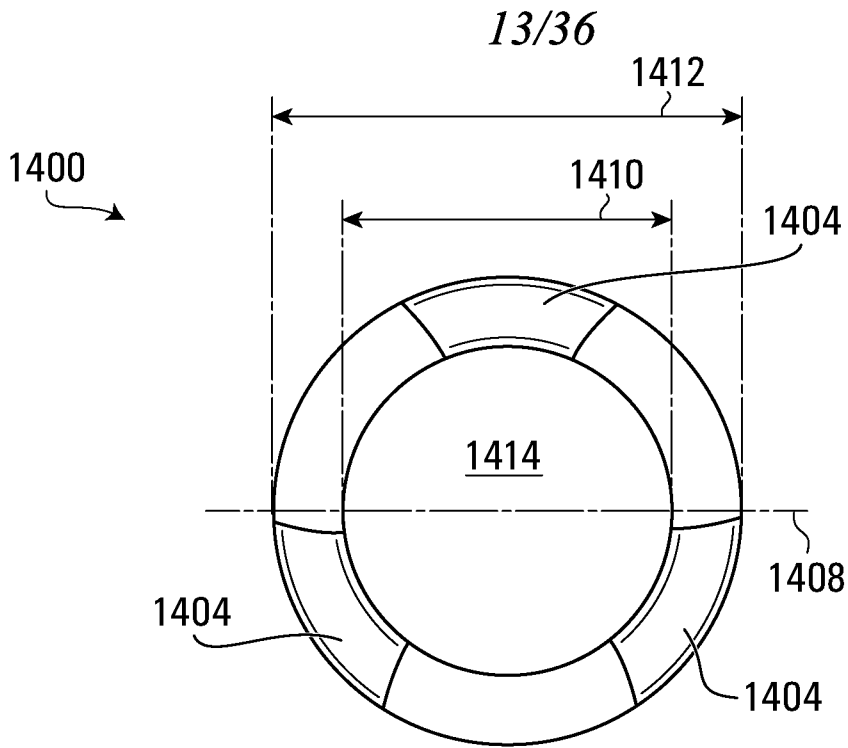

FIG. 18A

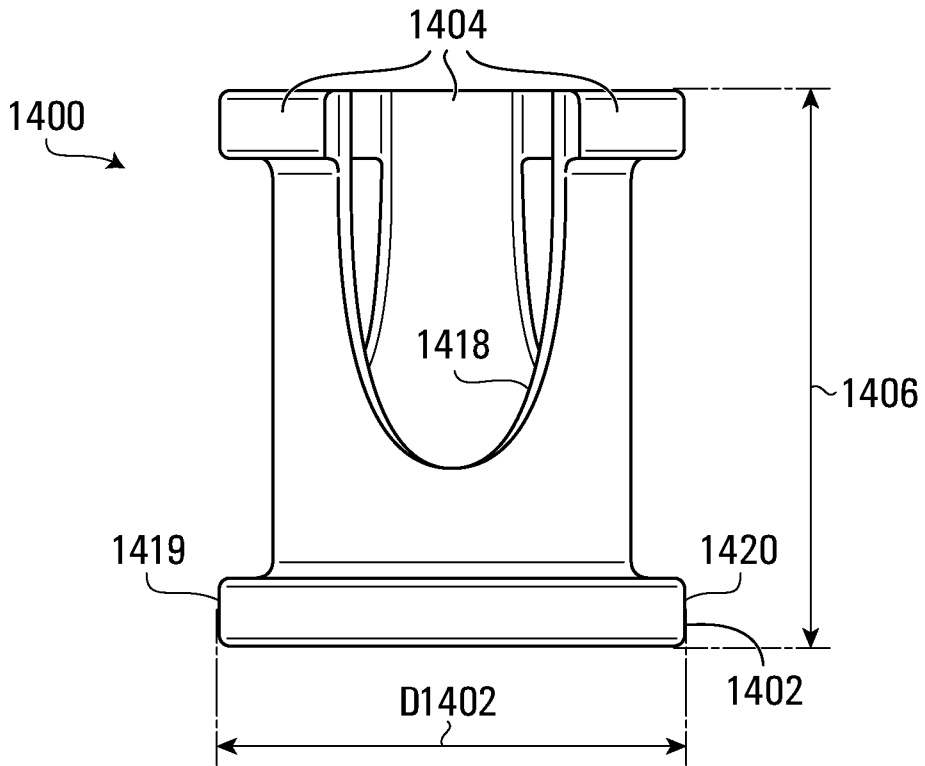

FIG. 18B

+

+

14/36

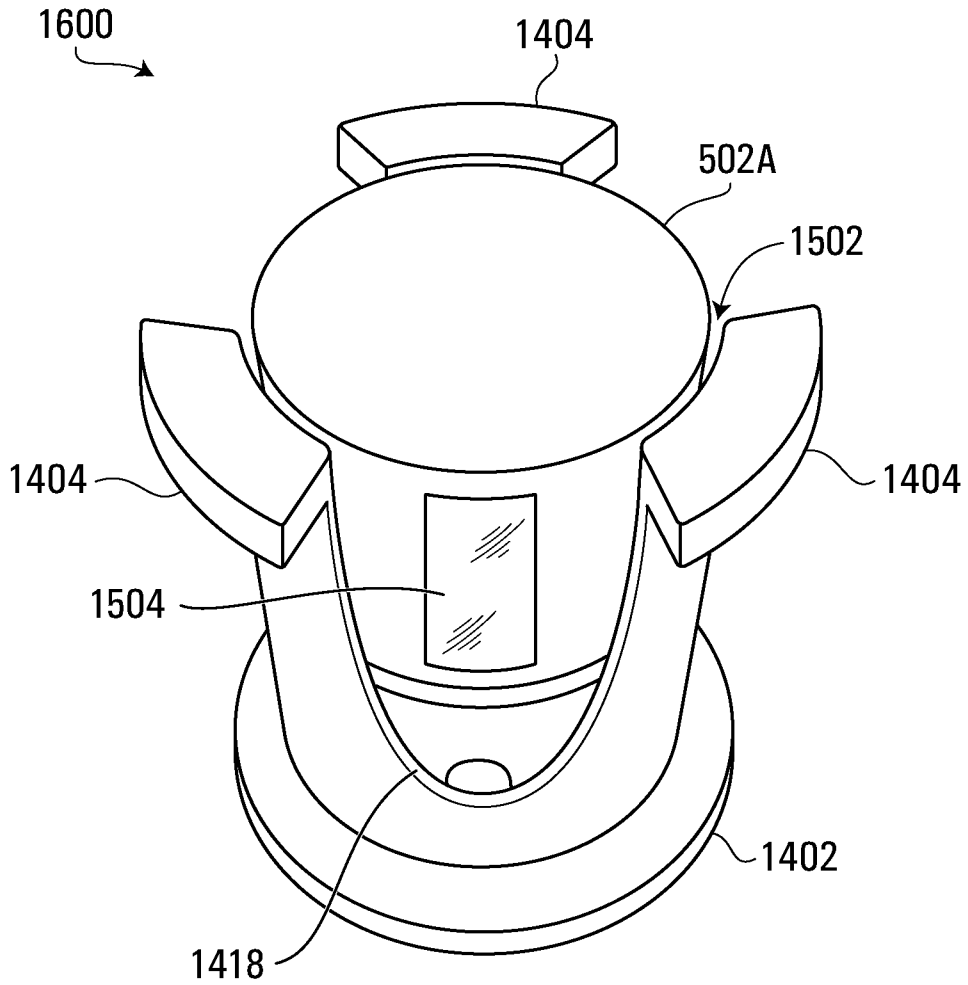
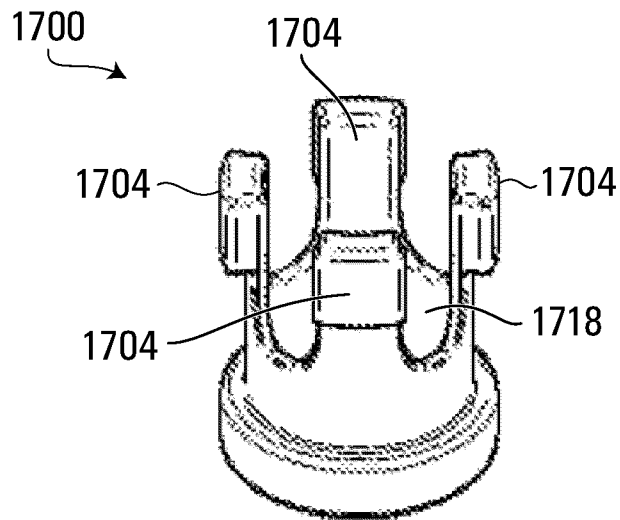
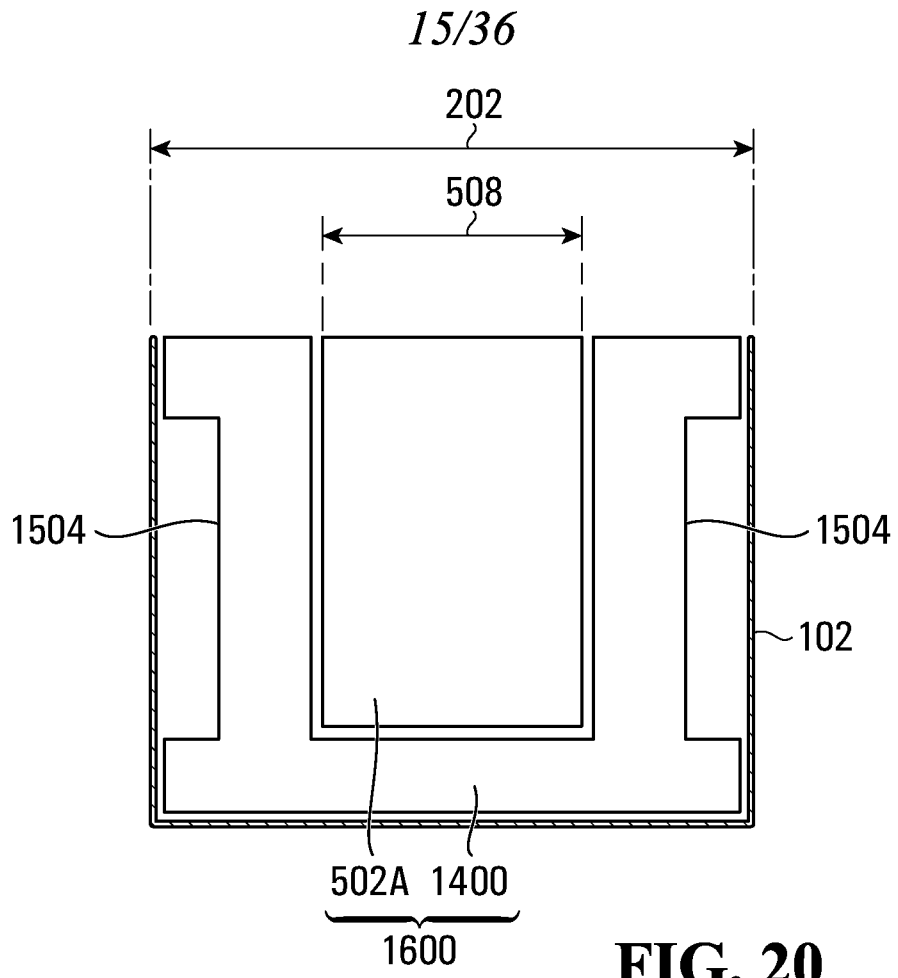

FIG. 19

+

+



+

+

16/36

2100

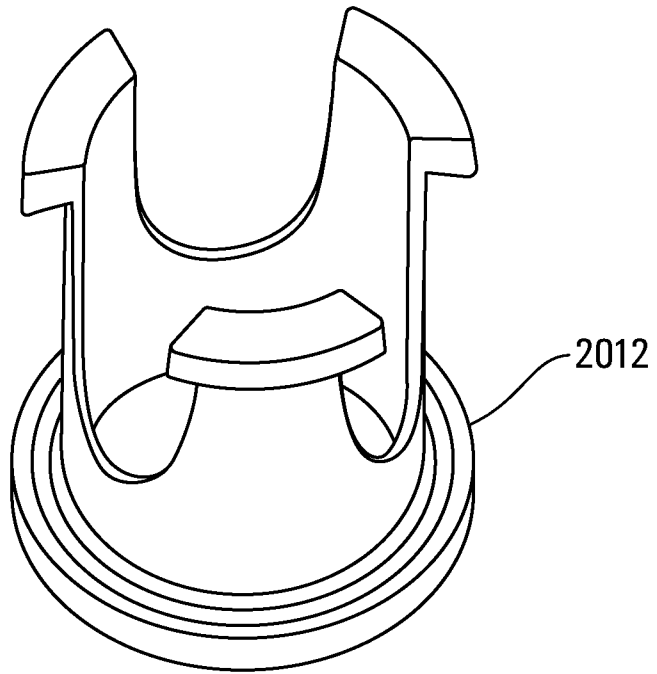

FIG. 22

+

+

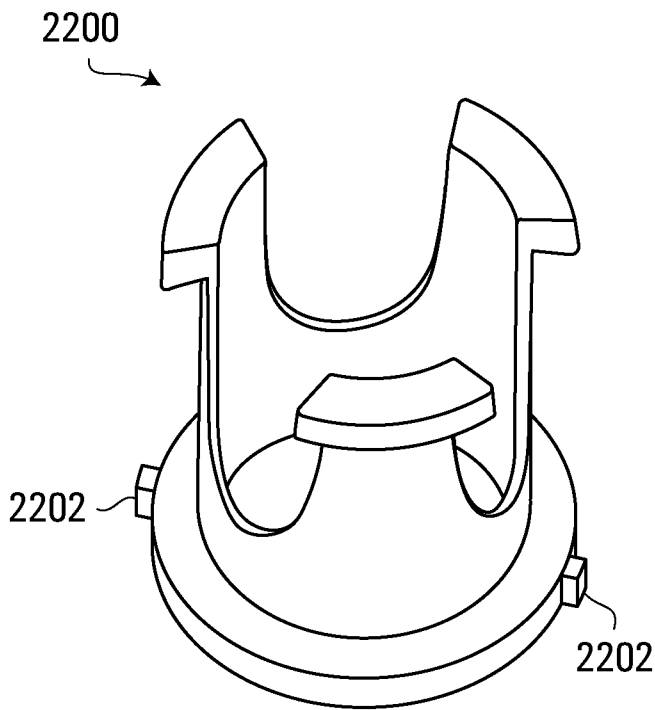

FIG. 23A

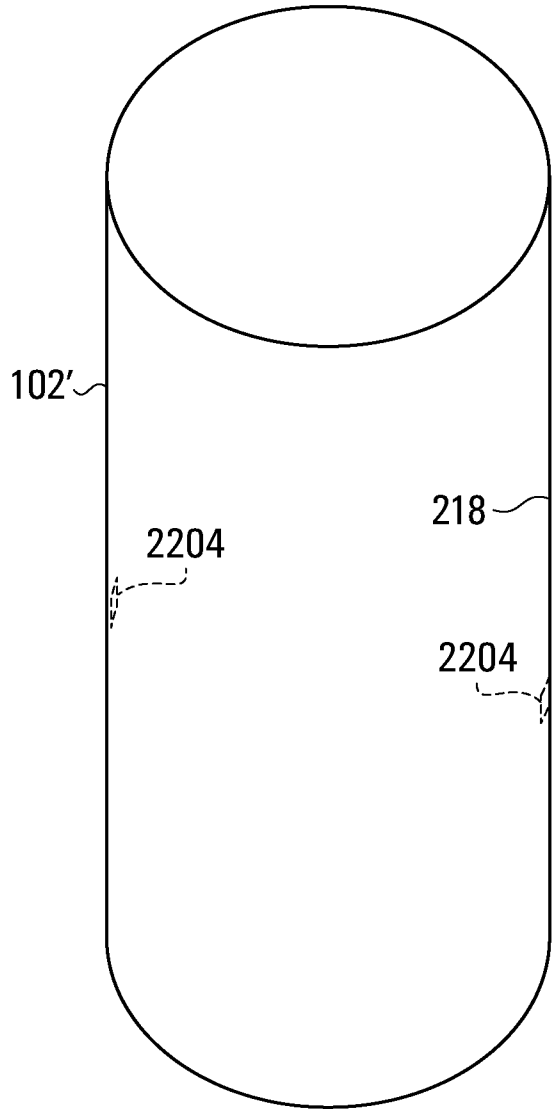

FIG. 23B

+

+

18/36

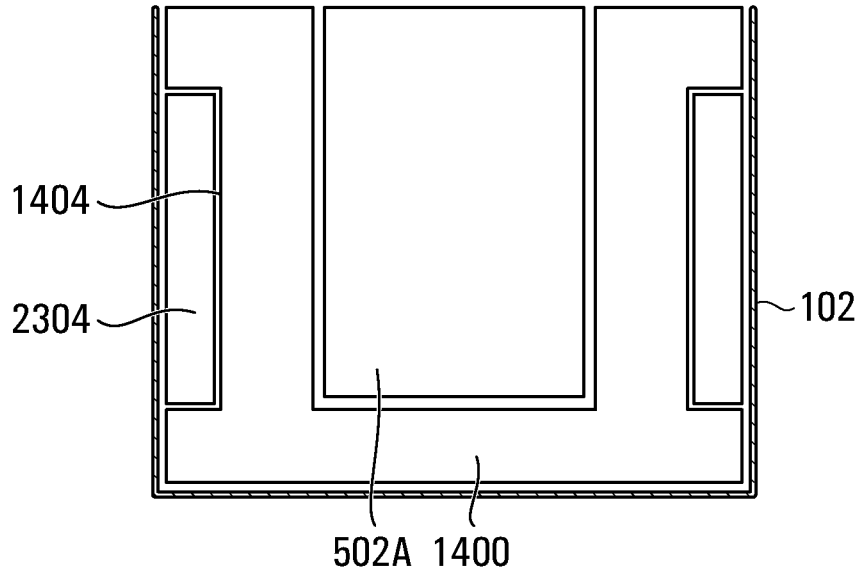

FIG. 24

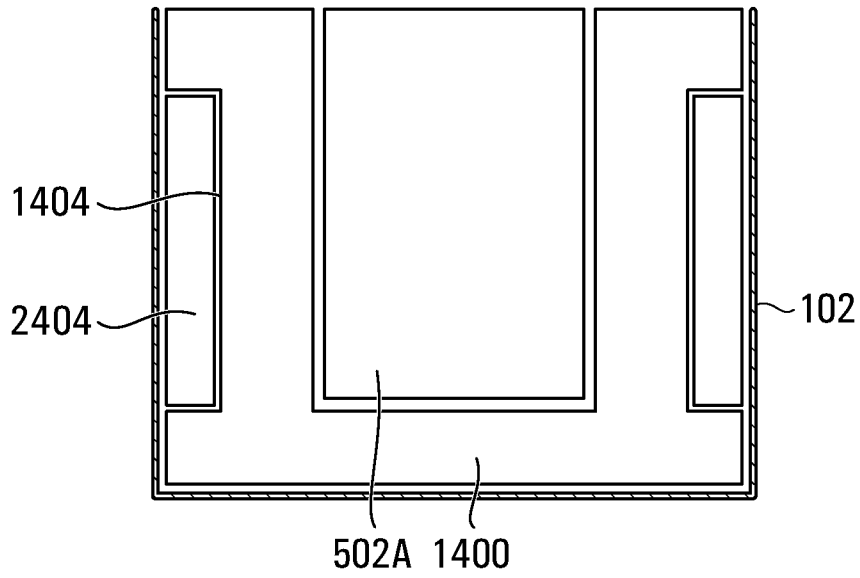

FIG. 25

+

+

19/36

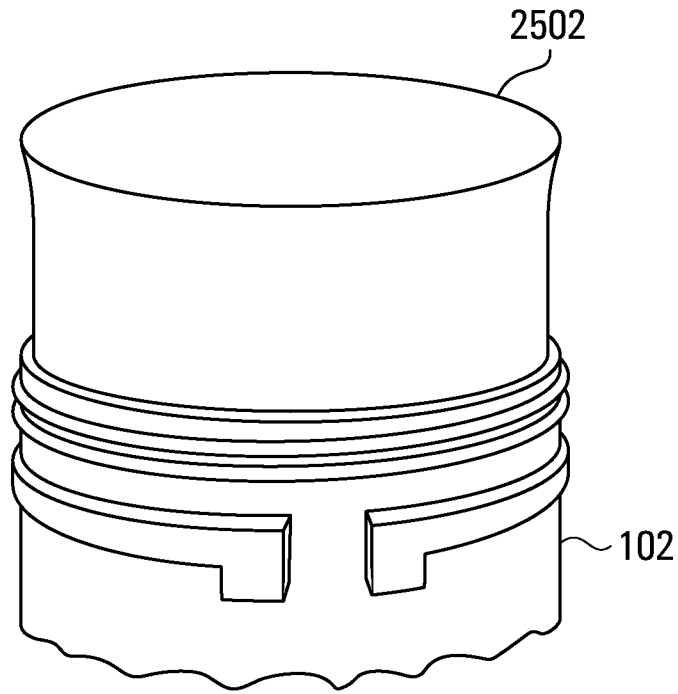

FIG. 26

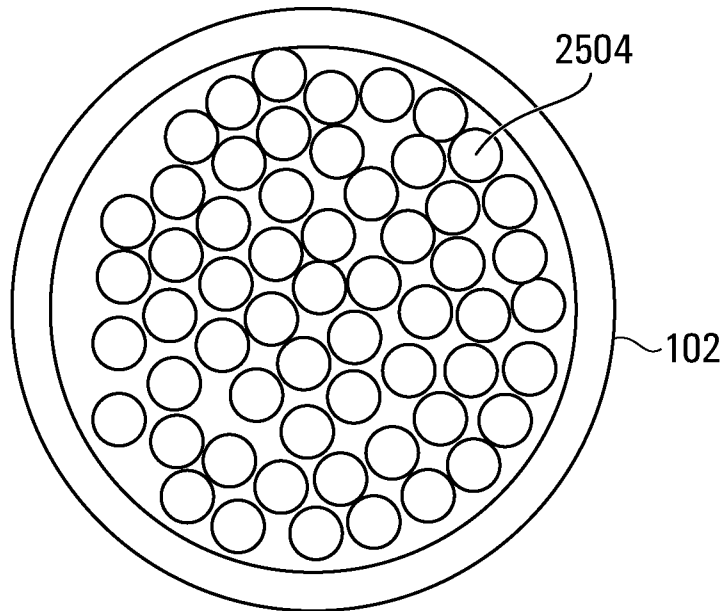

FIG. 27

+

+

20/36

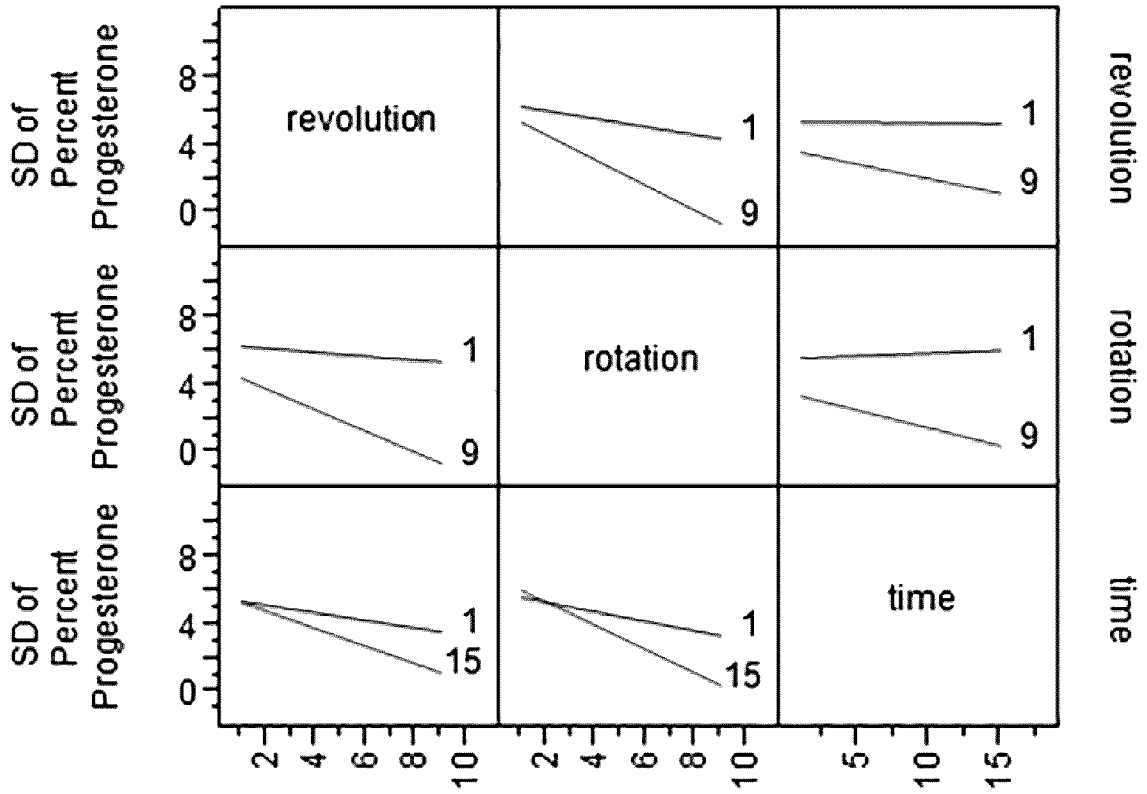

FIG. 28

+

+

21/36

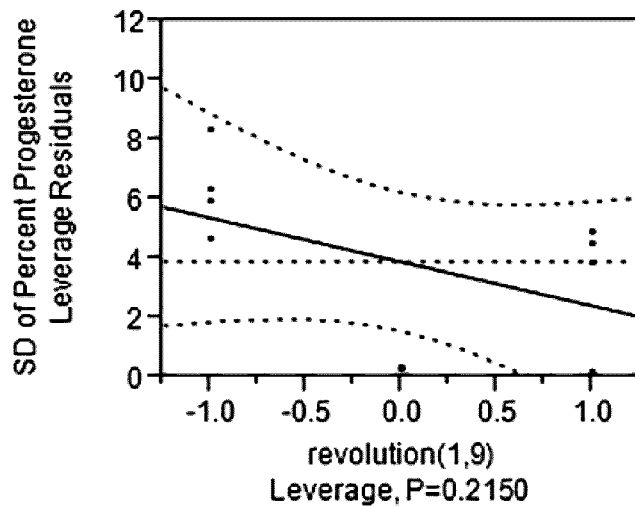
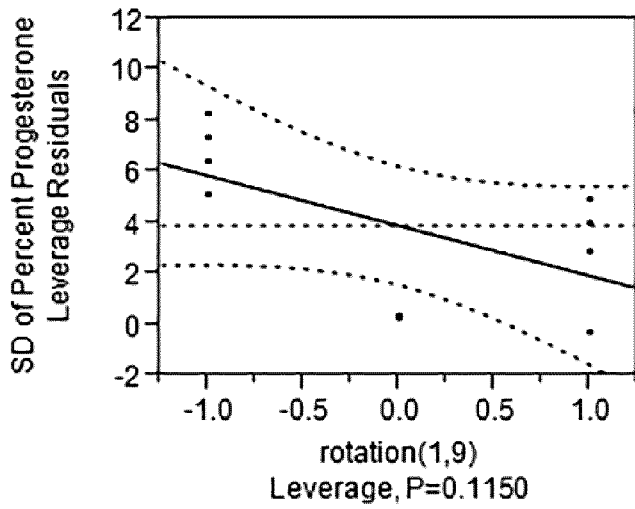
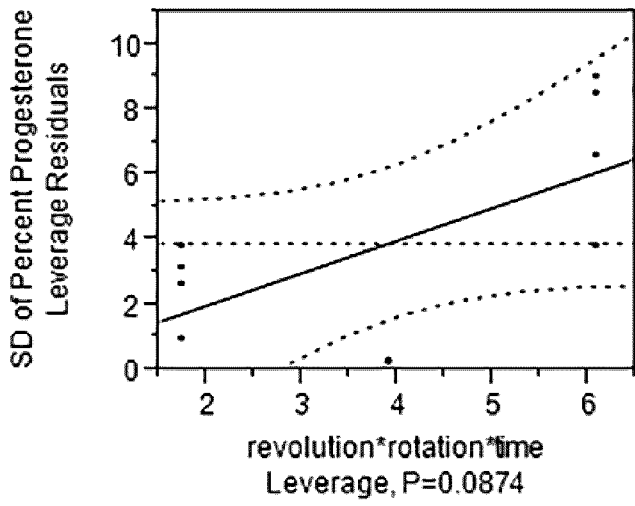

FIG. 29

+

+

22/36

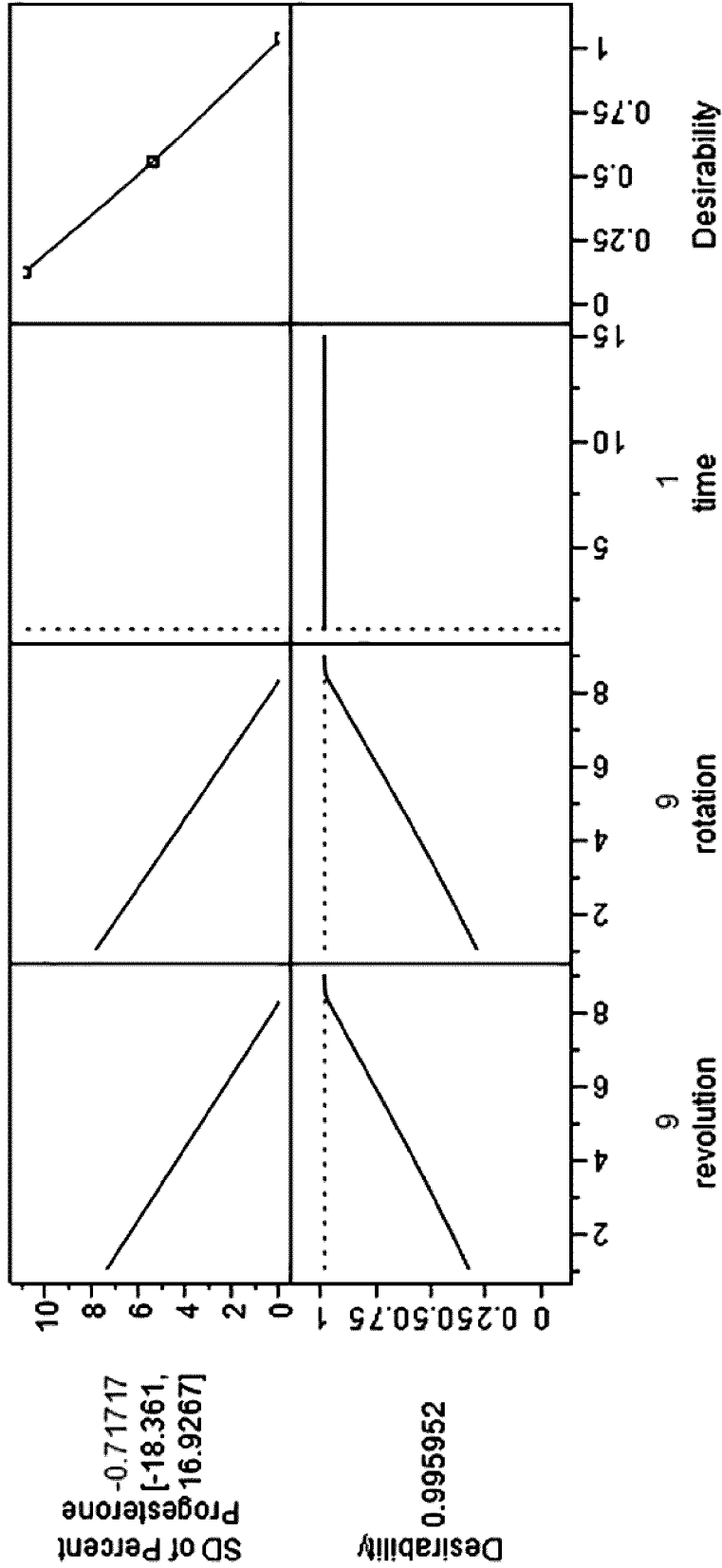
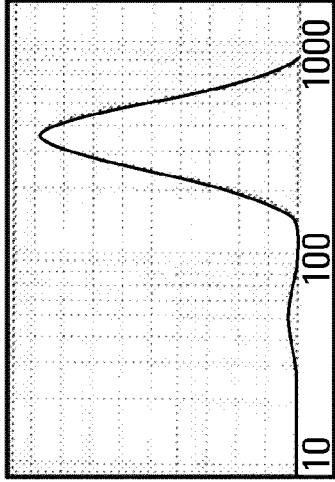

FIG. 30

+

+



A

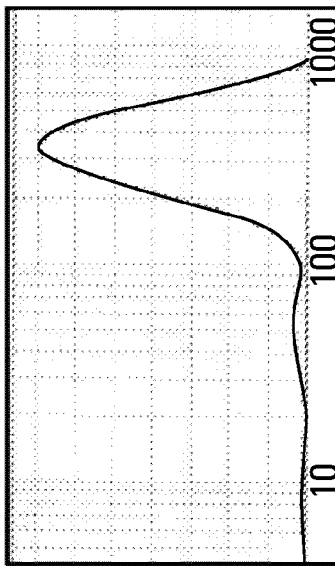

B

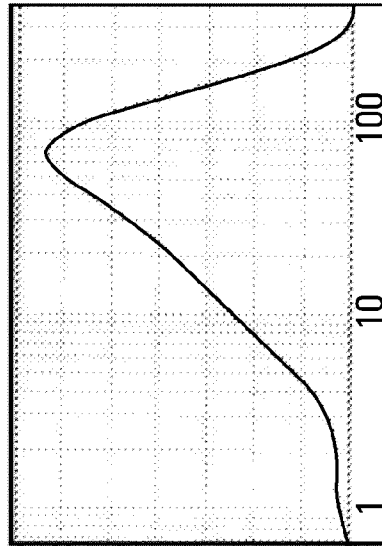

C

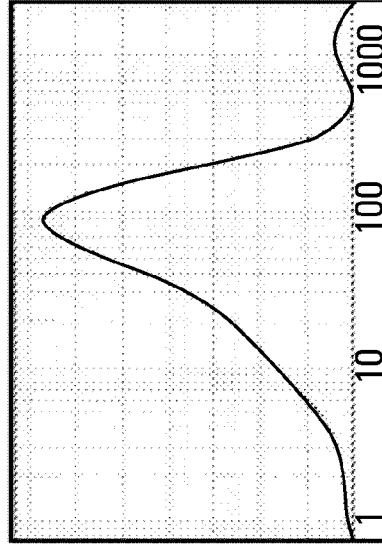

D

FIG. 31

+

+

24/36

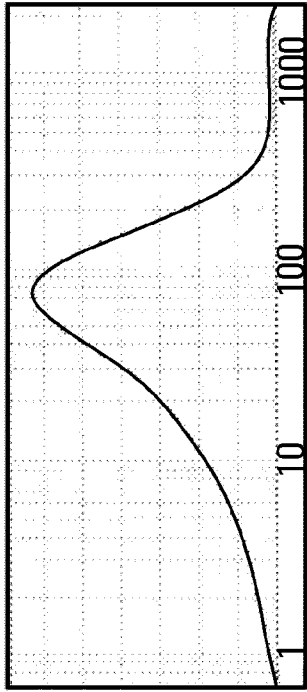

A

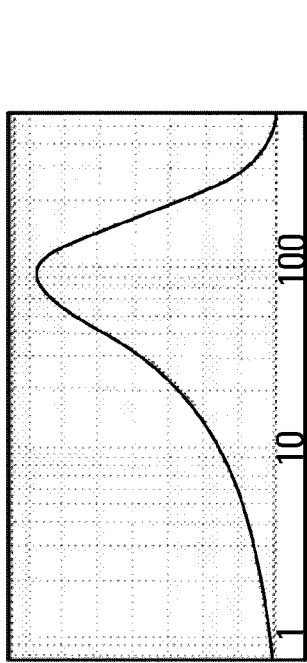

B

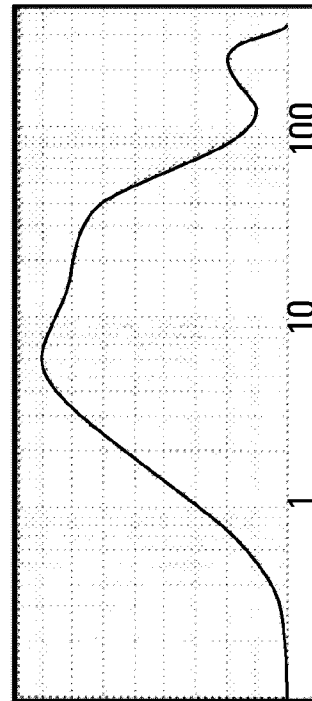

C

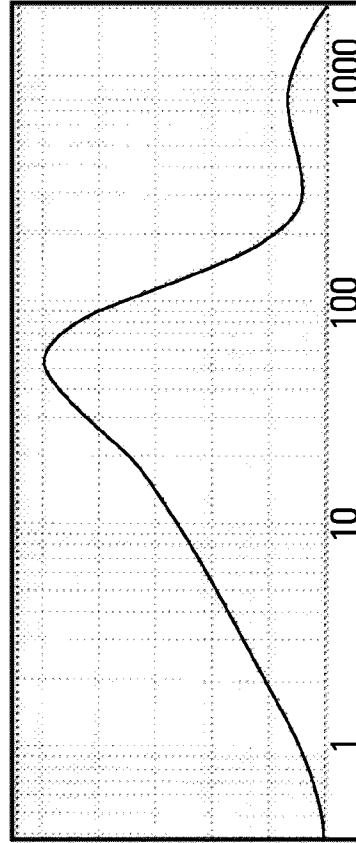

D

FIG. 32

+

+

25/36



FIG. 33

+

+

26/36

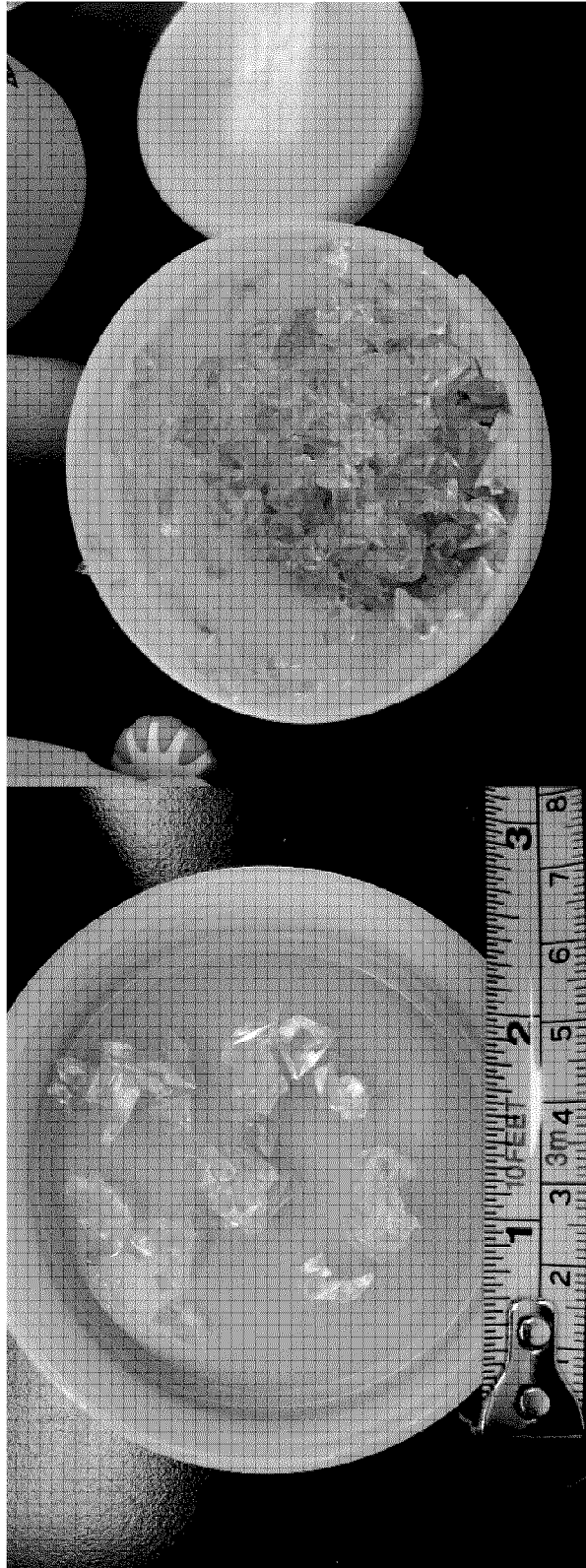

FIG. 34

+

+

27/36

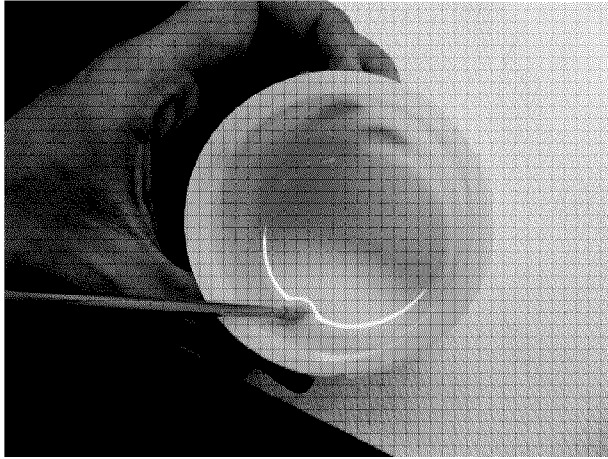

FIG. 35A

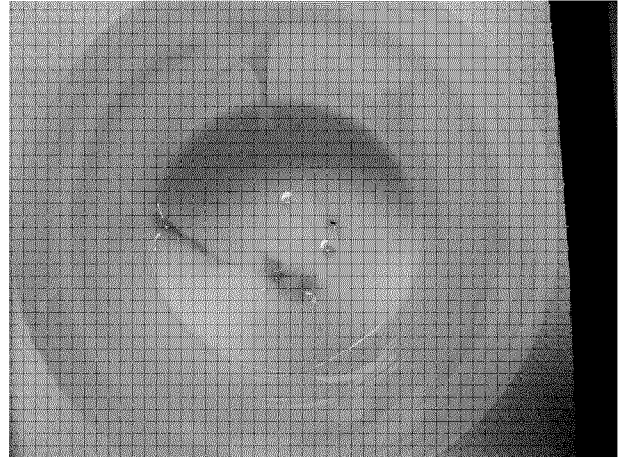

FIG. 35B

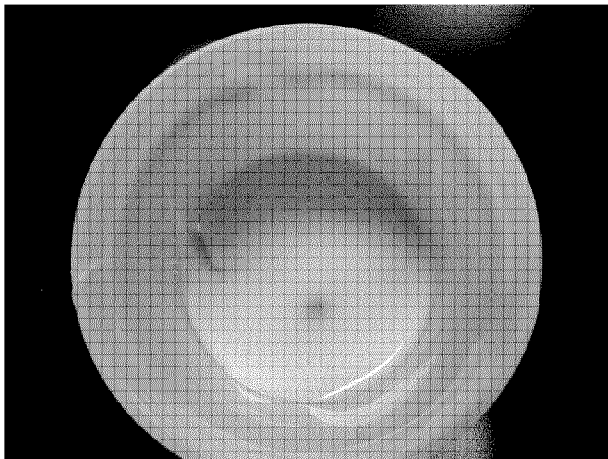

FIG. 35C

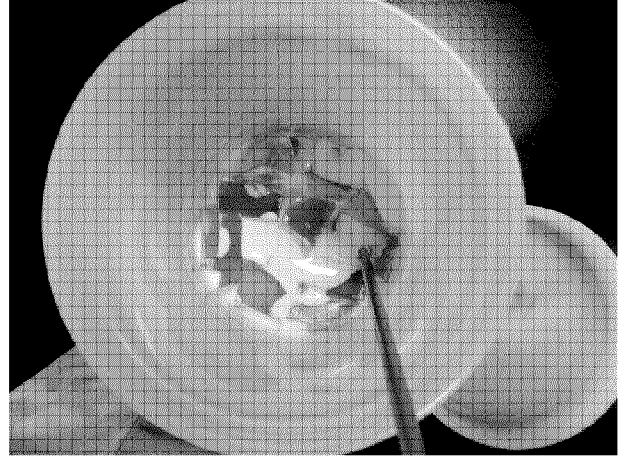

FIG. 35D

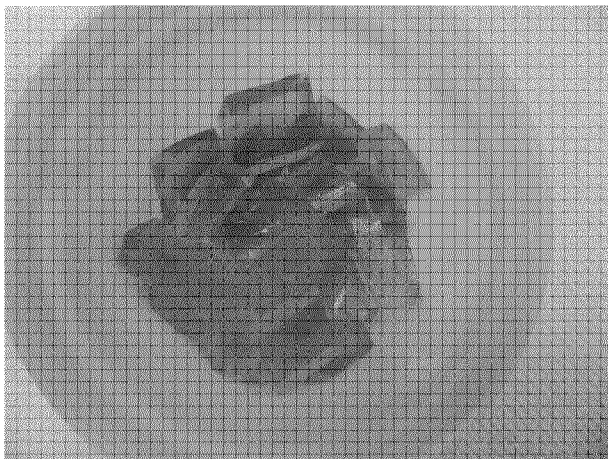

FIG. 35E

+

+

28/36

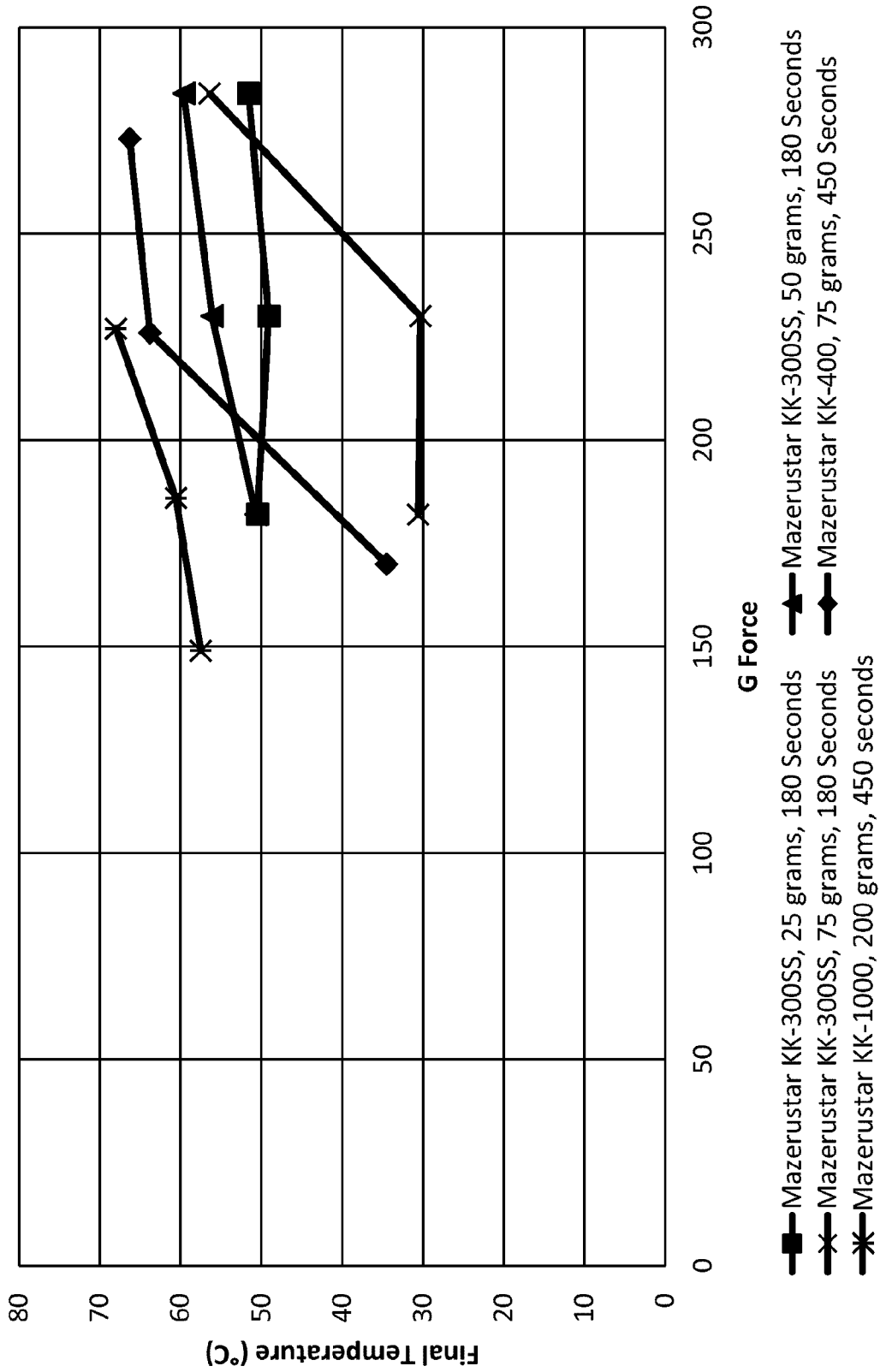

FIG. 36

+

+

29/36

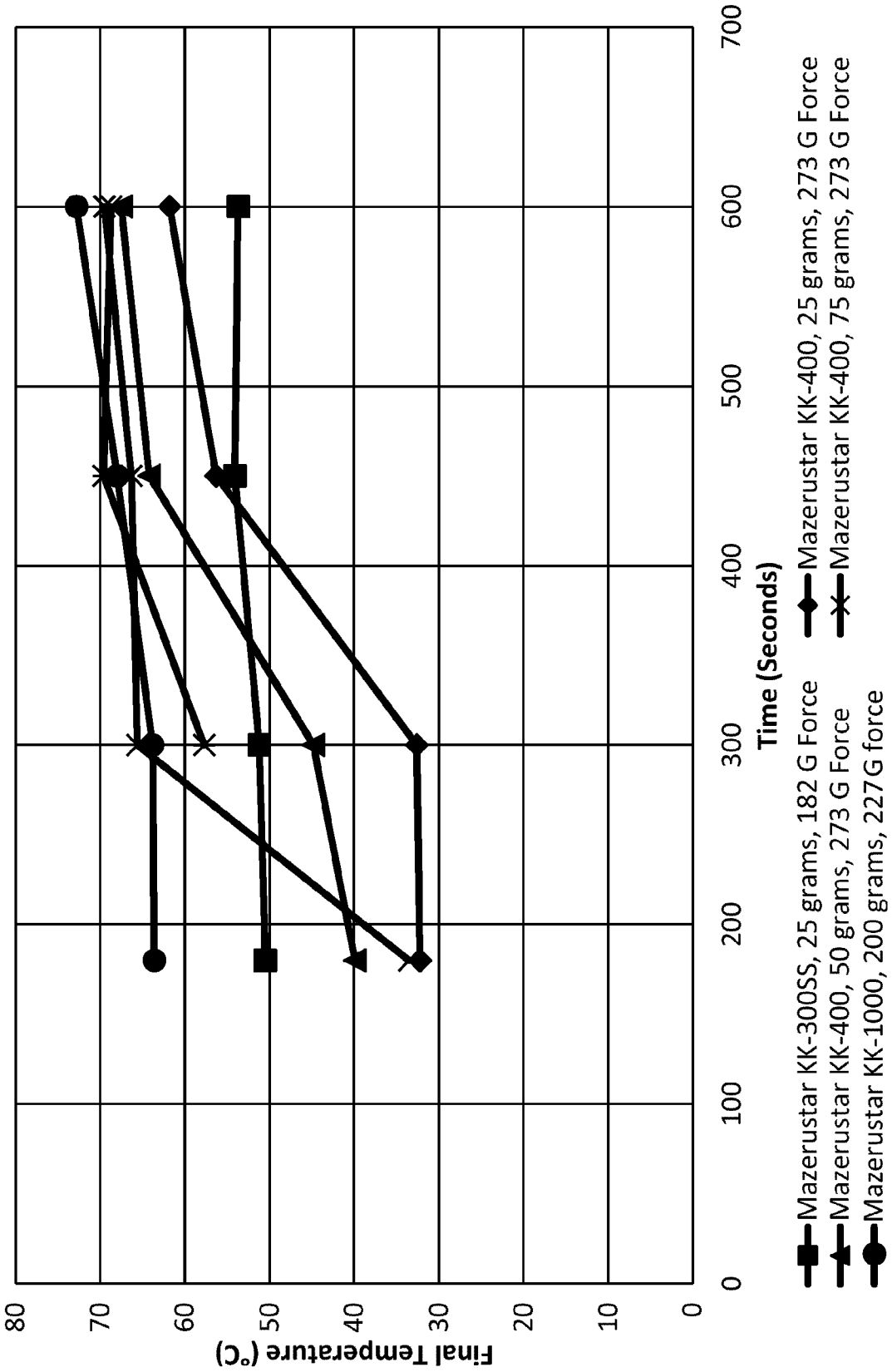

FIG. 37

+

+

30/36

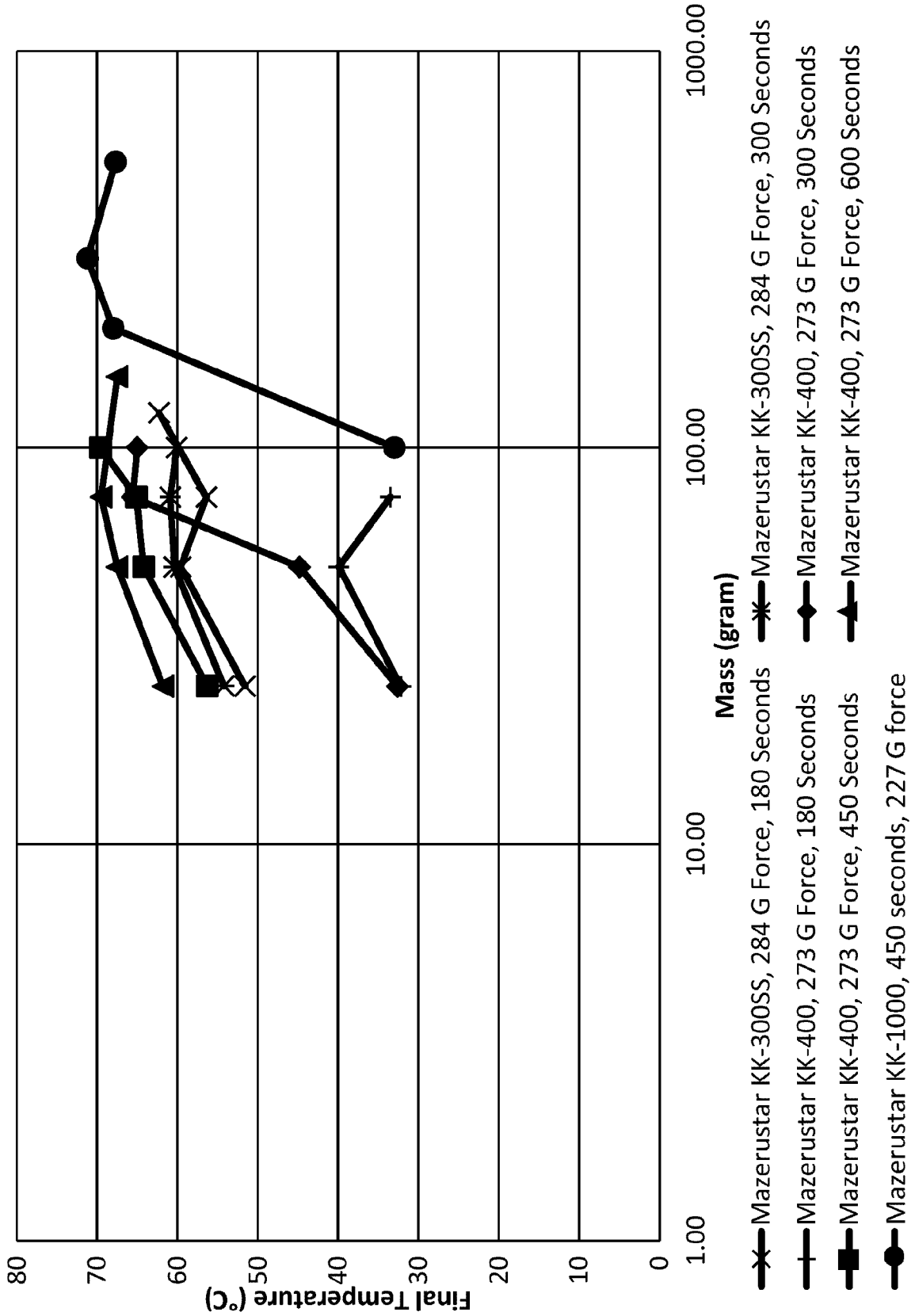

FIG. 38

+

+

31/36

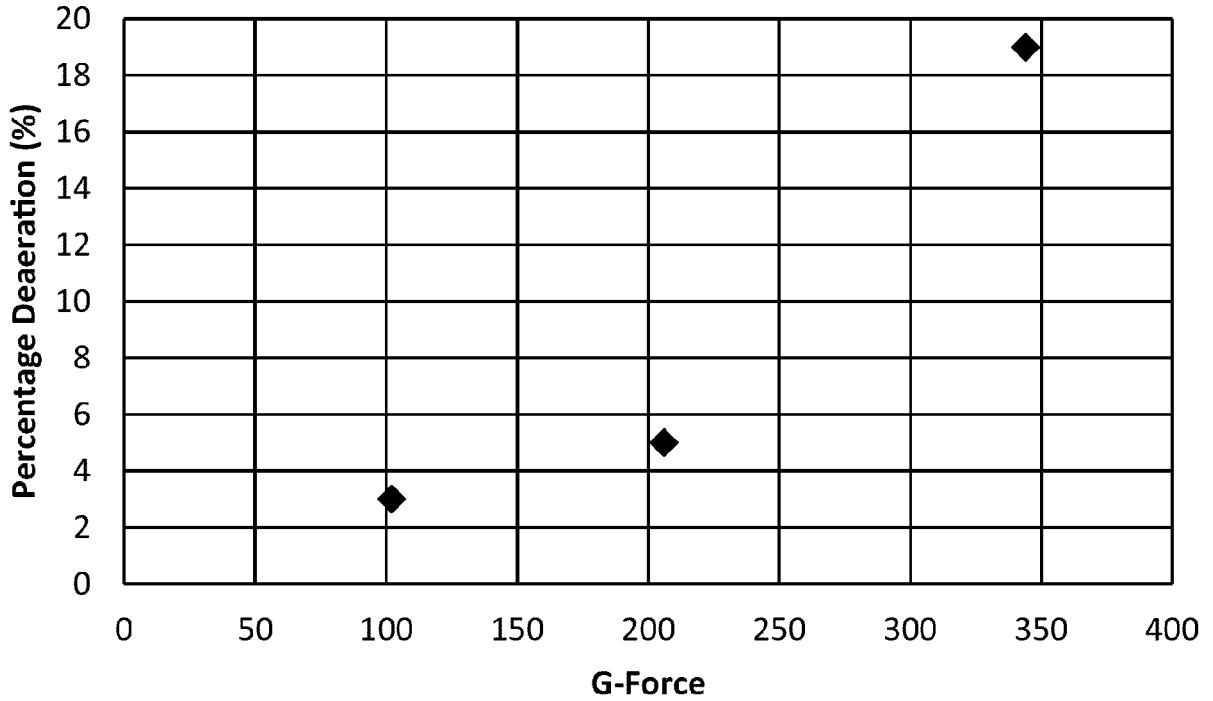

FIG. 39

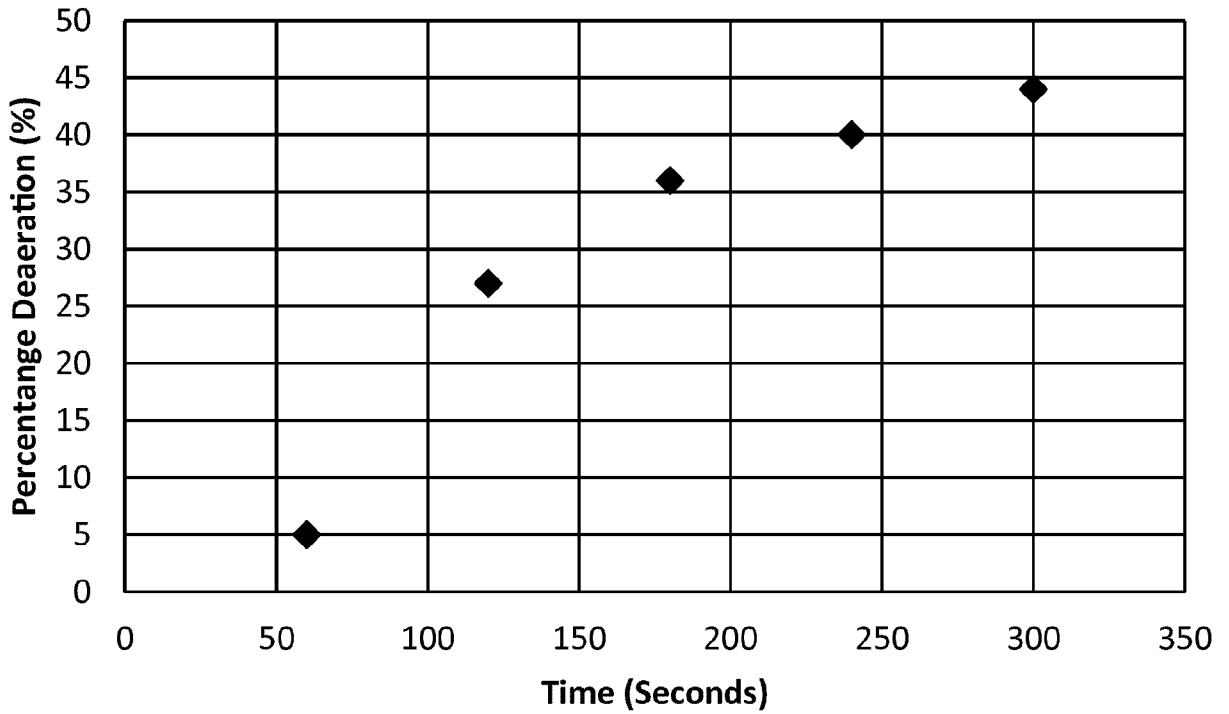

FIG. 40

+

+

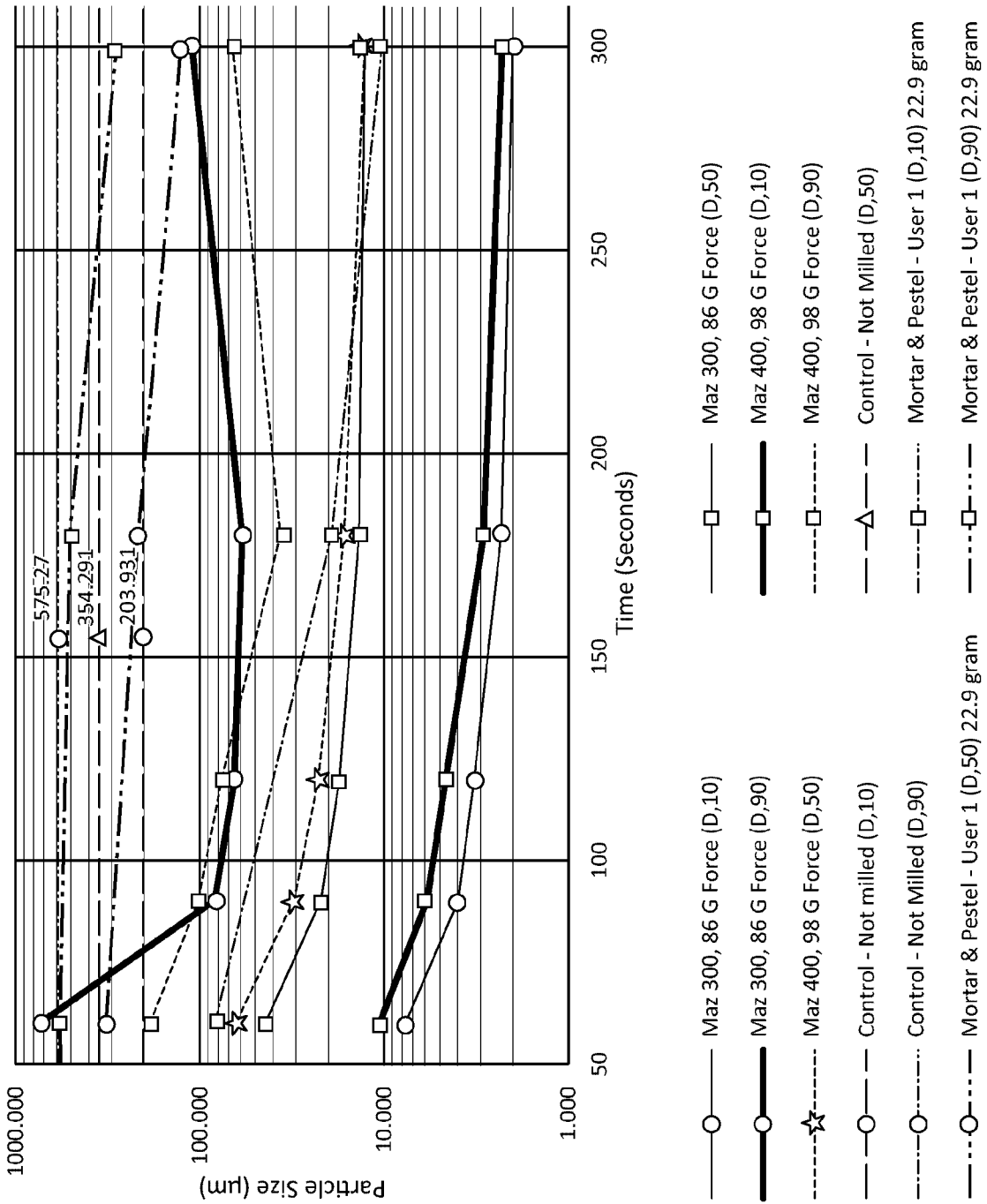

FIG. 41

+

+

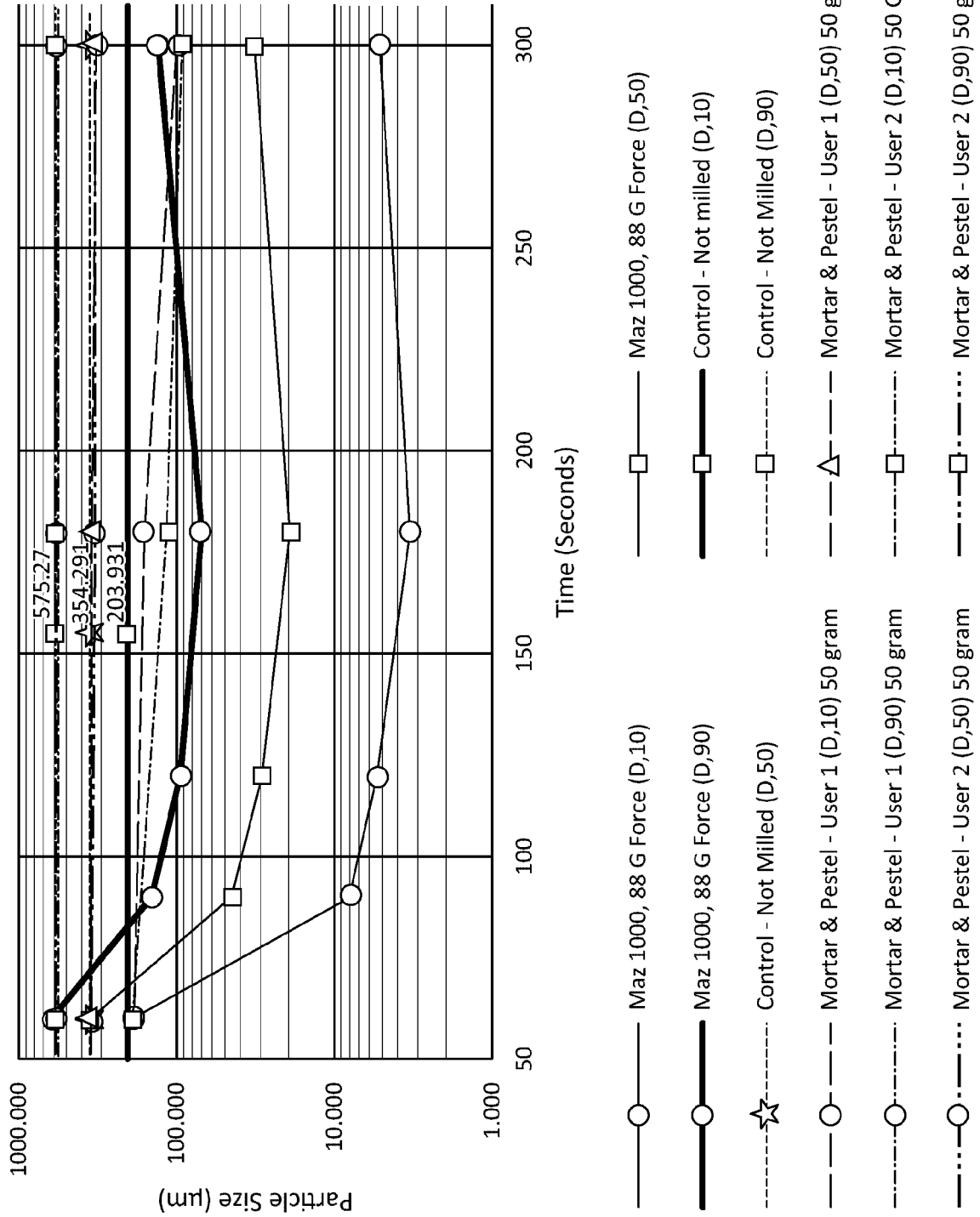

FIG. 42

+

+

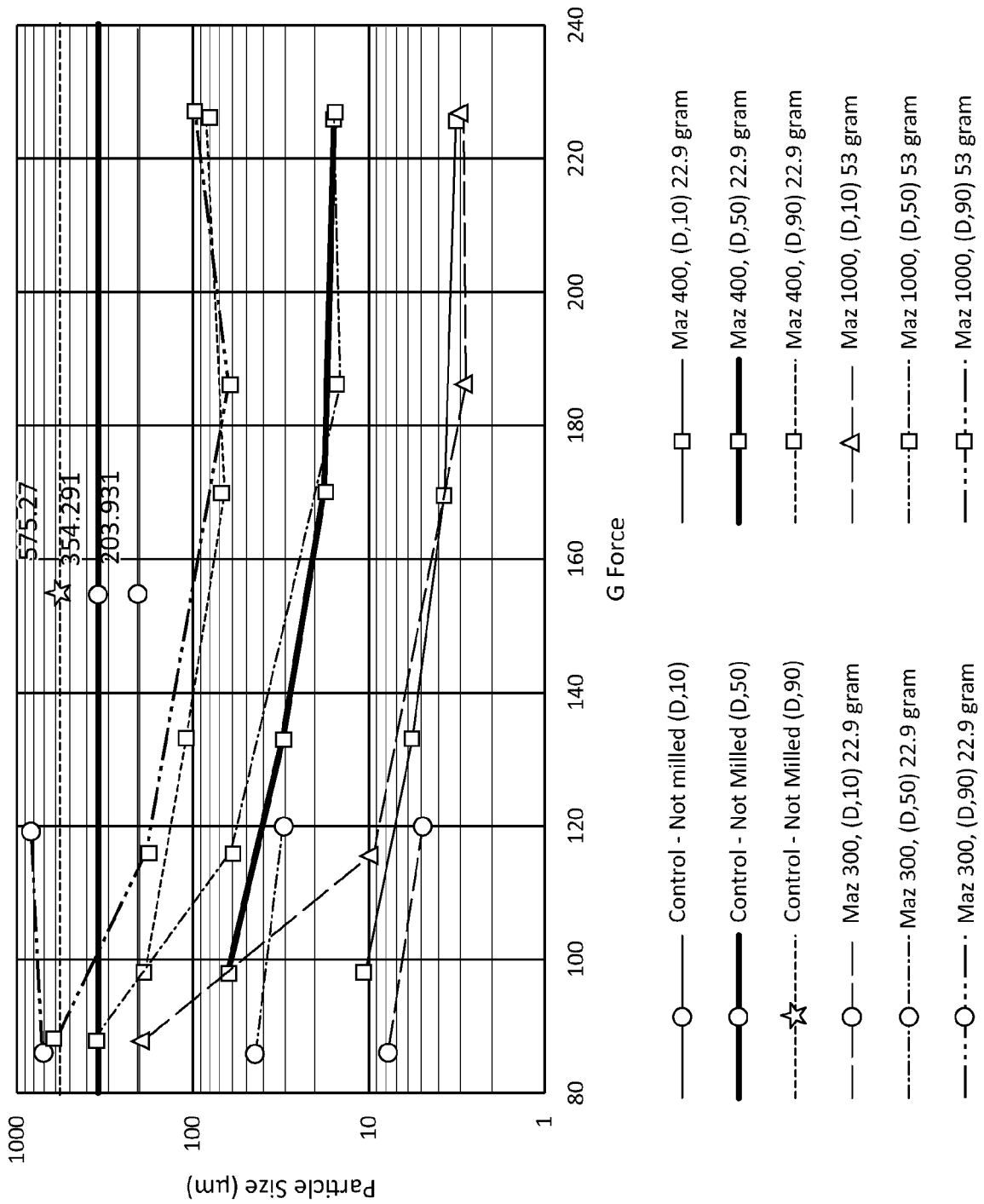

FIG. 43

+

+

35/36

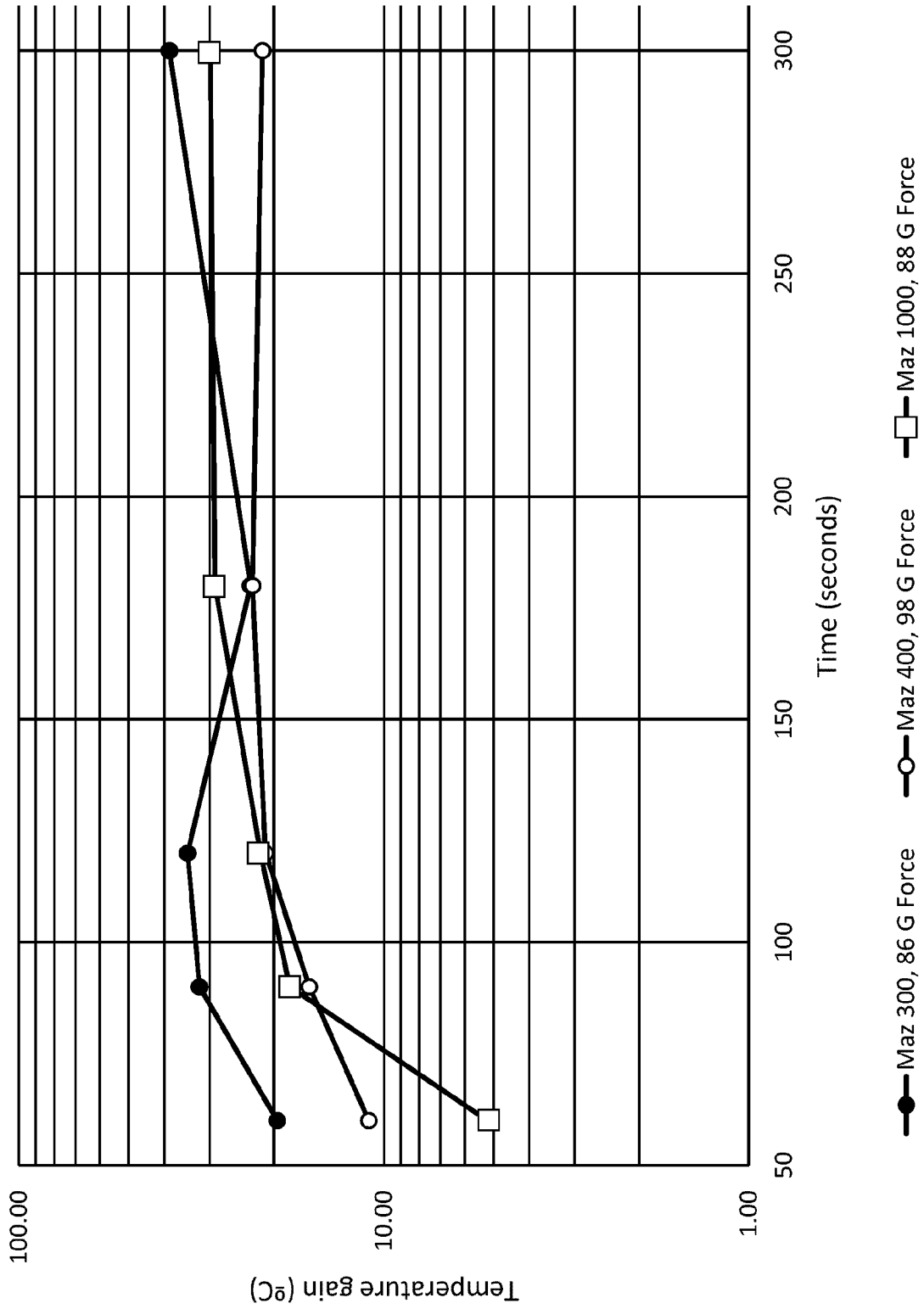

FIG. 44

+

+

36/36

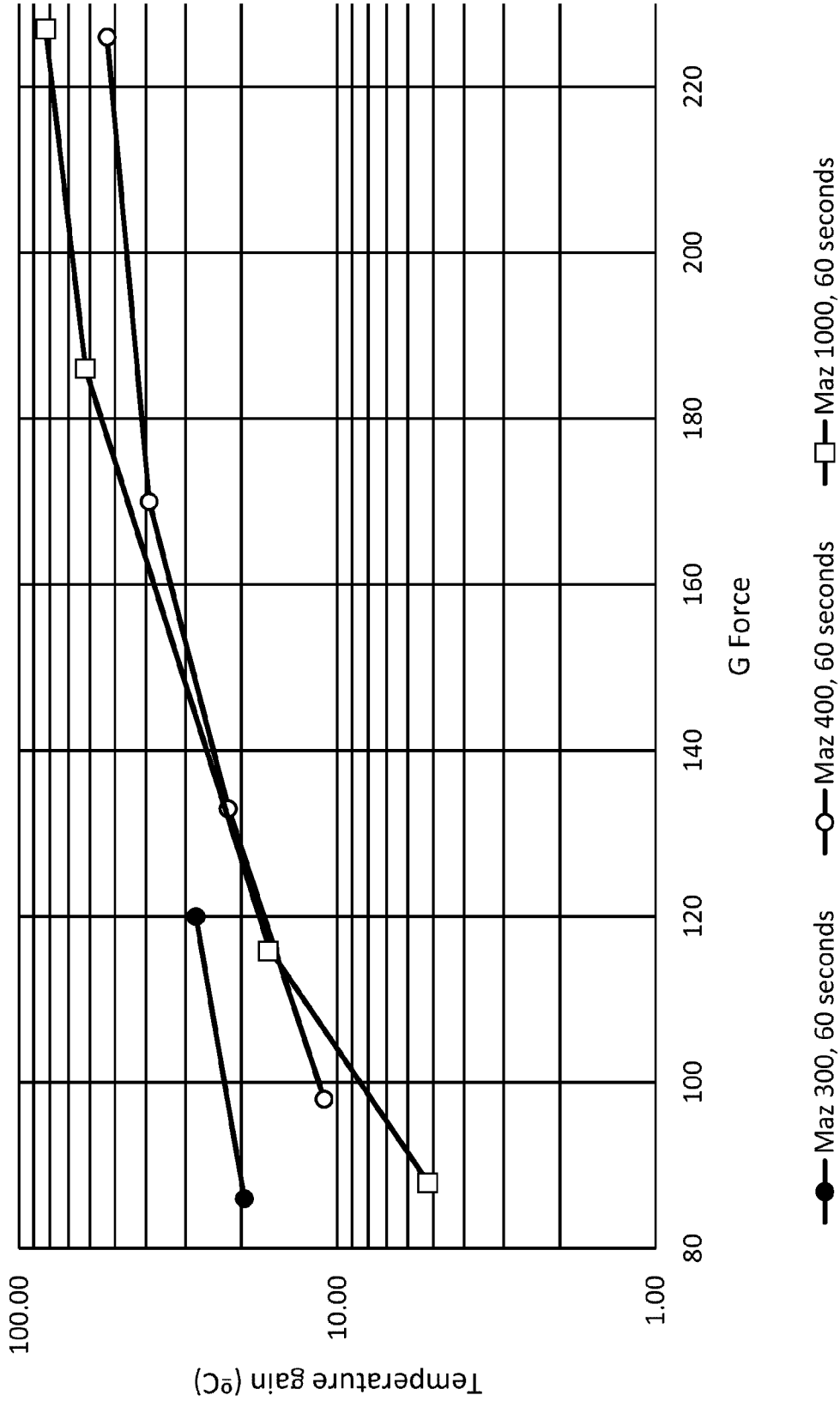

FIG. 45

+

