

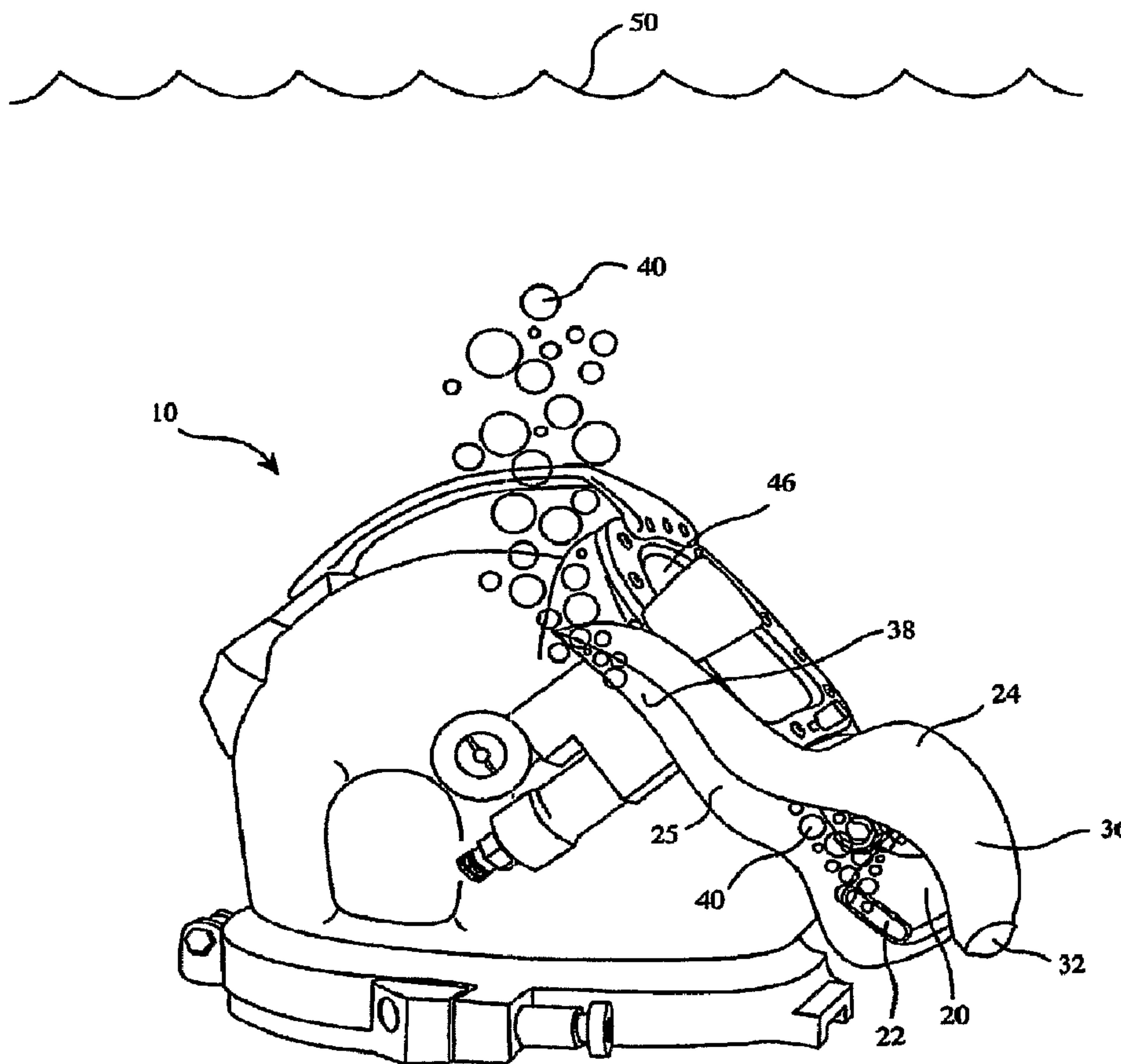

(86) Date de dépôt PCT/PCT Filing Date: 2006/09/21
 (87) Date publication PCT/PCT Publication Date: 2007/03/29
 (85) Entrée phase nationale/National Entry: 2008/03/20
 (86) N° demande PCT/PCT Application No.: US 2006/036924
 (87) N° publication PCT/PCT Publication No.: 2007/035899
 (30) Priorité/Priority: 2005/09/21 (US11/231,462)

(51) Cl.Int./Int.Cl. *B63C 11/14* (2006.01)
 (71) Demandeur/Applicant:
 KIRBY MORGAN DIVE SYSTEMS, INC., US
 (72) Inventeurs/Inventors:
 MORGAN, WILLIAM B., US;
 MORGAN, CONNIE L., US;
 SCHULTZ, TRENT M., US
 (74) Agent: HILL & SCHUMACHER

(54) Titre : DEFLECTEUR DE BULLES POUR EQUIPEMENT DE PLONGEE
 (54) Title: BUBBLE DIVERTER FOR USE WITH DIVING EQUIPMENT



(57) Abrégé/Abstract:

A diving helmet (10) bubble diverter comprises a front skirt portion (24) and a rear skirt portion (25) attached to the front skirt portion (24) at one end. The rear skirt portion (25) is configured for mounting onto the diving helmet breathing regulator assembly

(57) **Abrégé(suite)/Abstract(continued):**

(12). The attached front and rear skirt portions (24, 25) form side pockets (46, 48) that divert exhaust air bubbles (40) away from the diver's mask when the rear skirt portion (25) is mounted onto the regulator assembly (12). The mounted rear skirt portion (25) forms a protective barrier between the exterior wall of the diving helmet (10) and the exhaust whisker (20) of the breathing regulator assembly (12) that prevents air bubbles (40) exiting the whisker (20) from coming into contact with the diving helmet (10) during diving activities.

(12) INTERNATIONAL APPLICATION PUBLISHED UNDER THE PATENT COOPERATION TREATY (PCT)

(19) World Intellectual Property Organization
International Bureau(43) International Publication Date
29 March 2007 (29.03.2007)

PCT

(10) International Publication Number
WO 2007/035899 A3(51) International Patent Classification:
B63C 11/14 (2006.01)(21) International Application Number:
PCT/US2006/036924(22) International Filing Date:
21 September 2006 (21.09.2006)

(25) Filing Language: English

(26) Publication Language: English

(30) Priority Data:
11/231,462 21 September 2005 (21.09.2005) US(71) Applicant (for all designated States except US): **KIRBY MORGAN DIVE SYSTEMS, INC.** [US/US]; 425 Garden Street, Santa Barbara, CA 93101 (US).

(72) Inventors; and

(75) Inventors/Applicants (for US only): **MORGAN, William, B.** [US/US]; 425 Garden Street, Santa Barbara, CA 93101 (US). **MORGAN, Connie, L.** [US/US]; 425 Garden Street, Santa Barbara, CA 93101 (US). **SCHULTZ, Trent, M.** [US/US]; 425 Garden Street, Santa Barbara, CA 93101 (US).(74) Agents: **CISLO, Daniel, M.** et al.; CISLO & THOMAS, LLP, 233 Wilshire Boulevard, Suite 900, Santa Monica, CA 90401 (US).

(81) Designated States (unless otherwise indicated, for every kind of national protection available): AE, AG, AL, AM,

AT, AU, AZ, BA, BB, BG, BR, BW, BY, BZ, CA, CH, CN, CO, CR, CU, CZ, DE, DK, DM, DZ, EC, EE, EG, ES, FI, GB, GD, GE, GH, GM, HN, HR, HU, ID, IL, IN, IS, JP, KE, KG, KM, KN, KP, KR, KZ, LA, LC, LK, LR, LS, LT, LU, LV, LY, MA, MD, MG, MK, MN, MW, MX, MY, MZ, NA, NG, NI, NO, NZ, OM, PG, PH, PL, PT, RO, RS, RU, SC, SD, SE, SG, SK, SL, SM, SV, SY, TJ, TM, TN, TR, TT, TZ, UA, UG, US, UZ, VC, VN, ZA, ZM, ZW.

(84) Designated States (unless otherwise indicated, for every kind of regional protection available): ARIPO (BW, GH, GM, KE, LS, MW, MZ, NA, SD, SL, SZ, TZ, UG, ZM, ZW), Eurasian (AM, AZ, BY, KG, KZ, MD, RU, TJ, TM), European (AT, BE, BG, CH, CY, CZ, DE, DK, EE, ES, FI, FR, GB, GR, HU, IE, IS, IT, LT, LU, LV, MC, NL, PL, PT, RO, SE, SI, SK, TR), OAPI (BF, BJ, CF, CG, CI, CM, GA, GN, GQ, GW, ML, MR, NE, SN, TD, TG).

Declaration under Rule 4.17:

— as to applicant's entitlement to apply for and be granted a patent (Rule 4.17(ii))

Published:— with international search report
— before the expiration of the time limit for amending the claims and to be republished in the event of receipt of amendments

(88) Date of publication of the international search report:

21 June 2007

For two-letter codes and other abbreviations, refer to the "Guidance Notes on Codes and Abbreviations" appearing at the beginning of each regular issue of the PCT Gazette.

(54) Title: BUBBLE DIVERTER FOR USE WITH DIVING EQUIPMENT

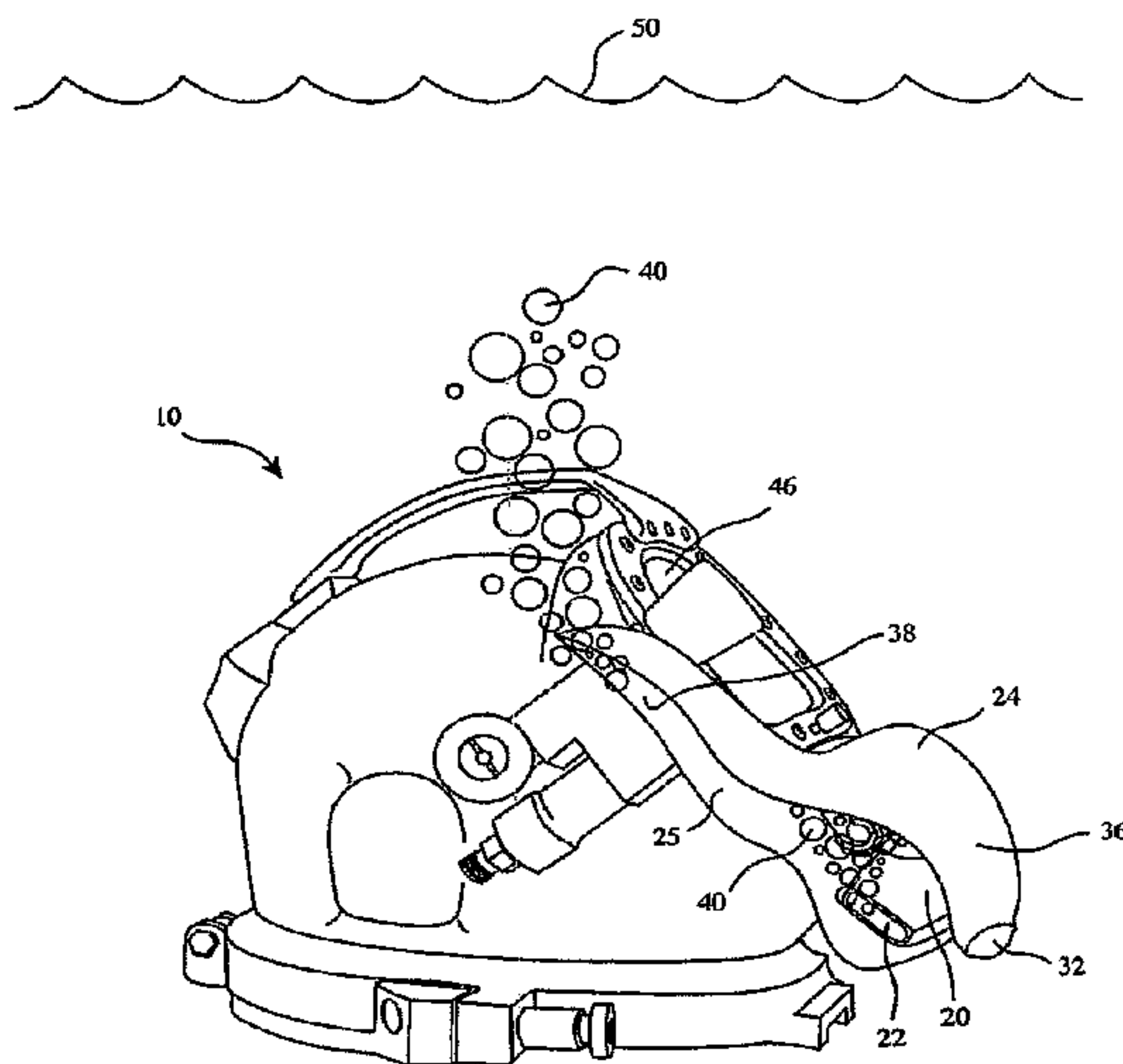

(57) Abstract: A diving helmet (10) bubble diverter comprises a front skirt portion (24) and a rear skirt portion (25) attached to the front skirt portion (24) at one end. The rear skirt portion (25) is configured for mounting onto the diving helmet breathing regulator assembly (12). The attached front and rear skirt portions (24, 25) form side pockets (46, 48) that divert exhaust air bubbles (40) away from the diver's mask when the rear skirt portion (25) is mounted onto the regulator assembly (12). The mounted rear skirt portion (25) forms a protective barrier between the exterior wall of the diving helmet (10) and the exhaust whisker (20) of the breathing regulator assembly (12) that prevents air bubbles (40) exiting the whisker (20) from coming into contact with the diving helmet (10) during diving activities.

WO 2007/035899 A3

BUBBLE DIVERTER FOR USE WITH DIVING EQUIPMENT

TECHNICAL FIELD

The present invention relates generally to diving equipment, and more
5 particularly to a bubble diverter for use with diving equipment.

BACKGROUND ART

Diving equipment typically includes a diving mask generally covering the eyes
and nose of the user and a breathing regulator assembly. The breathing regulator
assembly includes a mouthpiece that is connected via a hose to a carry-on air tank.
10 Diving equipment comes in a variety of configurations including FFMs (Full Face
Masks), diving helmets, SCUBA (Self Contained Underwater Breathing Apparatus)
and/or the like.

One problem currently existing with conventional diving equipment is that
underwater breathing creates exhaust air bubbles and attendant noise that may interfere
15 with the diver's vision and ability to communicate. Most air bubbles are exhausted as
the diver exhales through a rubber one-way valve that is mounted in the breathing
regulator. The exhaust air bubbles tend to travel upward in front of and around the
diver's face and head, ending up in front of the eyes and/or traveling past the diver's
cheeks, ears and temple area either directly or on the outside of a FFM mask frame or
20 helmet shell obstructing the diver's vision and communication abilities including the
diver's auditory ability.

This is especially true when a diver is positioned underwater with the top of his/her head towards the water surface, and looking forward or up, as the air bubbles generally ascend upward along the diver's face, mask frame or helmet shell. Consequently, divers have come to accept exhaust air bubbles as part of the diving
5 experience. To avoid air bubble interference some divers may try to position themselves with their heads facing downward or tilted to one side, or they may hold their breath when trying to hear during diving communications. Apart from being an inconvenience, this positioning may not always be possible especially when divers ascend and have to look up to ensure that they do not collide with object(s) above them.

10 Accordingly, there is a need for a convenient, portable, and detachable lighting system for a real estate sign that provides its own source of lighting, is lightweight, and is easy to install and remove from the sign.

DISCLOSURE OF INVENTION

Exemplary embodiments disclosed herein are generally directed to a bubble
15 diverter for use with diving equipment. The diving equipment includes in part a breathing regulator assembly and a diver's mask.

In accordance with one aspect of the invention, the bubble diverter comprises a front skirt portion and a rear skirt portion. The rear skirt portion is attached to the front skirt portion at one end and adapted for mounting onto the breathing regulator
20 assembly. The attached front and rear skirt portions form at least one side pocket adapted to divert exhaust air bubbles away from the diver's mask during diving activities when the rear skirt portion is mounted onto the breathing regulator assembly.

The mounted rear skirt portion forms a protective barrier adapted to prevent air bubbles exiting the breathing regulator assembly from coming into contact with the diving equipment.

This and other aspects of the invention will become apparent from a review of
5 the accompanying drawings and the following detailed description of the invention.

BRIEF DESCRIPTION OF DRAWINGS

The present invention is generally shown by way of reference to the accompanying drawings in which:

Figure 1 is a side perspective view of a conventional diving helmet;

10 Figure 2 is a front perspective view of the diving helmet of Fig. 1;

Figure 3 is a top plan view of a front skirt portion of a diving helmet bubble deflector pattern in accordance with an exemplary embodiment of the present invention;

Figure 4 is a top plan view of a rear skirt portion of a diving helmet bubble deflector pattern in accordance with another exemplary embodiment of the present
15 invention;

Figure 5 is a side perspective view of a conventional diving helmet being equipped with a bubble deflector constructed in accordance with the present invention;
and

Figure 6 is a front perspective view of the diving helmet and bubble deflector
20 combination of Fig. 5 in accordance with the present invention.

MODE(S) FOR CARRYING OUT THE INVENTION

The detailed description set forth below in connection with the appended drawings is intended as a description of exemplary embodiments and is not intended to represent the only forms in which the exemplary embodiments may be constructed and/or utilized. The description sets forth the functions and the sequence of steps for constructing and operating the exemplary embodiments in connection with the illustrated embodiments. However, it is to be understood that the same or equivalent functions and sequences may be accomplished by different embodiments that are also intended to be encompassed within the spirit and scope of the present invention.

Some embodiments of the present invention will be described in detail with reference to a diving helmet bubble deflector, as generally shown in Figures 3 - 6. Additional embodiments, features and/or advantages of the invention will become apparent from the ensuing description or may be learned by practicing the invention. In the figures, the drawings are not to scale with like numerals referring to like features throughout both the drawings and the description.

Figure 1 is a side perspective view of a conventional diving helmet **10** provided with a breathing regulator assembly **12** operatively coupled between a breathing regulator mount tube **14** and an air supply tube **16** (Figs. 1 - 2). Breathing regulator assembly **12** includes in part an air release or purge button **18** (Figs. 1 - 2), a breathing regulator adjustment knob **19** (Fig. 2) and an exhaust whisker **20** (Figs. 1 - 2). Whisker **20** lets exhaust air out as bubbles via outlet **22** (Fig. 1). The exhaust air bubbles tend to travel upwards, i.e. toward water surface **50** (Figs. 5 - 6), generally blocking the diver's vision. If the diver is looking slightly downward the exhaust air bubbles tend to

travel along the sides of diving helmet **10** generating audible noise inside diving helmet **10** which distracts the diver during communication with other divers and/or support crew above water.

Figure 3 is a top plan view of a generally bird-like front skirt portion **24** of a diving helmet bubble deflector pattern **26** in accordance with an exemplary embodiment of the present invention. Front skirt portion **24** is provided at one end with a pair of apertures **28, 30** adapted for mounting weight(s) which keep the bottom portion of the skirt from rising up due to buoyancy and/or exhaust bubble flow and blocking the diver's view during diving activities such as when the diver is in a face forward or face up position. In this regard, Fig. 6 generally shows a front weight **32** mounted in accordance with the present invention to decrease buoyancy and maintain proper positioning of the skirt during diving activities.

Front skirt portion **24** may be constructed from flexible materials such as rubber, neoprene, silicone, urethane, cloth and/or the like. Front skirt portion **24** may also be constructed from a combination of rigid and flexible materials, as needed. In one embodiment, front skirt portion **24** may be made of relatively thin and transparent flexible material. Front skirt portion **24** includes a generally curvilinear top edge **34** (Fig. 3).

Figure 4 is a top plan view of a generally bird-like rear skirt portion **25** of a diving helmet bubble deflector pattern **26** in accordance with another exemplary embodiment of the present invention. Rear skirt portion **25** is provided with a breathing regulator mount tube aperture **29** and an air supply tube aperture **31**, as generally

depicted in Fig. 4. Rear skirt portion **25** may be constructed from flexible materials such as rubber, neoprene, silicone, cloth and/or the like. Rear skirt portion **25** may be also constructed from a combination of rigid and flexible materials, as needed. In one embodiment, rear skirt portion **25** may be made of relatively thin and transparent flexible material. Rear skirt portion **25** has a top edge **35** (Fig. 4) that generally follows the contours of top edge **34** of front skirt portion **24** (Fig. 3).

Construction of a diving helmet bubble deflector in accordance with the present invention includes attaching top edge **35** (Fig. 4) of rear skirt portion **25** to top edge **34** (Fig. 3) of front skirt portion **24** and mounting weight **32** (Fig. 6) to front skirt portion **24**. Attachment of top edges **34**, **35** may include gluing, sewing, molding and/or the like. Top edges **34**, **35** may also be removably attached via Velcro® strips and the like. Attached top edges **34**, **35** form generally a crease **33** along which front skirt portion **24** is folded over rear skirt portion **25**.

A bubble deflector **36** constructed in accordance with the present invention and mounted under the viewing lens **38** of diving helmet **10** is generally depicted in reference to Figs. 5 - 6. Bubble deflector **36** may be mounted to diving helmet **10** by uncoupling breathing regulator mount tube **14** and air supply tube **16** (Figs. 1 - 2) from breathing regulator assembly **12** (Fig. 1), inserting the uncoupled breathing regulator mount tube **14** and air supply tube **16** (Figs. 1 - 2) into breathing regulator mount tube aperture **29** and air supply tube aperture **31** of rear skirt portion **25** (Fig. 4), respectively, and re-coupling breathing regulator mount tube **14** and air supply tube **16** (Figs. 1 - 2) to breathing regulator assembly **12**.

The mounted bubble deflector (36) partially encloses exhaust whisker 20 (Figs. 1 - 2) capturing air bubbles 40 exiting whisker 20 (Fig. 5). Specifically, the inserted rear skirt portion (25) forms a protective barrier between the exterior wall of diving helmet 10 and outlet 22 of exhaust whisker 20 which prevents air bubbles 40 exiting whisker 20 from coming into contact with diving helmet 10, as generally illustrated in Figs. 5 - 6. The bubble noise commonly experienced by divers using known diving apparatuses is thus eliminated. Moreover, terminal ends 42, 43, 44 and 45 (Figs. 3 - 4) of attached front and rear skirt portions 24, 25 form side pockets 46 and 48, respectively, which divert exiting air bubbles 40 outward away from diver's viewing lens 38 and helmet 10 toward water surface 50, as generally shown in reference to Figs. 5 - 6. The diverted air bubbles (40) advantageously do not obstruct the diver's vision during various diving activities. Mounted bubble deflector 36 also advantageously provides easy access for the diver to purge button 18 (Figs. 1 - 2) through flexible front skirt portion 24 as well as to breathing regulator adjustment knob 19 (Fig. 2) which may be conveniently reached under front skirt portion 24, as generally depicted in Fig. 6.

A person skilled in the art would readily appreciate that the bubble deflector of the present invention may be adapted for use with a full face mask (FFM), SCUBA (Self Contained Underwater Breathing Apparatus) diving equipment and/or the like. The bubble deflector of the present invention may be assembled in other ways and/or with other suitable components and/or materials, as long as there is no departure from the intended purpose and scope of the present invention. The exemplary embodiments

described hereinabove are merely illustrative of the general principles of the present invention. Various design modifications may be employed that would reside within the scope of the invention. Thus, by way of example, but not of limitation, alternative configurations may be utilized in accordance with the teachings herein. Accordingly,
5 the drawings and description are illustrative and not meant to be a limitation thereof.

Moreover, all terms should be interpreted in the broadest possible manner consistent with the context. In particular, the terms "comprises" and "comprising" should be interpreted as referring to elements, components, or steps in a non-exclusive manner, indicating that the referenced elements, components, or steps may be present,
10 or utilized, or combined with other elements, components, or steps that are not expressly referenced. Thus, it is intended that the invention cover all embodiments and variations thereof as long as such embodiments and variations come within the scope of the appended claims and their equivalents.

INDUSTRIAL APPLICABILITY

15 The bubble diverter of the present invention has a wide range of industrial applicability. Particularly, when configured and used in accordance with the general principles of the present invention, the bubble diverter is adapted for use with a full face mask (FFM), SCUBA (Self Contained Underwater Breathing Apparatus) diving equipment and/or the like. The bubble deflector of the present invention may be
20 assembled in other ways and/or with other suitable components and/or materials, as needed.

CLAIMS**WHAT IS CLAIMED IS:**

1. A bubble diverter for use with diving equipment including a breathing
2 regulator assembly and a diver's mask having a viewing lens, said
bubble diverter comprising:
4 a front skirt portion; and
a rear skirt portion attached to said front skirt portion at one end and
6 adapted for mounting onto the breathing regulator assembly,
said attached front and rear skirt portions forming at least one side
8 pocket adapted to divert exhaust air bubbles away from the diver's viewing lens
during diving activities when said rear skirt portion is mounted onto the
10 breathing regulator assembly,
said mounted rear skirt portion forming a protective barrier adapted to
12 prevent air bubbles exiting the breathing regulator assembly from coming into
contact with the diving equipment.
2. The bubble diverter of Claim 1, wherein said front skirt portion includes
2 a substantially curvilinear top edge.
3. The bubble diverter of Claim 2, wherein said rear skirt portion includes
2 a top edge that substantially follows the contours of said top edge of said
front skirt portion.

4. The bubble diverter of Claim 3, wherein said top edges of said front and rear skirt portions are attached to form a crease along which said front skirt portion is folded over said rear skirt portion.
5. The bubble diverter of Claim 4, wherein said top edges of said front and rear skirt portions are attached via glue.
6. The bubble diverter of Claim 4, wherein said top edges of said front and rear skirt portions are sewn together.
7. The bubble diverter of Claim 4, wherein said top edges of said front and rear skirt portions are molded together.
8. The bubble diverter of Claim 4, wherein said top edges of said front and rear skirt portions are removably attached via Velcro® strips.
9. The bubble diverter of Claim 2, wherein said front skirt portion further includes at least one aperture adapted for mounting at least one weight to decrease buoyancy.

- 2 10. The bubble diverter of Claim 3, wherein said rear skirt portion further includes at least one aperture configured for breathing regulator assembly mounting.
- 2 11. The bubble diverter of Claim 1, wherein each of said front and rear skirt portions has a substantially bird-like configuration.
- 2 12. The bubble diverter of Claim 1, wherein each of said front and rear skirt portions is made of flexible material.
- 2 13. The bubble diverter of Claim 1, wherein said front and rear skirt portions are made of flexible and rigid materials.
- 2 14. The bubble diverter of Claim 12, wherein said flexible material is selected from the group consisting of rubber, neoprene, silicone, urethane, cloth and a combination thereof.
- 2 15. The bubble diverter of Claim 1, wherein said protective barrier eliminates bubble noise during diving activities.

- 2 16. The bubble diverter of Claim 1, wherein diverting exhaust air bubbles via said at least one side pocket prevents diver's vision from being obstructed during diving activities.
- 2 17. The bubble diverter of Claim 1, wherein said attached and mounted rear and front skirt portions are configured to provide access to the breathing regulator assembly during diving activities.
- 2 18. The bubble diverter of Claim 1, wherein said front and rear skirt portions are configured for use with a diving helmet.
- 2 19. The bubble diverter of Claim 1, wherein said front and rear skirt portions are configured for use with a full face mask (FFM) diving equipment.
- 2 20. The bubble diverter of Claim 1, wherein said front and rear skirt portions are configured for use with SCUBA (Self Contained Underwater Breathing Apparatus) diving equipment.
- 2 21. The bubble diverter of Claim 1, wherein said front skirt portion is made of substantially thin and transparent flexible material.

22. The bubble diverter of Claim 1, wherein said rear skirt portion is made of substantially thin and transparent flexible material.

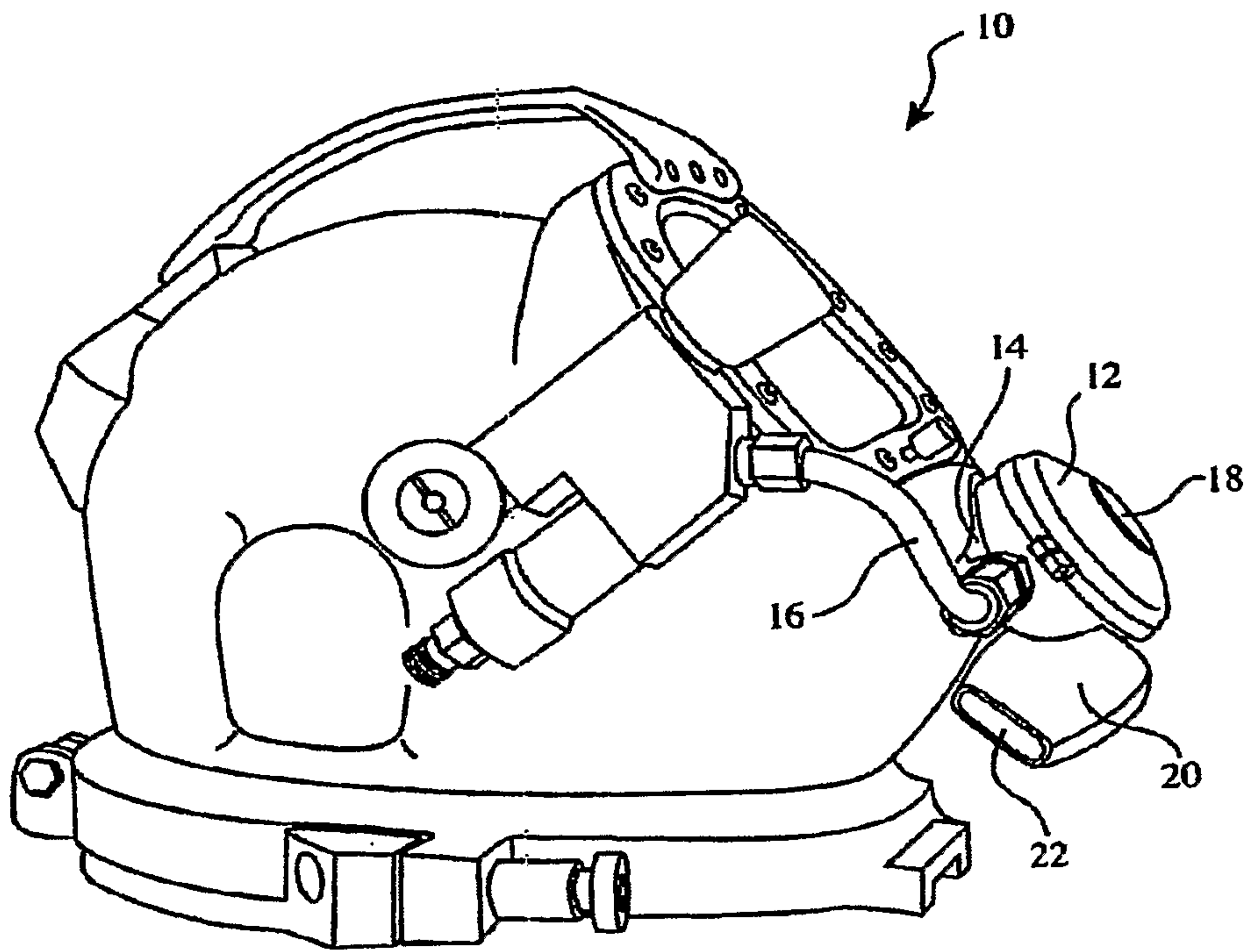

Figure 1

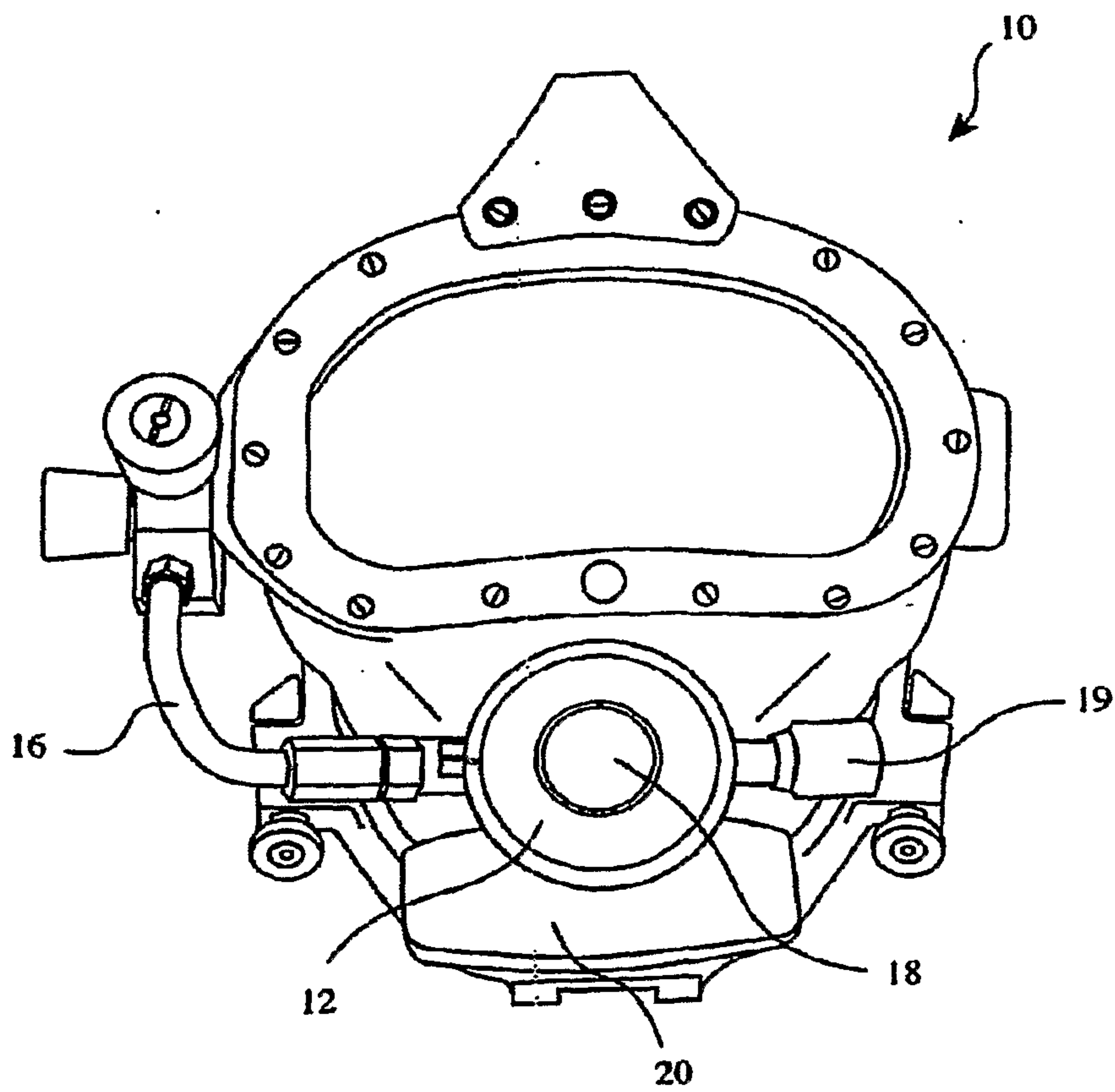

Figure 2

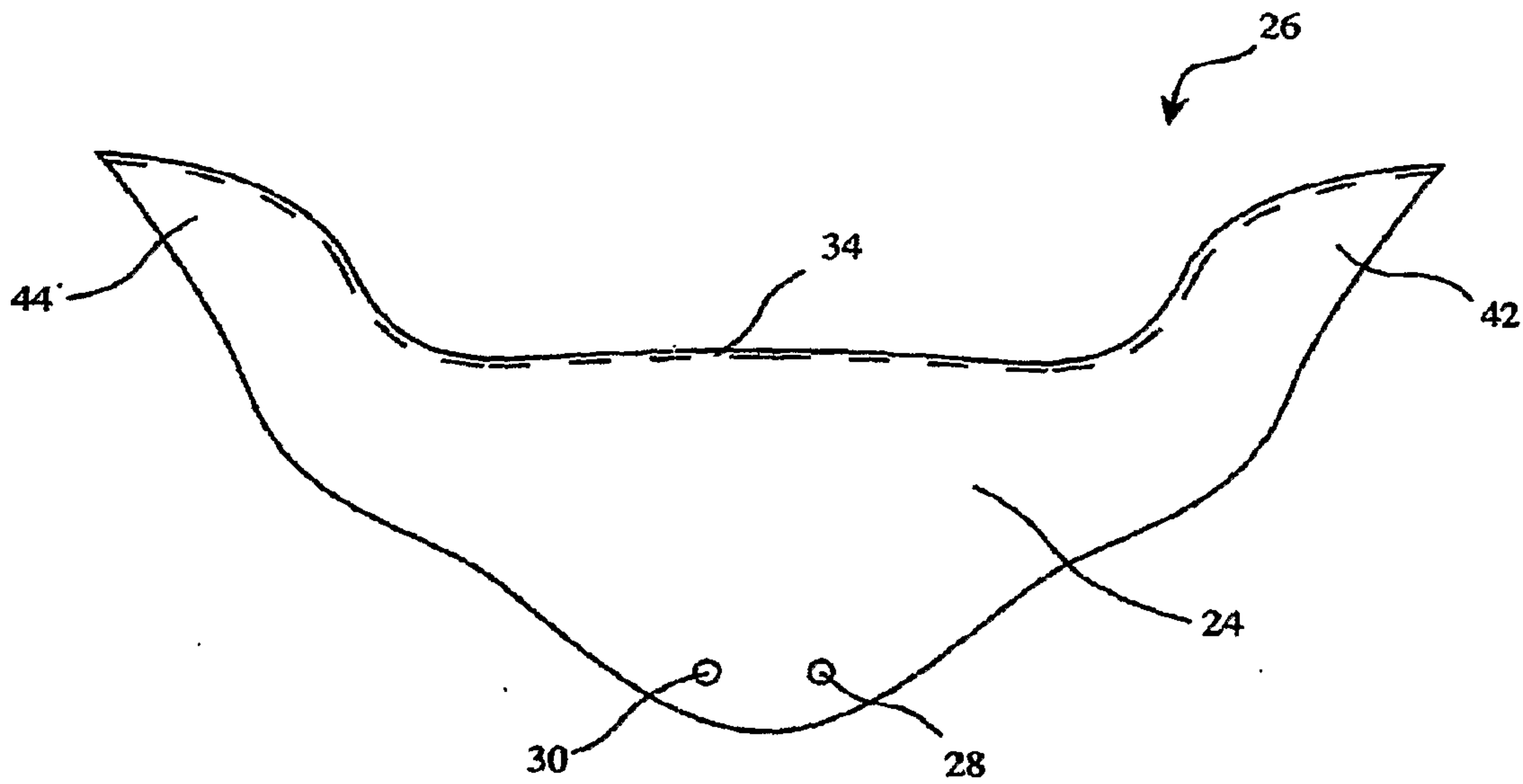

Figure 3

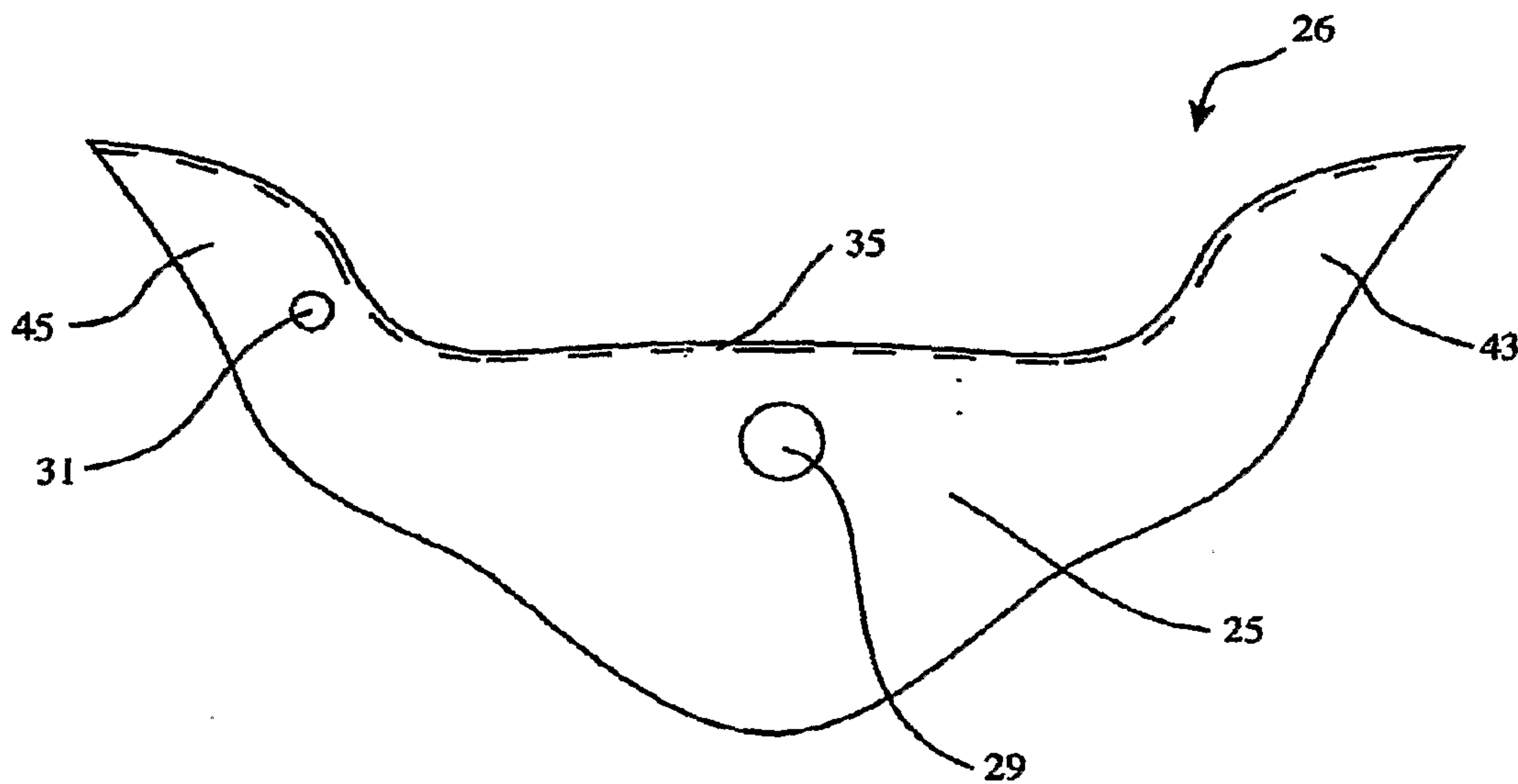

Figure 4

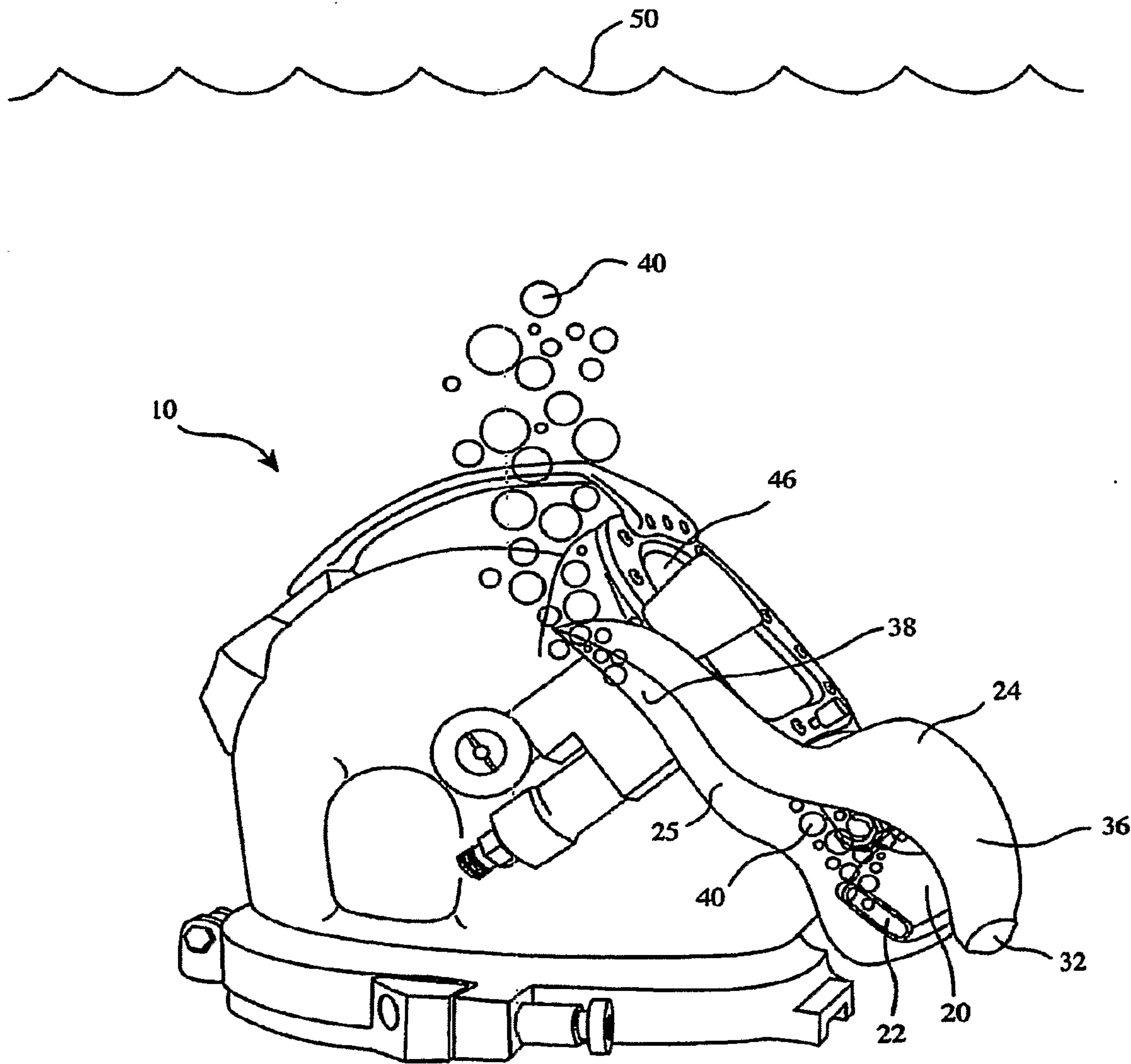

Figure 5

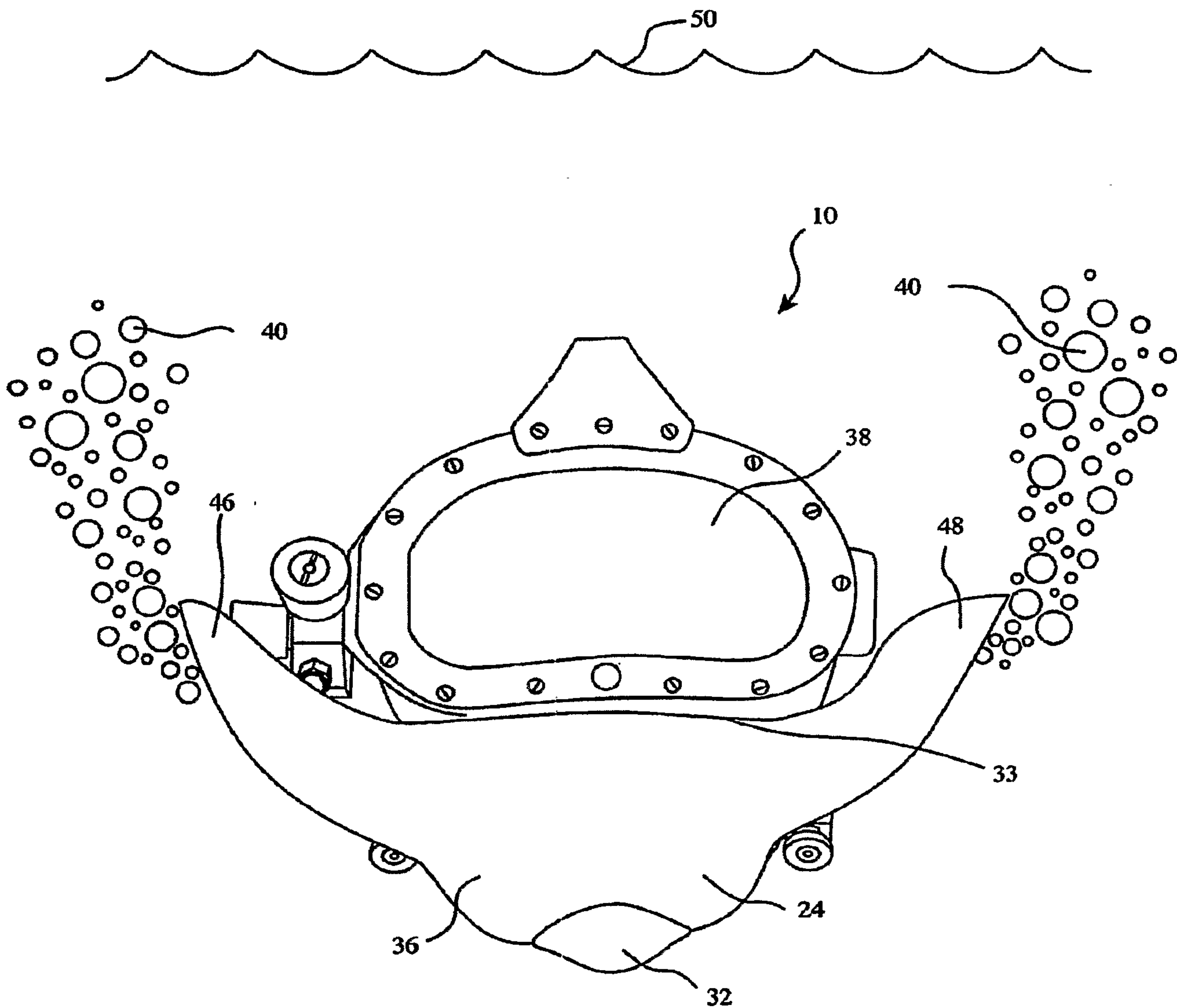

Figure 6

