



- (51) International Patent Classification:  
F26B 17/00 (2006.01) F26B 17/20 (2006.01)  
F26B 17/18 (2006.01)
- (21) International Application Number:  
PCT/US2016/051185
- (22) International Filing Date:  
10 September 2016 (10.09.2016)
- (25) Filing Language: English
- (26) Publication Language: English
- (30) Priority Data:  
15/048,513 19 February 2016 (19.02.2016) US
- (72) Inventor; and
- (71) Applicant : MARDIKIAN, Albert [US/US]; 45 Gleta Point Drive, Corona Del Mar, CA 92625 (US).
- (74) Agent: GANJIAN, Peter; Patent Law Agency, LLC, 2029 Verdugo Blvd., #1031, Montrose, CA 91020-1626 (US).
- (81) Designated States (unless otherwise indicated, for every kind of national protection available): AE, AG, AL, AM, AO, AT, AU, AZ, BA, BB, BG, BH, BN, BR, BW, BY,

BZ, CA, CH, CL, CN, CO, CR, CU, CZ, DE, DK, DM, DO, DZ, EC, EE, EG, ES, FI, GB, GD, GE, GH, GM, GT, HN, HR, HU, ID, IL, IN, IR, IS, JP, KE, KG, KN, KP, KR, KW, KZ, LA, LC, LK, LR, LS, LU, LY, MA, MD, ME, MG, MK, MN, MW, MX, MY, MZ, NA, NG, NI, NO, NZ, OM, PA, PE, PG, PH, PL, PT, QA, RO, RS, RU, RW, SA, SC, SD, SE, SG, SK, SL, SM, ST, SV, SY, TH, TJ, TM, TN, TR, TT, TZ, UA, UG, US, UZ, VC, VN, ZA, ZM, ZW.

- (84) Designated States (unless otherwise indicated, for every kind of regional protection available): ARIPO (BW, GH, GM, KE, LR, LS, MW, MZ, NA, RW, SD, SL, ST, SZ, TZ, UG, ZM, ZW), Eurasian (AM, AZ, BY, KG, KZ, RU, TJ, TM), European (AL, AT, BE, BG, CH, CY, CZ, DE, DK, EE, ES, FI, FR, GB, GR, HR, HU, IE, IS, IT, LT, LU, LV, MC, MK, MT, NL, NO, PL, PT, RO, RS, SE, SI, SK, SM, TR), OAPI (BF, BJ, CF, CG, CI, CM, GA, GN, GQ, GW, KM, ML, MR, NE, SN, TD, TG).

Published: with international search report (Art. 21(3))

(54) Title: APPARATUS FOR PRESSING AND DEHYDRATING OF WASTE

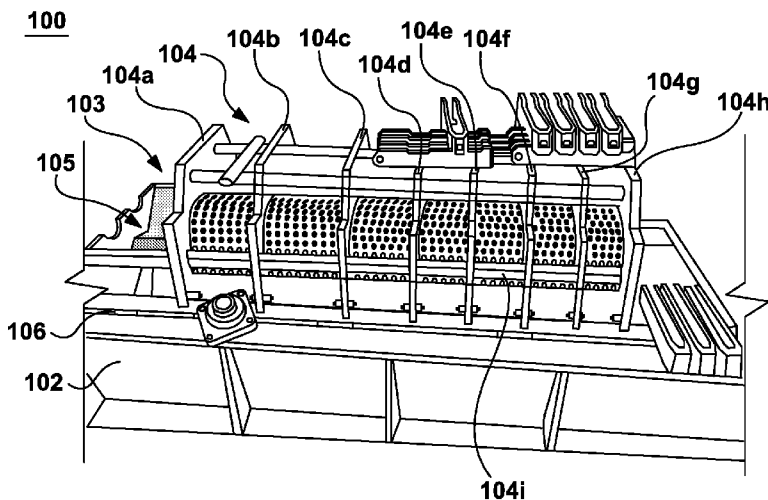

FIG. 1A

(57) Abstract: Apparatus for pressing and drying a pre-defined amount of waste includes a metal main frame positioned to provide rigid support, and a body mechanically linked to the main frame through a plurality of linkage plates. The apparatus also includes an inlet vertically mounted on the body and a twin screw assembly to press and dehydrate the pre-defined amount of waste. A plurality of mesh screens is rigidly linked to the main frame along the longitudinal axis of the apparatus to remove compressed liquid. The body is also designed to support rotation of the twin screw assembly, and the inlet includes an ingress cross-sectional opening to receive the pre-defined amount of waste.



## APPARATUS FOR PRESSING AND DEHYDRATING OF WASTE

### BACKGROUND

The present disclosure relates to a field of waste management. More specifically, the present disclosure relates to an apparatus to press and dehydrate waste.

5 In the recent years, the amount of waste has increased sharply. This increase can be attributed to factors such as increased demand and production of livestock and agricultural produce, mismanagement of livestock and agricultural produce, lack of proper waste management resources and the like. The waste primarily includes municipal waste, green waste, organic waste and the like. This waste occupies large sections of land. This waste does not  
10 decompose properly and affects the soil quality, air quality and water resource present in the vicinity. In addition, this waste is wet, has a bad odor and contains harmful bacteria. In addition, this occupancy of waste poses negative psychological impact on the neighborhood. To overcome this, the waste is pressed and dehydrated. In conventional treatment methods, the waste obtained from municipal dump areas is commonly transferred to multiple chambers  
15 equipped with helical ridges housed in large mechanical structures.

In the prior art, an apparatus is provided for dehydrating the pre-defined amount of waste using a screw press with a shear panel formed separately to remove liquid content. The apparatus using a screw press with a shear panel which is separately formed comprises a central shaft, a screw, a plurality of shear panels, and a shear blade. The screw is formed in a spiral  
20 shape on the outer circumference of the central shaft and dehydrates sludge by generating a compressive force as the sludge is transferred when the central shaft rotates. The shear panel is separated to the central shaft to be aligned to the outside of the screw and is fixed to the screw. The shear blade removes sludge solid bodies blocking a drum mesh or a perforated hole as the central shaft in which the screw is attached rotates.

Other prior art includes an apparatus is provided for mechanically dewatering municipal sewage sludge or peat. The under watered feed material is passed into the first end of a cylindrical porous wall and pressurized within the cylindrical wall by a rotating screw conveyor, which also transports the solids toward the second end of the cylindrical wall. The screw conveyor comprises a central shaft which has at least two built-up sections of gradually increasing diameter providing a compression ratio of 2.5:1.0. The flight depth of the screw conveyor increases by a factor greater than 2.0 after each built-up section. The distance between the edge of the screw conveyor blade and the inner surface of the cylindrical wall and the structure of the openings in the wall have specific dimensional limitations. Fibrous additives may be used to aid in dewatering peat and secondary sludge.

Other prior art includes an apparatus is provided for de-watering waste. A main shaft is rotated about a longitudinal axis at a first rate. A screw shaft coupled to the main shaft is rotated about the longitudinal axis at the first rate. A screw shaft coupled to the main shaft is rotated about the longitudinal axis at the first rate. Screw flighting coupled to the screw shaft is rotated about the longitudinal axis at the first rate. A first and second stage drum is rotated about the longitudinal axis at a second rate. Waste is introduced to a first area defined by an outer surface of the screw shaft and an inner surface of the first stage drum. Moisture is removed from the waste through a first slot coupled to the first stage drum. The waste is transported with the screw flighting from the first area to a second area defined by an outer surface of the screw shaft and an inner surface of the second stage drum, the second area being larger than the first area. Moisture is removed from the waste through a second slot coupled to the second stage drum.

Other prior art includes an apparatus is provided for separating waste liquid and solid material. The apparatus includes an upwardly inclined passage containing an auger for conveying the solid waste material upwardly along the passage, with an inlet opening at a lower end of the passage for receiving a mixture of waste liquid and solid material into the auger. In

addition, the apparatus includes a drainage opening at the lower end of the cylindrical passage for draining liquid from the solid waste conveyed by the auger. In addition, the apparatus includes a compactor for receiving the solid material fed upwardly by the auger and compacting the solid waste material. An extruder receives and extrudes the compacted solid waste material from the compactor, and may be arranged to convert the compacted material into pellets.

The prior art has several disadvantages. The apparatus mentioned in these prior arts have lower efficiency levels. Further, these apparatus have high fuel consumption and increased energy costs associated with inefficient operation. In addition, these apparatus fail to accommodate materials with non-uniform initial moisture content. In addition, these apparatus requires large size of chambers for accommodating organic waste. This consequent space requirements poses difficulty in transporting, assembling and placing the apparatus in operation, particularly in remote locations. These apparatus are generally complex, require much manpower and are operationally uneconomical.

### SUMMARY

In an aspect, the present disclosure provides an apparatus for pressing and dehydrating a pre-defined amount of waste. The apparatus includes a main frame positioned for providing a rigid support to the apparatus. Further, the apparatus includes a body mechanically linked to the main frame through a plurality of linkage plates. Furthermore, the apparatus includes an inlet vertically mounted on the body. Further, the apparatus includes a twin screw assembly mounted on the main frame and horizontally positioned for rotation along a longitudinal axis of the apparatus. Further, the apparatus includes a plurality of mesh screens rigidly linked to the main frame along the longitudinal axis of the apparatus. Moreover, the main frame is a metallic main frame. In addition, the body is designed to support rotation of the twin screw assembly. Further, the inlet has an ingress cross-sectional opening to receive the pre-defined amount of waste. In addition, the inlet has an egress cross-sectional opening to transfer the pre-defined

amount of waste to the twin screw assembly. Further, the body includes a plurality of vertical rigid supports mounted perpendicular to the longitudinal axis of the apparatus. The plurality of vertical rigid supports is mounted vertically to the main frame. In addition, the plurality of vertical rigid supports provides vertical support to the apparatus. Moreover, the body includes one or more horizontal rigid supports mounted horizontally along the longitudinal axis of the apparatus. Furthermore, the twin screw assembly is configured to press and dehydrate the pre-defined amount of waste. Further, each mesh screen of the plurality of mesh screens includes a plurality of fishers for removing compressed liquid. In addition, the plurality of mesh screens encapsulates the twin screw assembly.

In an embodiment of the present disclosure, the main frame includes a first section for holding a driving unit and a second section for holding the body.

In an embodiment of the present disclosure, the twin screw assembly includes a first screw and a second screw positioned along the longitudinal axis of the apparatus. The first screw and the second screw are mechanically coupled to a driving shaft of the driving unit through a chain and sprocket assembly. Moreover, the first screw and the second screw include a first end and a second end. In addition, the first end is a near end and the second end is a far end. In addition, the twin screw assembly includes a plurality of helical ridges rigidly mounted on the first screw and the second screw. In addition, each helical ridge of the plurality of helical ridges has a pre-defined progressive pitch varying from the first end to the second end.

In an embodiment of the present disclosure, the pre-defined progressive pitch is  $120^\circ$  at the first end. In addition, the pre-defined progressive pitch is  $95^\circ$  at the second end.

In an embodiment of the present disclosure, the driving unit is positioned adjacent to the body. In addition, the driving unit is mounted on the first section of the main frame.

Moreover, the driving unit is coupled to the chain and sprocket assembly.

In an embodiment of the present disclosure, the driving unit is an electric motor assembly.

In another embodiment of the present disclosure, the driving unit is an engine assembly.

In an embodiment of the present disclosure, the plurality of mesh screens includes a  
5 primary mesh screen and a secondary mesh screen. The secondary mesh screen surrounds the  
primary mesh screen circumferentially. Moreover, the plurality of mesh screens is a stainless  
steel mesh screen.

In an embodiment of the present disclosure, the primary mesh screen includes a first  
plurality of fishers of the plurality of fishers. The first plurality of fishers has a first pre-  
10 defined nominal diameter range. In addition, the first pre-defined nominal diameter range is  
2mm-4mm.

In an embodiment of the present disclosure, the secondary mesh screen includes a  
second plurality of fishers of the plurality of fishers. The second plurality of fishers has a  
second pre-defined nominal diameter range. In addition, the second pre-defined nominal  
15 diameter range is 6mm-8mm.

In an embodiment of the present disclosure, the apparatus includes an outlet to expel a  
processed waste. Moreover, the outlet is positioned at the second end.

In another aspect, the present disclosure provides an apparatus for pressing and  
dehydrating a pre-defined amount of waste. The apparatus includes a main frame positioned  
20 for providing a rigid support to the apparatus. Further, the apparatus includes a body  
mechanically linked to the main frame through a plurality of linkage plates. Furthermore, the  
apparatus includes an inlet vertically mounted on the body. Further, the apparatus includes a  
twin screw assembly mounted on the main frame and horizontally positioned for rotation along  
a longitudinal axis of the apparatus. Further, the apparatus includes a plurality of mesh screens  
25 rigidly linked to the main frame along the longitudinal axis of the apparatus. Moreover, the

main frame is a metallic main frame. In addition, the body is designed to support rotation of a twin screw assembly. Further, the inlet has an ingress cross-sectional opening to receive the pre-defined amount of waste. In addition, the inlet has an egress cross-sectional opening to transfer the pre-defined amount of waste to the twin screw assembly. Further, the body

5 includes a plurality of vertical rigid supports mounted perpendicular to the longitudinal axis. The plurality of vertical rigid supports is mounted vertically to the main frame. In addition, the plurality of vertical rigid supports provides vertical support to the apparatus. Moreover, the body includes one or more horizontal rigid supports mounted horizontally along the longitudinal axis of the apparatus. Further, the twin screw assembly is configured to press and

10 dehydrate the pre-defined amount of waste. The twin screw assembly includes a first screw and a second screw positioned along the longitudinal axis of the apparatus. The first screw and the second screw are mechanically coupled to a driving shaft of a driving unit through a chain and sprocket assembly. Moreover, the first screw and the second screw include a first end and a second end. In addition, the first end is a near end and the second end is a far end.

15 Furthermore, the twin screw assembly includes a plurality of helical ridges rigidly mounted on the first screw and the second screw. In addition, each helical ridge of the plurality of helical ridges has a pre-defined progressive pitch varying from the first end to the second end. Further, each mesh screen of the plurality of mesh screens includes a plurality of fishers to remove compressed liquid from the pre-defined amount of waste. In addition, the plurality of

20 mesh screens encapsulates the twin screw assembly.

In an embodiment of the present disclosure, the pre-defined progressive pitch is  $120^\circ$  at the first end. In addition, the pre-defined progressive pitch is  $95^\circ$  at the second end.

In an embodiment of the present disclosure, the plurality of mesh screens includes a primary mesh screen and a secondary mesh screen. The secondary mesh screen surrounds the

primary mesh screen circumferentially. Moreover, the plurality of mesh screens is a stainless steel mesh screen

In an embodiment of the present disclosure, the primary mesh screen includes a first plurality of fishers of the plurality of fishers. The first plurality of fishers has a first pre-defined nominal diameter range. In addition, the first pre-defined nominal diameter range is 2mm-4mm.

In an embodiment of the present disclosure, the secondary mesh screen includes a second plurality of fishers of the plurality of fishers. The second plurality of fishers has a second pre-defined nominal diameter range. In addition, the second pre-defined nominal diameter range is 6mm-8mm.

In an embodiment of the present disclosure, the apparatus includes an outlet to expel a processed waste. Moreover, the outlet is positioned at the second end.

In yet another aspect, the present disclosure provides an apparatus for pressing and dehydrating a pre-defined amount of waste. The apparatus includes a main frame positioned for providing a rigid support to the apparatus. Further, the apparatus includes a body mechanically linked to the main frame through a plurality of linkage plates. Furthermore, the apparatus includes an inlet vertically mounted on the body. Further, the apparatus includes a twin screw assembly mounted on the main frame and horizontally positioned for rotation along a longitudinal axis of the apparatus. Further, the apparatus includes a plurality of mesh screens rigidly linked to the main frame along the longitudinal axis of the apparatus. Moreover, the main frame has a plurality of balance points. Also, the main frame is a metallic main frame. In addition, the main frame has a first section for holding a driving unit and a second section for holding the body. In addition, the body is designed to support rotation of the twin screw assembly. The body includes a plurality of vertical rigid supports mounted perpendicular to the longitudinal axis of the apparatus. The plurality of vertical rigid supports is mounted vertically



to the main frame. In addition, the plurality of vertical rigid supports provides vertical support to the apparatus. Moreover, the body includes one or more horizontal rigid supports mounted horizontally along the longitudinal axis of the apparatus. In addition, the body is designed to support rotation of the twin screw assembly. Further, the inlet has an ingress cross-sectional opening to receive the pre-defined amount of waste. In addition, the inlet has an egress cross-sectional opening to transfer the pre-defined amount of waste to the twin screw assembly. Further, the twin screw assembly is configured to press and dehydrate the pre-defined amount of waste. The twin screw assembly includes a first screw and a second screw positioned along the longitudinal axis of the apparatus. The first screw and the second screw are mechanically coupled to a driving shaft of the driving unit through a chain and sprocket assembly. Moreover, the first screw and the second screw include a first end and a second end. In addition, the first end is a near end and the second end is a far end. Furthermore, the twin screw assembly includes a plurality of helical ridges rigidly mounted on the first screw and the second screw. In addition, each helical ridge of the plurality of helical ridges has a pre-defined progressive pitch varying from the first end to the second end. Moreover, the pre-defined progressive pitch is  $120^\circ$  at the first end. In addition, the pre-defined progressive pitch is  $95^\circ$  at the second end. Further, each mesh screen of the plurality of mesh screens includes a plurality of fishers to remove compressed liquid from the pre-defined amount of waste. In addition, the plurality of mesh screens encapsulates the twin screw assembly. Moreover, the plurality of mesh screens includes a primary mesh screen and a secondary mesh screen. The secondary mesh screen surrounds the primary mesh screen circumferentially. In addition, the plurality of mesh screens is a stainless steel mesh screen.

In an embodiment of the present disclosure, the primary mesh screen includes a first plurality of fishers of the plurality of fishers. The first plurality of fishers has a first pre-defined nominal diameter range. In addition, the first pre-defined nominal diameter range is

2mm-4mm. Moreover, the secondary mesh screen includes a second plurality of fishers of the plurality of fishers. The second plurality of fishers has a second pre-defined nominal diameter range. In addition, the second pre-defined nominal diameter range is 6mm-8mm.

In an embodiment of the present disclosure, the apparatus includes an outlet to expel a processed waste. Moreover, the outlet is positioned at the second end.

### BRIEF DESCRIPTION OF THE DRAWINGS

Having thus described the invention in general terms, reference will now be made to the accompanying drawings, which are not necessarily drawn to scale, and wherein:

**FIG. 1A** illustrates an internal perspective view of an apparatus for pressing and dehydrating a pre-defined amount of waste, in accordance with various embodiments of the present disclosure;

**FIG. 1B** illustrates a side profile view of the apparatus of **FIG. 1A**, in accordance with an embodiment of the present disclosure;

**FIG. 1C** illustrates a rear profile view of the apparatus of **FIG. 1A**, in accordance with another embodiment of the present disclosure;

**FIG. 2A** illustrates a perspective view of a twin screw assembly of the apparatus of **FIG. 1A**, in accordance with an embodiment of the present disclosure;

**FIG. 2B** illustrates a part perspective view of the twin screw assembly of the apparatus of **FIG. 1A**, in accordance with another embodiment of the present disclosure;

**FIG. 3** illustrates the part perspective view of a plurality of mesh screens of the apparatus of **FIG. 1A**, in accordance with an embodiment of the present disclosure;

**FIG. 4** illustrates a side profile view of another apparatus, in accordance with an embodiment of the present disclosure;

**FIG. 5A** illustrates a schematic view of a tumbler assembly of the apparatus of **FIG. 4**, in accordance with an embodiment of the present disclosure.

**FIG. 5B** illustrates a cross-sectional view of a tumbler assembly of the apparatus of **FIG. 4**, in accordance with an embodiment of the present disclosure.

**FIG. 5C** illustrates the part perspective view of a tumbler assembly of the apparatus of **FIG. 4**, in accordance with an embodiment of the present disclosure.

5 **FIG. 5D** illustrates a side sectional view of the tumbler assembly of the apparatus of the **FIG. 4**, in accordance with an embodiment of the present disclosure.

It should be noted that the accompanying figures are intended to present illustrations of exemplary embodiments of the present disclosure. These figures are not intended to limit the scope of the present disclosure. It should also be noted that accompanying figures are not  
10 necessarily drawn to scale.

#### **DETAILED DESCRIPTION**

Reference will now be made in detail to selected embodiments of the present disclosure in conjunction with accompanying figures. The embodiments described herein are not intended to limit the scope of the disclosure, and the present disclosure should not be construed as limited  
15 to the embodiments described. This disclosure may be embodied in different forms without departing from the scope and spirit of the disclosure. It should be understood that the accompanying figures are intended and provided to illustrate embodiments of the disclosure described below and are not necessarily drawn to scale. In the drawings, like numbers refer to like elements throughout, and thicknesses and dimensions of some components may be  
20 exaggerated for providing better clarity and ease of understanding.

It should be noted that the terms "first", "second", and the like, herein do not denote any order, quantity, or importance, but rather are used to distinguish one element from another. Further, the terms "a" and "an" herein do not denote a limitation of quantity, but rather denote the presence of at least one of the referenced item.

**FIG. 1A** illustrates an internal perspective view of an apparatus **100** for pressing and dehydrating of a pre-defined amount of waste, in accordance with various embodiments of the present disclosure. The apparatus **100** is a mechanical device configured to press and dehydrate the pre-defined amount of the waste. The pre-defined amount of waste is obtained from a plurality of sources. The pre-defined amount of waste includes waste livestock, animal excreta, municipal solid waste, green waste, organic waste and the like. In general, the pre-defined amount of waste primarily includes large solid mass of waste along with liquid content. In general, the apparatus **100** is an industrial presser designed to press and dehydrate the pre-defined amount of waste.

The apparatus **100** includes a main frame **102**, a body **104**, a plurality of linkage plates **106**, a twin screw assembly **103** and a plurality of mesh screens **105**. In addition, the apparatus **100** includes an inlet **112**, a gear box assembly **114**, a chain and sprocket assembly **116** and a driving unit **118** (shown in **FIG. 1B** and **FIG. 1C**). In addition, the apparatus **100** includes an outlet **120** and a press housing **122** (shown in **FIG. 1B** and **FIG. 1C**). The above mentioned parts of the apparatus **100** are designed and assembled to perform pressing and dehydrating of the pre-defined amount of waste.

Further, the apparatus **100** is substantially positioned along a longitudinal axis. The apparatus **100** is rigidly supported by the main frame **102**. The main frame **102** is a metallic frame positioned to provide support to the apparatus **100**. Further, the main frame **102** includes a plurality of balance points. Each of the plurality of balance points is distributed discreetly across the main frame **102**. Moreover, the main frame **102** includes a first section **102a** for holding the body **104** of the apparatus **100**. In addition, the main frame **102** includes a second section for holding the driving unit **118** (shown in the **FIG. 1B** and **FIG. 1C**).

The main frame **102** has a pre-defined length (D) (shown in **FIG. 1B**) to rigidly support the apparatus **100**. In an embodiment of the present disclosure, the pre-defined length is

3680mm. In another embodiment of the present disclosure, the pre-defined length is 4010mm. In yet another embodiment of the present disclosure, the pre-defined length is 5700mm.

The body **104** is aligned along the longitudinal axis of the apparatus **100**. The body **104** includes a plurality of vertical rigid supports **104a-104h** and one or more horizontal rigid supports **104i**. The plurality of vertical rigid supports **104a-104h** is mounted perpendicular to the longitudinal axis of the apparatus **100**. In addition, the plurality of vertical rigid supports **104a-104h** is mounted vertically to the main frame **102** of the apparatus **100**. The plurality of vertical rigid supports **104a-104h** provides vertical support to the apparatus **100**. Moreover, the one or more horizontal rigid supports **104i** are mounted along the longitudinal axis of the apparatus **100**.

Furthermore, the body **104** is mechanically linked to the main frame **102** through the plurality of linkage plates **106**. Moreover, the plurality of linkage plates **106** is horizontally positioned on the main frame **102**. The plurality of linkage plates **106** is assembled discreetly across the main frame **102**. Moreover, the plurality of linkage plates **106** is a metallic plate designed to provide a rigid and flat base for assembled parts of the apparatus **100**. The body **104** includes a first plurality of holes. In addition, each linkage plate of the plurality of linkage plates **106** has a second plurality of holes designed to couple with a mountable part of the apparatus **100**. In an embodiment of the present disclosure, the body **104** is the mountable part of the apparatus **100**. The second plurality of holes of each linkage plate of the plurality of linkage plates **106** is aligned with the first plurality of holes of the body **104**. Moreover, the body **104** is mechanically linked through insertion of a plurality of bolts inside the aligned first plurality of holes and the second plurality of holes.

Furthermore, a capacity to process the pre-defined amount of waste is based on a material handling capacity of the inlet **112** (as shown in **FIG. 1B** and **FIG. 1C**). In an embodiment of the present disclosure, the capacity of the apparatus **100** to process the pre-

defined amount of waste is 350 tons per day. In another embodiment of the present disclosure, the capacity to process the pre-defined amount of the organic waste is 400 tons per day. In yet another embodiment of the present disclosure, the capacity to process the pre-defined amount of the organic waste is 800 tons per day.

5           Going further, the plurality of mesh screens **105** is rigidly linked to the body **104** along the longitudinal axis. The plurality of mesh screens is linked to the body **104** through the plurality of vertical rigid supports **104a-104h**. In addition, the plurality of mesh screens is linked to the body **104** through the one or more horizontal rigid supports **104i**. Moreover, the plurality of mesh screens **105** encapsulates the twin screw assembly **103**. Each mesh screen of  
10 the plurality of mesh screens **105** has a pre-defined shape. In an embodiment of the present disclosure, the pre-defined shape of the plurality of mesh screens **105** is cylindrical. In another embodiment of the present disclosure, the pre-defined shape of the plurality of mesh screens **105** is cuboidal. In yet another embodiment of the present disclosure, each of the plurality of mesh screens **105** may have any suitable shape.

15           **FIG. 1B** illustrates a side profile view of the apparatus of the **FIG. 1A**, in accordance with an embodiment of the present disclosure. The inlet **112** is vertically mounted on the body **104** of the apparatus **100**. The inlet **112** includes ingress cross-sectional opening **112a** for receiving the pre-defined amount of waste. In addition, the inlet **112** includes an egress cross-sectional opening **112b** for transferring the pre-defined amount of waste to the twin screw  
20 assembly **103**. In an embodiment of the present disclosure, the ingress cross-sectional opening **112a** is positioned above the egress cross-sectional opening **112b**.

Further, the pre-defined amount of waste is gravitationally fed to the twin screw assembly **103** through the inlet **112**. The pre-defined amount of waste is trapped between a first screw **124** and a second screw **126** (shown in **FIG. 1C**) of the twin screw assembly **103**.  
25 Moreover, the twin screw assembly **103** compresses the pre-defined amount of waste with each

rotation. In addition, the twin screw assembly **103** compresses the pre-defined amount of waste efficiently at a pre-defined speed of rotation. The pre-defined speed of rotation is controlled by the gear box assembly **114**. The gear box assembly **114** is coupled to a first screw shaft **126a** and a second screw shaft **128a** (shown in **FIG. 1C**) of the twin screw assembly **103**. In addition, the gear box assembly **114** is coupled to the chain and sprocket assembly **116**. Moreover, the gear box **114** receives power from the driving unit **118**. The gear box **114** receives the power from the driving unit **118** through the chain and sprocket assembly **116**.

The driving unit **118** is positioned adjacent to the body **104** of the apparatus **100**. In an embodiment of the present disclosure, the driving unit **118** is an electric motor. In another embodiment of the present disclosure the driving unit **118** is an engine. The driving unit **118** includes a driving shaft **118a** and a driving unit mount **118b**. The driving unit **118** is coupled with the driving shaft **118a**. The driving unit **118** is configured to supply the power to the twin screw assembly **103** at a pre-defined rate of rotation. In addition, the driving shaft **118a** is coupled to the chain and sprocket assembly **116**. Moreover, the chain and sprocket assembly **116** is configured to transfer the power to the gear box **114**.

In an embodiment of the present disclosure, the driving unit **118** is a direct current based motor. In another embodiment of the present disclosure, the driving unit **118** is an alternating current motor. Moreover, the pre-defined rate of rotation of the driving unit **118** may be controlled in any manner. In an embodiment of the present disclosure, the driving unit **118** is controlled through an automatic feedback based controller. In another embodiment of the present disclosure, the driving unit **118** is controlled through a manual switch based controller.

Furthermore, the driving unit **118** is mounted on the driving unit mount **118b**. The driving unit mount **118b** is positioned adjacent to the body **104** and mounted on the first section of the main frame **102**. The driving unit mount **118b** includes a plurality of holders

designed to mount the driving unit **118**. Moreover, the outlet **120** includes a press liquid outlet **120a** and a press solid outlet **120b**. The press liquid outlet **120a** is mechanically linked to the main frame **102** of the apparatus **100**. The press liquid outlet **120a** is configured to expel a compressed liquid content of the pre-defined amount of waste. In addition, the press solid outlet **120b** is mechanically linked to the main frame **102** at the second end **110** of the body **104**. The press solid outlet **120b** is configured to expel a compressed solid waste of the pre-defined amount of waste.

Further, the press housing **122** encloses the body **104**, the twin screw assembly **103** and the plurality of mesh screens **105**. The press housing **122** has a pre-defined shape. In an embodiment of the present disclosure, the pre-defined shape of the plurality of mesh screens **105** is cylindrical. In another embodiment of the present disclosure, the pre-defined shape of the plurality of mesh screens **105** is cuboidal. In yet another embodiment of the present disclosure, each of the plurality of mesh screens **105** may have any suitable shape. Further, the press housing **122** is made of a metal or an alloy. In an embodiment of the present disclosure, the metal used for construction of the press housing **122** is steel. In another embodiment of the present disclosure, the metal used for construction of the press housing **122** is galvanized iron. In yet another embodiment of the present disclosure, any suitable metal or alloy may be used for the construction of the press housing **122**.

**FIG. 1C** illustrates a rear profile view of the apparatus of the **FIG. 1A**, in accordance with another embodiment of the present disclosure. The first screw **124** and the second screw **126** extends outside the body **104**. A first annular base plate **128** supports the first screw **124**. In addition, the first annular base plate **128** is configured to align properly with the first screw **124**. Moreover, a second annular base plate **130** supports the second screw **126**. In addition, the second annular base plate **130** is configured to align properly with the second screw **126**.



Furthermore, the apparatus **100** has a pre-defined height (shown as B in **FIG. 1B**), a pre-defined length (shown as A in **FIG. 1B**) and a pre-defined width (shown as C in **FIG. 1C**). In an embodiment of the present disclosure, the apparatus **100** has the pre-defined height (B) of 2110 millimeters, the pre-defined length (A) of 4565 millimeters and the pre-defined width (C) of 1315 millimeters. In another embodiment of the present disclosure, the apparatus **100** has the pre-defined height (B) of 2115 millimeters, the pre-defined length (A) of 4850 millimeters and the pre-defined width (C) of 1330 millimeters. In yet another embodiment of the present disclosure, the apparatus **100** has the pre-defined height (B) of 2650 millimeters, the pre-defined length (A) of 6850 millimeters and the pre-defined width (C) of 1840 millimeters.

In addition, the driving unit **118** operating the twin screw assembly **103** in the apparatus **100** consumes a pre-defined amount of power. In an embodiment of the present disclosure, the pre-defined amount of the power is 37 kilowatt for the capacity of 350 tons per day. In another embodiment of the present disclosure, the pre-defined amount of power is 45 kilowatt for the capacity of 400 tons per day. In yet another embodiment of the present disclosure, the pre-defined amount of power is 55 kilowatts for the capacity of 800 tons per day.

**FIG. 2A** illustrates a perspective view of the twin screw assembly **103** of the apparatus of the **FIG. 1A**, in accordance with an embodiment of the present disclosure. The twin screw assembly **103** includes the first screw **124** and the second screw **126**. The first screw **124** and the second screw **126** are positioned along the longitudinal axis of the apparatus **100**. Further, the first screw **124** and the second screw **126** include a first end **202** and a second end **204**. In an embodiment of the present disclosure, the first end **202** is a near end. In an embodiment of the present disclosure, the second end **204** is a far end.

Further, the first screw **124** includes a first screw shaft **206** and a first plurality of helical ridges **208**. The first screw shaft **206** extends from the first end **202** to the second end **204**. Moreover, the first screw shaft **206** has a first pre-defined size at the first end **202**. In

addition, the first screw shaft **206** has a second pre-defined size at the second end **204**. In an embodiment of the present disclosure, the first pre-defined size at the first end **202** is greater than the second pre-defined size at the second end **204** (shown in **FIG. 2B**). Moreover, the first screw shaft **206** is coupled to the gear box assembly **114**.

5           The first plurality of helical ridges **208** is mounted on the first screw shaft **206**. In an embodiment of the present disclosure, the first plurality of helical ridges **208** has a right hand thread. In another embodiment of the present disclosure, the first plurality of helical ridges **208** has a left hand thread. Furthermore, the first plurality of helical ridges **208** has a first pre-defined progressive pitch. The first pre-defined progressive pitch varies from the first end **202**  
10 to the second end **204**. In an embodiment of the present disclosure, the first pre-defined progressive pitch is  $120^\circ$  at the first end **202**. In an embodiment of the present disclosure, the first pre-defined progressive pitch is  $95^\circ$  at the second end **204**.

Further, the second screw **126** includes a second screw shaft **210** and a second plurality of helical ridges **212**. The second screw shaft **210** extends from the first end **202** to the second  
15 end **204**. Moreover, the second screw shaft **210** has a third pre-defined size at the first end **202**. In addition, the second screw shaft **206** has a fourth pre-defined size at the second end **204**. In an embodiment of the present disclosure, the third pre-defined size at the first end **202** is greater than the fourth pre-defined size at the second end **204** (shown in **FIG. 2B**). Moreover, the second screw shaft **210** is coupled to the gear box assembly **114**.

20           The second plurality of helical ridges **212** is mounted on the second screw shaft **210**. In an embodiment of the present disclosure, the second plurality of helical ridges **212** has a left hand thread. In another embodiment of the present disclosure, the second plurality of helical ridges **212** has a right hand thread. Furthermore, the second plurality of helical ridges **212** has a second pre-defined progressive pitch. The second pre-defined progressive pitch varies from the  
25 first end **202** to the second end **204**. In an embodiment of the present disclosure, the second

pre-defined progressive pitch is  $120^\circ$  at the first end **202**. In an embodiment of the present disclosure, the second pre-defined progressive pitch is  $95^\circ$  at the second end **204**. In an embodiment of the present disclosure, the first plurality of helical ridges **208** and the second plurality of helical ridges **212** partially overlap each other.

5           **FIG. 3** illustrates a part perspective view of the plurality of mesh screens **105** of the apparatus of **FIG. 1A**, in accordance with an embodiment of the present disclosure. The plurality of mesh screens **105** is rigidly linked to the body **104** along the longitudinal axis (as shown in **FIG. 1A**). The plurality of mesh screens **105** is linked to the body **104** through the plurality of vertical rigid supports **104a-104h** (as shown in **FIG. 1A**). In addition, the plurality  
10 of mesh screens **105** is linked to the body **104** through the one or more horizontal rigid supports **104i** (as shown in **FIG. 1A**). Moreover, the plurality of mesh screens **105** encapsulates the twin screw assembly **103**. The plurality of mesh screens **105** is configured to remove the compressed liquid content of the pre-defined amount of waste. In an embodiment of the present disclosure, the plurality of mesh screens **105** is a stainless steel mesh screen.

15           Further, the plurality of mesh screens **105** includes a primary mesh screen **302** and a secondary mesh screen **304**. In an embodiment of the present disclosure, the secondary mesh screen **304** surrounds the primary mesh screen **302** circumferentially. The primary mesh screen **302** has a first plurality of fishers. The first plurality of fishers has a first pre-defined nominal diameter range. In an embodiment of the present disclosure, the first pre-defined nominal  
20 diameter range is 2mm-4mm. Moreover, the secondary mesh screen **304** has a second plurality of fishers. The second plurality of fishers has a second pre-defined nominal diameter range. In an embodiment of the present disclosure, the second pre-defined nominal diameter range is 6mm-8mm.

**FIG. 4** illustrates a side profile view of another apparatus **400** for drying the pre-defined  
25 amount of waste, in accordance with an embodiment of the present disclosure. The apparatus

**400** is a mechanical machine configured to collect and dry the pre-defined amount of the waste. The apparatus **400** utilizes indirect dry steam to kill bacteria and viruses present in the pre-defined amount of waste. In general, the apparatus **400** is an industrial dryer designed to dry the pre-defined amount of waste.

5 Further, the apparatus **400** includes a machinery frame **402**, a heating chamber **401**, a meal inlet **404**, a tumbler assembly **403** (shown in **FIG. 5**) and a motor **406**. In addition, the apparatus **400** includes a steam inlet **408**, a steam outlet **410**, a processed material outlet **412** and a dryer housing **414**. The apparatus **400** is rigidly supported by the machinery frame **402**. The machinery frame **402** is a metallic frame positioned to provide support to the apparatus **400**.

10 Further, the meal inlet **402** is mounted vertically to the heating chamber **401**. The meal inlet includes a feed inlet section **404a** and a feed discharge section **404b**. The meal inlet **404** receives the pre-defined amount of waste through the feed inlet section **404a**. In addition, the meal inlet **404** transfers the pre-defined amount of waste to the heating chamber **401** through the feed discharge section **404b**. In an embodiment of the present disclosure, the feed inlet  
15 section **404a** and the feed discharge section **404b** of the meal inlet **404** has a rectangular cross-section. It may be noted that the meal inlet **404** has a rectangular cross-section; however, those skilled in the art would appreciate that the feed inlet section **404a** and the feed discharge section **404b** of the meal inlet **404** may have any cross section. The feed inlet section **404a** of the meal inlet **404** is open vertically upwards. Moreover, the heating chamber **401** is a metallic  
20 chamber positioned adjacent to the length of the apparatus **400**. In addition, the heating chamber **401** is rigidly linked to the machinery frame **402**.

The heating chamber **401** is a hollow cylinder with a pre-defined nominal diameter. In an embodiment of the present disclosure, the pre-defined nominal diameter is 2880mm. In addition, the heating chamber **401** has a pre-defined heating surface area. In an embodiment of  
25 the present disclosure, the pre-defined heating surface area is 370 square meter. In another

embodiment of the present disclosure, the pre-defined heating surface area is 422 square meter. In addition, the weight of the apparatus **400** depends on the material handling capacity of the heating chamber **401**. In an embodiment of the present disclosure, the weight of the apparatus **400** is 28000 kilograms. In another embodiment of the present disclosure, the weight  
5 of the apparatus **400** is 30000 kilograms.

Further, the heating chamber **401** encloses the tumbler assembly **403** (shown in **FIG. 5**). The tumbler assembly **403** is positioned along a longitudinal axis of the heating chamber **401**. The tumbler assembly **403** (shown in **FIG. 5**) is configured to dry the pre-defined amount of waste. In addition, the tumbler assembly **403** (shown in **FIG. 5**) rotates at a pre-defined speed  
10 to dry the pre-defined amount of waste. The tumbler assembly **403** (shown in **FIG. 5**) is connected to the motor **406**. The motor **406** is an electric motor designed to rotate at a pre-defined speed. Moreover, the motor **406** includes a motor shaft. The motor shaft is attached to the tumbler assembly **403** (shown in **FIG. 5**). The motor shaft is positioned to rotate the tumbler assembly **403** at a pre-defined range of a speed of rotation.

15 In an embodiment of the present disclosure, the motor **406** is an alternating current motor. In another embodiment of the present disclosure, the motor **406** is a direct current motor. In addition, the motor **406** is connected through a motor controller. The motor controller directs electric power and provides regulated current to the motor **406**. The regulated current determines a rate of rotation of the motor **406**. In an embodiment of the  
20 present disclosure, the motor controller is a manual controller. In another embodiment of the present disclosure, the motor controller is an automatic controller.

Going further, the tumbler assembly **403** is mechanically connected to the steam inlet **408**. The steam inlet **408** is positioned at a third end (shown in **FIG. 5**) of the tumbler assembly **403**. The steam inlet **408** collects a pre-defined amount of dry steam from a steam  
25 boiler. The steam inlet **408** is designed to collect the pre-defined amount of dry steam inside a

hollow shaft (shown in **FIG. 5**) of the tumbler assembly **403**. Moreover, the steam outlet **410** is positioned at a fourth end (shown in **FIG. 5**) of the tumbler assembly **403**. The steam outlet **410** is positioned along an axis synchronized with the longitudinal axis of the heating chamber **401**. Further, the steam outlet **410** is internally connected to the tumbler assembly **403** (shown in **FIG. 5**). The steam outlet **410** transfers a condensed steam present inside the tumbler assembly **403** to one or more feeding pipes. In addition, the one or more feeding pipes transfer the condensed steam from the tumbler assembly **403** to the steam boiler.

Further, the processed material outlet **412** is substantially attached to a bottom of the heating chamber **401**. In addition, the processed material outlet **412** faces downwards with an axis perpendicular to the longitudinal axis of the heating chamber **401**. Moreover, the processed material outlet **412** is characterized by a processed material opening. The processed material opening has a rectangular cross section. In an embodiment of the present disclosure, the processed material opening of the processed material outlet **412** may have any cross-section. Further, the processed material outlet **412** is designed to eject the pre-defined amount of organic waste subjected to drying treatment.

Furthermore, the dryer housing **414** is positioned adjacent to the longitudinal axis of the heating chamber **401**. The dryer housing **414** is a metallic case designed to enclose the tumbler assembly **403**. Moreover, the apparatus **400** has a pre-defined height (shown as B in **FIG. 4**) and a pre-defined length (shown as A in **FIG. 4**). In an embodiment of the present disclosure, the apparatus **400** has the pre-defined height (B) of 10080 millimeters and the apparatus length (A) of 11600 millimeters. In another embodiment of the present disclosure, the apparatus **400** has the pre-defined height (B) of 11080 millimeters and the pre-defined length (A) of 12600 millimeters.

Going further, the motor **406** operating the tumbler assembly **403** in the apparatus **400** consumes a pre-defined amount of power. In an embodiment of the present disclosure, the pre-

defined amount of the power is 90 kilowatt. In another embodiment of the present disclosure, the pre-defined amount of power is 110 kilowatt.

**FIG. 5A** illustrates a schematic view of the tumbler assembly **403** of the apparatus of the **FIG. 4**, in accordance with an embodiment of the present disclosure. The tumbler assembly **403** includes a third end **502**, a fourth end **504**, a hollow shaft **506**, a plurality of group of concentric rings **508**, a plurality of reinforcement members **510a-510b**, a plurality of return pipes **512a-512b** and a plurality of angular blocks **513**. Moreover, a plurality of parts of the tumbler assembly **403** is designed to efficiently dry the pre-defined amount of waste.

The hollow shaft **506** of the tumbler assembly **403** is positioned along an axis synchronized with the longitudinal axis of the heating chamber **401**. The hollow shaft **506** extends from the third end **502** to the fourth end **504** of the tumbler assembly **403**. The hollow shaft **506** is designed to receive dry steam from the steam inlet **408** of the apparatus **400**. Moreover, the hollow shaft **506** is designed to receive steam at a pre-defined pressure. In an embodiment of the present disclosure, the pre-defined pressure is 6 bars. In addition, the hollow shaft **506** is designed to transfer the condensed steam to the steam outlet **410** of the apparatus **400**. Moreover, the hollow shaft **506** is designed to disperse the steam inside the plurality of group of concentric rings **508** of the tumbler assembly **403**. In an embodiment of the present disclosure, the hollow shaft **506** is made of non-alloy quality steel. In another embodiment of the present disclosure, the hollow shaft **506** is made of any suitable material. In an embodiment of the present disclosure, the hollow shaft has a pre-defined diameter of 610mm and a pre-defined length of 9720mm.

The plurality of group of concentric rings **508** is mechanically mounted to the hollow shaft **506**. In an embodiment of the present disclosure, the plurality of group of concentric rings **508** is mounted perpendicular to a longitudinal axis of the hollow shaft **506**. In another embodiment of the present disclosure, the plurality of group of concentric rings **508** is oriented

slightly off-center with respect to the hollow shaft **506**. In yet another embodiment of the present disclosure, the plurality of group of concentric rings **508** is mounted at a pre-defined angular range with respect to the longitudinal axis of the hollow shaft **506**. In an embodiment of the present disclosure, the pre-defined angular range is 85°-95°.

5 Further, each of the plurality of group of concentric rings **508** includes a plurality of concentric rings **508a-508g** (as shown in **FIG. 5B**). Each of the plurality of group of concentric rings **508** has a pre-defined amount of the plurality of concentric rings. In an embodiment of the present disclosure, the pre-defined amount of the plurality of concentric rings **508a-508g** is in a range of 3-20. Each concentric ring of the plurality of concentric rings  
10 **508a-508g** is designed to disperse the steam for efficient drying of the pre-defined amount of waste (as shown in **FIG. 5B**). In addition, each concentric ring of the plurality of concentric rings **508a-508g** is connected to the hollow shaft **506** through a plurality of pipes. The plurality of pipes is designed to transfer the steam from the hollow shaft **506** to each concentric ring of the plurality of concentric rings **508a-508g** (as shown in **FIG. 5B**). Moreover, each  
15 concentric ring of the plurality of concentric rings **508a-508g** encapsulates a steam injector for regulating steam.

In an embodiment of the present disclosure, each concentric ring of the plurality of concentric rings **508a-508g** is made of non-alloy quality steel. In an embodiment of the present disclosure, each concentric ring of the plurality of concentric rings **508a-508g** has a pre-defined  
20 tube diameter of 60mm (as shown in **FIG. 5C**). In an embodiment of the present disclosure, concentric ring **508a** has a pre-defined nominal diameter of 2540 mm. In an embodiment of the present disclosure, concentric ring **508b** has a pre-defined nominal diameter of 2270 mm. In an embodiment of the present disclosure, concentric ring **508c** has a pre-defined nominal diameter of 2000 mm. In an embodiment of the present disclosure, concentric ring **508d** has a  
25 pre-defined nominal diameter of 1730 mm. In an embodiment of the present disclosure,



concentric ring **508e** has a pre-defined nominal diameter of 1460 mm. In an embodiment of the present disclosure, concentric ring **508f** has a pre-defined nominal diameter of 1190 mm. In an embodiment of the present disclosure, concentric ring **508g** has a pre-defined nominal diameter of 920 mm. In addition, each concentric ring of the plurality of concentric rings **508a-508g** is connected to the plurality of reinforcement members **510a-510b**. Each reinforcement member of the plurality of reinforcement members **510a-510b** is designed to provide rigid strength to the tumbler assembly **403**. In addition, each reinforcement member of the plurality of reinforcement members **510a-510b** is rigidly linked to each concentric ring of the plurality of concentric rings **508a-508g**. In an embodiment of the present disclosure, each reinforcement member of the plurality of reinforcement members **510a-510b** is made of hot rolled steel.

Furthermore, the plurality of return pipes **512a-512b** (as shown in **FIG. 5B**, **FIG. 5C**) is mechanically connected to each group of the plurality of group of concentric rings **508**. In an embodiment of the present disclosure, each return pipe of the plurality of return pipes **512a-512b** is made of the non-alloy quality steel. In another embodiment of the present disclosure, each return pipe of the plurality of return pipes **512a-512b** can be made of any suitable material. In addition, each return pipe of the plurality of return pipes **512a-512b** is connected at a pre-defined distance from each other. In an embodiment of the present disclosure, the pre-defined distance is 50 mm. The plurality of return pipes **512a-512b** (as shown clearly in **FIG. 5C**) is designed to capture and return the condensed steam to the hollow shaft **506**. In an embodiment of the present disclosure, each return pipe of the plurality of return pipes **512a-512b** has a pre-defined nominal diameter of 90 mm (as shown in **FIG. 5C**). Moreover, each return pipe of the plurality of return pipes **512a-512b** has a pre-defined wall thickness. In an embodiment of the present disclosure, the pre-defined wall thickness is 8mm. In addition, each return pipe of the

plurality of return pipes **512a-512b** is made of a pre-defined material. In an embodiment of the present disclosure, the pre-defined material is a non-alloy quality steel.

The plurality of angular blocks **513** is mechanically mounted to each group of the plurality of group of concentric rings **508**. The plurality of angular blocks **513** is mounted at a plurality of angles and at a plurality of positions with respect to each group of the plurality of group of concentric rings **508**. The plurality of angular blocks **513** is designed to agitate and move the pre-defined amount of waste forward inside the apparatus **400**.

**FIG. 5D** illustrates a side sectional view of the tumbler assembly **403** of the apparatus of the **FIG. 4**, in accordance with an embodiment of the present disclosure. In addition, the **FIG. 5D** illustrates a detailed sectional view of the steam inlet **408** and the steam outlet **410** associated with the tumbler assembly **403**. The steam inlet **408** includes an inlet shaft **514**, a first inlet flange **516a**, a second inlet flange, a first inlet support **518a** and a second inlet support **518b**. Further, the inlet shaft **514** is a hollow cylindrical shaft designed to allow the steam to enter the hollow shaft **506** at the pre-defined pressure. The inlet shaft **514** is made of a pre-defined material. In an embodiment of the present disclosure, the pre-defined material is AISI 1050 carbon steel. In another embodiment of the present disclosure, the pre-defined material can be any suitable material.

Furthermore, the inlet shaft **514** includes a first inlet end **514a** and a second inlet end **514b**. In an embodiment of the present disclosure, the first inlet end **514a** and a second inlet end **514b** are positioned at a pre-defined distance of 613mm from each other. In addition, the inlet shaft **514** includes a section **A**, a section **B** and a section **C**. In an embodiment of the present disclosure, the section **A** has a pre-defined length of 253 mm and a pre-defined nominal diameter of 220 mm. In an embodiment of the present disclosure, the section **B** has a pre-defined length of 242 mm and a pre-defined nominal diameter of 250 mm. In an embodiment

of the present disclosure, the section **C** has a pre-defined length of 118 mm and a pre-defined nominal diameter of 240 mm.

The first inlet flange **516a** and the second inlet flange **516b** are mounted at the section **C** of the inlet shaft **514**. In an embodiment of the present disclosure, the first inlet flange **516a** and the second inlet flange **516b** are made of hot rolled steel. In another embodiment of the present disclosure, the first inlet flange **516a** and the second inlet flange **516b** can be made of any suitable material. In an embodiment of the present disclosure, the first inlet flange **516a** has a nominal diameter of 810 mm and a thickness of 38 mm. In an embodiment of the present disclosure, the second inlet flange **516b** has a nominal diameter of 810 mm and a thickness of 38 mm. Moreover, a pre-defined number of holes of pre-defined diameter are drilled circumferentially on the first inlet flange **516a** and the second inlet flange **516b**. In an embodiment of the present disclosure, the pre-defined number of holes is 24. In an embodiment of the present disclosure, the pre-defined diameter of each hole is 24 mm.

Furthermore, the first inlet support **518a** and the second inlet support **518b** are rigidly linked to the section **B**, the section **C**, the first inlet flange **516a** and the second inlet flange **516b**. The first inlet support **518a** and the second inlet support **518b** are designed to rigidly support the first inlet flange **516a** and the second inlet flange **516b**. In addition, the first inlet support **518a** and the second inlet support **518b** are positioned to rigidly fix the first inlet flange **516a** and the second inlet flange **516b**. In an embodiment of the present disclosure, the first inlet support **518a** and the second inlet support **518b** are made of the hot rolled steel. In another embodiment of the present disclosure, the first inlet support **518a** and the second inlet support **518b** can be made of any suitable material. In an embodiment of the present disclosure, each of the first inlet support **518a** and the second inlet support **518b** has a pre-defined thickness of 30 mm.

Going further, the steam outlet **410** includes an outlet shaft **520**, an outlet flange **522**, a first outlet support **524a** and a second outlet support **524b**. The outlet shaft **520** is a hollow cylindrical shaft designed to allow the steam to exit through the hollow shaft **506** at the pre-defined pressure. The outlet shaft **520** is made of a pre-defined material. In an embodiment of the present disclosure, the pre-defined material is AISI 1050 carbon steel. In another embodiment of the present disclosure, the pre-defined material can be any suitable material.

Furthermore, the outlet shaft **520** includes a first outlet end **520a** and a second outlet end **520b**. In an embodiment of the present disclosure, the first outlet end **520a** and a second outlet end **520b** are positioned at a pre-defined distance of 893mm from each other. In addition, the outlet shaft **520** includes a section **D**, section **E**, section **F**, section **G**, section **H** and section **I**. In an embodiment of the present disclosure, the section **D** has a pre-defined length of 118 mm and a pre-defined nominal diameter of 240 mm. In an embodiment of the present disclosure, the section **E** has a pre-defined length of 243.9 mm and a pre-defined nominal diameter of 250 mm. In an embodiment of the present disclosure, the section **F** has a pre-defined length of 117.2 mm and a pre-defined nominal diameter of 220 mm. In an embodiment of the present disclosure, the section **G** has a pre-defined length of 103.9 mm and a pre-defined nominal diameter of 210 mm. In an embodiment of the present disclosure, the section **H** has a pre-defined length of 250 mm and a pre-defined nominal diameter of 200mm. In an embodiment of the present disclosure, the section **I** has a pre-defined length of 60mm and a pre-defined nominal diameter of 180 mm.

The outlet flange **522** is mounted at the section **D** of the outlet shaft **520**. In an embodiment of the present disclosure, the outlet flange **522** is made of hot rolled steel. In another embodiment of the present disclosure, the outlet flange **522** can be made of any suitable material. In an embodiment of the present disclosure, the outlet flange **522** has a nominal diameter of 810mm and a thickness of 38mm. Moreover, a pre-defined number of holes of pre-

defined diameter are drilled circumferentially on the outlet flange **522**. In an embodiment of the present disclosure, the pre-defined number of holes is 24. In an embodiment of the present disclosure, the pre-defined diameter of each hole is 24 mm.

Furthermore, the first outlet support **524a** and the second outlet support **524b** are rigidly  
5 linked to the section **D**, the section **E** and the outlet flange **522**. The first outlet support **524a**  
and the second outlet support **524b** are designed to rigidly support the outlet flange **522**. In  
addition, the first outlet support **524a** and the second outlet support **524b** are positioned to  
rigidly fix the outlet flange **522**. In an embodiment of the present disclosure, the first outlet  
support **524a** and the second outlet support **524b** are made of the hot rolled steel. In another  
10 embodiment of the present disclosure, the first outlet support **524a** and the second outlet support  
**524b** can be made of any suitable material. In an embodiment of the present disclosure, each  
of the first outlet support **524a** and the second outlet support **524b** has a pre-defined thickness of  
30 mm.

Further, the present apparatus has several advantages over the prior art. The present  
15 apparatus provides compactly and sophisticatedly pressed and dried waste with an increased  
processing efficiency. Further, the apparatus derives a lower power with an increased output.  
Thus, the apparatus provides a higher return of investment and an easier finance of resources.  
Furthermore, the use of the apparatus has various ecological benefits. The apparatus decreases  
the volume of the waste. In addition, the apparatus provides a solution to the growing problem  
20 of large scale waste dumping. Ultimately, the apparatus leads to a reduction in emissions of  
greenhouse gases (GHG) and possibly a complete elimination of landfills.

The foregoing descriptions of specific embodiments of the present technology have  
been presented for purposes of illustration and description. They are not intended to be  
exhaustive or to limit the present technology to the precise forms disclosed, and obviously  
25 many modifications and variations are possible in light of the above teaching. The

embodiments were chosen and described in order to best explain the principles of the present technology and its practical application, to thereby enable others skilled in the art to best utilize the present technology and various embodiments with various modifications as are suited to the particular use contemplated. It is understood that various omissions and substitutions of  
5 equivalents are contemplated as circumstance may suggest or render expedient, but such are intended to cover the application or implementation without departing from the spirit or scope of the claims of the present technology.

While several possible embodiments of the invention have been described above and illustrated in some cases, it should be interpreted and understood as to have been presented  
10 only by way of illustration and example, but not by limitation. Thus, the breadth and scope of a preferred embodiment should not be limited by any of the above-described exemplary embodiments.

## WHAT IS CLAIMED IS:

1. An apparatus for pressing and dehydrating a pre-defined amount of waste, the apparatus comprising:

a main frame positioned for providing a rigid support to the apparatus, wherein the main frame being a metallic main frame;

a body mechanically linked to the main frame through a plurality of linkage plates, wherein the body being designed to support rotation of a twin screw assembly, wherein the body comprises:

a plurality of vertical rigid supports mounted perpendicular to a longitudinal axis of the apparatus, wherein the plurality of vertical rigid supports being mounted vertically to the main frame, wherein the plurality of vertical rigid supports provides vertical support to the apparatus; and

one or more horizontal rigid supports mounted horizontally along the longitudinal axis of the apparatus;

an inlet vertically mounted on the body, wherein the inlet comprises an ingress cross-sectional opening for receiving the pre-defined amount of waste and an egress cross-sectional opening for transferring the pre-defined amount of waste to the twin screw assembly;

the twin screw assembly mounted on the main frame and horizontally positioned on the main frame for rotation along the longitudinal axis of the apparatus, wherein the twin screw assembly being configured to press and dehydrate the pre-defined amount of waste; and

a plurality of mesh screens rigidly linked to the body along the longitudinal axis of the apparatus, wherein each mesh screen of the plurality of mesh screens comprises a plurality of

fishers for removing compressed liquid and wherein the plurality of mesh screens encapsulates the twin screw assembly.

2. The apparatus as recited in claim 1, wherein the main frame comprises a first section for holding the body and a second section for holding a driving unit.

3. The apparatus as recited in claim 1, wherein the twin screw assembly further comprises:

a first screw and a second screw positioned along the longitudinal axis of the apparatus, wherein the first screw and the second screw being mechanically coupled to a driving shaft of the driving unit through a chain and sprocket assembly, wherein the first screw and the second screw comprises a first end and a second end and wherein the first end being a near end and the second end being a far end; and

a plurality of helical ridges rigidly mounted on the first screw and the second screw, wherein each helical ridge of the plurality of helical ridges has a pre-defined progressive pitch varying from the first end to the second end.

4. The apparatus as recited in claim 3, wherein the pre-defined progressive pitch being  $120^\circ$  at the first end and wherein the pre-defined progressive pitch being  $95^\circ$  at the second end.

5. The apparatus as recited in claim 2, wherein the driving unit being positioned adjacent to the body and mounted on the second section of the main frame, wherein the driving unit being coupled to the chain and sprocket assembly.



6. The apparatus as recited in claim 2, wherein the driving unit comprises an electric motor assembly.

7. The apparatus as recited in claim 2, wherein the driving unit comprises an engine assembly.

8. The apparatus as recited in claim 1, wherein the plurality of mesh screens further comprises a primary mesh screen and a secondary mesh screen, wherein the secondary mesh screen surrounds the primary mesh screen circumferentially and wherein the plurality of mesh screens being a stainless steel mesh screen.

9. The apparatus as recited in claim 8, wherein the primary mesh screen comprises a first plurality of fishers of the plurality of fishers, wherein the first plurality of fishers have a first pre-defined nominal diameter range and wherein the first pre-defined nominal diameter range being 2mm-4mm.

10. The apparatus as recited in claim 8, wherein the secondary mesh screen comprises a second plurality of fishers of the plurality of fishers, wherein the second plurality of fishers have a second pre-defined nominal diameter range and wherein the second pre-defined nominal diameter range being 6mm-8mm.

11. The apparatus as recited in claim 1, further comprising an outlet for expelling a processed waste, wherein the outlet being positioned at the second end.

12. An apparatus for pressing and dehydrating a pre-defined amount of waste, the apparatus comprising:

a main frame positioned for providing a rigid support to the apparatus, wherein the main frame being a metallic main frame and wherein the main frame comprises a first section and a second section;

a body mechanically linked to the main frame through a plurality of linkage plates, wherein the body being designed to support rotation of a twin screw assembly, wherein the first section of the main frame holds the body, wherein the body comprises:

a plurality of vertical rigid supports mounted perpendicular to a longitudinal axis of the apparatus, wherein the plurality of vertical rigid supports being mounted vertically to the main frame, wherein the plurality of vertical rigid supports provides vertical support to the apparatus; and

one or more horizontal rigid supports mounted horizontally along the longitudinal axis of the apparatus;

an inlet vertically mounted on the body, wherein the inlet comprises an ingress cross-sectional opening for receiving the pre-defined amount of waste and an egress cross-sectional opening for transferring the pre-defined amount of waste to the twin screw assembly;

the twin screw assembly mounted on the main frame and horizontally positioned on the main frame for rotation along the longitudinal axis of the apparatus, wherein the twin screw assembly being configured to press and dehydrate the pre-defined amount of waste, wherein the twin screw assembly comprises:

a first screw and a second screw positioned along the longitudinal axis of the apparatus, wherein the first screw and the second screw being mechanically coupled to a driving shaft of a

driving unit through a chain and sprocket assembly, wherein the second section holds the driving unit, wherein the first screw and the second screw comprises a first end and a second end and wherein the first end being a near end and the second end being a far end; and

a plurality of helical ridges rigidly mounted on the first screw and the second screw, wherein each helical ridge of the plurality of helical ridges has a pre-defined progressive pitch varying from the first end to the second end;

a plurality of mesh screens rigidly linked to the body along the longitudinal axis of the apparatus, wherein each mesh screen of the plurality of mesh screens comprises a plurality of fishers for removing compressed liquid and wherein the plurality of mesh screens encapsulates the twin screw assembly.

13. The apparatus as recited in claim 12, wherein the pre-defined progressive pitch being  $120^\circ$  at the first end and wherein the pre-defined progressive pitch being  $95^\circ$  at the second end.

14. The apparatus as recited in claim 12, wherein the plurality of mesh screens further comprises a primary mesh screen and a secondary mesh screen, wherein the secondary mesh screen surrounds the primary mesh screen circumferentially and wherein the plurality of mesh screens being a stainless steel mesh screen.

15. The apparatus as recited in claim 14, wherein the primary mesh screen comprises a first plurality of fishers of the plurality of fishers, wherein the first plurality of fishers have a first pre-defined nominal diameter range and wherein the first pre-defined nominal diameter range being 2mm-4mm.

16. The apparatus as recited in claim 14, wherein the secondary mesh screen comprises a second plurality of fishers of the plurality of fishers, wherein the second plurality of fishers have a second pre-defined nominal diameter range and wherein the second pre-defined nominal diameter range being 6mm-8mm.

17. The apparatus as recited in claim 12, further comprising an outlet for expelling a processed waste, wherein the outlet being positioned at the second end.

18. An apparatus for pressing and dehydrating a pre-defined amount of waste, the apparatus comprising:

a main frame positioned for providing a rigid support to the apparatus, wherein the main frame being a metallic main frame and wherein the main frame comprises a first section for holding a body and a second section for holding a driving unit;

the body mechanically linked to the main frame through a plurality of linkage plates, wherein the body being designed to support rotation of a twin screw assembly, wherein the body comprises:

a plurality of vertical rigid supports mounted perpendicular to a longitudinal axis of the apparatus, wherein the plurality of vertical rigid supports being mounted vertically to the main frame, wherein the plurality of vertical rigid supports provides vertical support to the apparatus; and

one or more horizontal rigid supports mounted horizontally along the longitudinal axis of the apparatus;

an inlet vertically mounted on the body, wherein the inlet comprises an ingress cross-sectional opening for receiving the pre-defined amount of waste and an egress cross-sectional opening for transferring the pre-defined amount of waste to the twin screw assembly;

the twin screw assembly mounted on the main frame and horizontally positioned for rotation along the longitudinal axis of the apparatus, wherein the twin screw assembly being configured to press and dehydrate the pre-defined amount of waste, wherein the twin screw assembly comprises:

a first screw and a second screw positioned along the longitudinal axis of the apparatus, wherein the first screw and the second screw being mechanically coupled to a driving shaft of the

driving unit through a chain and sprocket assembly, wherein the first screw and the second screw comprises a first end and a second end and wherein the first end being a near end and the second end being a far end; and

a plurality of helical ridges rigidly mounted on the first screw and the second screw, wherein each helical ridge of the plurality of helical ridges has a pre-defined progressive pitch varying from the first end to the second end, wherein the pre-defined progressive pitch being  $120^\circ$  at the first end and wherein the pre-defined progressive pitch being  $95^\circ$  at the second end;

a plurality of mesh screens rigidly linked to the body along the longitudinal axis, wherein each mesh screen of the plurality of mesh screens comprises a plurality of fishers for removing compressed liquid, wherein the plurality of mesh screens encapsulates the twin screw assembly, wherein the plurality of mesh screens comprises a primary mesh screen and a secondary mesh screen, wherein the secondary mesh screen surrounds the primary mesh screen circumferentially and wherein the plurality of mesh screens being a stainless steel mesh screen.

19. The apparatus as recited in claim 18, wherein the primary mesh screen comprises a first plurality of fishers of the plurality of fishers, wherein the first plurality of fishers have a first pre-defined nominal diameter range and wherein the first pre-defined nominal diameter range being 2mm-4mm , wherein the secondary mesh screen comprises a second plurality of fishers of the plurality of fishers, wherein the second plurality of fishers have a second pre-defined nominal diameter range and wherein the second pre-defined nominal diameter range being 6mm-8mm.

20. The apparatus as recited in claim 18, further comprising an outlet for expelling a processed waste, wherein the outlet being positioned at the second end.

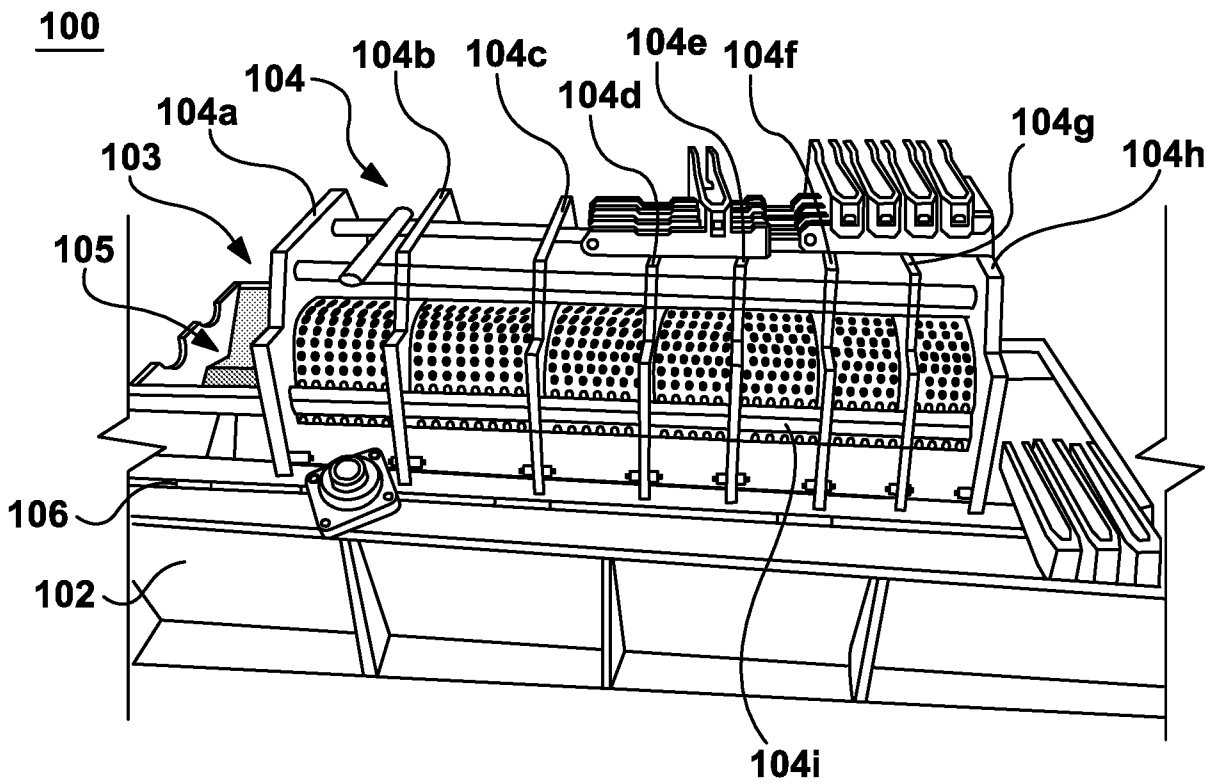

FIG. 1A

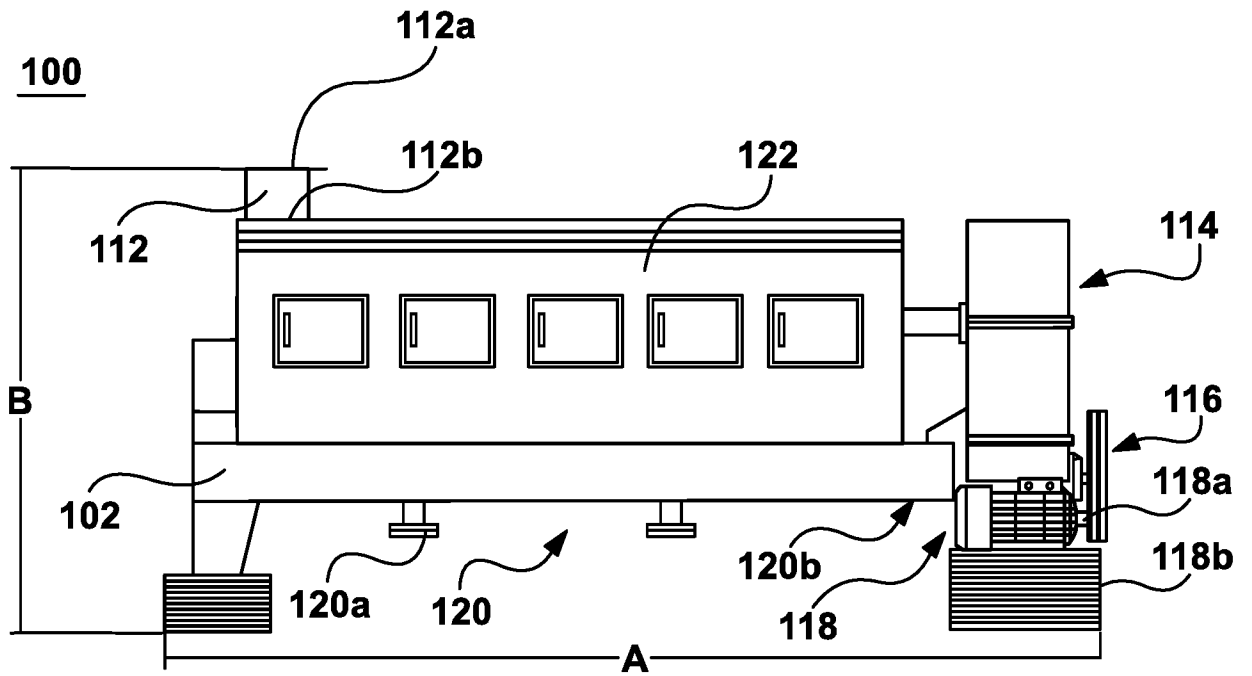

FIG. 1B



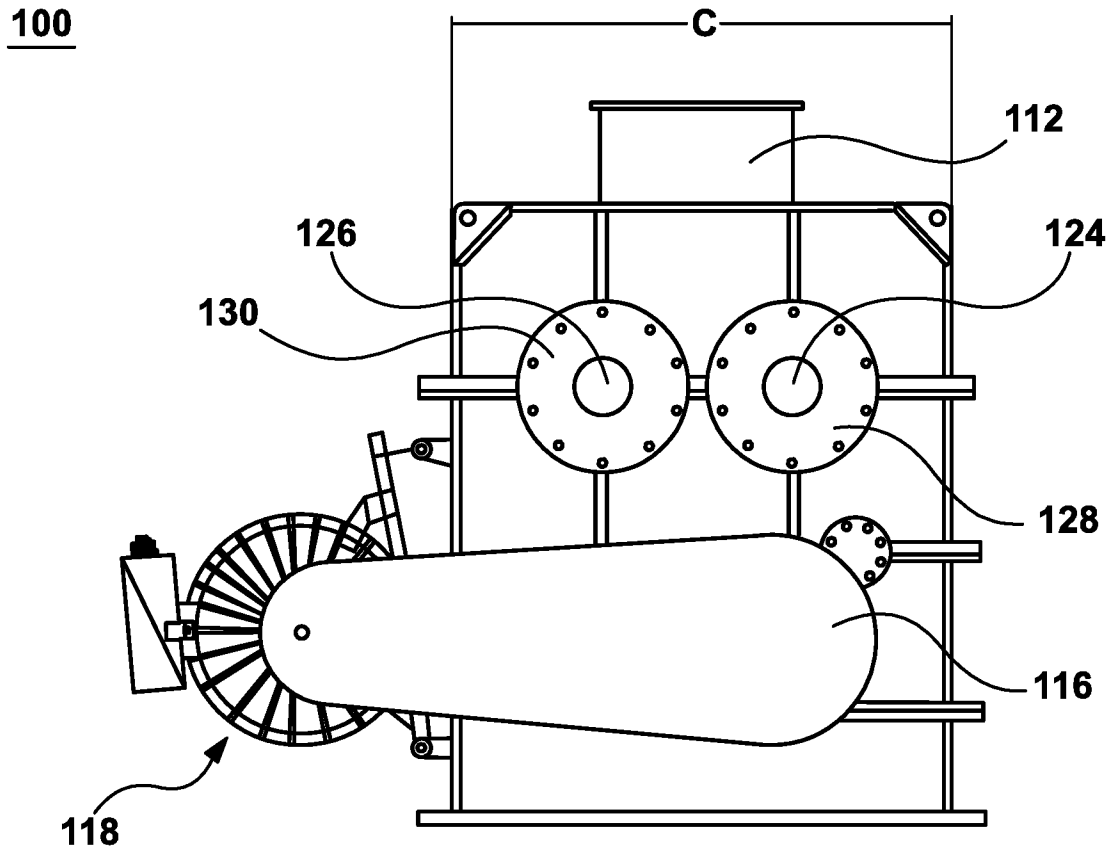

FIG. 1C

4/11

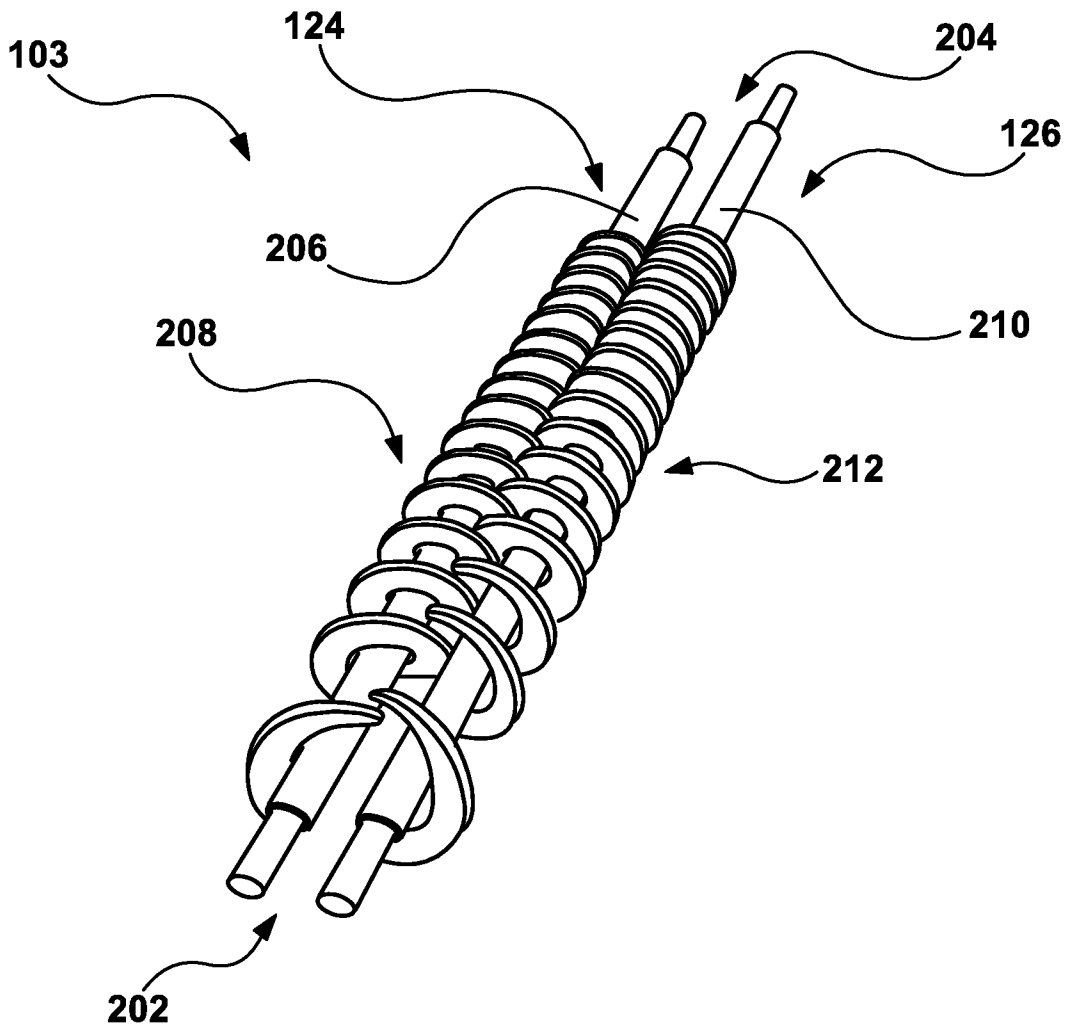

FIG. 2A

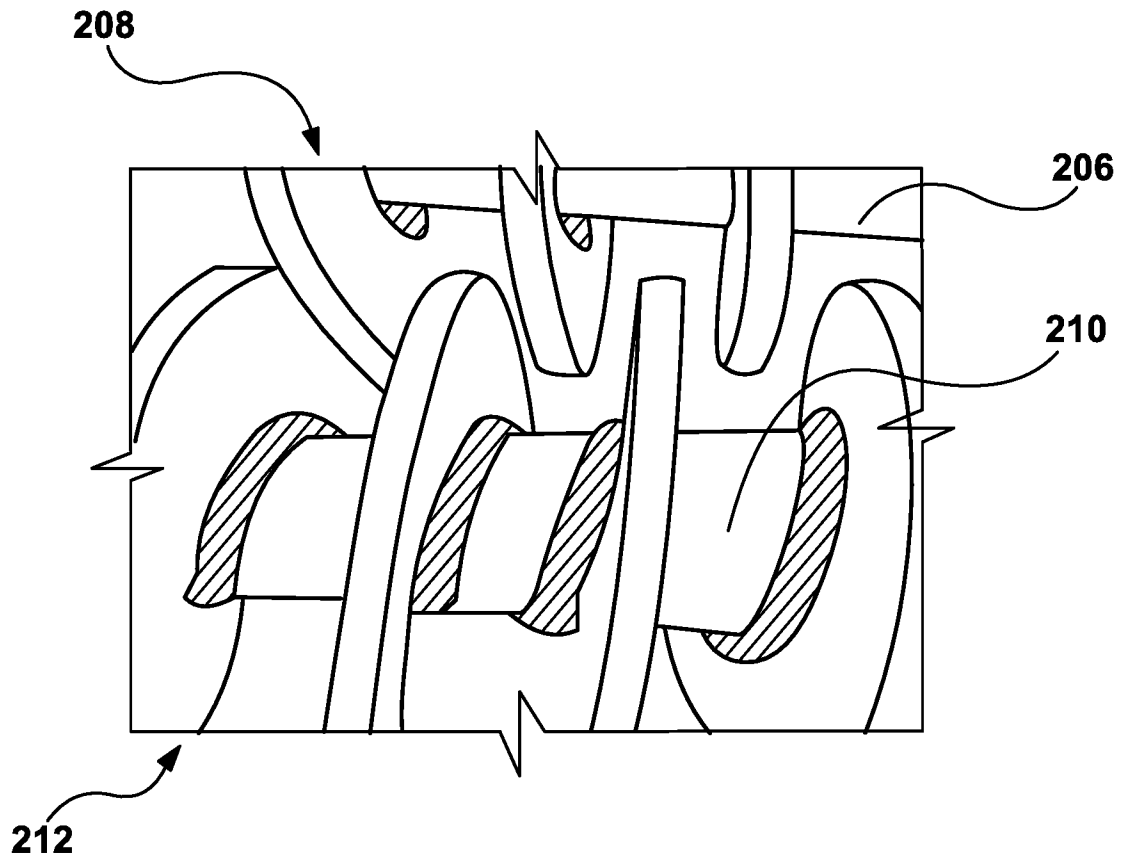

FIG. 2B

6/11

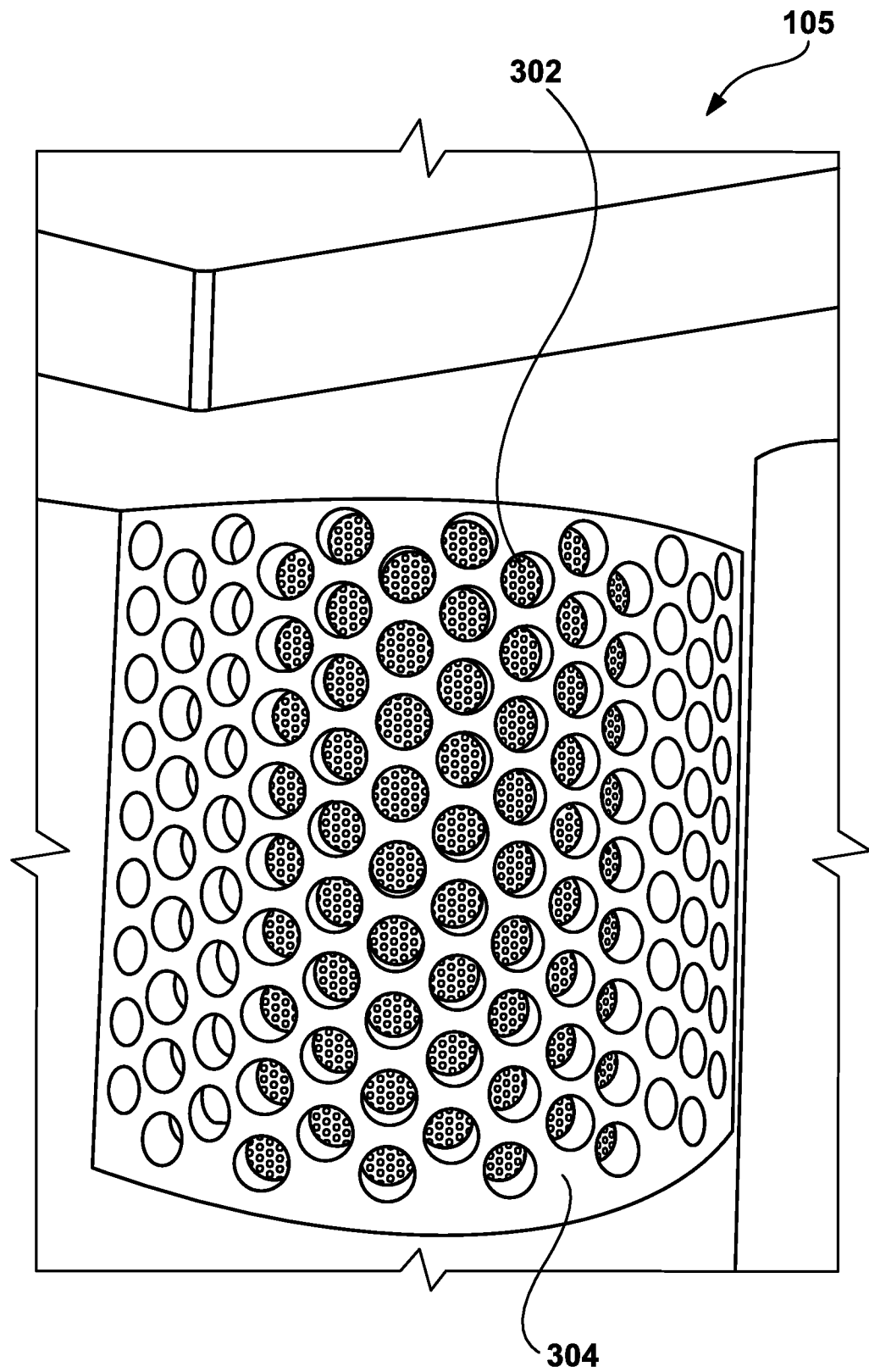

FIG. 3

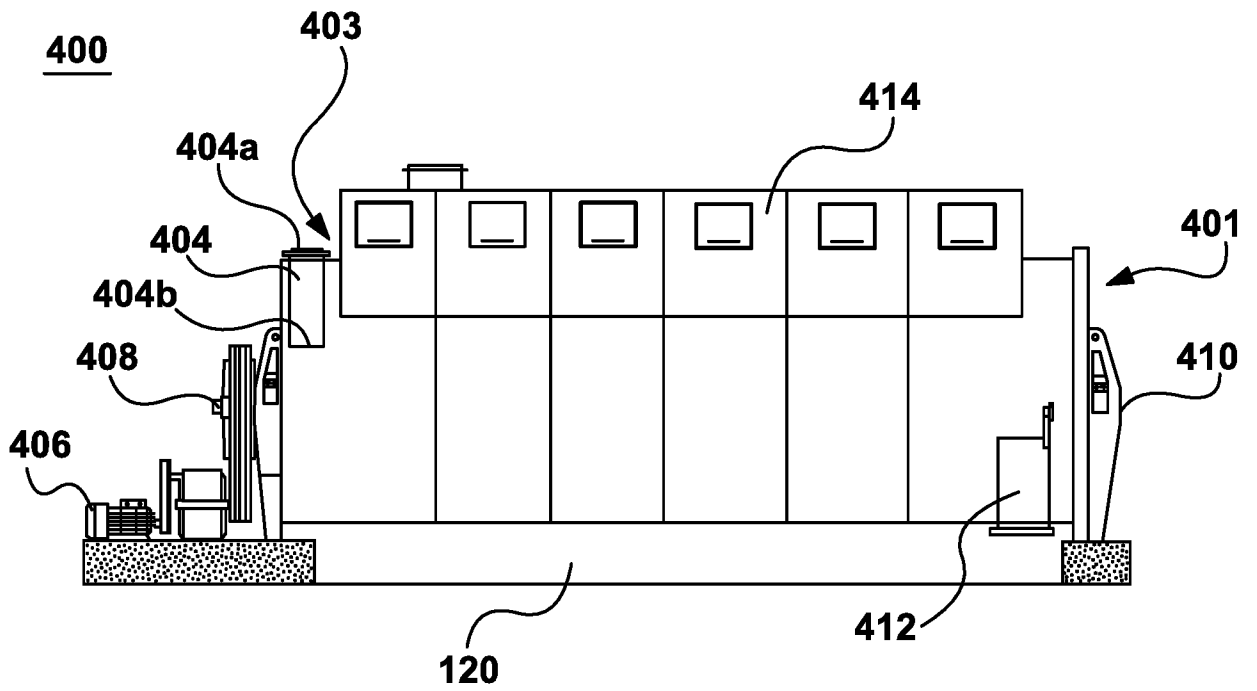

FIG. 4

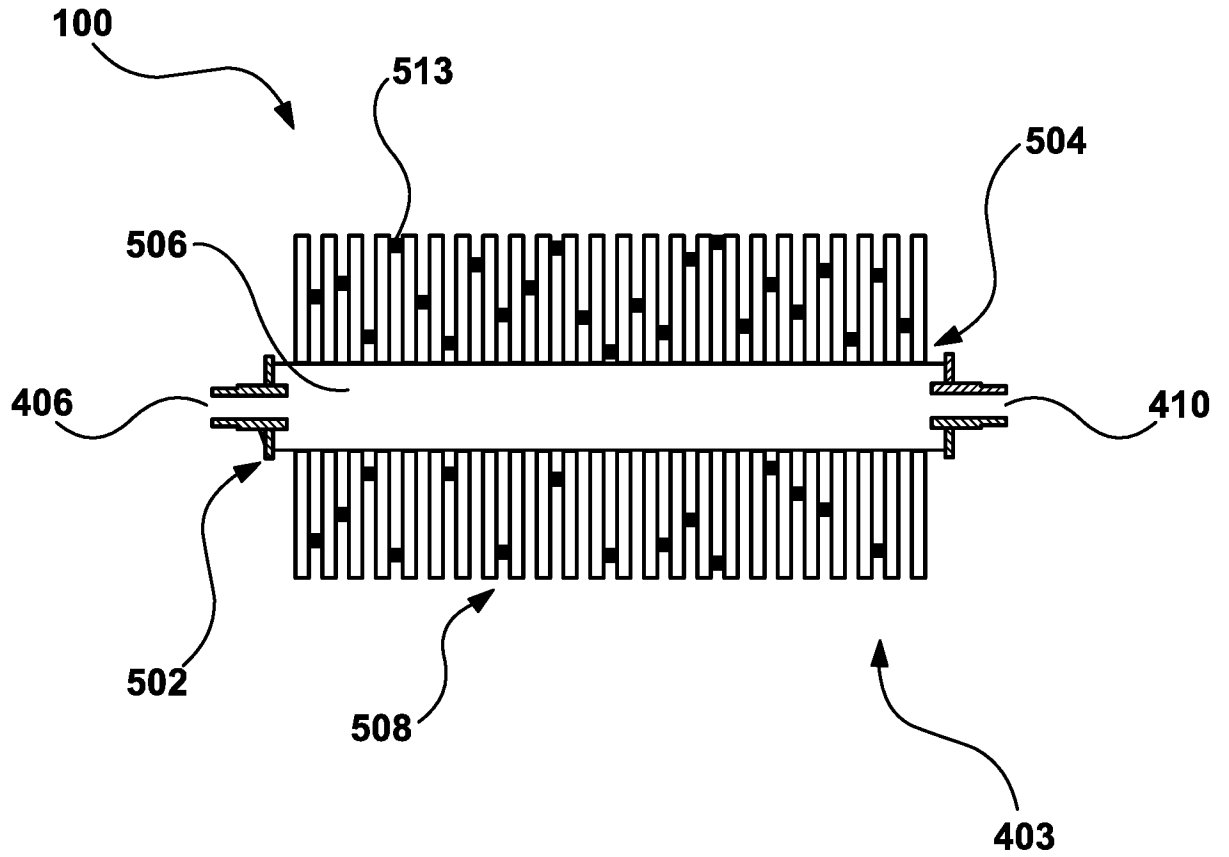

FIG. 5A

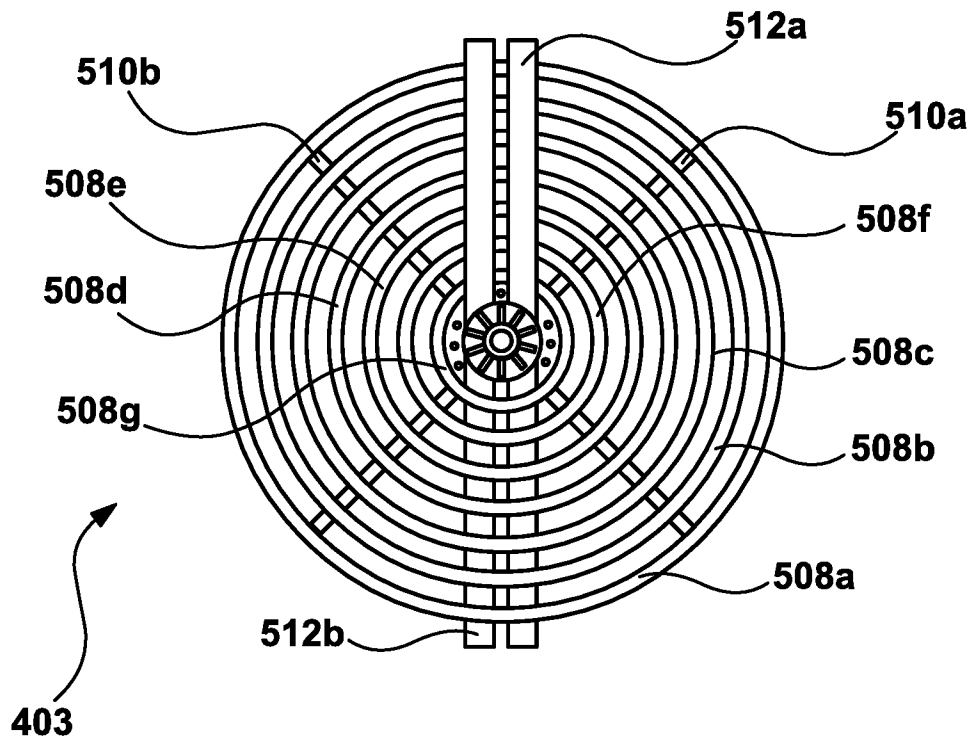

FIG. 5B

10/11

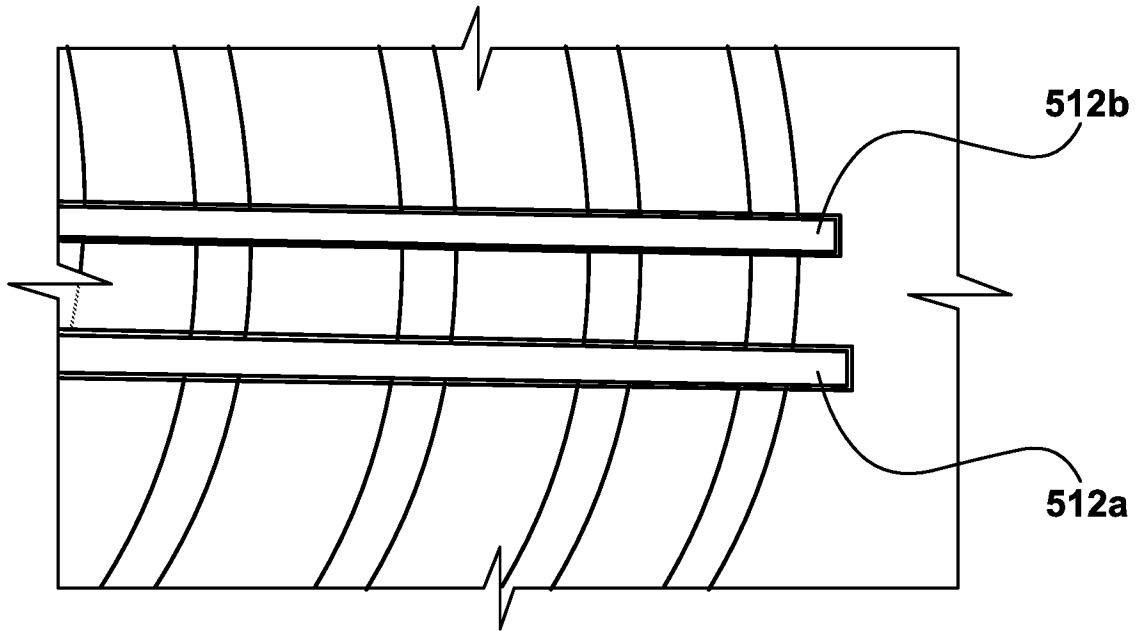

FIG.5C



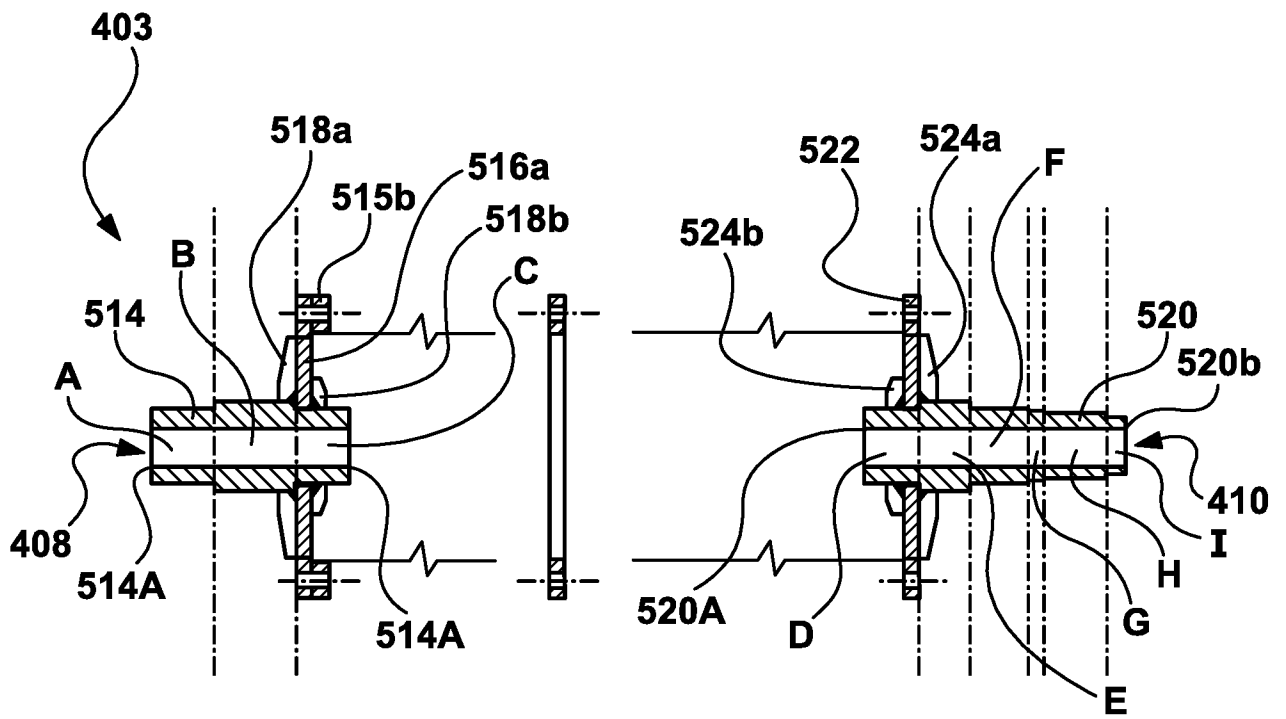

FIG. 5D

## INTERNATIONAL SEARCH REPORT

International application No.

PCT/US 16/51185

<b>A. CLASSIFICATION OF SUBJECT MATTER</b> IPC(8) - F26B 17/00, 17/18, 17/20 (2016.01) CPC - F26B 17/18, 17/20 According to International Patent Classification (IPC) or to both national classification and IPC		
<b>B. FIELDS SEARCHED</b> Minimum documentation searched (classification system followed by classification symbols) IPC(8) - F26B 17/00, 17/18, 17/20 (2016.01) CPC - F26B 17/18, 17/20 Documentation searched other than minimum documentation to the extent that such documents are included in the fields searched CPC - F26B 7/00, 17/00, 17/205, 19/00, 19/005, 25/02, 2200/02, 2200/04, 2200/12 Electronic data base consulted during the international search (name of data base and, where practicable, search terms used) Patbase; Google Patents; Google Scholar; Google Web; Espacenet; Search Terms --- See extra box ---		
<b>C. DOCUMENTS CONSIDERED TO BE RELEVANT</b>		
Category*	Citation of document, with indication, where appropriate, of the relevant passages	Relevant to claim No.
X --- Y	US 2006/0288884 A1 (Babbini) 28 December 2006 (28.12.2006), Figs. 1-3, para [0024]-[0032]	1-6, 11-13 and 17 --- 7-10, 14-16 and 18-20
Y	US 3,707,070 A (Chaplin) 26 December 1972 (26.12.1972), col. 9, ln. 1-5	7
Y	US 2006/0130353 A1 (Eloo) 22 June 2006 (22.06.2006), Figs. 2-9, para [0011], [0039]-[0040]	8-10, 14-16 and 18-20
A	WO 2004/080704 A1 (Atlas-Stord Denmark A/S) 23 September 2004 (23.09.2004), Figs. 1-3, pg. 5, ln. 4 - pg. 8, ln. 25	1-20
A	US 5,743,178 A (Babbini) 28 April 1998 (28.04.1998), Figs. 1-4, col. 2, ln. 17-63	1-20
A	US 4,565,124 A (Stautland et al.) 21 January 1986 (21.01.1986), Figs. 1-4, col. 3, ln. 7-62	1-20
<input type="checkbox"/> Further documents are listed in the continuation of Box C. <input type="checkbox"/>		
* Special categories of cited documents: "A" document defining the general state of the art which is not considered to be of particular relevance "E" earlier application or patent but published on or after the international filing date "L" document which may throw doubts on priority claim(s) or which is cited to establish the publication date of another citation or other special reason (as specified) "O" document referring to an oral disclosure, use, exhibition or other means "P" document published prior to the international filing date but later than the priority date claimed "T" later document published after the international filing date or priority date and not in conflict with the application but cited to understand the principle or theory underlying the invention "X" document of particular relevance; the claimed invention cannot be considered novel or cannot be considered to involve an inventive step when the document is taken alone "Y" document of particular relevance; the claimed invention cannot be considered to involve an inventive step when the document is combined with one or more other such documents, such combination being obvious to a person skilled in the art "&" document member of the same patent family		
Date of the actual completion of the international search		Date of mailing of the international search report
08 December 2016		13 JAN 2017
Name and mailing address of the ISA/US Mail Stop PCT, Attn: ISA/US, Commissioner for Patents P.O. Box 1450, Alexandria, Virginia 22313-1450 Facsimile No. 571-273-8300		Authorized officer: Lee W. Young PCT Helpdesk: 571-272-4300 PCT OSP: 571-272-7774

INTERNATIONAL SEARCH REPORT

International application No.

PCT/US 16/51185

Continuation of Search Terms: aluminum\*, aperture\*, auger\*, biomass\*, coax\*, concentric\*, cylind\*, dehydrat\*, dewater\*, drain\*, drive\*, driving\*, drum\*, dual\*, engine\*, frame\*, garbage\*, horizontal\*, link\*, liquid\*, manure\*, mesh\*, metal\*, pair\*, perforat\*, pitch\*, plates, progress\*, screen\*, screw\*, second\*, sieve\*, sludge\*, stainless\*, steel\*, strainer\*, support\*, twin, two, upright\*, vertical\*, waste\*, water\*, worm