

(19) World Intellectual Property Organization
International Bureau



(43) International Publication Date
29 June 2006 (29.06.2006)

PCT

(10) International Publication Number
WO 2006/069327 A2

(51) International Patent Classification:
A61N 1/378 (2006.01)

(74) Agents: HESLIN, James, M. et al.; TOWNSEND AND TOWNSEND AND CREW LLP, Two Embarcadero Center, 8th Floor, San Francisco, California 94111-3834 (US).

(21) International Application Number:
PCT/US2005/046826

(81) Designated States (unless otherwise indicated, for every kind of national protection available): AE, AG, AL, AM, AT, AU, AZ, BA, BB, BG, BR, BW, BY, BZ, CA, CH, CN, CO, CR, CU, CZ, DE, DK, DM, DZ, EC, EE, EG, ES, FI, GB, GD, GE, GH, GM, HR, HU, ID, IL, IN, IS, JP, KE, KG, KM, KN, KP, KR, KZ, LC, LK, LR, LS, LT, LU, LV, LY, MA, MD, MG, MK, MN, MW, MX, MC, NA, NG, NI, NO, NZ, OM, PG, PH, PL, PT, RO, RU, SC, SD, SE, SG, SK, SL, SM, SY, TJ, TM, TN, TR, TT, TZ, UA, UG, US, UZ, VC, VN, YU, ZA, ZM, ZW.

(22) International Filing Date:
21 December 2005 (21.12.2005)

(25) Filing Language: English

(26) Publication Language: English

(30) Priority Data:
60/639,056 21 December 2004 (21.12.2004) US
60/639,027 21 December 2004 (21.12.2004) US
60/689,606 9 June 2005 (09.06.2005) US

(84) Designated States (unless otherwise indicated, for every kind of regional protection available): ARIPO (BW, GH, GM, KE, LS, MW, MZ, NA, SD, SL, SZ, TZ, UG, ZM, ZW), Eurasian (AM, AZ, BY, KG, KZ, MD, RU, TJ, TM), European (AT, BE, BG, CH, CY, CZ, DE, DK, EE, ES, FI, FR, GB, GR, HU, IE, IS, IT, LT, LU, LV, MC, NL, PL, PT, RO, SE, SI, SK, TR), OAPI (BF, BJ, CF, CG, CI, CM, GA, GN, GQ, GW, ML, MR, NE, SN, TD, TG).

(71) Applicant (for all designated States except US): EBR SYSTEMS, INC. [US/US]; 686 West Maude Avenue, Suite 102, Sunnyvale, California 94085 (US).

(72) Inventors; and

(75) Inventors/Applicants (for US only): BRISKEN, Axel, F. [US/US]; 764 Boar Circle, Fremont, c 94539 (US). COWAN, Mark, W. [US/US]; 1766 Mandan Place, Fremont, California 94539 (US). ECHT, Debra, S. [US/US]; 525 Eleanor Drive, Woodside, California 94062 (US). RILEY, Richard, E. [US/US]; 795 Stone Lane, Palo Alto, California 94303 (US).

Declaration under Rule 4.17:

— as to applicant's entitlement to apply for and be granted a patent (Rule 4.17(ii))

Published:

— without international search report and to be republished upon receipt of that report

[Continued on next page]

(54) Title: IMPLANTABLE TRANSDUCER DEVICES

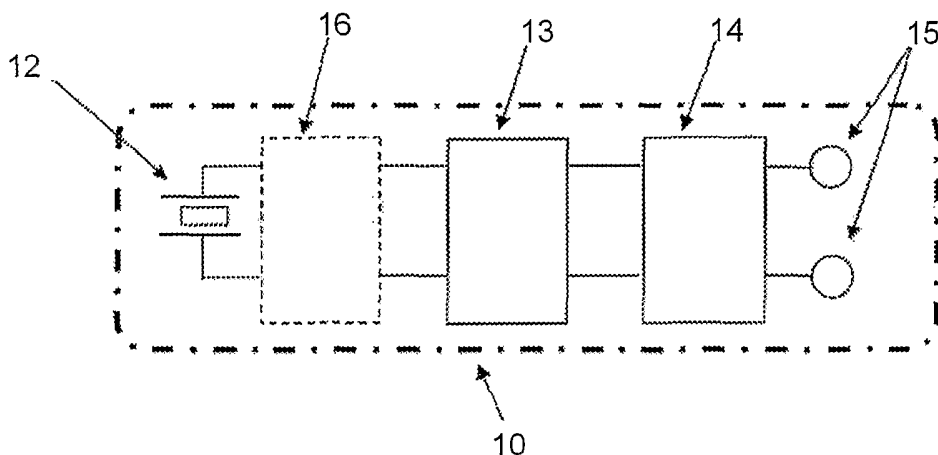

(57) Abstract: Receiver-stimulators comprise a nearly isotropic transducer assembly, demodulator circuitry, and at least two tissue contacting electrodes. Use of near isotropic transducers allows the devices to be implanted with less concern regarding the orientation relative to an acoustic energy source. Transducers or transducer elements having relatively small sizes, typically less than 1/2 the wavelength of the acoustic source, enhance isotropy. The use of single crystal piezoelectric materials enhance sensitivity.

WO 2006/069327 A2



For two-letter codes and other abbreviations, refer to the "Guidance Notes on Codes and Abbreviations" appearing at the beginning of each regular issue of the PCT Gazette.

IMPLANTABLE TRANSDUCER DEVICES

[0001] The subject matter of this application is related to that of the following commonly owned patent applications: 10/869,242 (Attorney Docket No. 021834-000310US); 10/869,776 (Attorney Docket No. 021834-000130US); and 10/869,705 (Attorney Docket No. 021834-000620US). The full disclosures of each of these prior filings are incorporated herein by reference but the benefit of the filing dates is not being claimed.

BACKGROUND OF THE INVENTION

10 [0002] 1. Field of the Invention. The stimulation of cardiac tissue using an acoustic transducer, referred to as a controller-transmitter, and one or more implanted receiver-stimulator devices has recently been proposed by the inventors herein in the patent applications referred to above. The controller-transmitter produces an acoustic signal which is received by the receiver-stimulator, and the receiver-stimulator in turn generates an electrical signal which is delivered to
15 cardiac or other tissue through coupled tissue electrodes. The controller-transmitter may be external, but will usually be implanted, requiring that the controller-transmitter have a reasonable size, similar to that of implantable pacemakers, and that the controller-transmitter be capable of operating from batteries for a lengthy period, typically three or more years. The relatively small size and relatively long operational period require that the receiver-stimulators efficiently utilize
20 the acoustic energy from the controller-transmitters.

[0003] For those reasons, it would be desirable to provide implantable transducer devices which are able to efficiently receive acoustic energy from implanted or external acoustic transmitters. It would be particularly desirable if the transducers could operate in an isotropic or nearly isotropic fashion where they could efficiently receive acoustic energy from an acoustic
25 transmitter regardless of the relative orientation between the transmitter and the implanted transducer. At least some of these objectives will be met by the inventions described hereinafter.

[0004] 2. Description of the Background Art. The following patents and patent publications describe various implantable transducers capable of converting applied acoustic energy into an electrical output: U.S. Patent Nos. 3,659,615; 3,735,756; 5,193, 539; 6,654,638; 6,628,989; and

6,764,446; U.S. Patent Application Publications 2002/0077673; 2004/0172083; and 2004/0204744; and published German application DE 4330680.

BRIEF SUMMARY OF THE INVENTION

5 [0005] Systems and methods are provided for delivering electrical energy to body tissues for a variety of purposes. The energy will typically be delivered in order to stimulate cardiac tissue, for example in cardiac pacing for bradycardia, for termination of tachyarrhythmia, for bi-ventricular resynchronization therapy for heart failure, or the like. The systems and methods of the present invention, however, could be used in a variety of other applications, including
10 applications for nerve stimulation, brain stimulation, voluntary muscle stimulation, gastric stimulation, bone growth stimulation, pain amelioration, and the like.

[0006] In a first aspect, the present invention provides an implantable receiver-stimulator device which is capable of receiving acoustic energy delivered from an acoustic source (physically separate from the receiver-stimulator device) and converting that acoustic energy to
15 an electrical signal. The receiver-stimulator of the present invention will usually be very sensitive and will usually be able to receive and convert low levels of acoustic energy to produce electrical signals which are able to stimulate myocardial tissue. Typically, with devices of the present invention with cross sectional areas on the order of 3 mm^2 , an acoustic wave having a pressure level in the range from 0.2 to 0.4 mega Pascals (an intensity level of 1.3 to 5.6 W/cm^2),
20 can be converted to electrical signals in the range from 1.0 to 2.0_Volts. Thus, the devices of the present invention will usually be very efficient and capable of converting a large portion of the received acoustic energy into electrical energy, typically with a conversion efficiency of at least 25%, often being at least 50%. In addition to such high sensitivity and efficiency, the implantable receiver-stimulators of the present invention are also capable of functioning at least
25 substantially isotropically. That is, the device sensitivity will be isotropic. By "isotropic," it is meant that the receiver-stimulator will have a transducer assembly capable of receiving acoustic energy in a manner which is substantially insensitive to the relative orientation of the device to the acoustic source. The electric signal produced by the receiver-stimulator device in response to incident acoustic energy will vary by no more than $\pm 6 \text{ dB}$ as the orientation of the device varies

relative to the acoustic source, often varying by no more than ± 3 dB, preferably varying by no more than ± 1 dB.

[0007] In a first specific embodiment, an implantable receiver-stimulator comprises a transducer assembly, typically being capable of isotropic operation as noted above, which receives acoustic energy from an acoustic source and which produces an electrical signal in response to the acoustic energy. The device further comprises demodulator circuitry which receives the electrical signal and which produces a biologically stimulating electrical output, e.g., suitable for cardiac pacing, nerve stimulation, brain stimulation, voluntary muscle stimulation, pain amelioration, or the like. The device will further include at least two tissue-contacting electrodes which are coupled to the demodulator circuitry to receive the stimulating electrical output and deliver said output to the tissue. Either or both of the electrodes may be mounted directly on the device, in some instances forming a portion of the device casing, or may alternatively be connected to the device by wires, cables, or the like, for placement.

[0008] The transducer assembly may comprise a cylindrical piezoelectric transducer having a pair of electrodes formed over opposed surfaces thereof. The incident acoustic energy will cause the piezoelectric transducer to vibrate and generate electrical charge which is collected by the electrodes and available for delivery to the demodulator circuitry. In a first exemplary embodiment, the piezoelectric transducer may be composed of a polycrystalline ceramic piezoelectric material. When the ceramic piezoelectric material is formed in the shape of a tube, the opposed electrodes may typically be formed over the outer and inner cylindrical surfaces of the transducer although electrodes over the opposing flat end surfaces may also be used.

[0009] In a preferred exemplary embodiment, however, the piezoelectric transducer will be composed of a single crystal material, typically being cut in the $\langle 001 \rangle$ orientation. A preferred single crystal material comprises PMN-xPT material, where x is in the range from 5% to 50% by weight. Other single crystal materials may be of the composition PZN-xPT, or Relaxor-PT materials. When the piezoelectric transducer is composed of a single crystal, the opposed electrodes are preferably formed over the opposed flat end surfaces of the cylinder, not the cylindrical surfaces. Alternatively, for alternate crystal planes, electrodes formed on cylindrical surfaces or cylindrical surfaces on sectioned and composite crystal assemblies, may be preferred.

[0010] In a still further embodiment of the implantable receiver-stimulator of the present invention, the transducer assembly comprises a plurality of individual transducer elements. The demodulator circuitry similarly comprises a plurality of individual demodulator circuits, and each of the transducer elements is attached to one of the individual demodulator circuits. The transducer elements themselves will typically have a maximum dimension which is approximately one-half wavelength of the expected acoustic transmission, but the cumulative lateral dimensions of the individual transducer elements will preferably be much greater than a single wavelength. On the output of the demodulator circuitry there will be provisions for summing the electrical signals from each of the individual demodulator circuits to produce the biologically stimulating electrical output. Electrical signals may be summed in parallel, in series, or in a series-parallel combination.

[0011] In a second aspect of the present invention, methods for delivering energy to an implanted receiver-stimulator comprise implanting a receiver-stimulator, typically formed as an assembly having a transducer or transducers, being substantially isotropic as described above in connection with the devices of the present invention. Acoustic energy is directed to the implanted receiver-stimulator assembly from an acoustic source, which may be implanted or located externally, and the transducers produce electrical signals which vary by no more than ± 6 dB as the orientation of the transducers vary relative to that of the acoustic source. The electrical signal is demodulated to produce a biologically stimulating electrical output, and the electrical output is delivered to tissue. The acoustic energy may be delivered to the receiver-stimulator from an external source, but will preferably be delivered from an implanted acoustic source. The electrical output flowing between stimulating electrodes which are in contact with tissue may possess specific characteristics of voltage, current, waveform, and the like. These electrical characteristics will be selected to stimulate the target cardiac tissue, nerve tissue, brain tissue, voluntary muscle tissue, bone tissue, or the like.

BRIEF DESCRIPTION OF THE DRAWINGS

[0012] Fig. 1 is a block diagram illustrating a receiver-stimulator constructed in accordance with the principles of the present invention.

[0013] Fig. 2 illustrates a first exemplary transducer design of a type useful in the receiver-stimulators of the present invention.

[0014] Fig. 3 illustrates a second exemplary transducer design of the type useful in the receiver-stimulators of the present invention, particularly being useful with single crystal
5 transducers.

[0015] Fig. 4 is a schematic illustration of the elevation angle definition for beam profile measurement.

[0016] Figs. 5 and 6 illustrate the elevation angle beam profiles for a single crystal transducer and a polycrystalline ceramic transducer.

10 [0017] Figs. 7-9 are impedance plots for different transducer materials.

[0018] Fig. 10 is an embodiment of transducer assemblies employing multiple transducer elements

[0019] Figs. 11-12 are two embodiments of transducer assemblies employing multiple transducer elements in accordance with the principles of the present invention.

15 [0020] Fig. 13 illustrates an exemplary construction for a transducer assembly having multiple individual transducer elements.

[0021] Figs. 14A-14I show exemplary waveform summation plots produced by the multiple element transducer assemblies of the present invention.

[0022] Figures 15A-15d illustrate various single crystal orientations and respective sensitivity
20 profiles of transducer in the present invention.

DETAILED DESCRIPTION OF THE INVENTION

[0023] As illustrated in Fig. 1, an exemplary receiver-stimulator 10 constructed in accordance with the principles of the present invention comprises a transducer assembly 12, demodulator
25 circuitry including a rectifier circuit 13 and a filter circuit 14, and tissue-contacting electrodes 15. Optionally, impedance matching circuit 16 may be provided to match the output of the transducer assembly with the electrical impedance presented by the rectifier/filter circuits and

the tissue contacted by the electrodes. The present invention provides certain specific designs for the transducer assembly 12 and for assemblies of transducers which in turn provide a highly isotropic receiver-stimulator operation such that the output of the transducer or transducers is highly independent of the orientation of the transducer or transducers relative to an acoustic source.

5 [0024] A first nearly isotropic transducer assembly 29 useful in the present invention is illustrated in Fig. 2. The transducer assembly 29 generally comprises a cylindrical polycrystalline piezoelectric tube 20 with an outer cylindrical electrode 21 and an inner cylindrical electrode 22. Typically the ceramic may be mounted on a thin walled tube 23 of polyamide or other suitable material, with or without an epoxy bond between the inner wall of the ceramic and the outer wall of the tube. Both flat faces of the ceramic may have an acoustic absorber 24 between the ceramic and before the start of the structural body 25. All internal surfaces are typically bonded with low viscosity epoxy. The outer surface of the assembly is typically coated with a low viscosity epoxy under a thin walled shrink tube 26. Prior to assembly, electrical leads 28 are soldered to the inner and outer electrodes, and passed through the hollow inner volume 27 of the inner tube. Optionally, other circuit components as shown in Fig. 1 may also be positioned in the hollow inner volume 27. Devices of this type can provide near isotropic sensitivity, typically on the order of 6-12 dB down, in the elevation angle along the cylindrical axis as compared to the sensitivity normal to the cylindrical axis, where the elevation angle with respect to the cylindrical axis is depicted in Figure 4.

15 [0025] While the transducer assembly 29 of Fig. 2 provides a high degree of isotropic sensitivity, it would be desirable to provide transducer assemblies which operate even more isotropically. Referring to Fig. 3, the use of single crystal piezoelectric materials can provide further enhancement. A single crystal device 39 would be fabricated in a similar manner to the polycrystalline ceramic device, with the exception that the electrodes 31 and 32 of the single crystal piezoelectric would be on the flat faces of the cylinder 30 which is a single crystal material cut in the $\langle 001 \rangle$ orientation, and wired accordingly with leads 28. Standard crystallographic terms are used here to define crystal axes. The Miller indices (hkl) define the orientation of a plane with respect to the crystal axes. A separate axis perpendicular to the plane

(hkl) is defined by the term $\langle hkl \rangle$. Therefore, a (001) plane would be parallel to the xy crystal plane and perpendicular to the crystal z axis. The $\langle 001 \rangle$ axis is thus parallel to the crystal z axis.

[0026] Devices of the type depicted in Figure 3 have been fabricated with single crystal component sizes virtually identical to the ceramic components. As detailed below, there are similarities in performance such as beam profiles. Most significantly, the single crystals have superior isotropic sensitivity, especially at a low frequency resonance which is not achieved by the higher frequency resonance of the ceramic piezoelectrics.

[0027] Figures 5 and 6 depict measured and model data for beam profiles at 340 kHz and 550 kHz of representative devices. The single crystal device profiles are depicted in Figure 5 and the ceramic device profiles are depicted Figure 6. For these profiles, the beam angle is defined as the elevation angle as depicted in Figure 4. An elevation angle of 0 degrees corresponds to an incident beam normal to the cylindrical axis of the device, 90 degrees parallel to the cylindrical axis, and 180 degrees normal to the cylindrical axis, but in the opposite direction from 0 degrees. Due to symmetry, in the absence of gross fabrication defects, these devices will usually have sensitivity fluctuations of less than 1 dB in azimuth, around the cylindrical axis of the piezoelectric tube. With respect to the elevation angle, a perfectly isotropic device would have a flat response from 0 to 90 to 180 degrees. Further, at lower frequencies both devices exhibit less anisotropy than predicted by diffraction theory. However, the variation in anisotropy remains inconsistent with a simple diffraction model based on device size and frequency. Acoustic coupling through structural components of the test articles are assumed responsible for this discrepancy.

[0028] With respect to sensitivity, Table 1 below summarizes device sensitivity in a plane normal to the cylindrical axes of the devices. The devices were exposed to long bursts of ultrasound, in the general range of 340 kHz and 600 kHz. With no electrical load on the devices, the generated peak-to-peak voltage was measured by a high input impedance digital oscilloscope, with the results tabulated below with respect to the ultrasound field strength in MI (Mechanical Index, defined as rarefactional pressure in mega Pascals divided by the square root of the frequency in mega Hertz). Subsequently, in each test, the devices were electrically loaded with a 500 ohm resistor, with the results next tabulated below with respect to field strength. The electrical impedance of 500 ohms was used and was representative of the impedance between

electrodes in contact with various human tissue types. And lastly, the devices were near optimally impedance matched with a transformer, connected to a full wave rectifier with a 0.1 micro Farad capacitor, and loaded with 500 ohms. The peak amplitude of the resulting DC (direct current) voltage envelope with respect to the field strength is reported below.

5

TABLE 1

Device s/n	Type	Frequency (kHz)	Unloaded Vac/MI (Vpp)	500 Ω Load Vac/MI (Vpp)	Det/Fil Vdc/MI (Vop)
2199	Ceramic	550	8.90	5.40	2.05
2199	Ceramic	340	4.28	2.73	0.65
2216A	Crystal	570	30.4	8.53	4.06
2216A	Crystal	340	102.0	16.8	8.10
2195	Ceramic	600	17.0	10.9	2.76
2195	Ceramic	340	3.70	1.97	0.41

[0029] In the above Table, device 2199 was a PZT-5H ceramic tube, 0.070 inches long, 0.070 inches in outside diameter, and 0.045 inches on inner diameter. The tube was polarized with electrodes on the inner and outer cylindrical surface. Device 2216A was a PMN-32%PT single crystal tube, with the same dimensions as device 2199. However, the device was cut from a plate perpendicular to the <001> crystal orientation axis. The electrodes were on the flat faces with polarization between the electrodes. Device 2195 was a ceramic tube in all aspects the same as device 2199, with the exception of a 0.040 inch length.

[0030] In an open circuit mode, the single crystal devices are vastly superior to the ceramic devices. However, this represents an unrealistic situation in that sufficient current needs to be derived from the devices to stimulate tissue. While the single crystal materials still enjoy a substantial advantage when loaded with a representative tissue impedance, the performance gap has lessened. And lastly, when driving impedance matching, rectifier, filter, and representative tissue loaded circuits, there was still a good performance gap, but with slight variations.

[0031] The primary reason for the excellent performance of the single crystal material was the low frequency constant which results in a resonance at approximately 340 kHz, as seen in Figure 7. For the same sized piece of material, there exists a small resonance in the ceramic at approximately 600 kHz as seen in Figure 8, thus slightly enhanced relative to the performance of

the ceramic at 550 kHz. A much stronger resonance exists at approximately 900 kHz. This resonance unfortunately cannot be used as the wavelength thus becomes smaller than the device, predisposing the device to yet greater elevation angle anisotropy. Interestingly, in device 2195, with a length half that of 2199, the length mode resonance was pulled down to approximately
5 600 kHz as seen in Figure 9, and thus the slightly better performance of the shorter device at 600 kHz was observed.

[0032] In comparing the performance of the single crystal at its resonance of 340 kHz with the ceramics at their lowest frequency resonances at 550 to 600 kHz, the single crystal device was still on average more than 10 dB more sensitive, fully loaded, than the ceramic devices.
10 Comparing the single crystal at its off resonance frequency with the ceramics at their off resonance frequencies, the single crystal device was more than 17 dB more sensitive. The single crystal material was thus seen to offer significant improvement over the ceramic material as a source of electrical energy in an acoustic field for the tissue stimulator.

[0033] The present invention has detailed the implementation of single crystal piezoelectric
15 tubes cut in the $\langle 001 \rangle$ orientation for use in implantable receiver-stimulator devices, where the sensitivity normal to the crystal axis is circumferentially uniform in all directions, as depicted in Figure 15A by the dashed line around the tube cross sectional view. Multiple different orientation planes of single crystals also have potential utility. One such possible configuration would utilize the properties of the single crystal tube cut in the $\langle 011 \rangle$ plane, where the lateral
20 sensitivity has a crossed dipole shape, with an amplitude in the $\langle 100 \rangle$ direction higher by a factor of approximately two than the single crystals discussed above, but with an orthogonal sensitivity being of reverse polarity and less amplitude, as depicted in Figure 15B. If this crystal were to be directly implemented, the reverse polarity sensitivity would detract from the stronger orthogonal dipole lobes, and yield a device with perhaps less sensitivity than the devices as
25 described above. However, if quadrants of the single crystal comprising the higher sensitivity dipole lobes (as highlighted by the arcs in Figure 15B) were to be cut out, and four quadrants of this high sensitivity material reassembled as depicted in Figure 15C, the net effect would be a single crystal tube with high sensitivity in all four quadrants, and net greatly increased sensitivity. Since the original tubular shape has been maintained, all mechanical resonances
30 within the device remain the same. Alternatively, the cut sections with favorable crystal

orientation may be smaller, 60 degrees of arc instead of 90 degrees of arc, and reassembled, as depicted in Figure 15D, for yet higher sensitivity. Since the anticipated operating wavelength is larger by approximately a factor of two than the physical size of the reassembled device, the sensitivity will be averaged over the surface of the device.

5 [0034] A further embodiment of the implantable receiver-stimulators of the present invention utilizes a transducer assembly which includes multiple transducer elements at least some of which have a size (equal to or less than one-half wavelength) selected to enhance the isotropic nature of the individual elements. Generally if the piezoelectric transducer size exceeds one half wavelength of the acoustic signal, directional variations in sensitivity will begin to dominate
10 performance, whereas with device sizes less than one half wavelength, device sensitivity approaches isotropy, being almost uniform in all directions. Hydrophones, which are devices to sample acoustic fields, typically have upper operational limits corresponding to a sensor size of one half wavelength. Larger sizes would be preferred for hydrophone elements as the output is directly proportional to the cross sectional area of the device. Thus, for the receiver-stimulator,
15 multiple elements are added specifically to increase the cross sectional area of the device to increase sensitivity. The implantable devices must have near isotropic responses, as the orientation of a device with respect to the acoustic excitation field may not coincide with the orientation of the device as it is implanted in the tissue which requires stimulation.

[0035] As depicted in Figure 10, a transducer assembly featuring multiple elements 112a,
20 112b, 112c, 112n and output leads 113a, 114a, 113b, 114b, 113n, 114n are wired in parallel to a single pair of connecting leads 116a and 116b to a single detector/filter circuit 118, which passes the combined signal to tissue contact stimulation electrodes 120a and 120b, via leads 119a and 119b. This technique, however, while offering more ceramic volume to achieve a greater power output, is subject to the constructive or destructive interference of signals into the detector/filter
25 118 from each of the individual elements due to the different arrival times of the signals from each element. It would be difficult to position the set of individual elements in such a manner as to assure only constructive interference of the individual signals. This configuration offers high sensitivity only when the phase of the incident acoustic signal is identical at each element and thus is not a preferred embodiment of the present invention.

[0036] In order to overcome this deficit and yet to use multiple elements for greater output power, and to reduce or eliminate constructive and destructive interference between the elements, a separate detector/filter for each element is provided. The combination of a single transducer element and a single detector/filter may be referred to as a channel. As depicted in Figure 11, individual elements 122a, 122b, 122c, 122n drive their own respective detector/filters 125a, 125b, 125c, 125n via their leads 123a, 124a, 123b, 124b, 123n, 124n. The output leads 126a, 127a, 126b, 127b, 126n, 127n of the detector/filters are wired in parallel via leads 129a and 129b and are thence connected directly to the stimulation electrodes 130a and 130b. In this manner, the current delivery of the device (assuming the elements are all the same and receive the same acoustic signal) is multiplied by the number n of individual channels within the device.

[0037] Alternatively, as depicted in Figure 12, the outputs of the individual detector/filters can be wired in series, with output leads 139a and 139b passing directly to the tissue stimulation electrodes 140a and 140b, while intermediate leads such as 137a and 136b between channels are connected. In this manner, the voltage delivery of the device (assuming the elements are all the same and receive the same acoustic signal) is multiplied by the number n of individual channels within the device.

[0038] Further, it is also possible to combine series and parallel connections on the outputs of the individual channels to achieve at least partially specific impedance matching between the individual piezoelectric elements and a target tissue mass.

[0039] To demonstrate this concept, a multi-element section 142 was fabricated as depicted in Figure 13, comprising four individual cylindrical tube transducer elements 141a to 141d, which were epoxy bonded to the inside wall of thin walled polyimide tubing 143. Transducer electrode lead wires 144a to 144h were fed to one end of the tubing. There was no fluid path to the hollow air-filled inside of the polyimide tube. The individual transducer elements had an outer diameter of approximately 0.6 wavelengths and a length of approximately 0.8 wavelengths, with a gap between elements of approximately 0.6 wavelengths at 500 kHz. In this prototype implementation, the detector/filter circuits were voltage doublers, as described in a co-pending application.

[0040] In Figures 14A and 14B the traces from top to bottom follow the top to bottom order of the index to the right of the chart. Figure 14A depicts the output voltage from each of the four

elements (top four traces) when the device was oriented askew with respect to an ultrasound beam. Because of the random phase variations among the elements, a series connection (RF SUM) resulted in a net signal weaker than that from any element on its own. Indeed, if the outputs of the individual elements were to be mathematically summed (MATH SUM), the waveform is virtually identical to that of the RF SUM. Even though each individual element may have had a near isotropic response, destructive interference of the series-connected individual element signals has given a diminished output. The slight variations in the amplitudes of the four elements is due to slight fabrication variations and possible interaction of the acoustic beam between the elements.

5
10 [0041] Figure 14B depicts a more ideal case, where the four elements are aligned virtually perpendicular to the ultrasonic beam. Since the size of the individual elements was slightly greater than the nominal half wavelength rule recited above, there is a slightly greater output of the individual element (top four traces) in this case, than in the previous "random alignment" angled case. In the same manner as above, the RF SUM represents the hardware wired combination of devices compared to the mathematical combination, MATH SUM. Note however that the RF SUM is slightly lower in amplitude than the MATH SUM. During the measurements, the individual elements were connected to individual open ended detector/filter circuits which presented a different electrical load as when the elements were wired in series and connected to a single open ended detector/filter circuit. Note further that in stark contrast to
15
20 Figure 14A, the phases of channel 1 to channel 4 are precisely aligned.

[0042] When looking at the output of the detector/filter circuit under a no load condition, the output voltage falls off very slowly as compared to the voltage rise due to the input signal from the transducer element. This is seen in the lower four traces of Figure 14C for the four channels (transducer element and detector/filter), where from approximately -5 microseconds to 100
25
30 microseconds the individual transducer elements are exposed to an ultrasonic field. In this case, and for all measurements of the remaining figures, the orientation of the four transducers with respect to the acoustic beam is skewed, causing random phases for the output of the individual transducer elements, as was the case for Figure 14A. In Figure 14C and 14D the top two traces represent the hardware summation of the DC output of the detector/filters, and the mathematical sum of the individual outputs. Note that the actual hardwired summation is virtually identical to

the mathematical sum of the individual channels. This is in stark contrast to the hardwired case of Figure 14A, where hardwired summation was performed on the output of the individual transducer elements with a single detector/filter.

[0043] Figure 14D represents the same conditions as Figure 14C, except the outputs of the individual channels, comprising the individual transducer elements and their respective
5 detector/filter circuits, were loaded with 1000 ohms, and the hardwired post detector summation was loaded with 4000 ohms. With 4000 ohms on the summed output, the current delivery from each channel was the same as in the unsummed state. Indeed, Figure 14E represents the same scenario wherein the hardwired output is loaded with 1000 ohms, which placed a factor of four
10 higher current demand on each of the four channels, and which consequently resulted in a significantly lower amplitude DC SUM since the individual transducer elements were unable to meet the demand. Further, the waveform of the summed output has become markedly flattened, clearly demonstrating the current threshold of the elements. Note also that in this case of resistive loading on the individual channels and on the summed outputs, while the rise time of
15 the detector/filter circuit is the same as before, the fall time is reduced, due to the drain of charge off the filter capacitors.

[0044] Figures 14G and 14F represent the same conditions as Figures 14C and 14D, with the exception that the channels were wired in parallel at the channel outputs. In both the no load case (Figure 14G) and in the resistively loaded case (Figure 14F), the same minor variation in
20 outputs from the different channels were observed. However, the hardwiring in parallel has created an average voltage, DC SUM, as corroborated by the mathematical average, MATH AVE, of the four traces. In the electrical loading case, 1000 ohms was applied to outputs in the individual detector/filter circuits, and 250 ohms was applied to the hardwired parallel sum. The reduction in resistance had the effect of keeping the voltage constant. The combined device
25 achieved a four times greater current delivery capability.

[0045] Lastly, in Figures 14H and 14I, the outputs of the detector/filter circuits were hardwired together, from one to four elements at a time, either in series or parallel, respectively. In Figure 14H, adding elements simply raised the output voltage in direct relation to the number of channels. In Figure 14I, the output voltage remained generally constant with the addition of

channels, but the current delivery capability increased according to the number of channels (no current graphic shown).

[0046] It has thus been demonstrated experimentally that summation in the RF domain (transducer element output) will result in constructive and destructive interference, dependent on the phase relationship between the elements. Alternatively, by providing summation after detection and filtering, a phase independent environment is established, with only constructive interference.

[0047] The detector circuits discussed for this application might include half wave rectifiers, full wave rectifiers, voltage doublers, charge-pump devices, and the like. Filters may include series inductors, parallel capacitors, combinations of the same, and the like. Impedance matching may be accomplished through transformer devices, active or passive circuit components, or may be incorporated into the design of the detector/filter circuits. Further details on the detector/filter circuits are provided in co-pending application.

[0048] With the requirement for isotropic transducers in the receiver-stimulator, transducer size (in all lateral dimensions) should not exceed approximately 0.5 wavelengths, subject only to the amount of variation tolerated in signal strength at various elevation angles. Given a velocity of sound in normal tissue of approximately 1.5 millimeters per microseconds, at 1 MHz device sizes shall not exceed approximately 0.75 millimeters, at 0.5 MHz 1.5 millimeters, and at 250 kHz 3.0 millimeters.

[0049] Transducers in the receiver-stimulator can be positioned and located in any orientation, with respect to the axis of the transmitted acoustic beam. Transducers can be mounted in a linear manner as depicted in Figure 13, or they can be mounted in a star pattern, a circular pattern, or a cross pattern, to recite just a few options. Further, the angular orientation of any transducer within the receiver-stimulator can be random. Anatomical conditions can be allowed to dictate the orientation of the implantable device.

[0050] While the above is a complete description of the preferred embodiments of the invention, various alternatives, modifications, and equivalents may be used. Therefore, the above description should not be taken as limiting the scope of the invention which is defined by the appended claims.

WHAT IS CLAIMED IS:

- 1 1. An implantable receiver-stimulator device comprising:
2 an isotropic transducer assembly which receives acoustic energy from an acoustic
3 source and which produces an electrical signal in response to the acoustic energy;
4 demodulator circuitry which receives the electrical signal and which produces a
5 biologically stimulating electrical output; and
6 at least two tissue contacting electrodes which receive the stimulating electrical
7 output and deliver said output to tissue.
- 1 2. An implantable receiver-stimulator as in claim 1, wherein the electric
2 signal produced by the transducer assembly in response to the acoustic energy varies by no more
3 than ± 6 dB as the orientation relative to an acoustic source varies.
- 1 3. An implantable receiver-stimulator as in claim 1, wherein the electric
2 signal produced by the transducer assembly in response to the acoustic energy varies by no more
3 than ± 3 dB as the orientation relative to an acoustic source varies.
- 1 4. A device as in claim 1, wherein the transducer assembly comprises a
2 piezoelectric transducer material.
- 1 5. A device as in claim 4, wherein piezoelectric transducer material is
2 composed of a polycrystalline ceramic piezoelectric material or is composed of a single crystal
3 piezoelectric material.
- 1 6. A device as in claim 4, wherein the transducer assembly comprises
2 a cylindrical piezoelectric transducer having a pair of electrodes formed over opposed surfaces
3 thereof.
- 4 7. A device as in claim 6, wherein the opposed electrodes are formed over
5 outer and inner cylindrical surfaces.
- 1 8. A device as in claim 6, wherein the piezoelectric transducer composed of a
2 single crystal piezoelectric material is cut in the $\langle 001 \rangle$ or $\langle 011 \rangle$ orientation.

1 9. A device as in claim 8, wherein the opposed electrodes are formed over
2 the flat end surfaces of the cylinder.

1 10. A device as in claim 4, wherein the transducer assembly comprises a
2 transducer composed of a single crystal cut in the <001> or <011> orientation.

1 11. A device as in claim 1, wherein the transducer assembly comprises a
2 transducer composed of a single crystal material of the PMN-xPT family, where x is in the range
3 from 5% to 50%.

1 12. A device as in claim 1, wherein the transducer assembly comprises a
2 transducer composed of a single crystal material of the PZN-xPT family, where x is in the range
3 from 5% to 50%.

1 13. A device as in claim 1, wherein the transducer assembly comprises a
2 transducer composed of a single crystal material of the Relaxor-PT family.

1 14. A device as in claim 5, wherein the acoustic source transmits the acoustic
2 energy at a frequency selected to match the lower frequency resonance of the piezoelectric
3 transducer material composed of the single crystal piezoelectric material.

1 15. A device as in claim 1, wherein the transducer assembly comprises a
2 plurality of individual transducer elements and wherein the demodulator circuitry comprises a
3 plurality of individual demodulator circuits, with the electrical signal from each transducer
4 element going to a demodulator circuit which produces an output, further comprising summing
5 circuitry which sums all of the electrical signals from all of the demodulator circuits to produce
6 the biologically stimulating electrical output.

1 16. A device as in claim 15, wherein the electrical signals are summed in
2 parallel.

1 17. A device as in claim 15, wherein the electrical signals are summed in
2 series.

1 18. A device as in claim 15, wherein the electrical signals are summed in a
2 series-parallel combination.

1 19. A device as in claim 15, wherein the transducer elements each have a size
2 less than one-half the wavelength of an acoustic source while collectively having a size greater
3 than one wavelength in any lateral dimension.

1 20. A device as in claim 1, further comprising a shell having a wall
2 surrounding an interior volume, wherein the transducer assembly and demodulator circuitry are
3 within the interior volume and wherein at least a portion of the wall is acoustically transmissive.

1 21. A device as in claim 20, wherein the entire shell is acoustically
2 transmissive.

1 22. A device as in claim 21, wherein the shell is cylindrical.

1 23. A device as in claim 22, wherein the shell has a diameter less than 5.0mm
2 and a length less than 20.0mm more preferably a diameter less than 3.0mm and a length less than
3 10.0mm.

1 24. A method for delivering energy to an implanted receiver-stimulator, said
2 method comprising:

3 implanting a receiver-stimulator having a transducer assembly;

4 directing acoustic energy to the implanted receiver-stimulator assembly from an
5 acoustic source, wherein the transducer produces an electrical signal which varies by no more
6 than ± 6 dB as the orientation of the transducer relative to the source varies;

7 demodulating the electrical signal to produce a biologically stimulating electrical
8 output; and

9 delivering the electrical output to tissue.

1 25. A method as in claim 24, wherein the transducer assembly is adapted to
2 receive acoustic energy in a substantially isotropic manner.

1 26. A method as in claim 24, wherein the acoustic energy is directed to the
2 receiver-stimulator from an external acoustic source.

1 27. A method as in claim 24, wherein the acoustic energy is directed to the
2 receiver-stimulator from an implanted acoustic source.

1 28. A method as in claim 24, wherein the electrical output comprises a cardiac
2 pacing waveform.

1

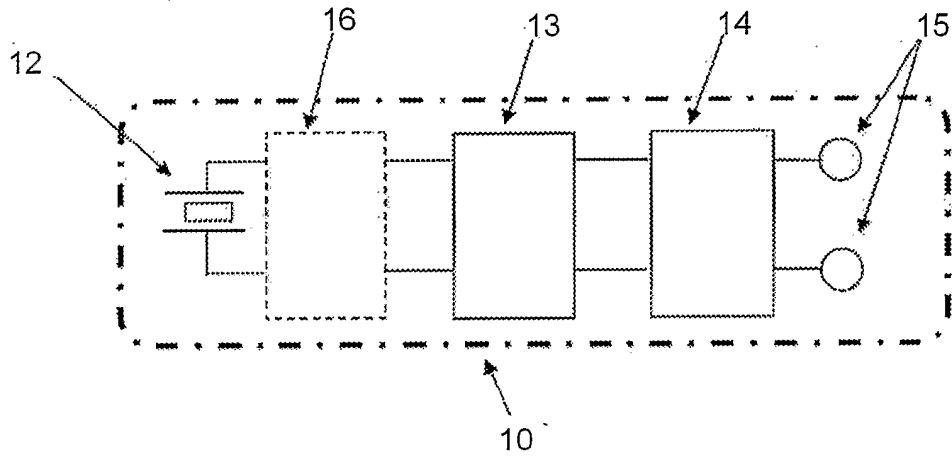

FIG. 1

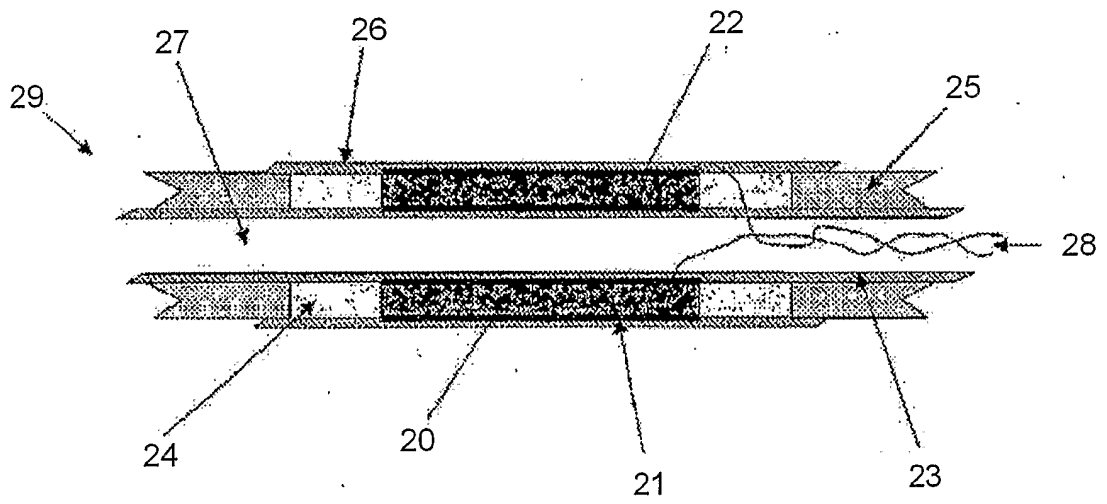

FIG. 2

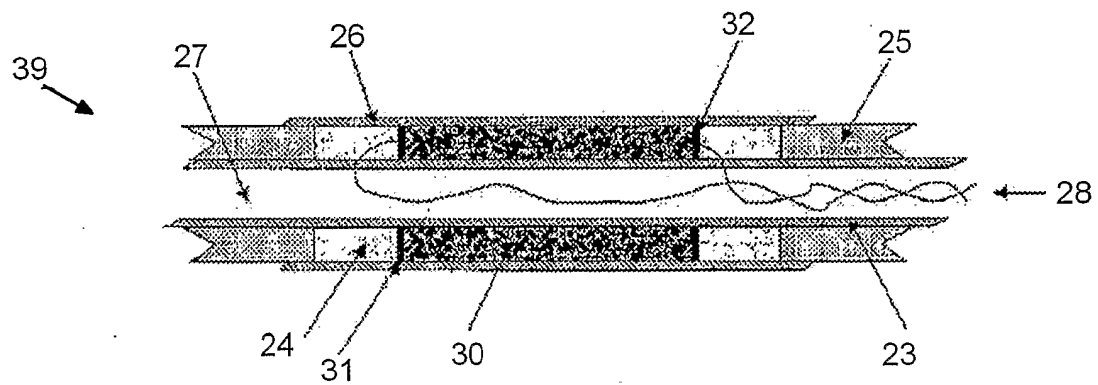

FIG. 3

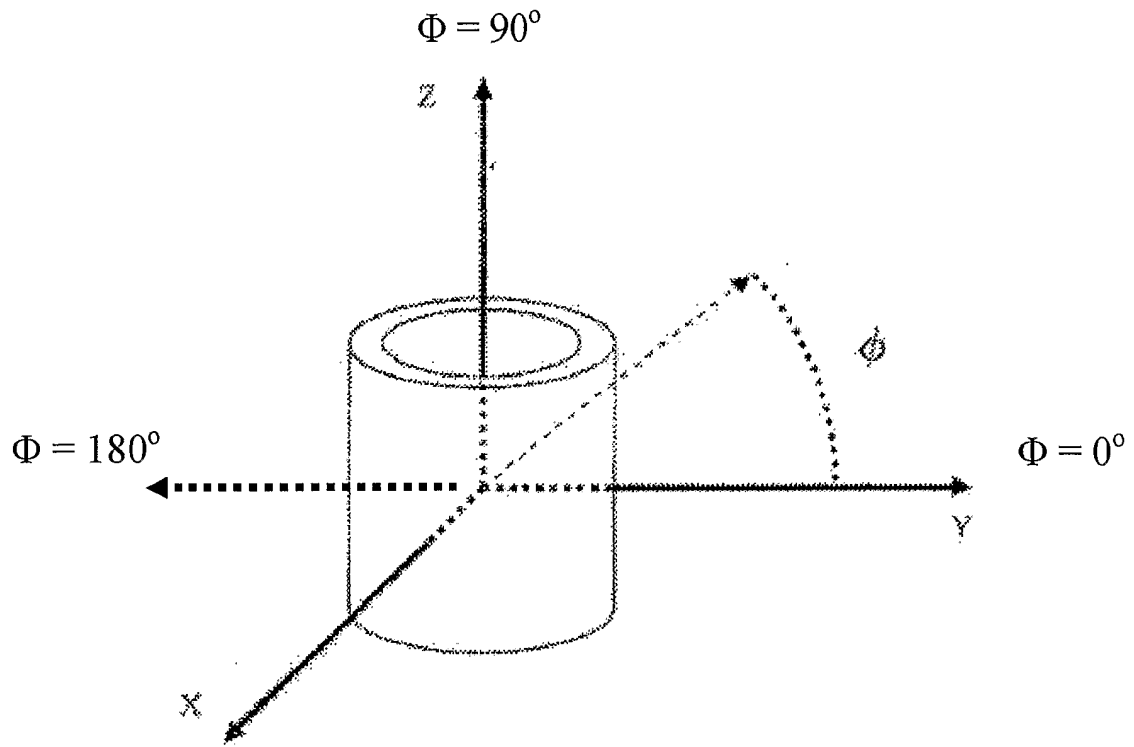

FIG. 4

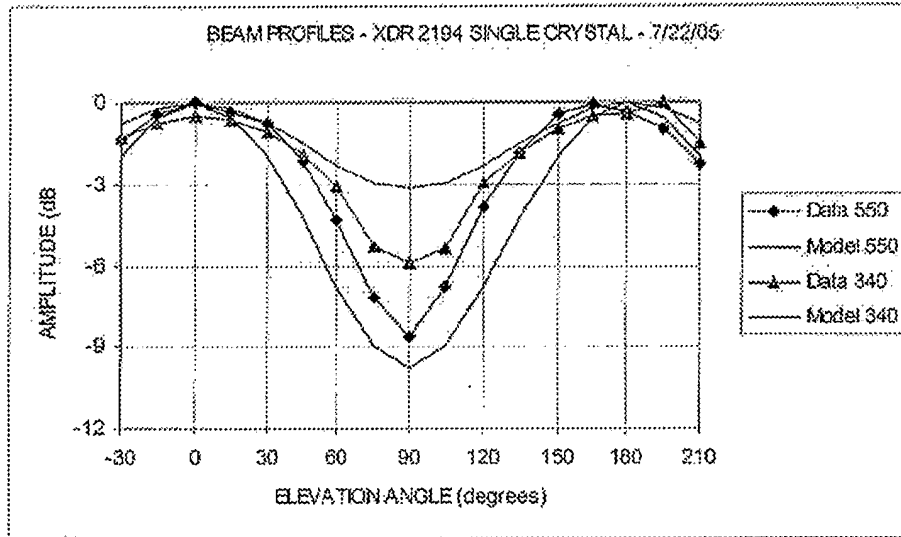

FIG. 5

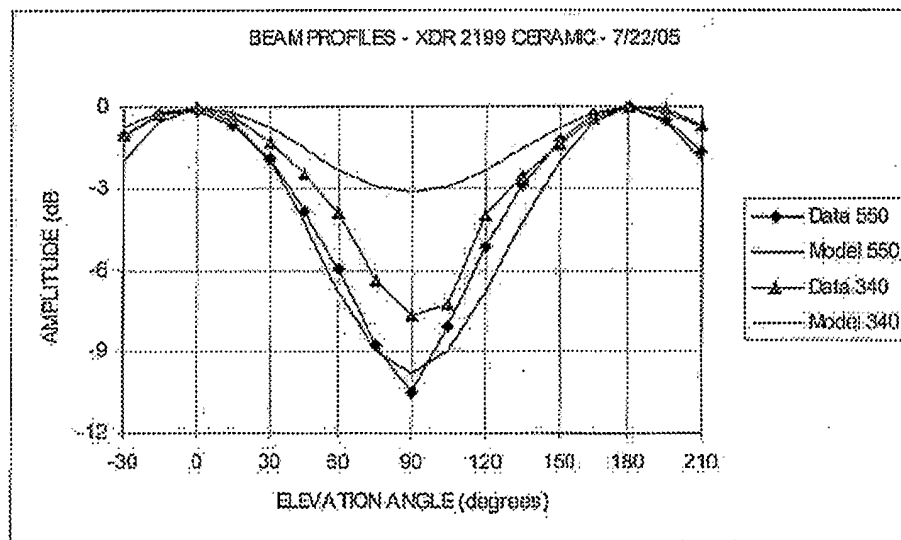

FIG. 6

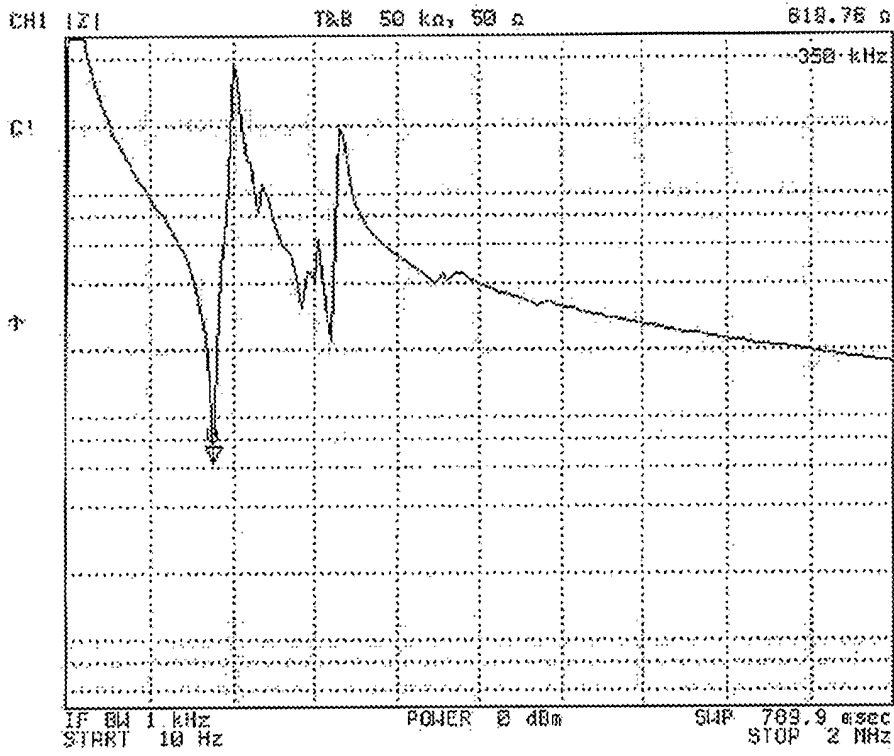

FIG. 7

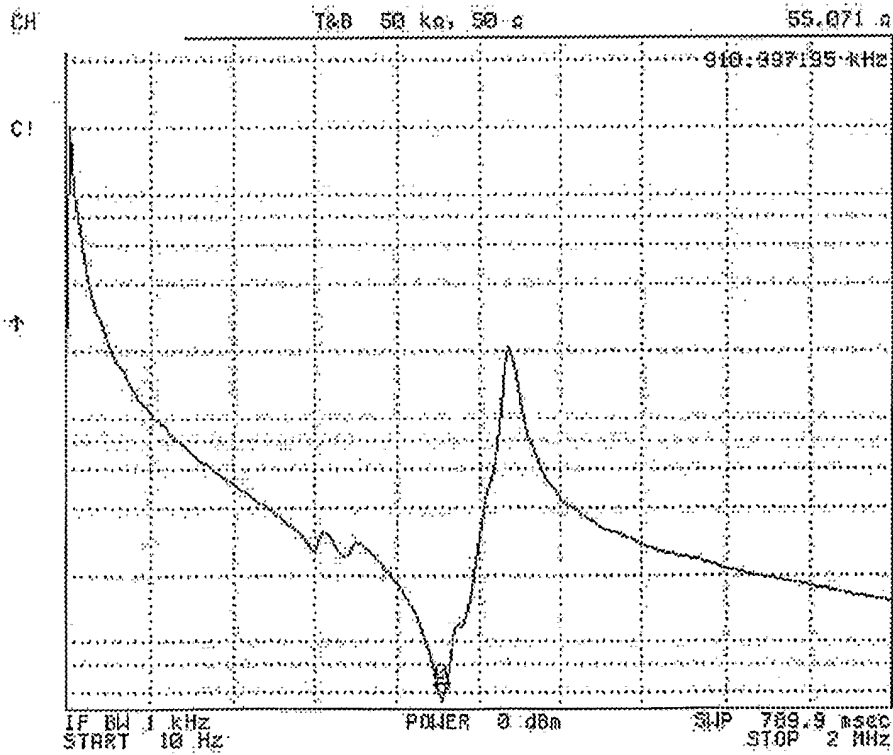

FIG. 8

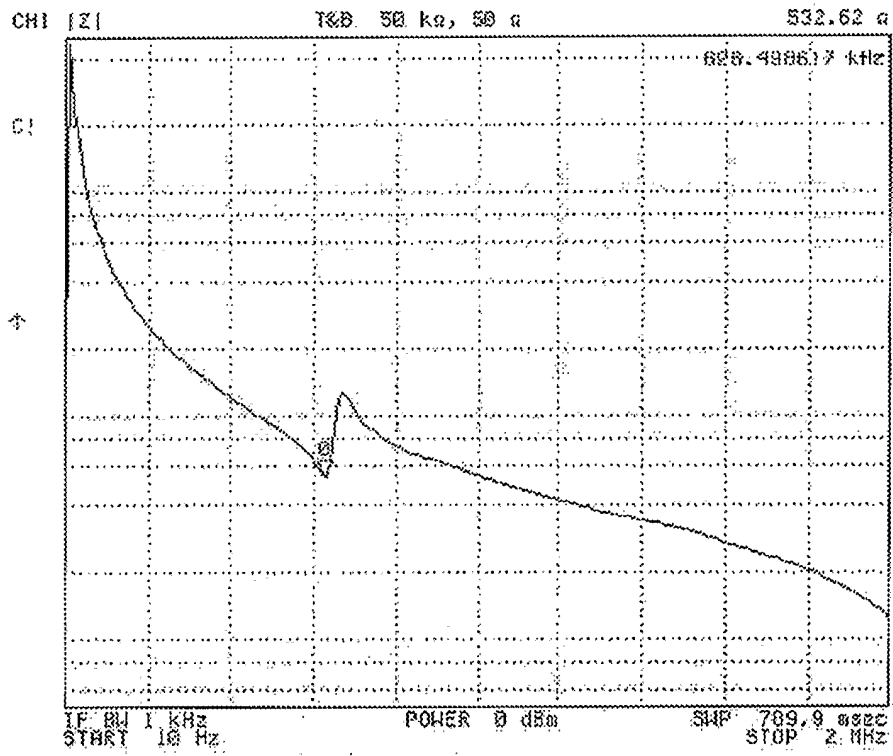

FIG. 9

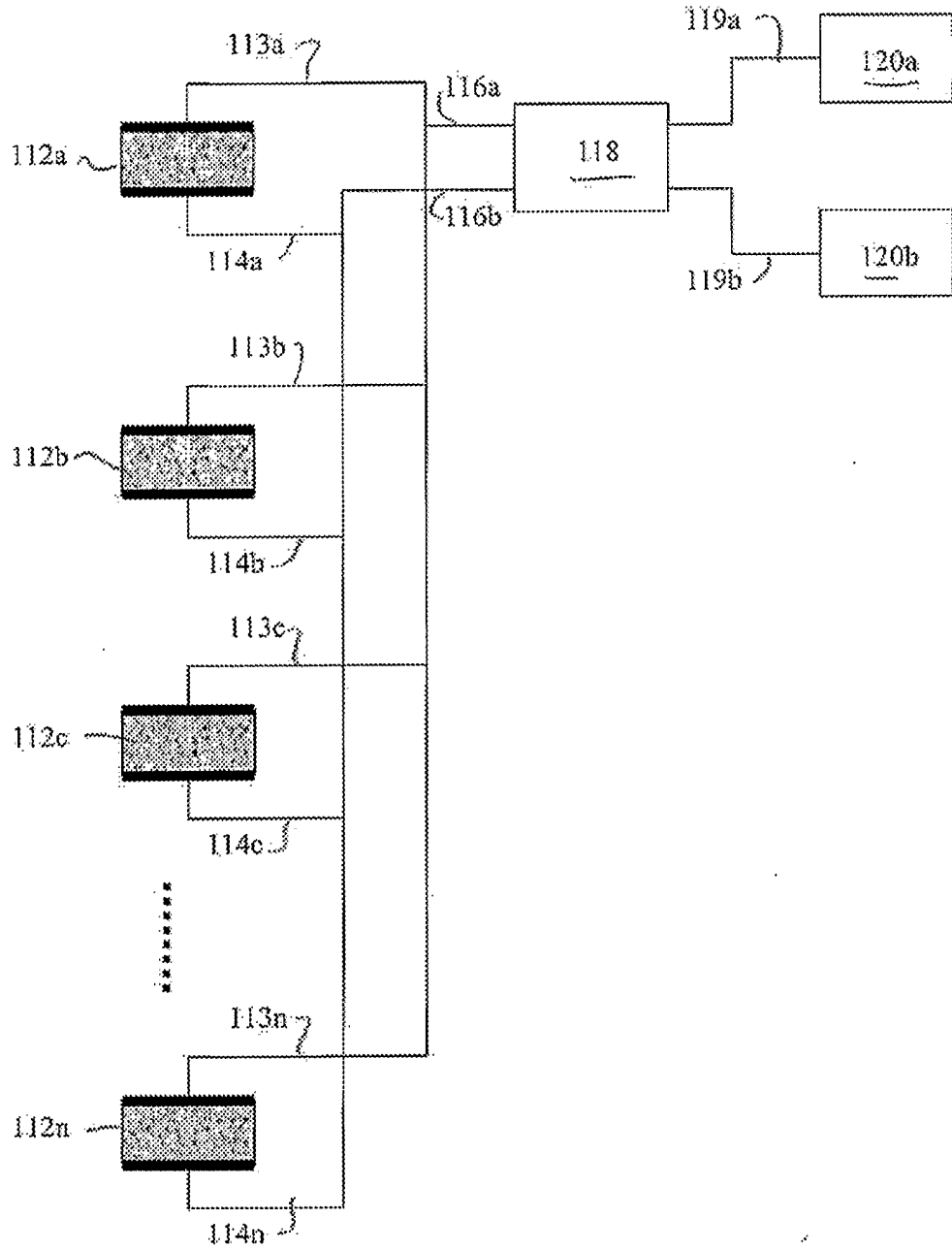

FIG. 10

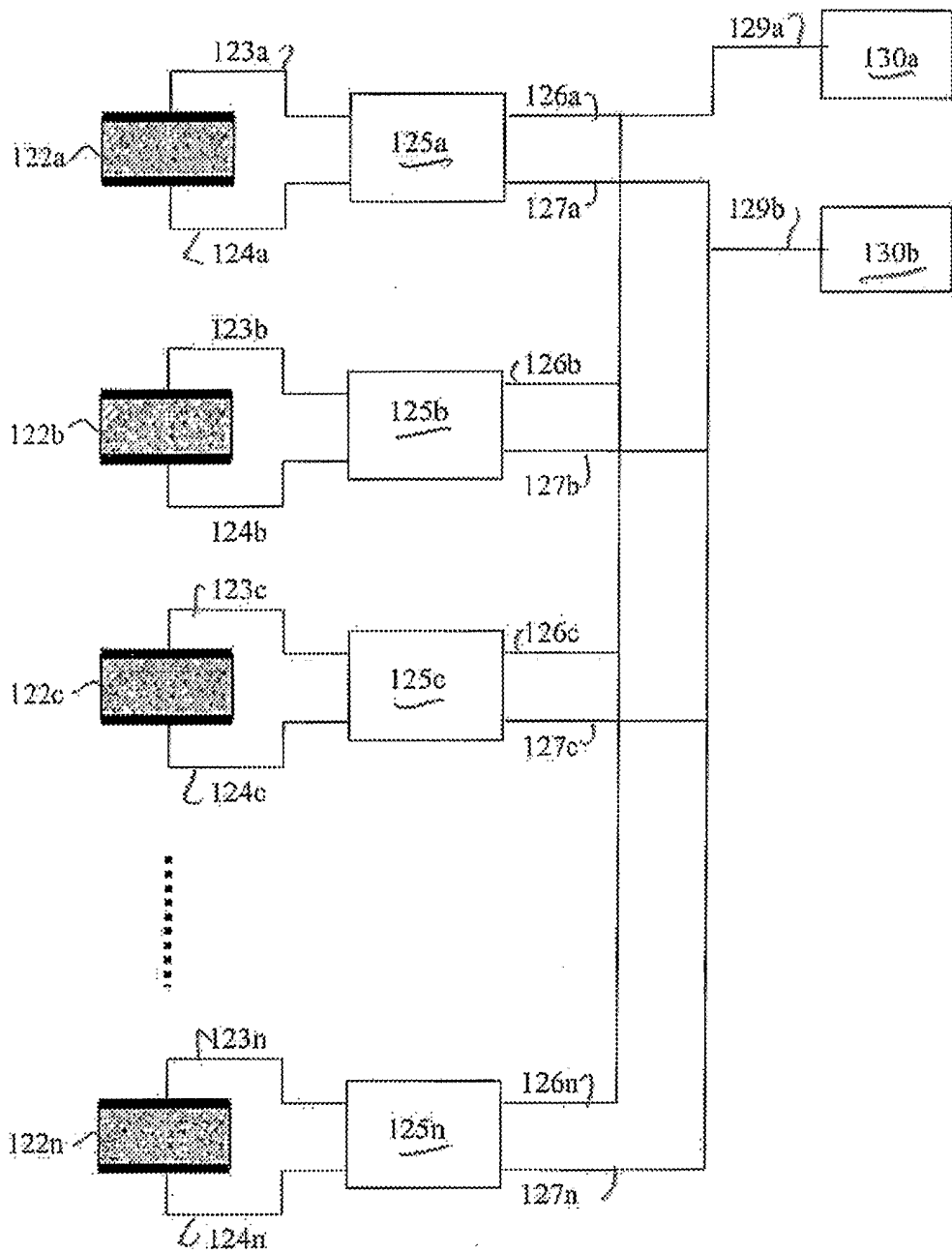

FIG. 11

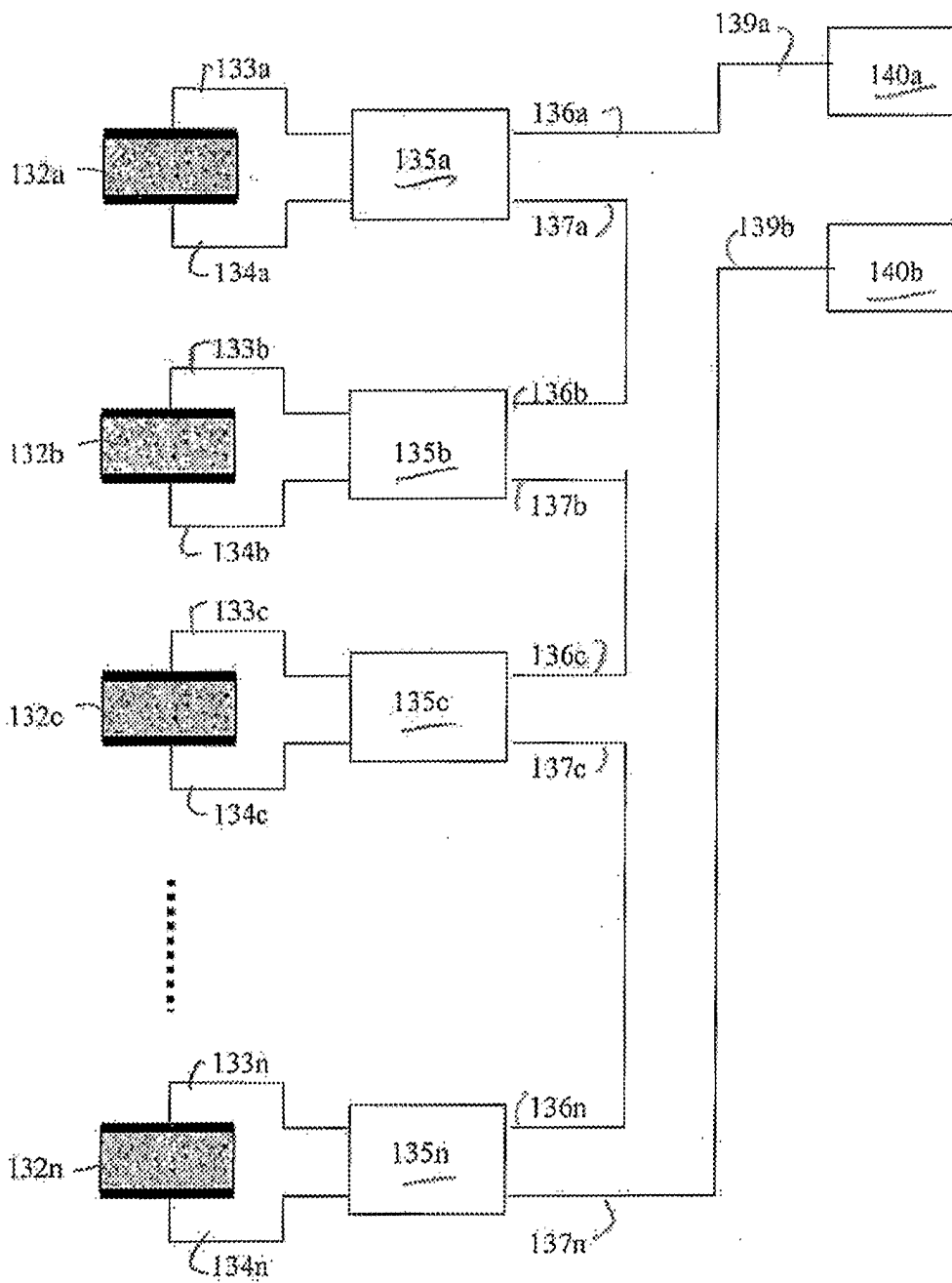

FIG. 12

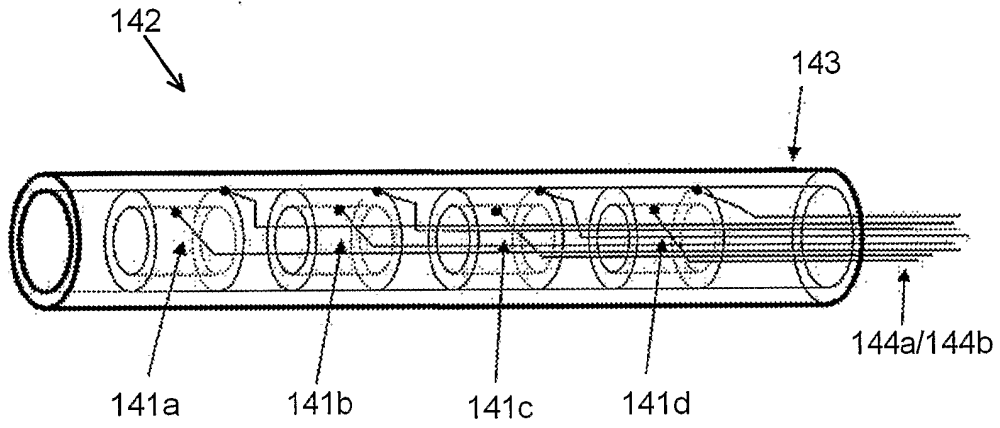

FIG. 13

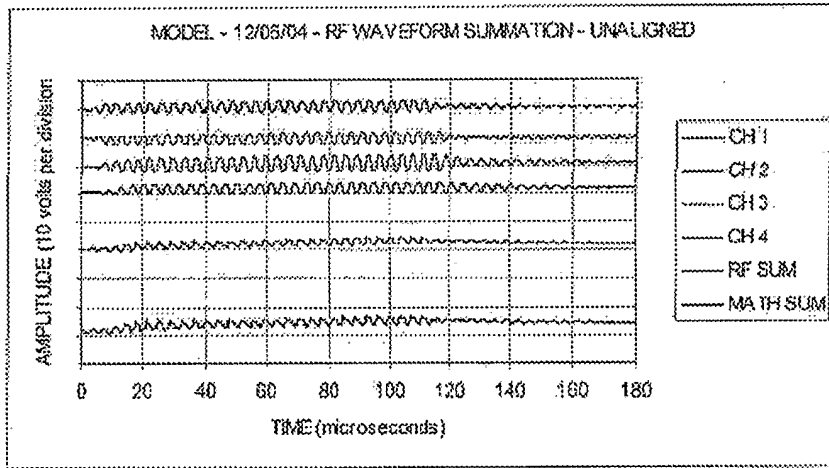

FIG. 14A

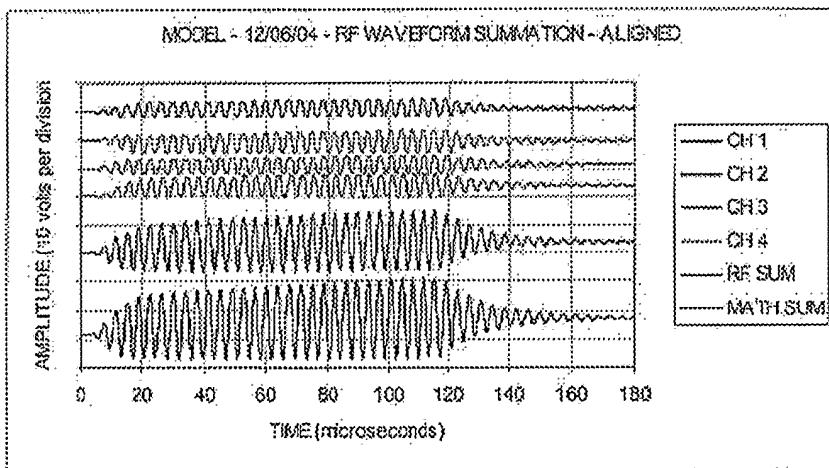

FIG. 14B

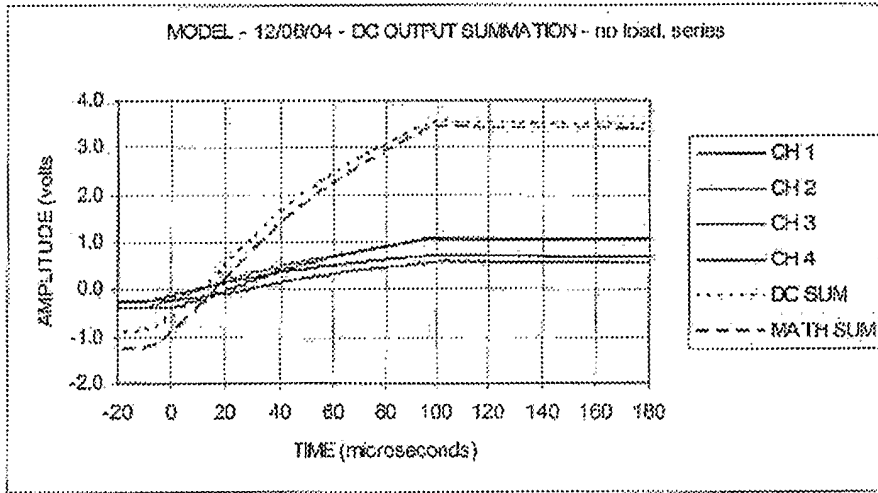

FIG. 14C

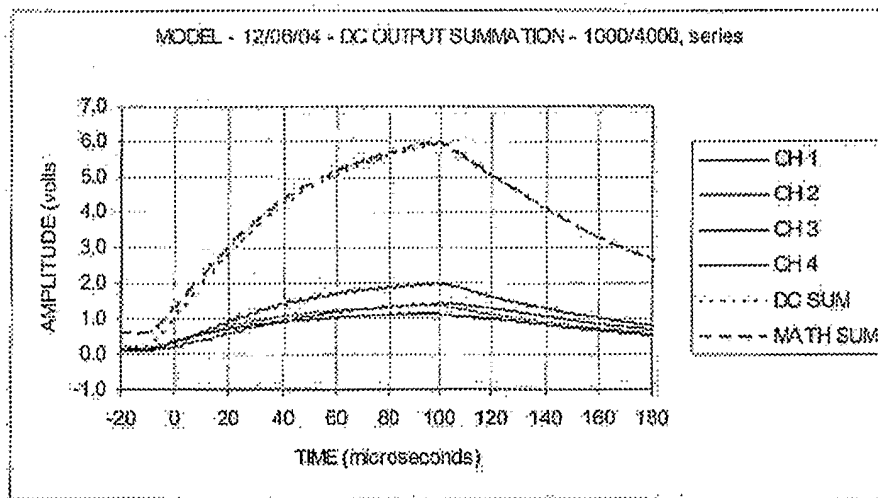

FIG. 14D

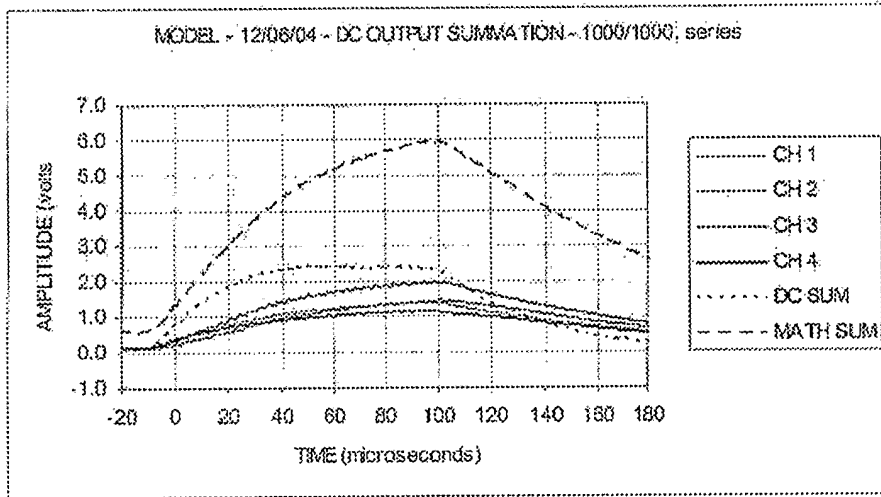

FIG. 14E

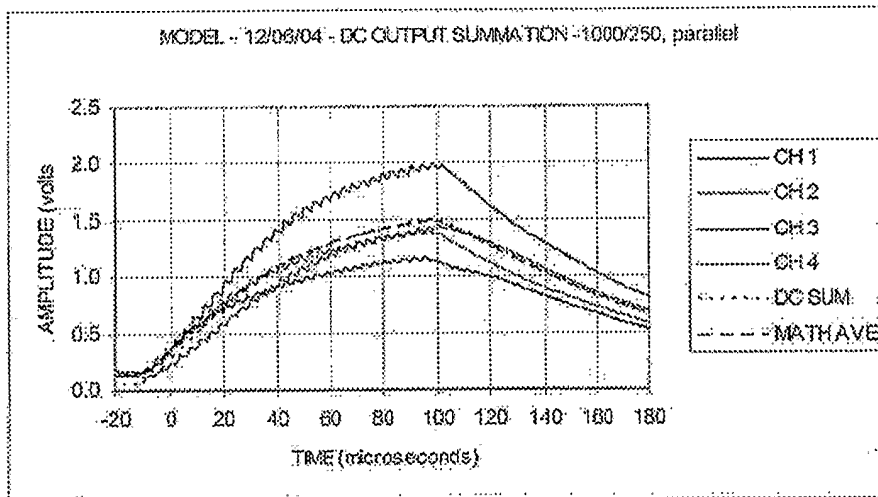

FIG. 14F

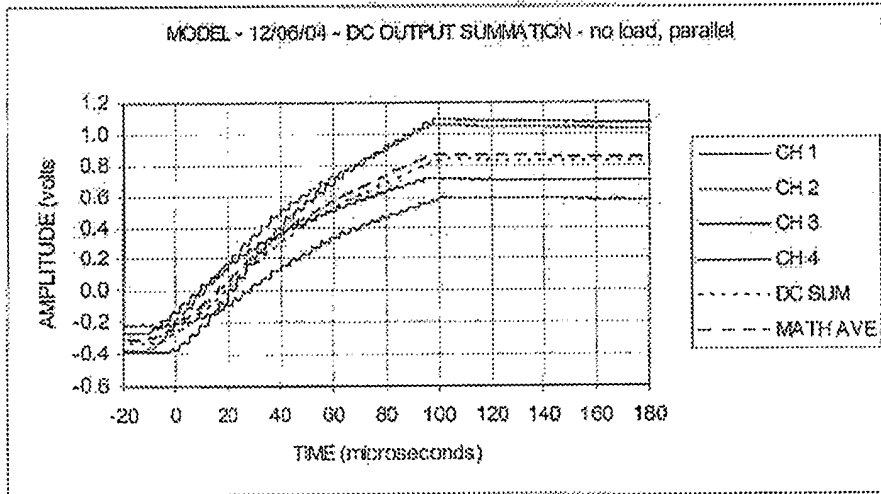

FIG. 14G

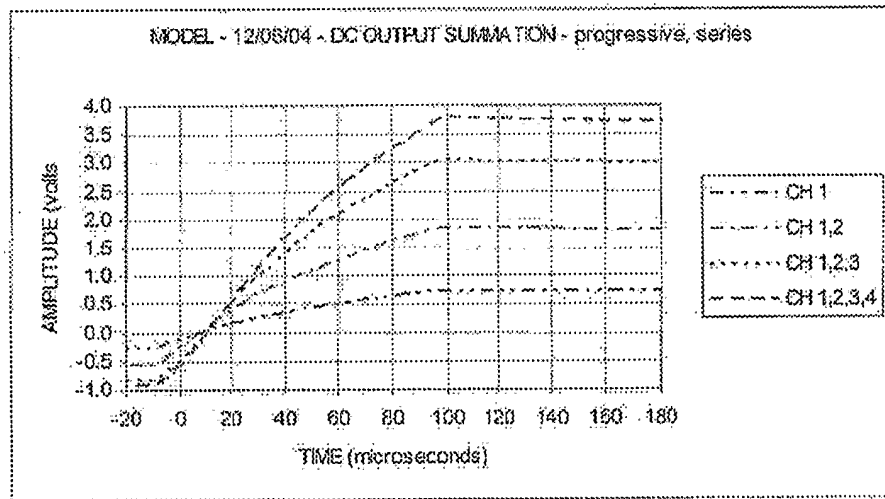

FIG. 14H

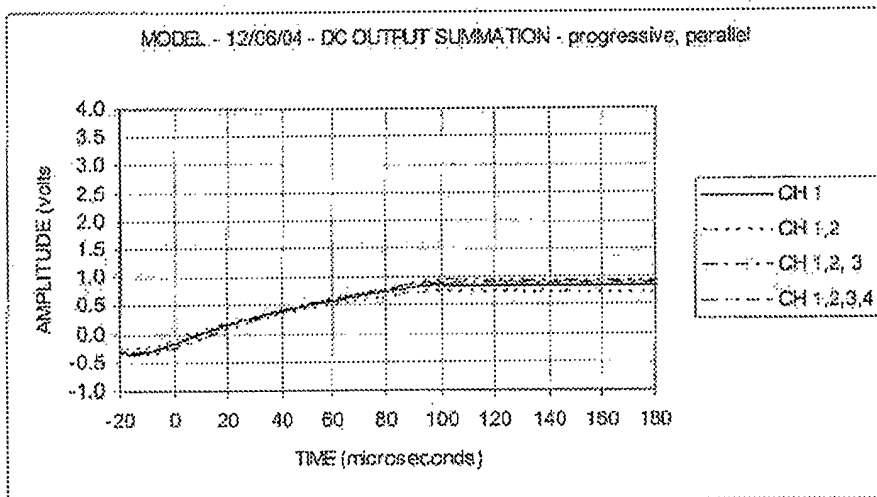

FIG. 14I

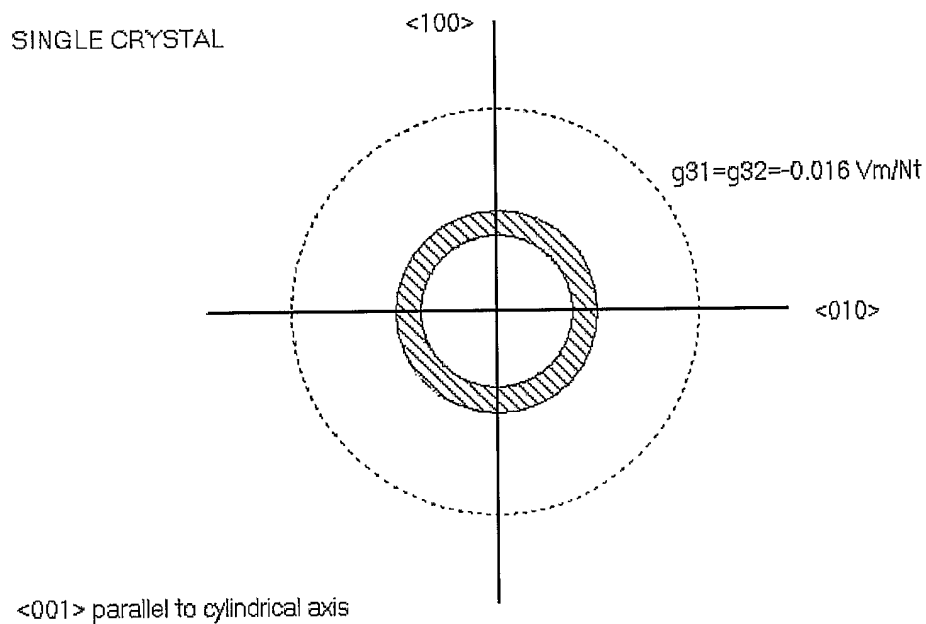

FIG. 15A

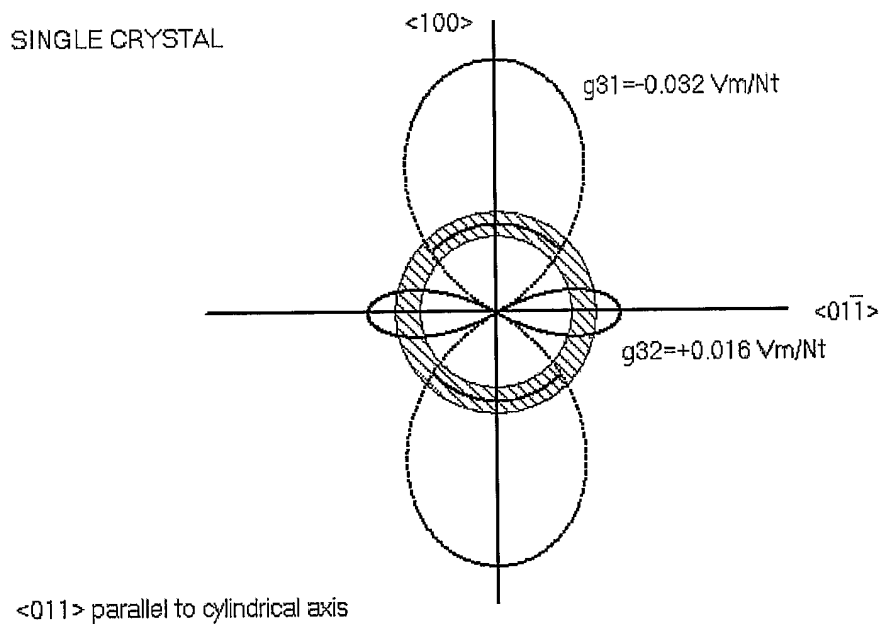

FIG. 15B

COMPOSITE SINGLE CRYSTAL
FOUR SECTIONS

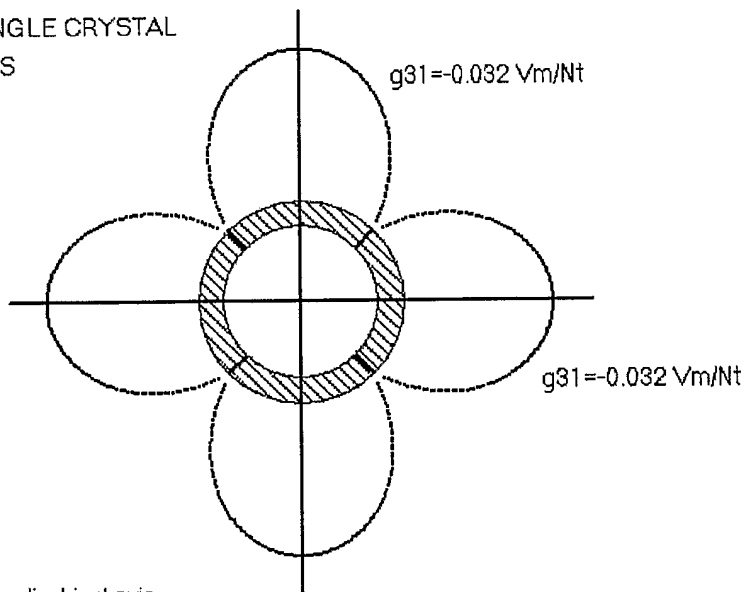

FIG. 15C

COMPOSITE SINGLE CRYSTAL
SIX SECTIONS

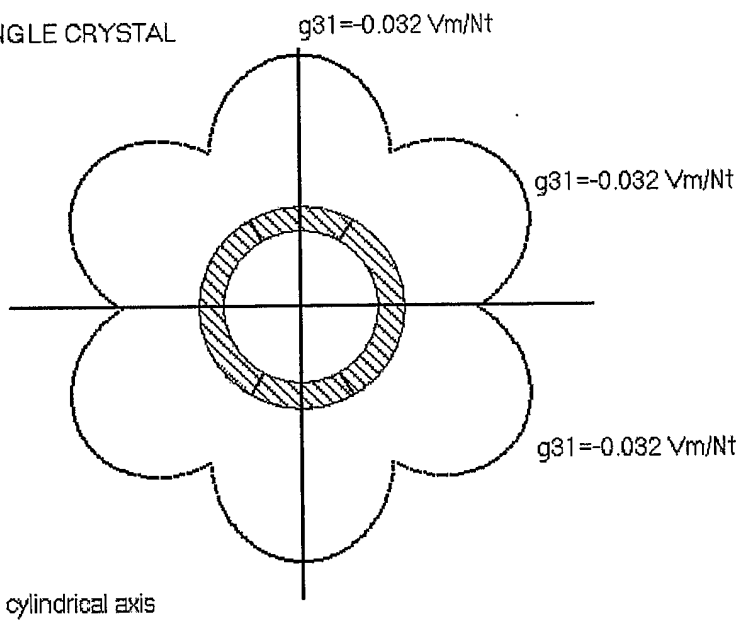

FIG. 15D