

No. 820,148.

PATENTED MAY 8, 1906.

J. SMITH.
LEATHER CUTTING MACHINE.
APPLICATION FILED OCT. 3, 1905.

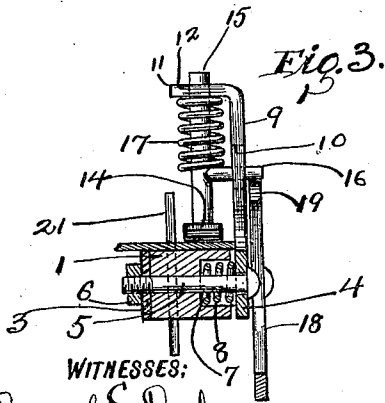
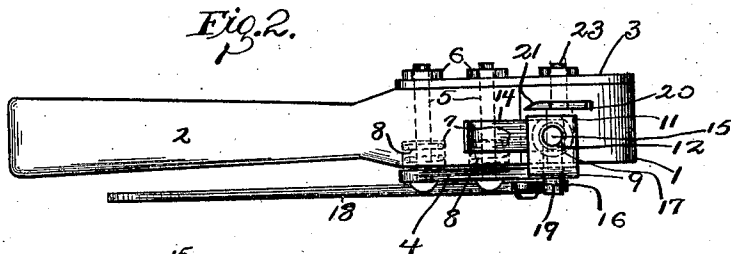
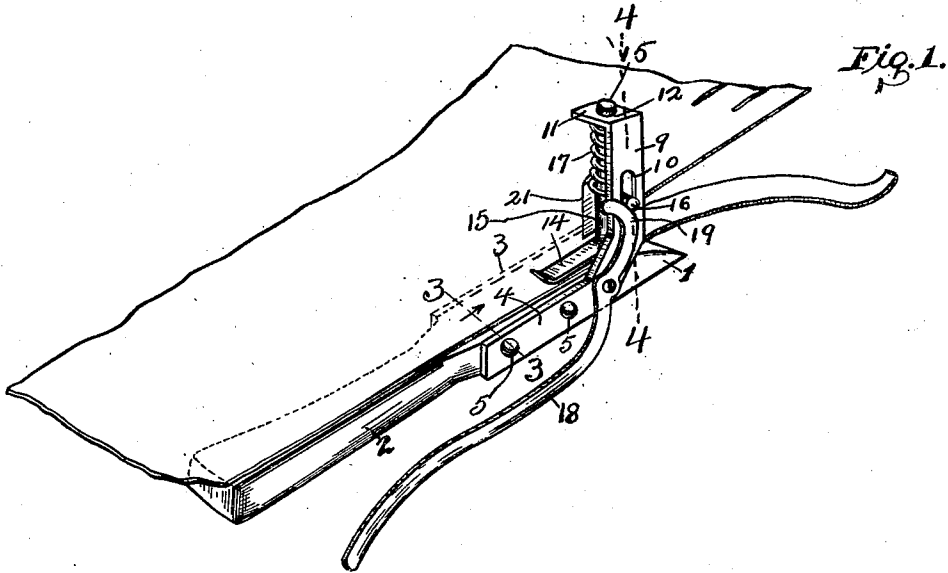

WITNESSES:
Daniel E. Daly.
Victor C. Lynch

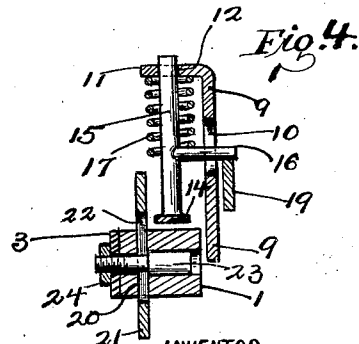

INVENTOR
J. Smith,
BY
Lynch & Dorer
ATTORNEYS.

UNITED STATES PATENT OFFICE.

JIMI SMITH, OF CLEVELAND, OHIO.

LEATHER-CUTTING MACHINE.

No. 820,148.

Specification of Letters Patent.

Patented May 8, 1906.

Application filed October 3, 1905. Serial No. 281,208.

To all whom it may concern:

Be it known that I, JIMI SMITH, a citizen of the United States of America, residing at Cleveland, in the county of Cuyahoga and State of Ohio, have invented certain new and useful Improvements in Leather-Cutting Machines; and I hereby declare the following to be a full, clear, and exact description of the invention, such as will enable others skilled in the art to which it pertains to make and use the same.

This invention relates to improvements in leather-cutting machines, and especially to machines for cutting leather into strips to make laces.

The object of this invention is to provide a machine of this character which will be of a convenient size, easily operated, and readily kept in repair.

My invention therefore consists in the features of construction and combination of parts, as described in the specification, pointed out in the claims, and illustrated in the accompanying drawings.

In the accompanying drawings, Figure 1 is a perspective view of my machine, showing a piece of leather being operated upon. Fig. 2 is a top plan of my machine without the leather. Fig. 3 is a section on line 3 3, Fig. 1. Fig. 4 is a section on line 4 4, Fig. 1.

Again referring to the drawings, 1 represents the body portion of the tool, which is preferably provided with a handle portion 2. Two plates 3 and 4, respectively, are secured at each side of the body portion 1 by means of bolts 5, which are provided with nuts 6. In pockets 7, which are formed around the bolts at one side of the body portion, are arranged coil-springs 8, the object of which is to normally hold the plate 4 away from the side of the body portion, so that when the nuts 6 are loosened on the ends of the bolts 5 the plate 4 will move away from the side of the body portion. To the plate 4 is secured an upright or standard 9, having a vertical slot 10, and at the upper end of said standard is formed an opening 12.

14 represents a presser-foot, which is provided with a stem 15, which extends up through the opening 12 in the flange 11. To the stem 15 is secured an arm 16, which extends through the vertical slot 10 in the standard 9 and projects beyond the outer surface of said standard. A coil-spring 17 is arranged on the stem 15 above the arm 16 and abuts against the under side of the flange

12, so as to normally hold the presser-foot against the upper surface of the body portion. To the side of the body portion is secured a lever 18, having a cam-shaped end portion 19, which is arranged to come in contact with the arm 16 in the stem 15 and lift said arm when the lever is operated.

In the body portion 1 is formed a vertical slot 20, arranged to receive a cutting-blade 21. In the cutting-blade 21 is formed a vertical slot 22, through which is passed a clamping screw or bolt 23, having a nut 24. By loosening the said bolt the blade can be moved up or down, and thereby bring a fresh portion of the cutting-blade in line with the leather which is being cut.

The operation of the machine is as follows: A number of cuts are made in the edge of the leather which is to be cut up into laces, and the cuts are spaced according to the width the laces are to be. The nuts 6 on the ends of the bolts 5 are then either loosened or tightened, so as to make the distance between the standard 9 and the cutting-blade the same as the width the laces are to be. The end of the lace which has been started by the cut in the edge of the leather is then inserted beneath the presser-foot, which has been raised by means of the lever, so that it projects sufficiently at the opposite side of the presser-foot to be grasped by the hand of the operator. The end of the lace and the sheet of leather are then held in one hand, and the machine is then held by the handle in the other hand and is slowly drawn toward the opposite end of the leather. The lace which is being cut from the leather passes between the cutting-blade and the standard 9, which serve both as guides and as a gage to preserve a uniform width in the lace.

What I claim is—

1. In a machine of the character indicated, a body portion, a handle secured to said body portion, a standard, a presser-foot mounted in said standard, a spring arranged to hold said presser-foot against the upper surface of said body portion, a cutting-blade arranged at the side of said presser-foot and means for adjusting said cutting-blade vertically so as to bring a new portion of the cutting-blade in contact with the material which is being cut.

2. In a machine of the character indicated, a body portion, bolts passing through said body portion, a plate supported by said bolts, springs arranged between said plate and the side of said body portion, a standard secured

to said plate, a presser-foot mounted in said standard, springs for holding said presser-foot against the surface of said body portion, means for lifting said presser-foot, a cutting-
5 blade arranged at the side of said presser-foot and means for adjusting said cutting-blade vertically.

3. In a machine of the character indicated, a body portion, a handle secured to said body
10 portion, a plate, bolts for securing said plate to said body portion, springs arranged between the plate and the side of said body portion, a standard arranged on said plate and provided with a vertical slot and a horizontal flange at
15 its upper end, a presser-foot, a stem secured to said presser-foot and arranged to extend

through the flange on said standard, an arm secured to said stem and extending through the slot in the standard, a spring arranged between said arm and said flange, and a lever
20 secured to the body portion and provided with a cam-shaped end arranged to engage with the arm on the presser-foot, substantially as described and for the purpose set
25 forth.

In testimony whereof I sign the foregoing specification in the presence of two witnesses.

JIMI SMITH.

Witnesses:

VICTOR C. LYNCH,
N. L. McDONNELL.